

PARTS LIST

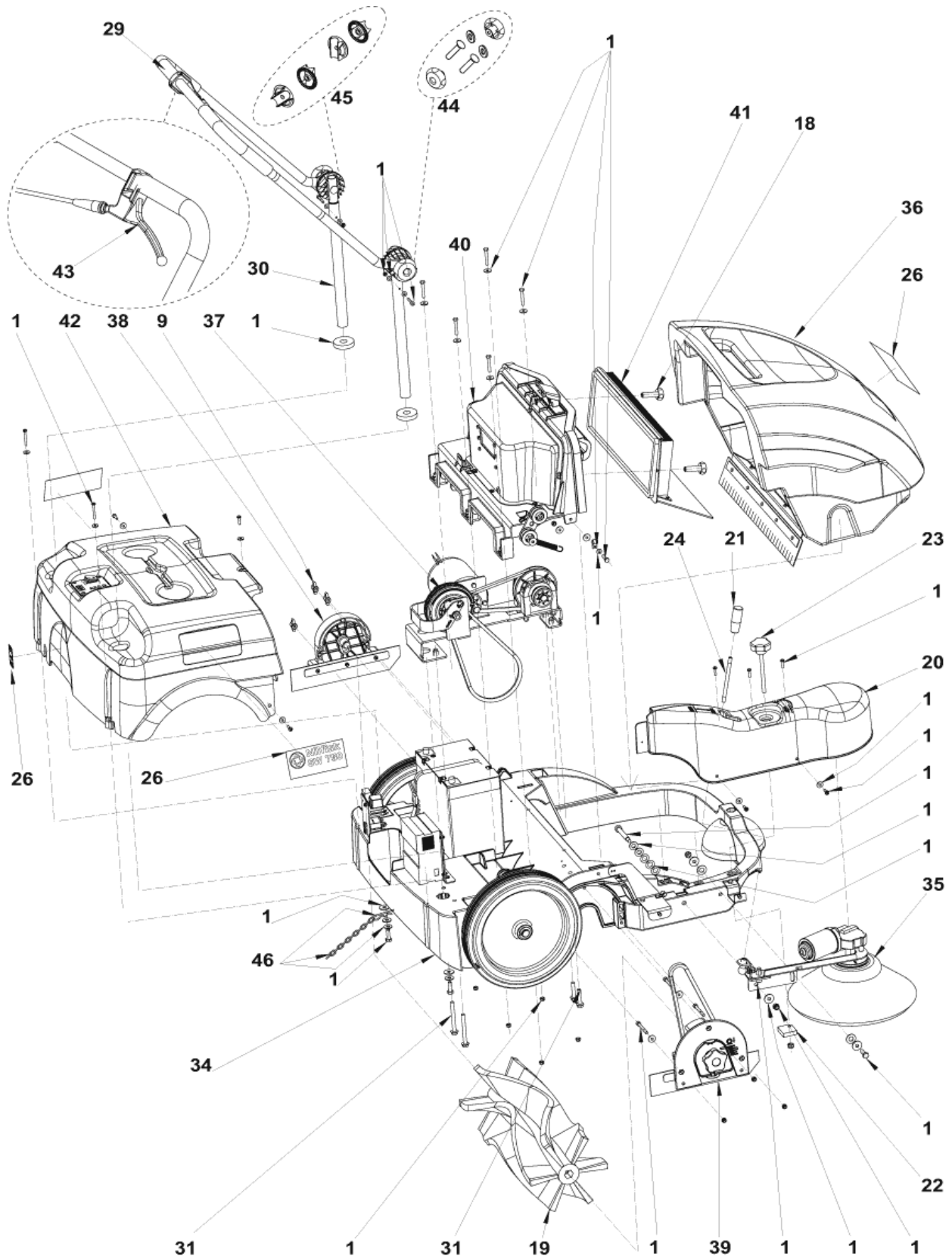

TABLE OF CONTENTS

General view	1
Chassis system	3
Side broom assembly	5
Hopper system	7
Transmission system	9
Left and right hatch assembly	11
Belt tensioner assemblies	13
Dust control system	15
Vacuum system	17
Control panel assembly	19
Wiring diagram	21



No.	Part No.	Qty.	Description	Part Note
1	1463858000	1	GENERAL HARDWARE KIT	
9	909 6356 000	1	KNOB WING M6 FEMALE 5 PCS SET	
18	146 2991 000	2	HANDWHEEL D.30 M6	
19	146 3016 000	1	BROOM MAIN 180X500 CHEVRON 6R NYLON	
19	1463174000	1	BROOM MAIN 200X500 CHEVRON 6R PPL 0.7	
20	1466781000	1	CRANKCASE SIDE BROOM GREY SIP	
21	146 3037 000	1	HANDLE LEVER	
22	146 3038 000	1	ADJUSTER BLOCK F. SIDE BROOM GALV.	
23	146 3039 000	1	KNOB M8X110	
24	146 3040 000	1	TIE-ROD F SIDE BROOM GALV.	
26	1463979000	1	DECALS SW750 KIT	
29	146 3066 000	1	HANDLE BAR MET.	
30	1466965000	1	BAR MET. F HANDLE 2 PCS SET	
31	1463868000	1	HARDWARE TRANSMISSION SYST KIT	
34		1	Chassis system	[1]
35		1	Side broom ass.	[2]
36		1	Hopper system	[3]
37		1	Transmission system	[4]
38		1	Left hatch ass.	[5]
39		1	Right hatch ass.	[5]
40		1	Dust control system	[6]
41		1	Filter ass.	[7]
42		1	Control panel ass.	[8]
43	146 3068 000	1	LEVER PLASTIC W/ CABLE	
44	1463859000	1	HANDLE FIXING KIT	
45	909 5099 000	1	RATCHET HANDLE ADJUST. 4 PCS SET	
46	1463260000	1	CHAIN GROUND KIT	
47	1463171000	1	CARPET KIT	[9]

Part Notes:

- [1] - Chassis system
- [2] - Side broom assembly
- [3] - Hopper system
- [4] - Transmission system
- [5] - Left and right hatch assembly
- [6] - Dust control system
- [7] - Vacuum system
- [8] - Control panel assembly
- [9] - NOT SHOWN - OPTIONAL

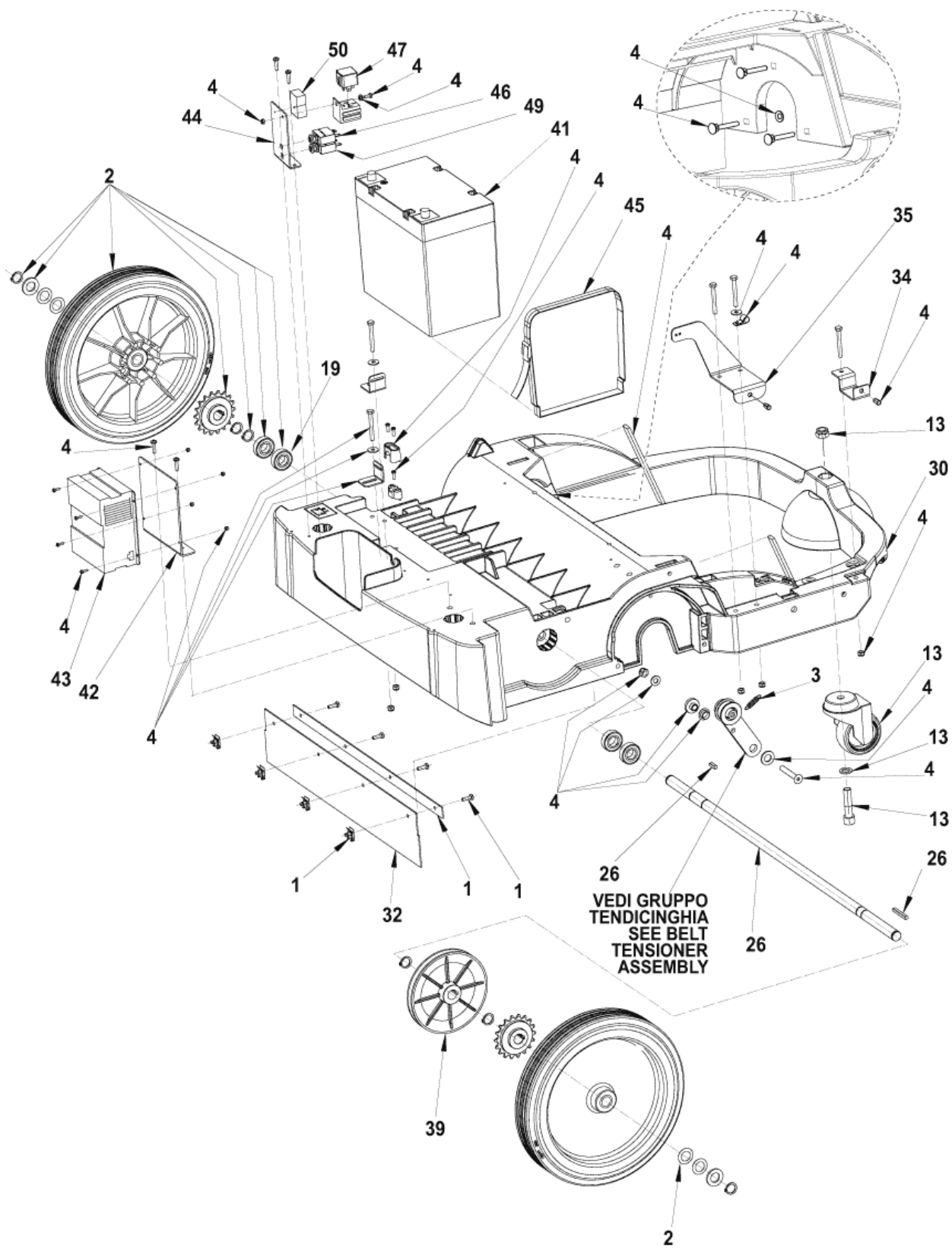

No.	Part No.	Qty.	Description	Part Note
1	146 3124 000	1	PLATES SKIRTS FIXING KIT	
2	1463860000	2	WHEEL D.300X50 GREY-BLACK KIT	
3	145 8925 000	1	SPRING EXTENSION D.E.8 WIRE D.0.8	
4	1463861000	1	HARDWARE CHASSIS SYSTEM KIT	
13	1463862000	1	WHEEL CASTOR D.75X32 GALV. KIT	
19	1467030000	4	BEARING BALL 6003 2RS SIP	
26	1463863000	1	SHAFT WHEELS KIT	
30	1466783000	1	CHASSIS SIP	
32	1463166000	1	SKIRTS KIT	
34	146 2983 000	1	BRACKET CARTER FIXING	
35	146 2984 000	1	BRACKET CARTER FIXING	
39	146 2998 000	1	PULLEY PLAST. SPZ DP.140	
41	1464483000	1	BATTERY 12V 49AH AGM MONOBLOC	[1]
41	1464853000	1	BATT.12V-87AH AGM MONOBLOC	[1]
42	146 3050 000	1	BRACKET BAT.CHARGER FIX	
43	146 3051 000	1	CHARGER BATT. ON BOARD 12V 6A 100-230V	
44	146 3053 000	1	SUPPORT ELECTRONIC COMP.	
45	1467834000	1	BELT BATTERY FIXING SIP	
46	146 3090 000	1	CIRCUIT BREAKER 5A	
47	146 3113 000	1	RELAY 12V 70A	
49	909 5706 000	1	CIRCUIT BREAKER 30A	
50	909 6341 000	1	HOLDER FUSE	
51	146 3052 000	1	HARNESS MACHINE	[2]
52	1463167000	1	SKIRTS NO MARKING KIT	[3]
53	9100000790	1	CABLE EXTENSION EU PLUG L.1000MM SIP	[2]
54	9096914000	1	CABLE EXTENSION US PLUG L.1500MM	[2]
55	1466318000	1	CABLE EXTENSION UK PLUG L.2000MM SIP	[2]
56	1467596000	1	FUSE BLADE 7.5A SIP	[2]
57	1463201000	1	BATTERY CLAMPS PLUS-MINUS KIT	[3]

Part Notes:

- [1] - OPTIONAL - SEE TSB IT 2010-058
 [2] - NOT SHOWN
 [3] - NOT SHOWN - OPTIONAL

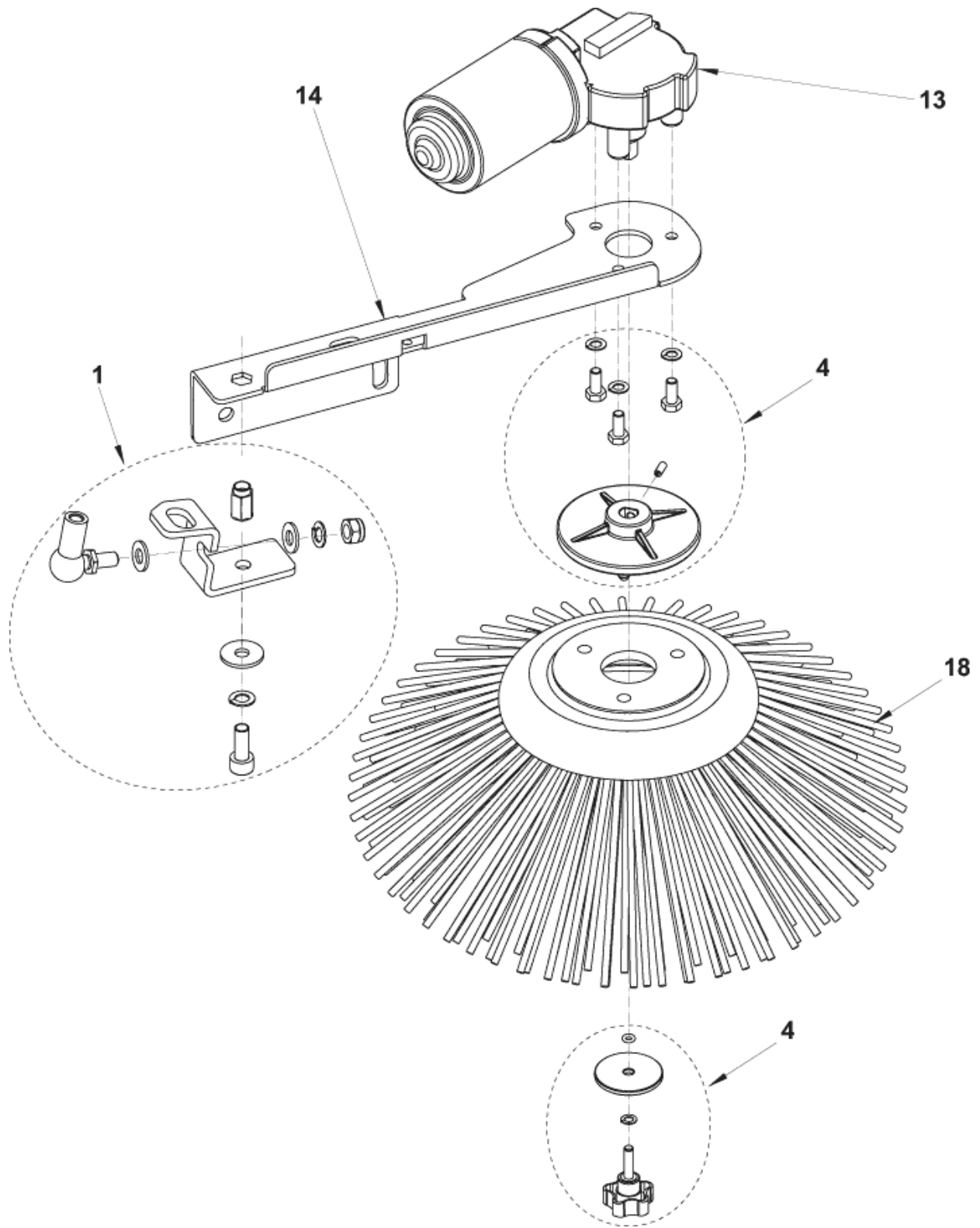

SIDE BROOM ASSEMBLY

SW 750

2017.11.01

2014.09.25

No.	Part No.	Qty.	Description	Part Note
1	1463864000	1	HARDWARE SIDE BROOM KIT	
4	1463865000	1	HUB SIDE BROOM FIXING KIT	
13	1465999000	1	REDUCTION GEARMOTOR 40W 12V SIP	
14	146 3029 000	1	SUPPORT SIDE BROOM MET. WHITE	
18	146 3035 000	1	BROOM SIDE 109X315 PPL 0.5	
18	146 3036 000	1	BROOM SIDE 145X300 NYLON	[1]

Part Notes:

[1] - ACCESSORY

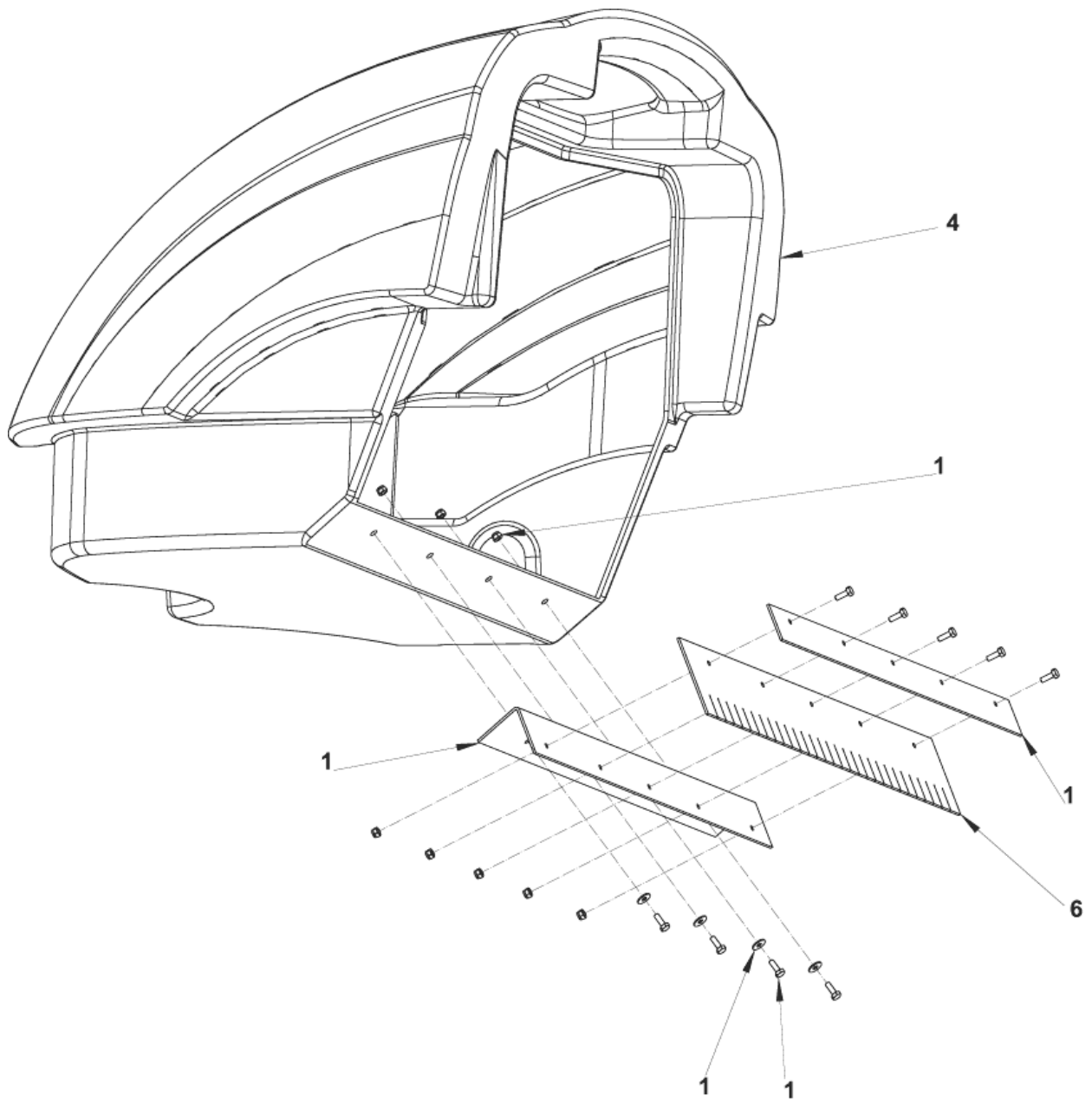

No.	Part No.	Qty.	Description	Part Note
1	146 3124 000	1	PLATES SKIRTS FIXING KIT	
4	1467768000	1	CONTAINER WASTE ROTOMOLDED GREY SIP	
6	1463166000	1	SKIRTS KIT	

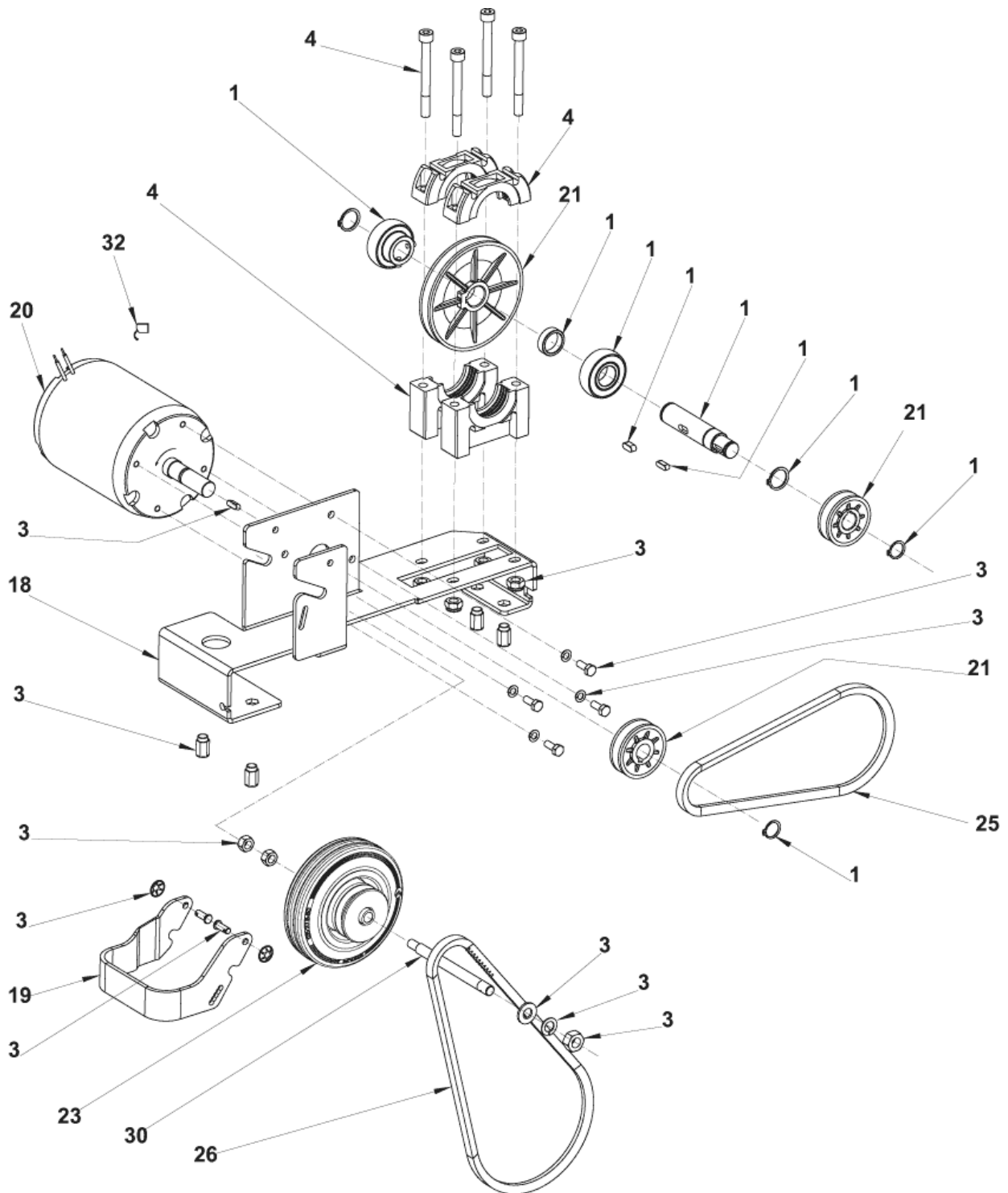

TRANSMISSION SYSTEM

SW 750

2017.11.01

2016.12.07

No.	Part No.	Qty.	Description	Part Note
1	1463867000	1	SHAFT PULLEYS KIT	
3	1463868000	1	HARDWARE TRANSMISSION SYST KIT	
4	1463866000	1	BEARING SUPPORTS KIT	
18	146 3000 000	1	PLATE MOTOR SUPPORT	
19	146 3002 000	1	BRACKET CLUTCH WHEEL	
20	1465998000	1	MOTOR ELECTRIC 200W 12V SIP	
21	1463869000	1	PULLEYS KIT	
23	1467647000	1	WHEEL DRIVE CLUTCH KIT	
25	1463305000	1	BELT V COGGED XPZ 587	
26	1464045000	1	BELT KIT	
30	146 3013 000	1	SHAFT DRIVE CLUTCH WHEEL	
32	909 6893 000	1	CARBON BRUSHES KIT 2+2 PCS	

ASSIEME PORTELLO SINISTRO - LEFT HATCH ASSEMBLY

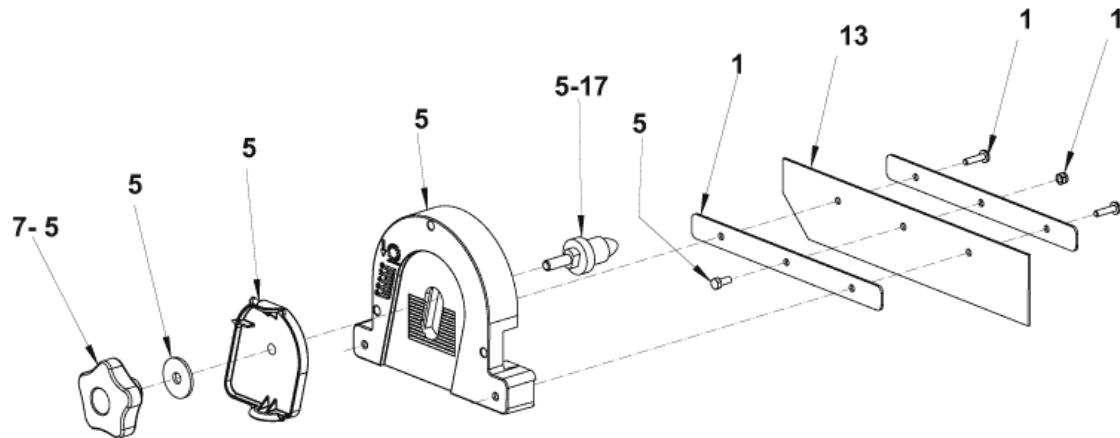

ASSIEME PORTELLO DESTRO - RIGHT HATCH ASSEMBLY

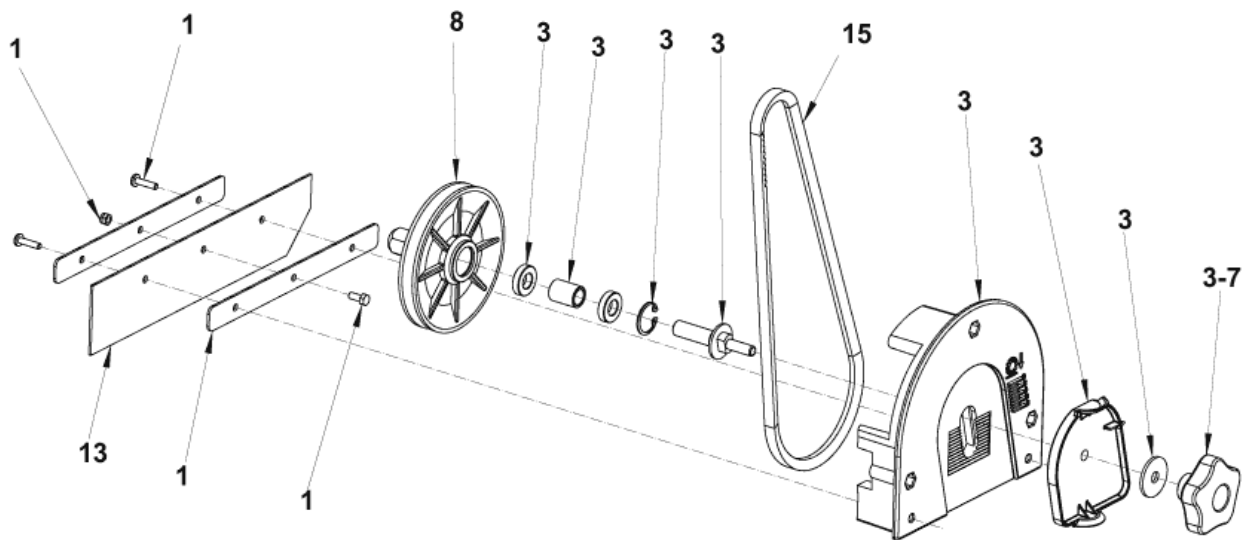

LEFT AND RIGHT HATCH ASSEMBLY

SW 750

2017.11.01

2016.12.07

No.	Part No.	Qty.	Description	Part Note
1	146 3124 000	1	PLATES SKIRTS FIXING KIT	
3	1463870000	1	HATCH RIGHT FIXING KIT	
5	1463871000	1	HATCH LEFT FIXING KIT	
7	146 1852 000	2	KNOB M8	
8	146 3014 000	1	PULLEY PLAST. SPZ DP. 112	
13	1463166000	1	SKIRTS KIT	
15	146 3027 000	1	BELT V COGGED XPZ 787	
17	146 3020 000	1	PIN MAIN BROOM PHOS.	

GRUPPO TENDICINGHIA DOPPIO - DOUBLE BELT TENSIONER ASSEMBLY

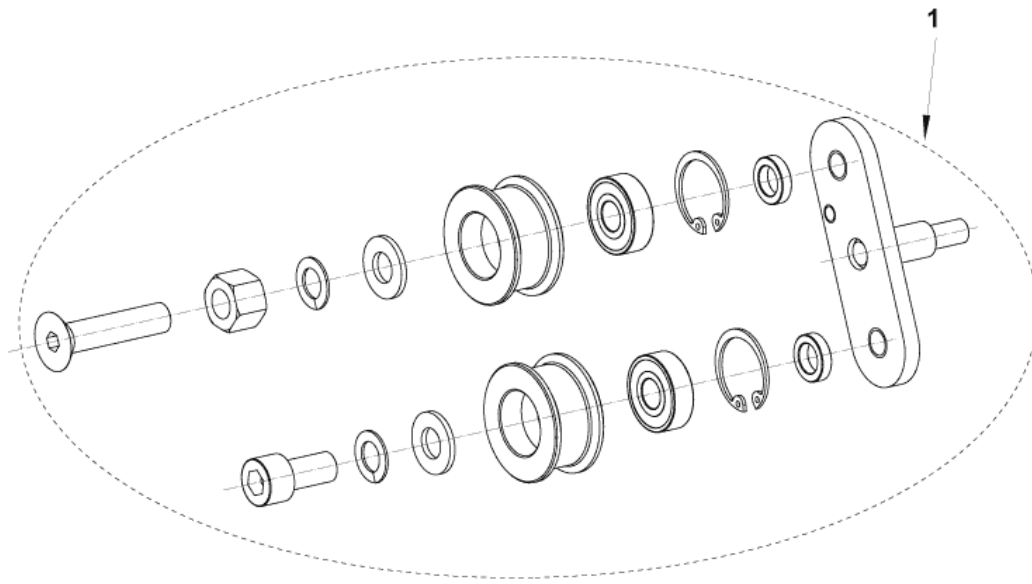

GRUPPO TENDICINGHIA - BELT TENSIONER ASSEMBLY

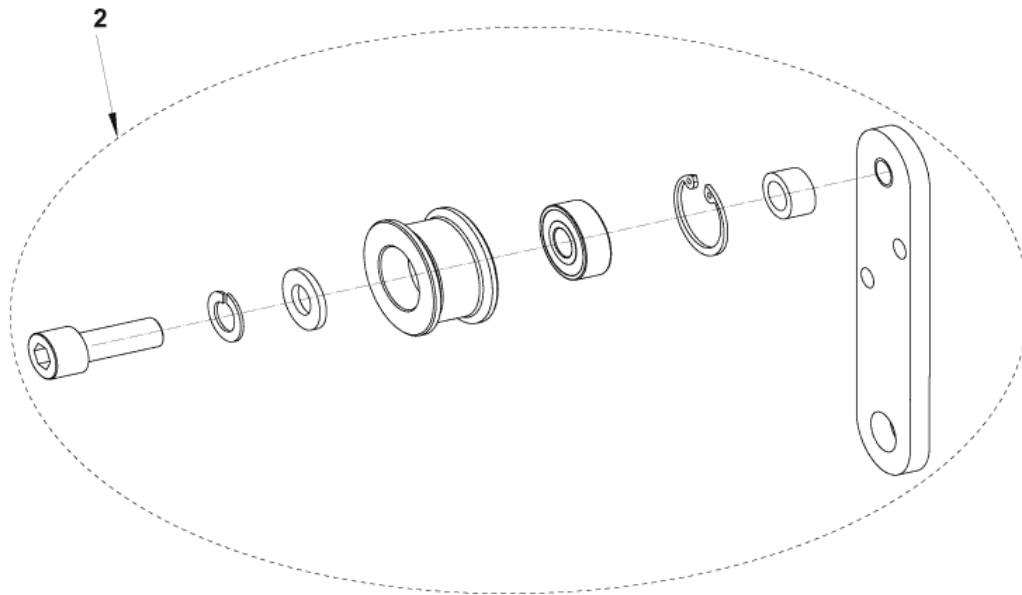

BELT TENSIONER ASSEMBLIES

SW 750

2017.11.01

2016.12.07

No.	Part No.	Qty.	Description	Part Note
1	1463872000	1	BELT TENSIONER DOUBLE KIT	
2	1463873000	1	BELT TENSIONER KIT	

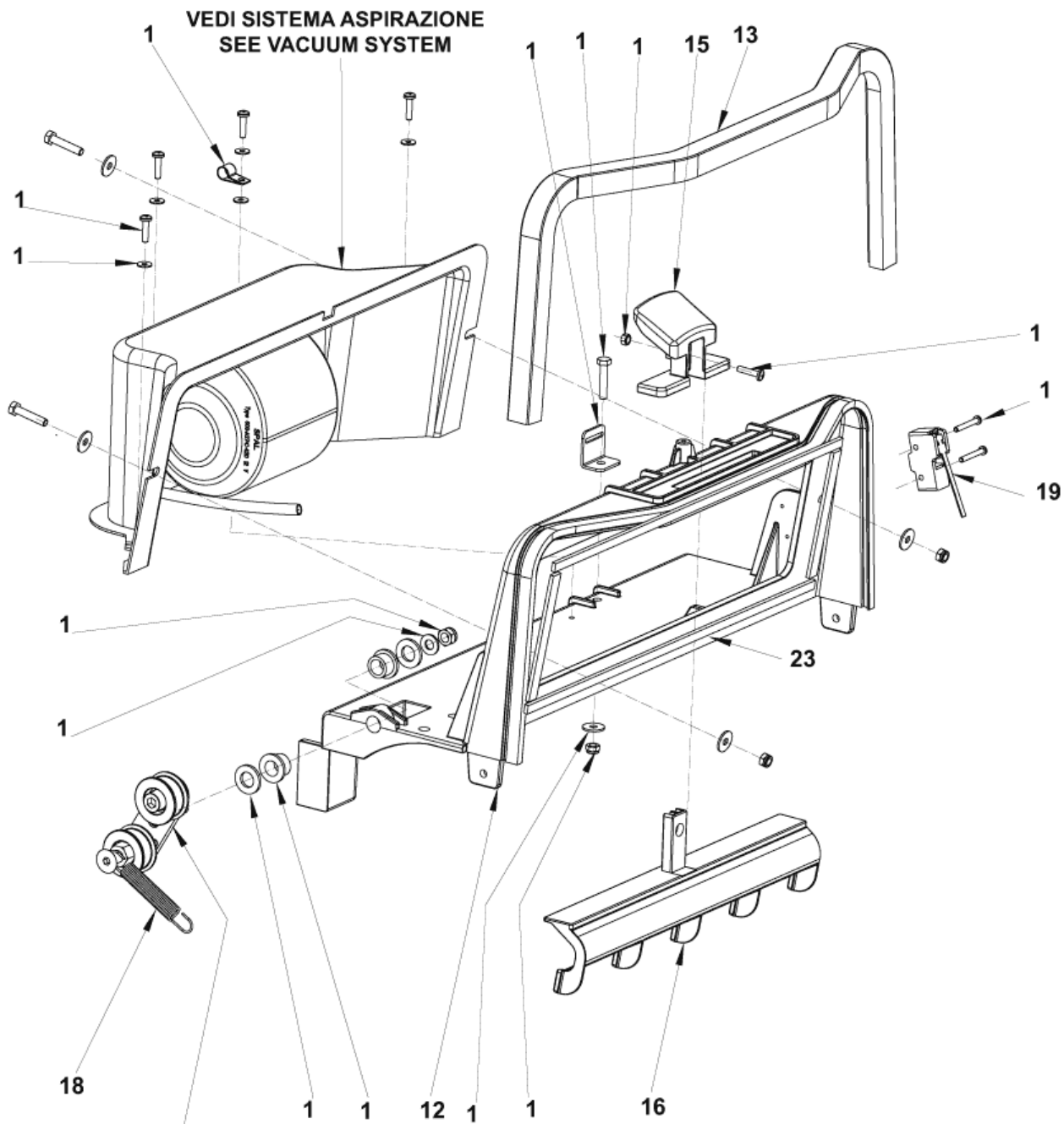

DUST CONTROL SYSTEM

SW 750

2017.11.01

2016.12.07

No.	Part No.	Qty.	Description	Part Note
1	1463874000	1	HARDWARE DUST CONTROL SYST.KIT	
12	146 2988 000	1	SUPPORT FILTER	
13	1463747000	1	GASKET EXTRUDED L.845MM	
15	146 2992 000	1	HANDLE FILTER SHAKER PLAST.	
16	146 2993 000	1	FILTER SHAKER PLAST.	
18	145 0274 000	1	SPRING EXTENSION D.E.12 WIRE D.1.5	
19	1466506000	1	MICROSWITCH 10A 250V SIP	
23	1463176000	2	GASKET ADHESIVE FOR FILTER KIT	

ASSIEME ASPIRAZIONE - VACUUM SYSTEM

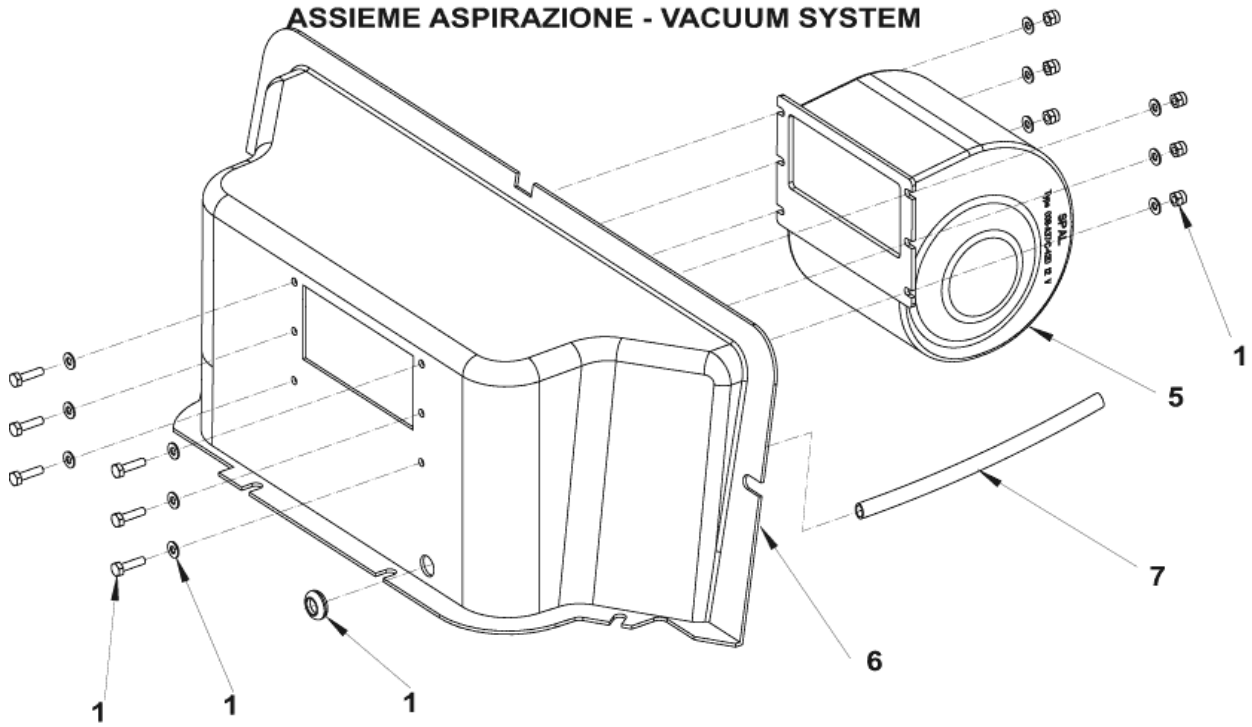

GRUPPO FILTRO - FILTER ASSEMBLY

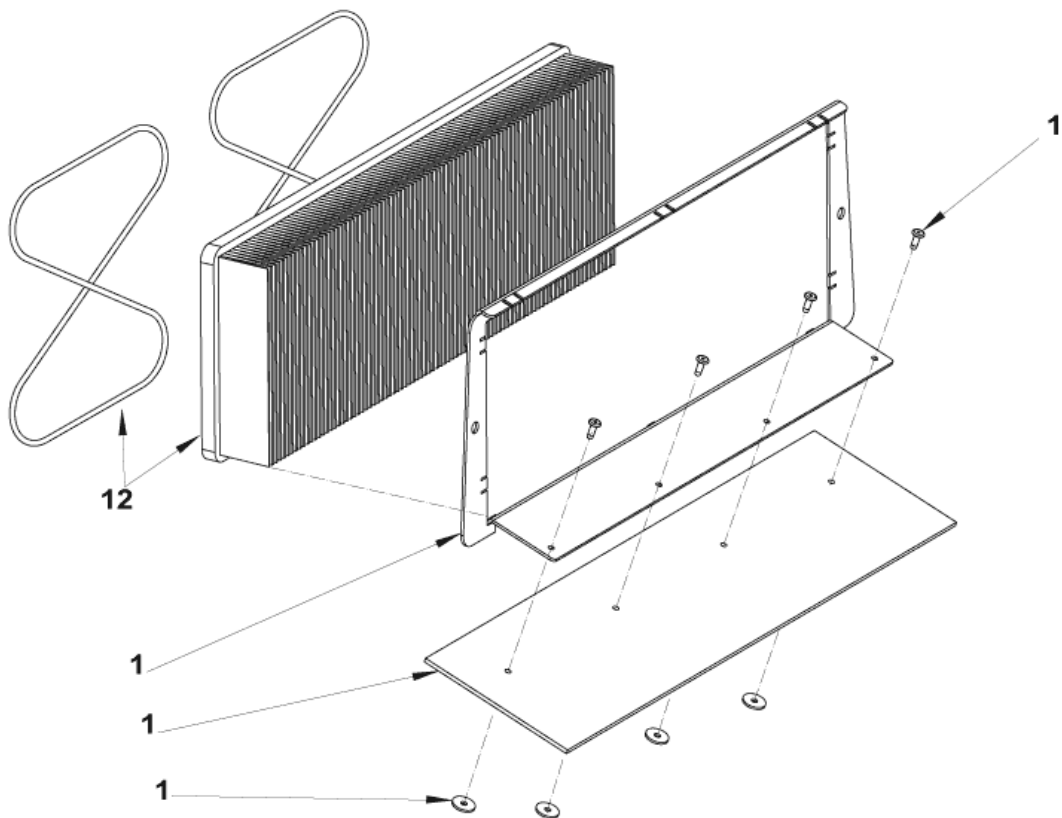

No.	Part No.	Qty.	Description	Part Note
1	1463875000	1	HARDWARE FILTER FIXING KIT	
5	146 1804 000	1	BLOWER CENTRIFUGAL 12V	
6	146 3055 000	1	CONVEYOR	
7	146 3125 000	1	SHEATH D.6XD.7 L 200	
12	1463161000	1	FILTER POLYESTER KIT	

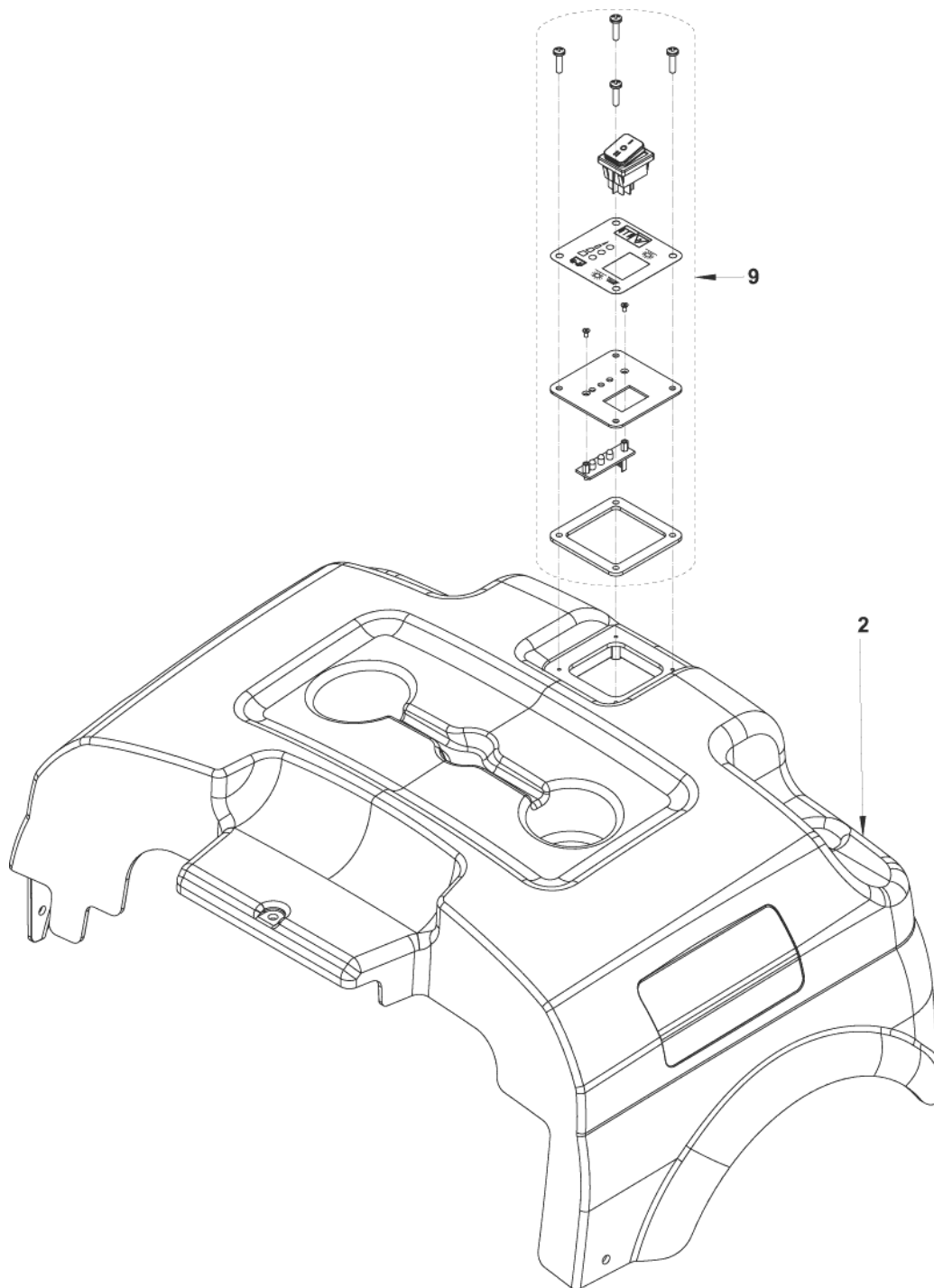

CONTROL PANEL ASSEMBLY

SW 750

2017.11.01

2016.12.07

No.	Part No.	Qty.	Description	Part Note
2	1466779000	1	COVER REAR GREY SIP	
9	146 3123 000	1	PANEL CONTROL W/DECAL KIT	

WIRING DIAGRAM

SW 750

146 3089 000 - Rev.B

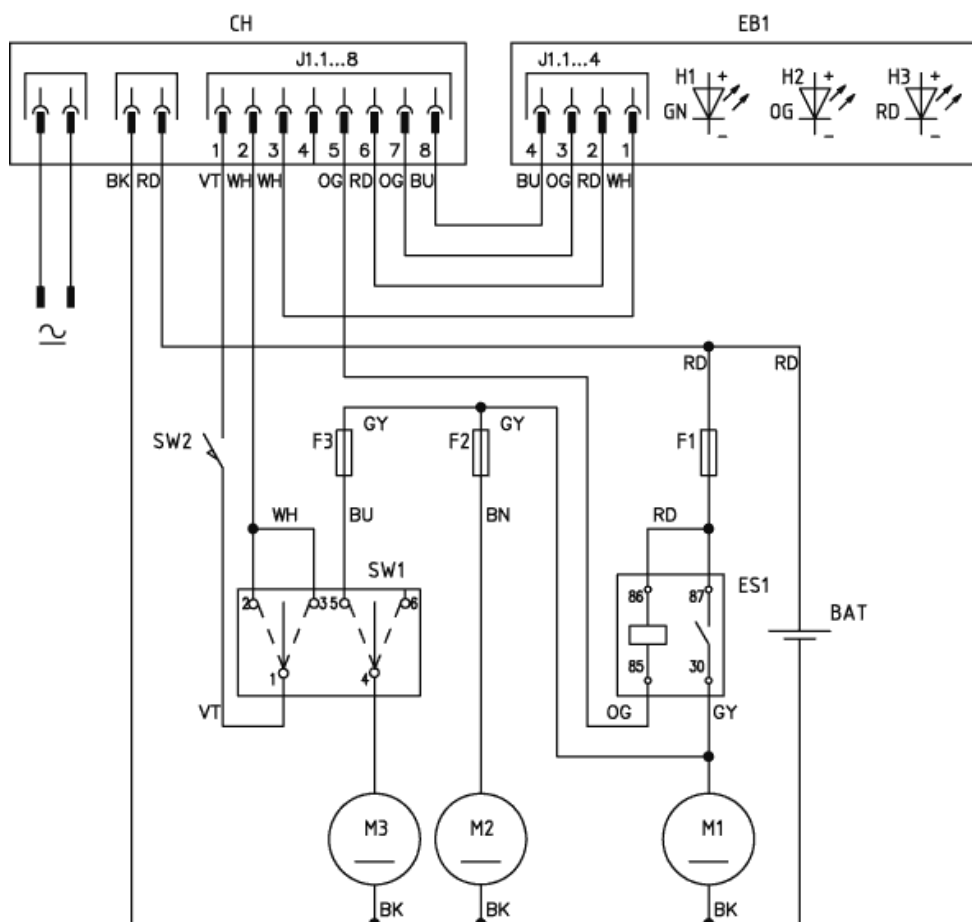

COMPONENTI		COMPONENTS
BAT	Batteria 12V	12V Battery
CH1	Caricabatterie-controllo funzioni	Batt. charger / Function controller
EB1	Scheda LED	LED board
ES1	Relé	Relais
F1	Fusibile principale	Main circuit breaker
F2	Fusibile ventola	Fan fuse
F3	Fusibile spazzola laterale	Side brush circuit breaker
H1	Led batteria piena carica	Full charge led
H2	Led batteria mezza carica	Half charge led
H3	Led batteria scarica	Empty charge led
M1	Motore principale	Main motor
M2	Ventola aspirazione	Fan
M3	Motore spazzola laterale	Side brush motor
SW1	Interruttore	Switch
SW2	Microinterruttore cofano	Hopper microswitch

No.	Part No.	Qty.	Description
-----	----------	------	-------------

