

ATTIX 33/44 L + M + H

VHS 40/42 L + M + H

Service manual



ENGLISH VER. 4



Blue line models:

ATTIX 33-01 IC
 ATTIX 33-2L PC / IC - ATTIX 33-21 PC / IC
 ATTIX 44-2L PC / IC - ATTIX 44-21 PC / IC
 ATTIX 33-2M PC / IC - ATTIX 33-2H PC / IC
 ATTIX 44-2M PC / IC - ATTIX 44-2H PC / IC

Grey line models:

VHS 40 L30 PC / IC
 VHS 40 L30 LC FM IC
 VHS 40 L40 LC FM IC
 VHS 42 L30 MC PC / IC
 VHS 42 L30 HC PC / IC
 VHS 42 L40 MC PC / IC
 VHS 42 L40 HC PC / IC

A. Safety issues 4

B. Technical data 5

C. Construction / function 9

D. Troubleshooting 14

E. Service / repair 16

F. Spare parts 35

G. Electrical diagrammes 41

H. Tools 50

In this manual you will find the essentials you need to know when repairing wet and dry cleaners of the ATTIX and VHS series.

When carrying out repairs, make sure you have a suitable workbench or the like with the necessary power supply available.

If you determine an error in operation, be sure to refer the customer to the user manual.

A fault in the equipment can have a number of causes. Chapter D Troubleshooting will help you here.

Use the illustrated spare parts lists for your repairs. These show you the location of the individual parts and the sequence in which they are assembled.

Read the technical information sheets. These will tell you about any technical modifications made after publication of this repair manual.

Technical information sheets are a supplement to the spare parts list until a follow-on publication.

Repair manuals and technical information sheets should be available at the site where repairs are carried out. Further repair manuals of the ATTIX and VHS series may be necessary for repairs to the equipment.

It is not permitted to give the repair manuals to third parties.

Use original Nilfisk spare parts only!

Symbols used to mark instructions



Safety instructions marked with this symbol in this manual must be observed to prevent danger to persons.

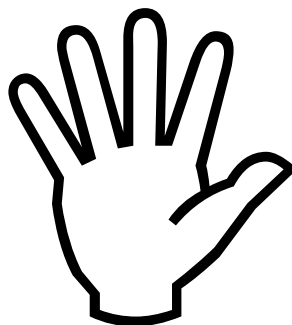

This symbol is used to mark safety instructions that must be observed to prevent damage to the equipment and degradation of performance.



This symbol indicates tips and instructions to simplify work and to ensure safe operation.

For your own safety.



Repairs should only be made by someone who has received proper instructions for the job or who is a qualified electrician

WARNING:
The upper section of the machine contains live components. Contact with live components leads to serious or even fatal injuries. Always disconnect the mains plug before disassembly.

Observe national safety directives and regulations for the electrical engineering trade, in particular:

IEC 60335-2-69
 EN 60335-2-69

DIN VDE 105 part 1:
 operation of electrical power installations.

DIN VDE 0701/0702:
 repair, modification and testing of electrical installations.

Before starting the equipment, be sure to read the accompanying user manual, and keep it close as reference.

The equipment should only be used by persons who have been instructed in its use and are authorized to do so.

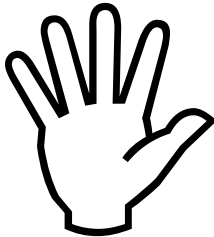

ESD (electrostatic discharge)

Observe the following ESD precautions before any repair of or near electronic parts:

- Touch the protective conductor to discharge your own body.
- Possibly wear an anti-static wrist strap.
- Use a conducting floor or tabletop.
- Never touch a circuit board or electronic components - always hold them by the plastic or insulation.
- Transport electronic parts in conductive packaging (e.g. special ESD packages).

ATTIX 33/44 Standard and L-class machines

ATTIX 33, ATTIX 44												
	EU, FR		DK/CH/AU/NZ		GB 230V		GB 110V		US		JP	
	33-01 IC PC 33-2L IC	44-2L PC 44-2L IC	33-01 IC PC 33-2L IC	44-2L PC 44-2L IC	33-01 IC PC 33-2L IC	44-2L PC 44-2L IC	33-2L PC 33-2L IC	44-2L PC 44-2L IC	33-01 IC PC 33-21 IC 44-21 IC	110- 120 120	110- 120 120	33-01 IC 44-21 PC 44-21 IC
Possible voltage	220- 240	220- 240	220- 240	220- 240	220- 240	220- 240	110-120	110-120	110- 120 120	110- 120 120	100	
Power P _{IEC}	1200	1200	1200	1200	1200	1200	1000	1000	1000 1,34	890/7, 4A 1,2 1,2	1200	
Connected load for ap- pliance socket	-	2400	-	1100	-	1700	750 1750	750 1750	-	550/4, 6A	-	
Mains frequency	50/60	50/60	50/60	50/60	50/60	50/60	50/60	50/60	50/60	50/60	50/60	50/60
Fuse	A 16	16	10	10	10	13	16	16	15	15	15	15
Protection grade (moist, dust)	IPX4											
Protection class (electrical)	I											
Max. Airflow*	l/s	75							71			71
	m ³ /h	270							252			252
	CFM	159							150			150
Max. Vacuum	kPa	25							23			25
	hPa	250							230			250
	in	100							92			100
Sound pressure level	69 ± 2											
Working sound level	60 ± 2											
Vibration ISO 5349 a _h	≤ 2,5											
Weight	kg	14,5	14,5	14,5	14,5	16	14,5	16	14,5	14,5	16	14,5
	lb	31,9	31,9	31,9	31,9	35,3	31,9	35,3	31,9	31,9	35,3	31,9
Filter surface area	m ²	0,5										
Dust class	-	L	L	L	L	L	L	L	L	L	L	-

* measured at turbine
Specifications and details are subject to change without pri-
or notice.

ATTIX 33/44 M & H-class machines

		ATTIX 33 M/H, ATTIX 44 M/H																	
		EU, FR				DK/CH/AU/NZ				GB 230V				GB 110V					
		33-2M PC 33-2M IC	44-2M PC 44-2M IC	33-2H PC 33-2H IC	44-2H PC 44-2H IC	33-2M PC 33-2M IC	44-2M PC 44-2M IC	33-2H PC 33-2H IC	44-2H PC 44-2H IC	33-2M PC 33-2M IC	44-2M PC 44-2M IC	33-2M PC 33-2M IC	44-2M PC 44-2M IC	33-2M PC 33-2M IC	44-2M PC 44-2M IC				
Possible voltage	V	220-240	220-240	220-240	220-240	220-240	220-240	220-240	220-240	220-240	220-240	220-240	220-240	110-120	110-120				
Power P _{IEC}	W	1200	1200	1195	1195	1200	1200	1195	1195	1200	1200	1200	1200	1000	1000				
Connected load for appliance socket	W	2400	2400	2400	2400	1100	1100	1100	1100	1100	1700	1700	1700	750	1750				
Mains frequency	Hz	50/60	50/60	50/60	50/60	50/60	50/60	50/60	50/60	50/60	50/60	50/60	50/60	50/60	50/60				
Fuse	A	16	16	16	16	10	10	10	10	10	13	13	13	16	25				
Protection grade (moist, dust)		IPX4																	
Protection class (electrical)		I																	
Max. Airflow *	l/s m ³ /h CFM					75	270	159									70	252	148
Max. Vacuum	kPa hPa in _{H₂O}					25	250	100									23	230	92
Sound pressure level L _{PA} (IEC 60335-2-69)	dB(A)	69 ± 2																	
Working sound level	dB(A)	60 ± 2																	
Vibration ISO 5349 a _n	m/s ²	≤ 2,5																	
Weight	kg lb	14,5	16	14,5	16	14,5	16	14,5	16	14,5	16	14,5	16	14,5	16	14,5	16		
Filter surface area	m ²	31,9	35,3	31,9	35,3	31,9	35,3	31,9	35,3	31,9	35,3	31,9	35,3	31,9	35,3	31,9	35,3		
Dust class		M	M	H	H	M	M	H	H	M	M	M	M	H	H	M	M		

* measured at turbine

Specifications and details are subject to change without prior notice.

VHS 40/42 Standard and L-class machines

VHS 40, VHS 42											
EU, FR											
	VHS 40 L30 PC	VHS 40 L30 LC FM PC	VHS 40 L40 IC	VHS 40 L40 LC FM IC	VHS 42 L30 PC	VHS 42 L30 LC FM PC	VHS 42 L40 IC	VHS 42 L40 LC FM IC	VHS 40 L30 PC, VHS 40 L30 IC	US	
Possible voltage	220-240	220-240	220-240	220-240	220-240	220-240	220-240	220-240	220-240	110-120	
Power P _{IEC}	1200	1200	1200	1200	1200	1200	1200	1200	1000	1,34	
Connected load for appliance socket	-	-	-	-	2400	2400	2400	2400	-	-	
Mains frequency	50/60	50/60	50/60	50/60	50/60	50/60	50/60	50/60	50/60	50/60	
Fuse	16	16	16	16	16	16	16	16	16	15	
Protection grade (moist, dust)	IPX4										
Protection class (electrical)	I										
Max. Airflow*	75		270		159		70		252		148
Max. Vacuum	25		250		100		23		230		92
Sound pressure level L _{PA} (IEC 60335-2-69)	69 ± 2										
Working sound level	60 ± 2										
Vibration ISO 5349 a _B	≤ 2,5										
Weight	14,5	14,5	16	14,5	14,5	14,5	16	16	14,5	14,5	
	31,9	31,9	35,3	35,3	31,9	31,9	35,3	35,3	31,9	31,9	
Filter surface area	0,5										
Dust class	-	L	-	L	-	L	-	L	-	L	

* measured at turbine

Specifications and details are subject to change without prior notice.

VHS 40/42 M & H-class machines

		VHS 42 MC, VHS 42 HC							
		EU, FR			AU				
		VHS 42 L30 MC PC	VHS 42 L40 MC IC	VHS 42 L30 HC PC	VHS 42 L40 HC IC	VHS 42 L40 MC IC	VHS 42 L30 HC PC	VHS 42 L40 HC IC	
Possible voltage	V	220-240	220-240	220-240	220-240	220-240	220-240	220-240	
Power P _{IEC}	W	1200	1200	1195	1195	1200	1195	1195	
Connected load for appliance socket	W	2400	2400	2400	2400	1100	1100	1100	
Mains frequency	Hz	50/60	50/60	50/60	50/60	50/60	50/60	50/60	
Fuse	A	16	16	16	16	10	10	10	
Protection grade (moist, dust)		IPX4							
Protection class (electrical)		I							
Max. Airflow *	l/s	75							
	m ³ /h	270							
	CFM	159							
Max. Vacuum	kPa	25							
	hPa	250							
	in _{H₂O}	100							
Sound pressure level L _{PA} (IEC 60335-2-69)	dB(A)	69 ± 2							
Working sound level	dB(A)	60 ± 2							
Vibration ISO 5349 a _h	m/s ²	≤ 2,5							
Weight	kg	14,5	16	14,5	16	16	14,5	16	
	lb	31,9	35,3	31,9	35,3	35,3	31,9	35,3	
Filter surface area	m ²	0,5							
Dust class		M	M	H	H	M	H	H	

* measured at turbine
Specifications and details are subject to change without prior notice.

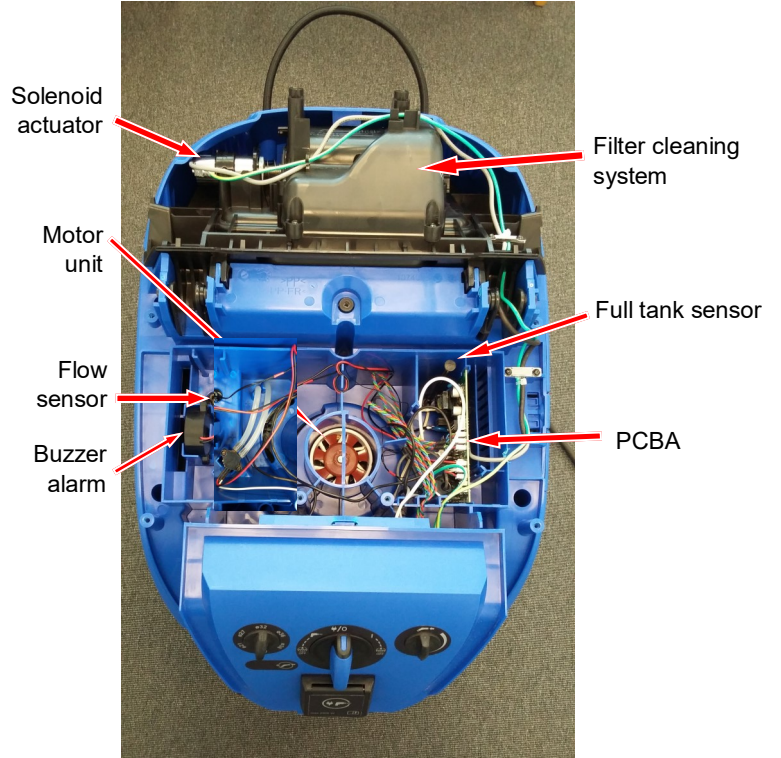
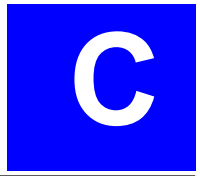

Control panel

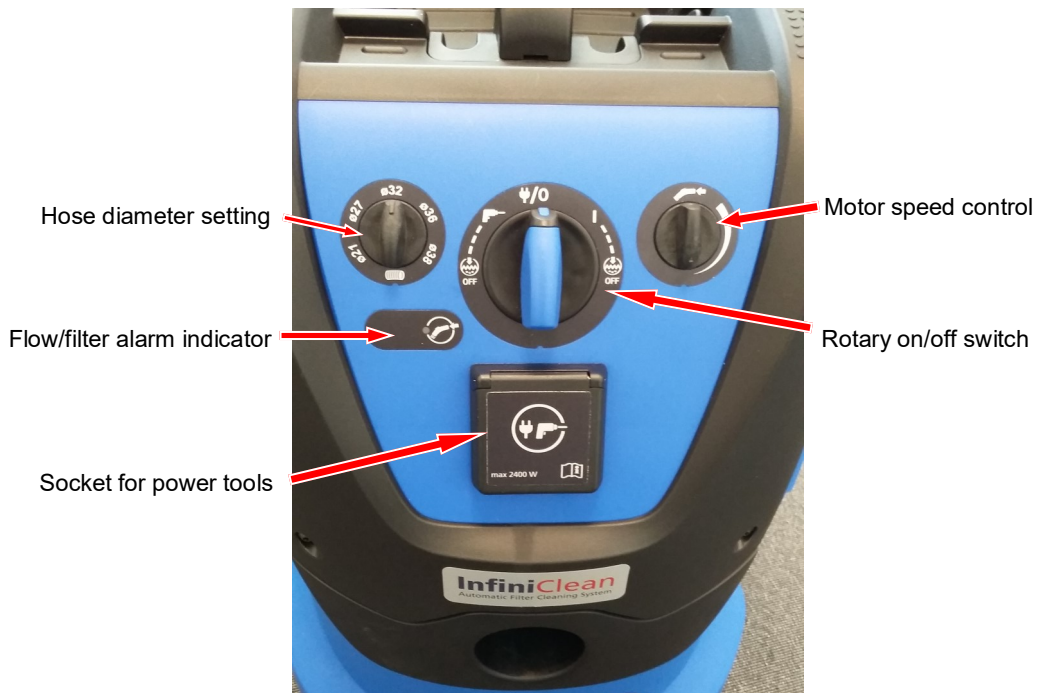

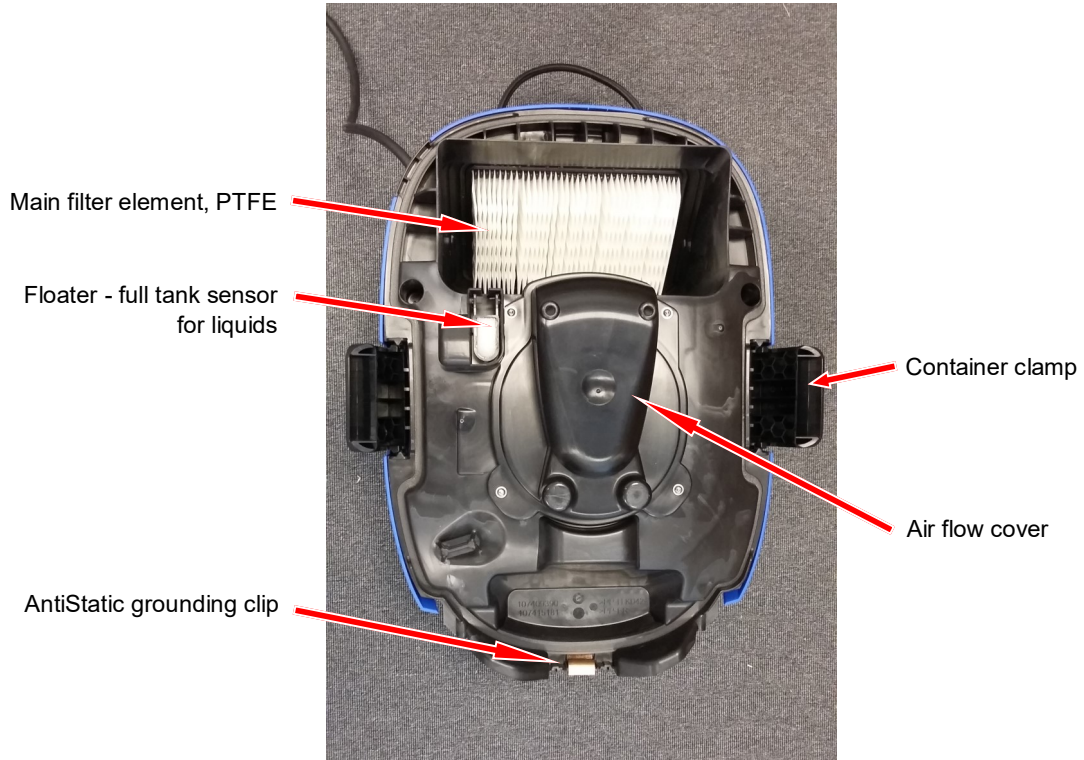

30 ltr container



42 ltr container



Airflow

InfiniClean™

Automatic filter cleaning system

Upstream Main filter (PTFE)
>99,9% filtration

Upstream HEPA cartridge filter
>99,995% filtration
or
>99,97% @ 0,3 μm

1000-1200 Watt
By-pass turbine

MultiFit™
AntiStatic hose inlet

Deflector for reduction
of air/dust velocity and
high container filling

Dust collection

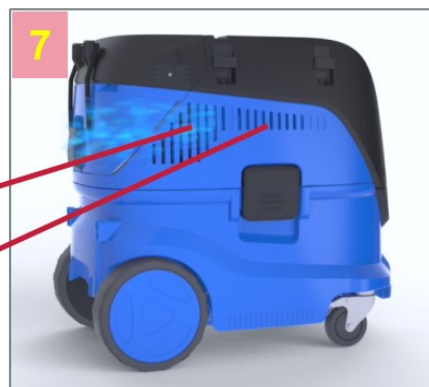
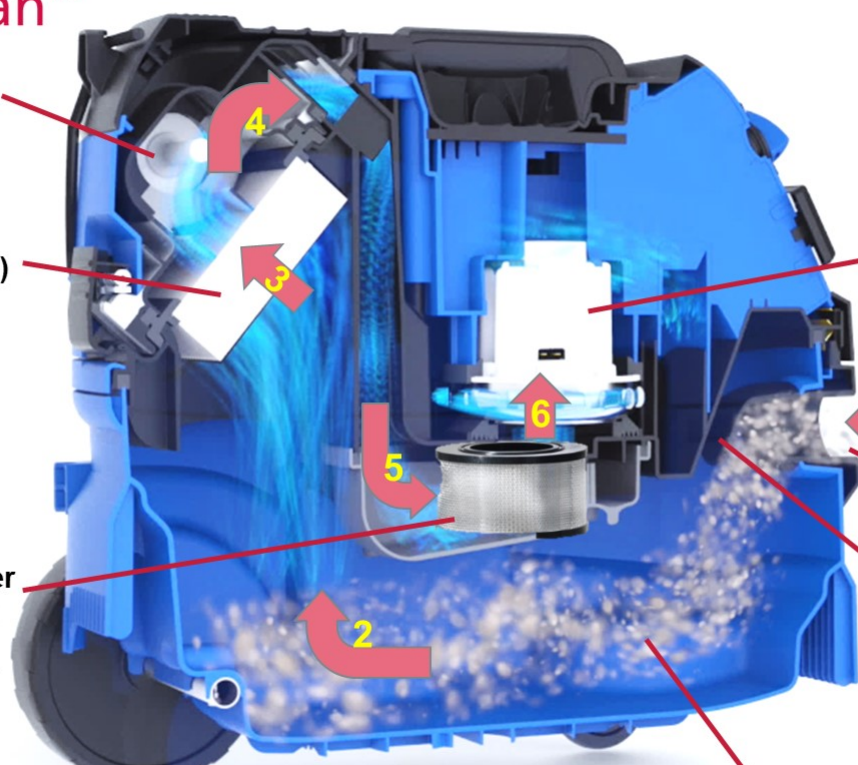

Exhaust "working" air
Exhaust "by-pass" air

Push&Clean - semi-automatic filter cleaning system

Push&Clean™



By sealing the suction opening (1) a high negative pressure is generated inside the dirt tank.

By actuating the cleaning button (2) on the suction head, an air flap is opened on backside of filter.

The negative pressure inside the dirt tank is reduced very quickly and a reversed air pulse flows through the filter.

The dirt adhered to the filter is blown and shaken off, causing it to fall back into the tank.

To optimise the cleaning effect, we recommend that you actuate the cleaning button briefly a number of times.

InfiniClean - Automatic filter cleaning system

Even with extremely fine dust the automatic filter cleaning function allows you to work constantly with the same suction performance without having to manually clean the filter.

A powerful reversed air pulse is activated every 15 seconds keeping the air flow on a high level. The air pulse is created by a solenoid connected to a piston with double-valve. When the valve is opened a pulse is created by difference in pressure between outside and inside of container (dirty side of filter). The negative pressure is reduced very quickly and a reversed air pulse flows through the filter. The dirt adhered to the filter is blown and shaken off, causing it to fall back into the tank.

InfiniClean™

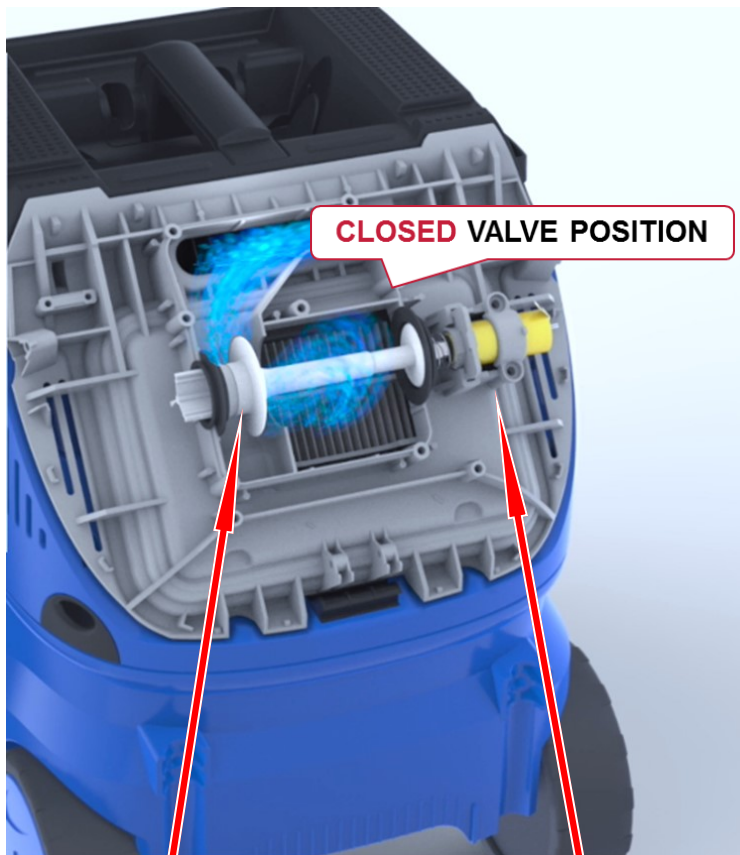

Double valve system

Solenoid actuator

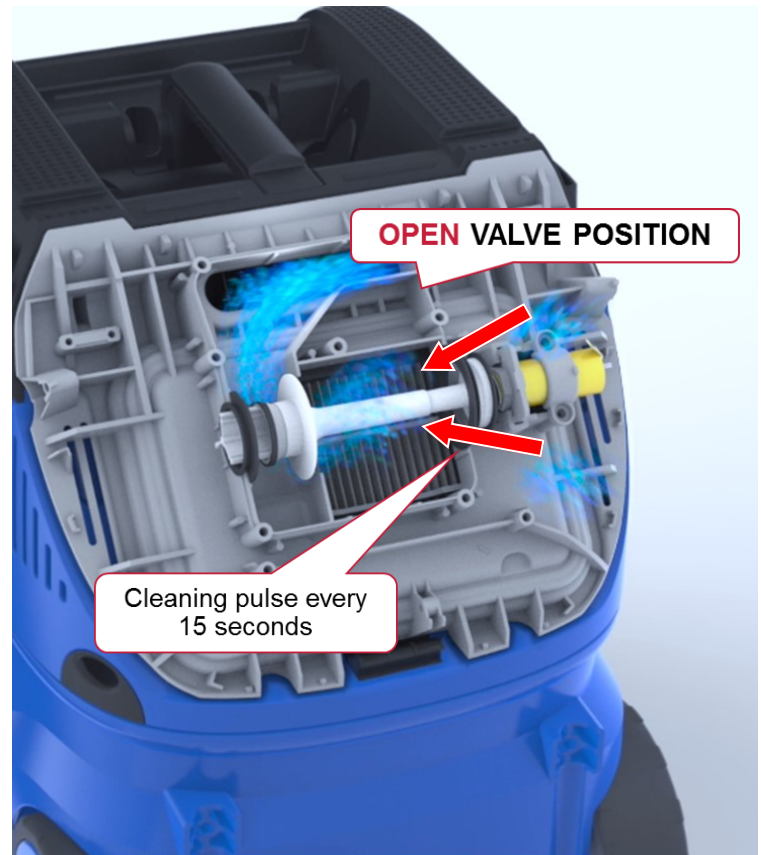

Cleaning pulse every
15 seconds

Motor not working with switch set to "I"

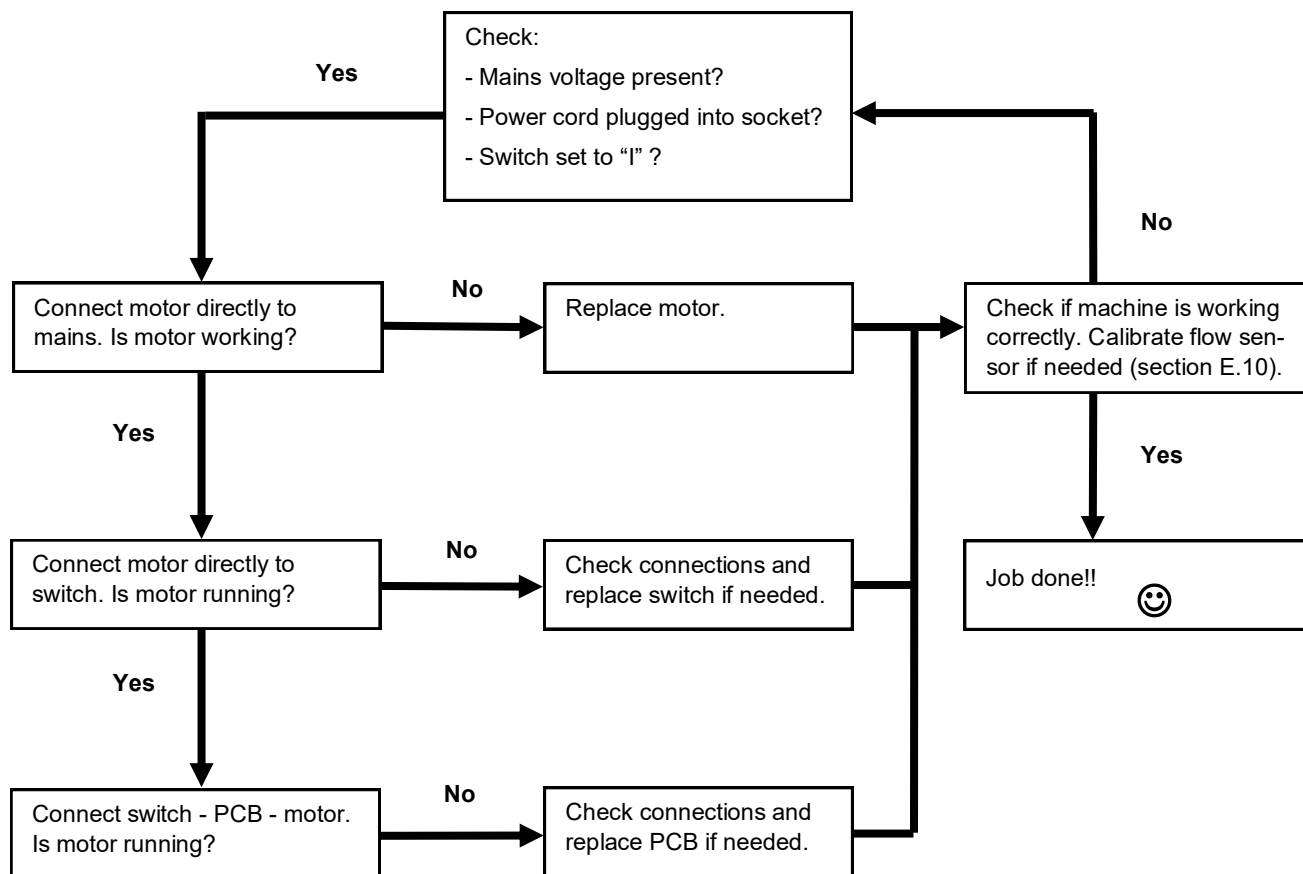

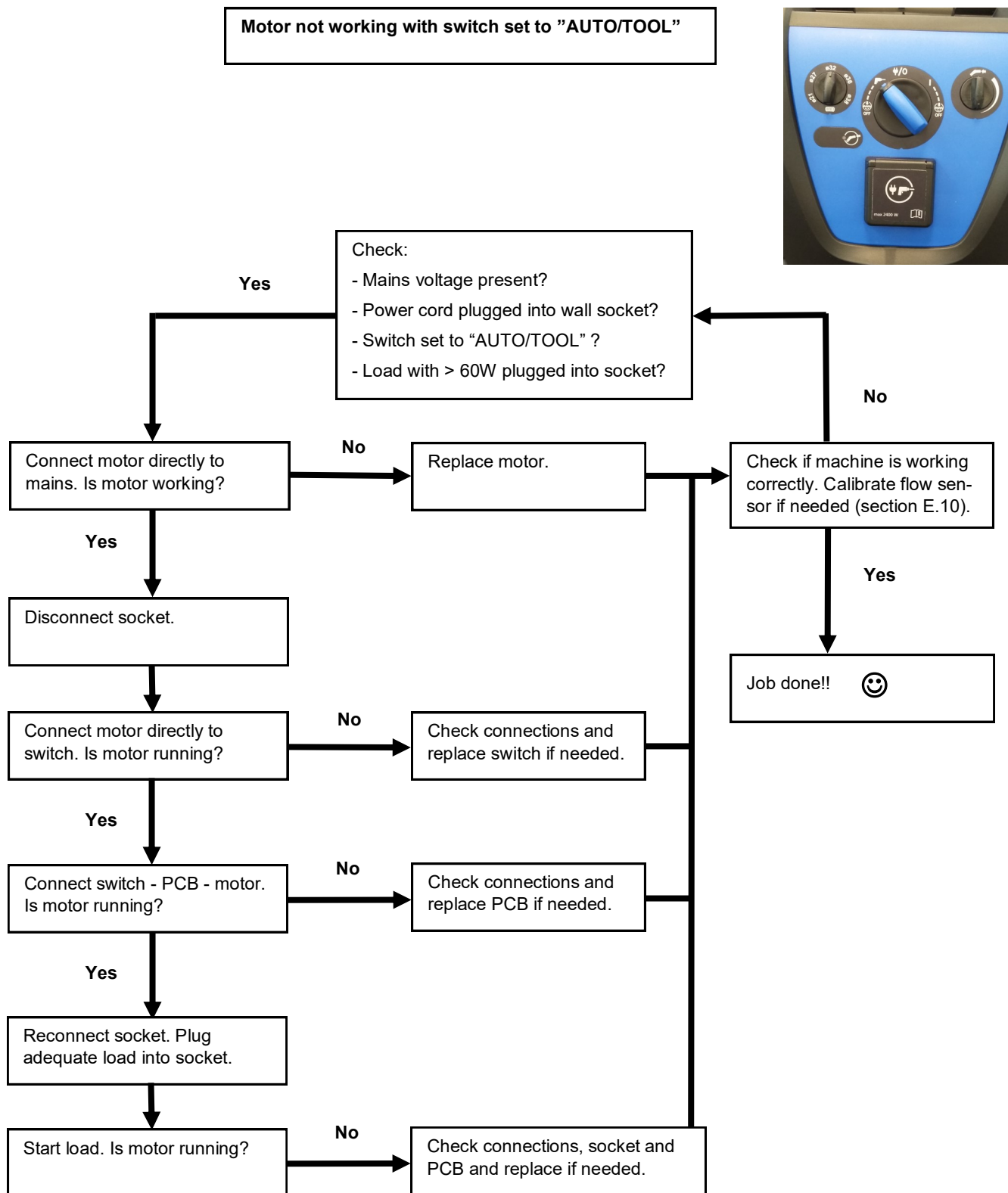

0. Disassembly	17
1. Change motor unit	22
2. Change power cord	23
3. Replace rotary switch	24
4. Replace power socket	25
5. Change hatch back clamp	26
6. Change H-class/HEPA filter	27
7. Change pressure switch	28
8. Change solenoid	29
9. Change flow sensor	30
10. Flow sensor calibration	31
11. Change castor wheels	34



TIP: Unless otherwise stated a TX20 bit is needed for the screws.



WARNING: The upper section of the machine contains live components. Contact with live components leads to serious or even fatal injuries.

Always disconnect the mains plug before disassembly.

Dismount topcover and filter

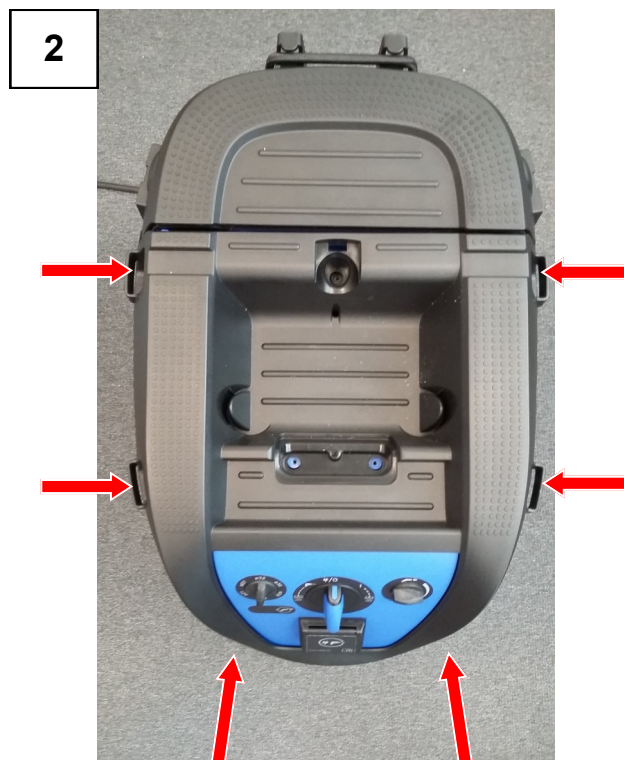

Loosen and lift the top part of the handle with a flat-headed screwdriver and unscrew the lower part of the handle (fig.1).

Unscrew the topcover (fig.2).

TIP: Use a small flat headed screwdriver to lift off the topcover. Lift in both sides.





WARNING: The upper section of the machine contains live components. Contact with live components leads to serious or even fatal injuries.

Always disconnect the mains plug before disassembly.



Open the hatch back and take out the filter (fig.3).

Disconnect and dismount Hatch back

Unscrew the cable relief using a TX10 bit (fig.1).

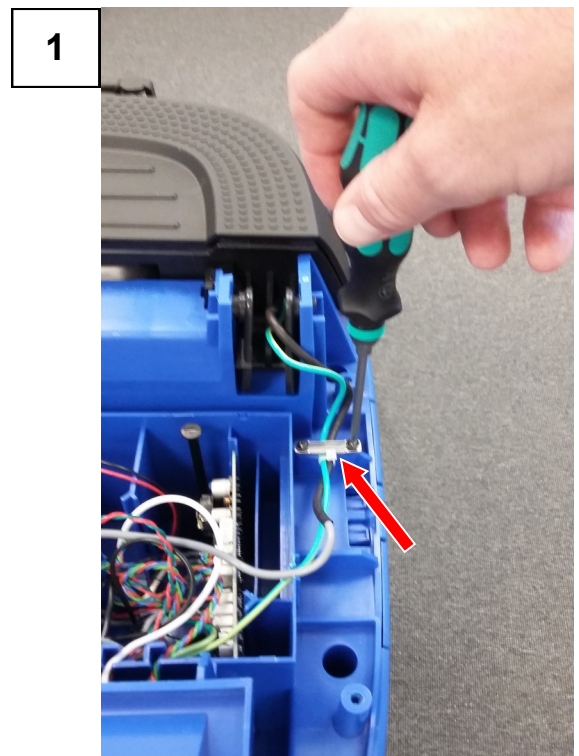



WARNING: The upper section of the machine contains live components. Contact with live components leads to serious or even fatal injuries.

Always disconnect the mains plug before disassembly.

Disconnect and dismount Hatch back
(continued)

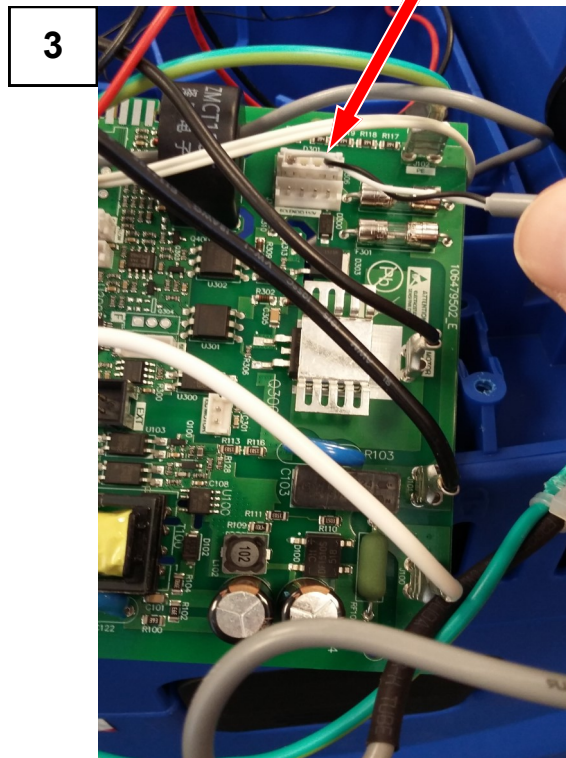
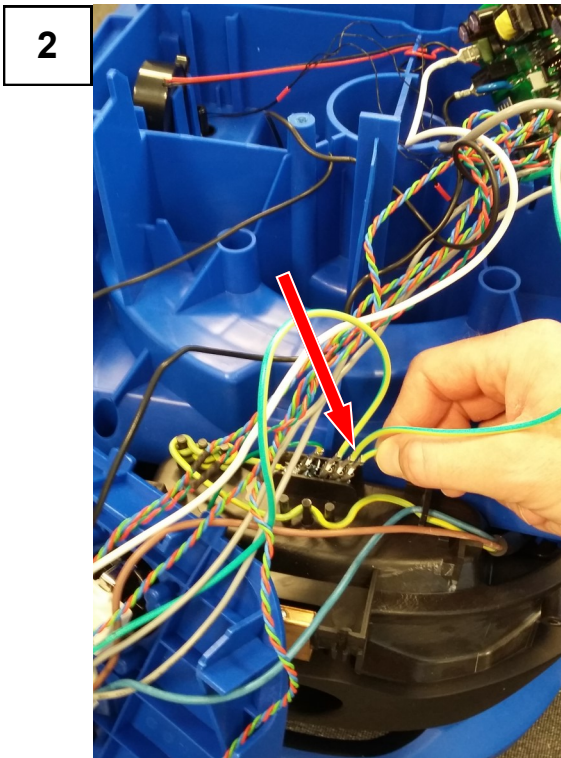

Disconnect the two solenoid wires from the grounding (fig.2) and the PCBA (fig.3).

Disconnect and dismount Hatch back
(continued)

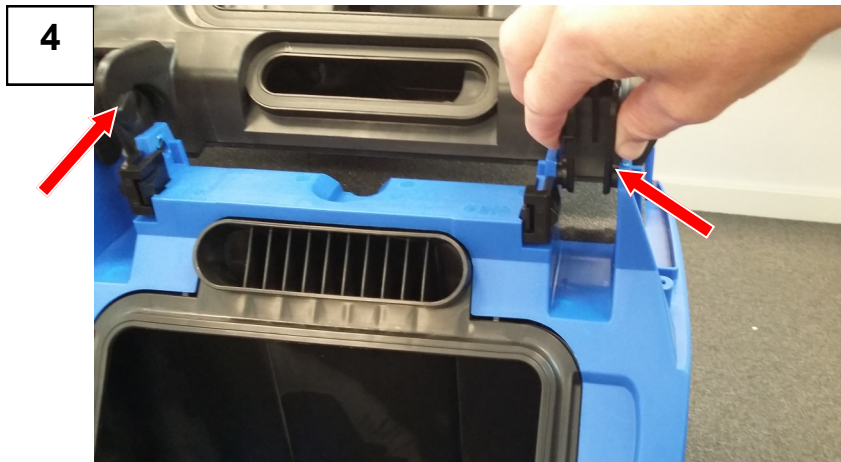

Dismount the hatch back by pressing the hinge in each side (fig.4).

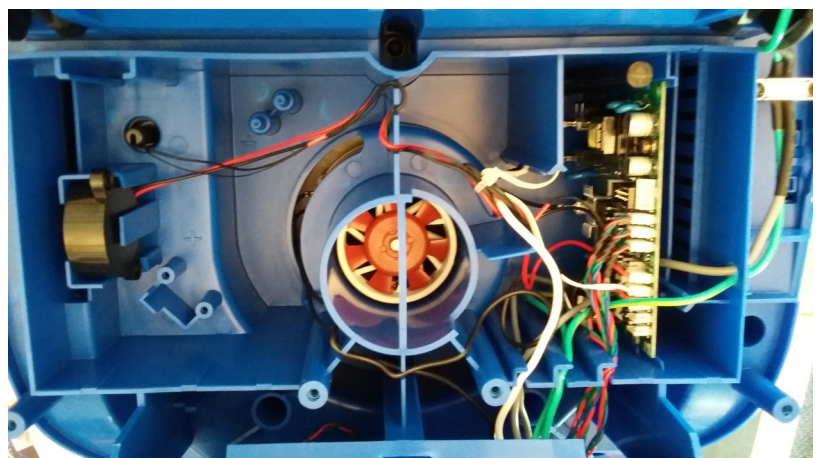
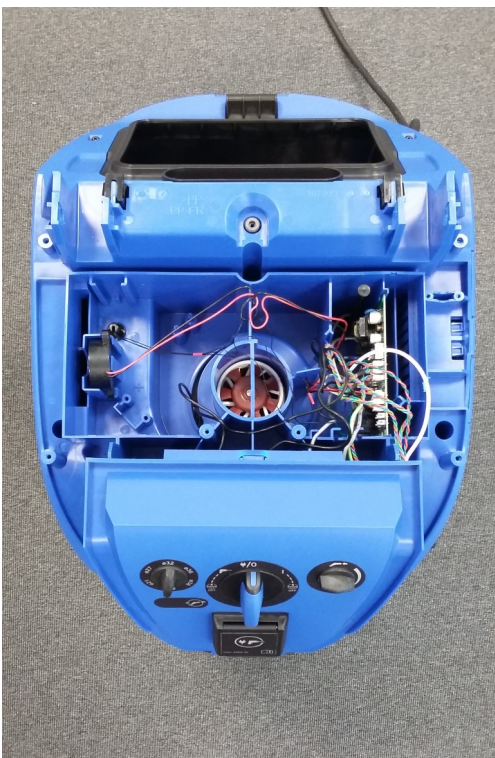



TIP: Before disconnecting wires check if a letter is placed in the plastic next to the connector. This letter will refer to a letter on the PCBA and in the electrical diagrammes.

Example:

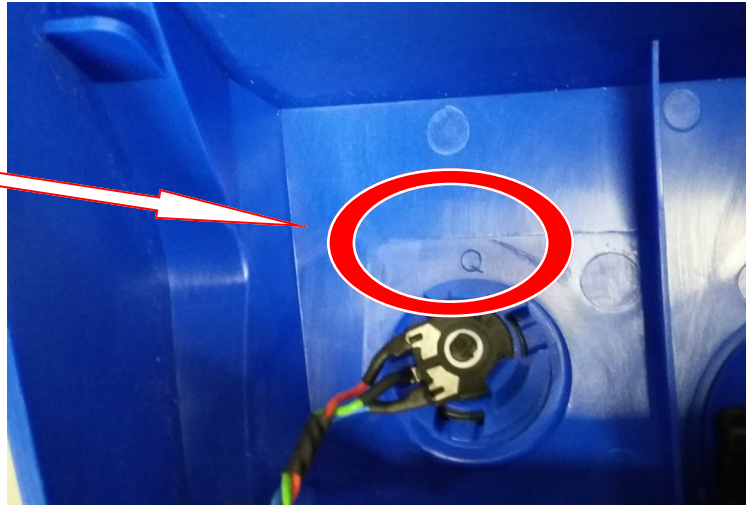
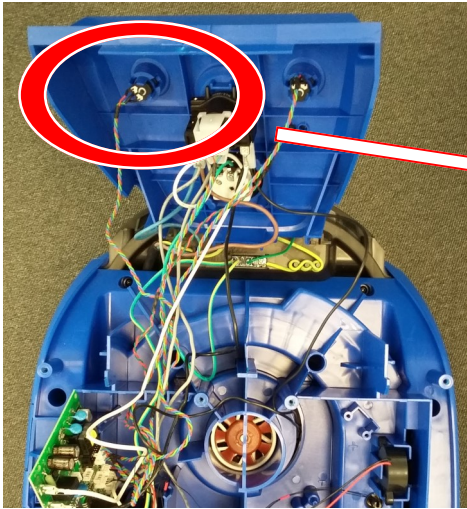

Detail from electrical diagramme:

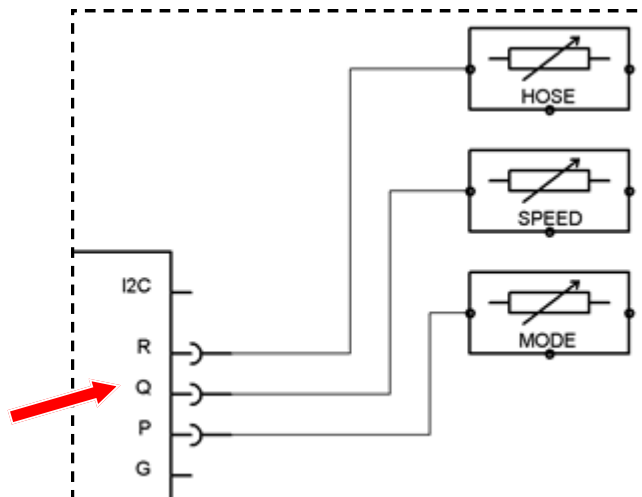

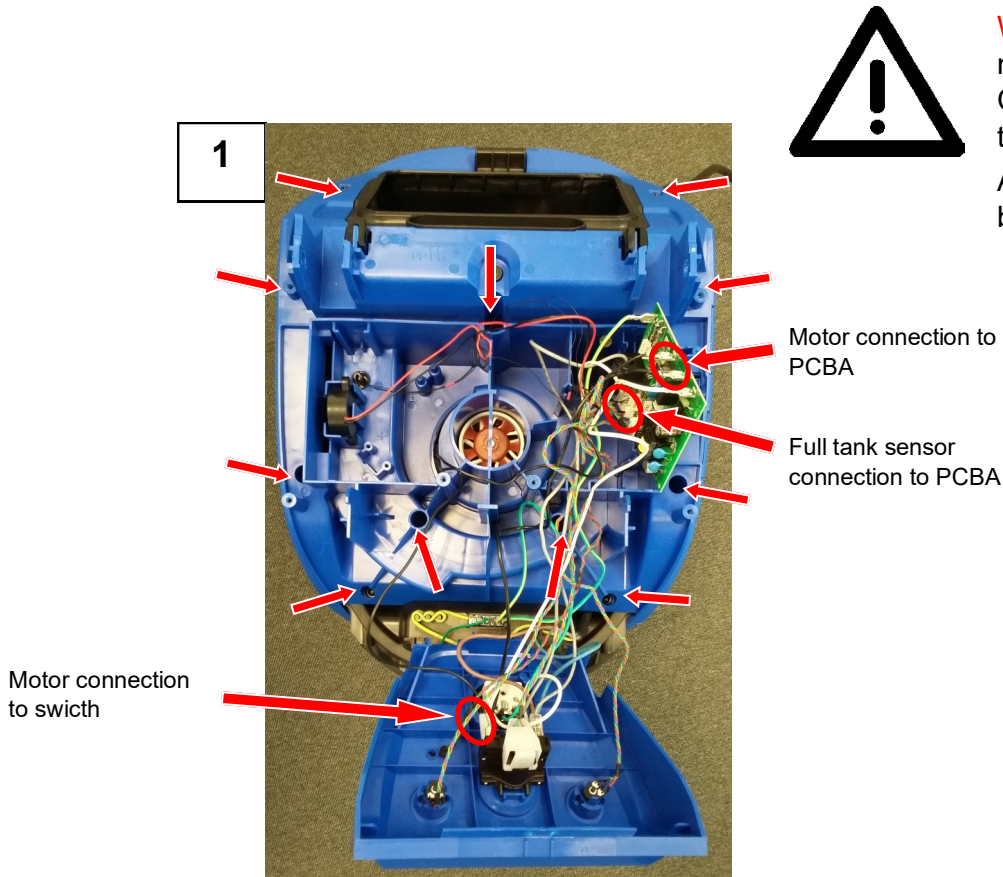

WARNING: The upper section of the machine contains live components. Contact with live components leads to serious or even fatal injuries. Always disconnect the mains plug before disassembly.

Disassemble the handle, top cover, filter and hatch back as described in previous Section E.0. Disconnect the full tank sensor wire and the motor wires from the PCBA and the switch (circles in fig.1).

Unscrew the airguide over the motor (fig.1).

Replace the motor unit (Note: on low voltage motors the carbon brushes can be exchanged once per motor).

Pay close attention to positioning the motor, gaskets and the wires correctly (see fig.2).

Then repeat the process backwards to assemble the machine.



TIP: When placing the airguide into its position put it in vertically.

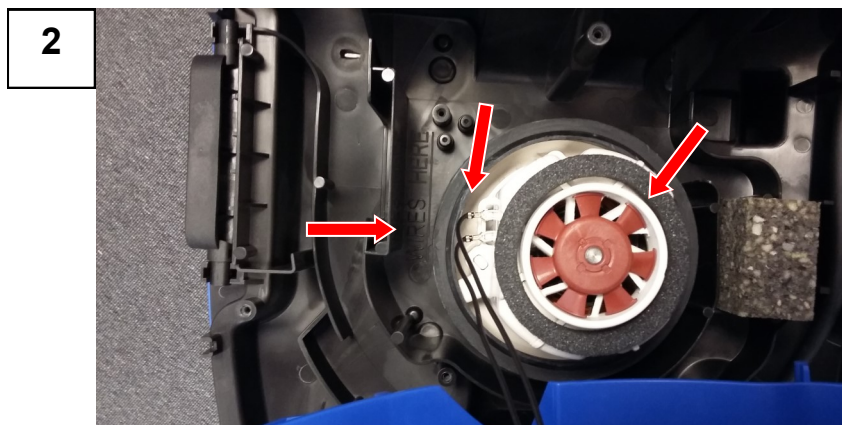

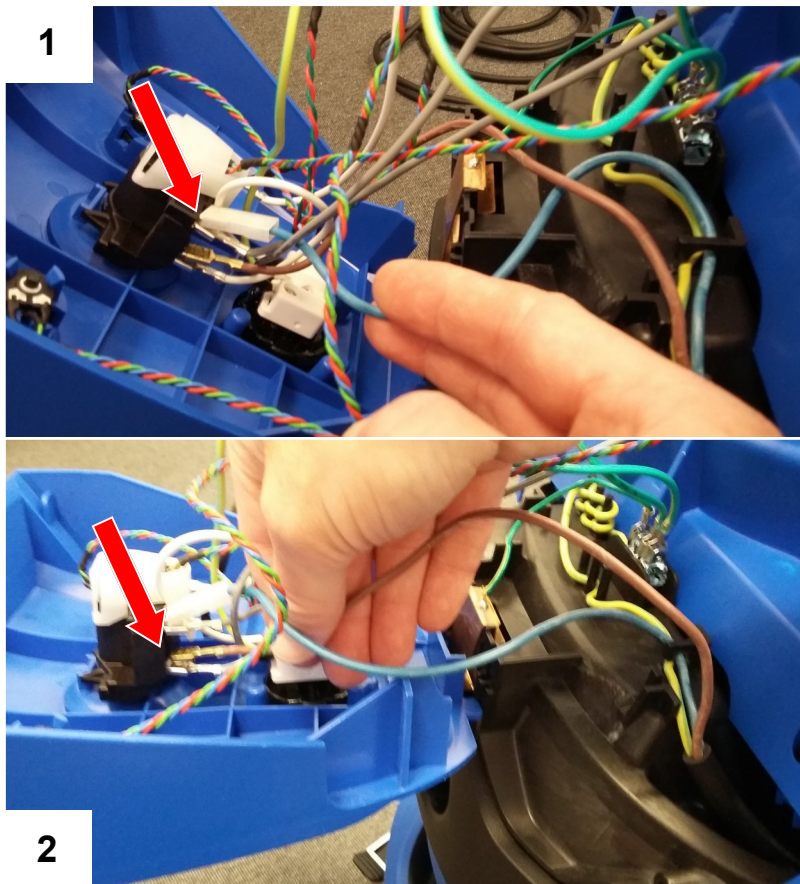

Disassemble the handle, top cover, filter and hatch back as described in previous Section E.0. Disconnect the wires on power cord from their connection points on switch and earth grounding (fig.1-3).

Unscrew the cable relief (use TX10 bit) and pull the cord out of the relief hole (fig.4).

Install new power cord of same type as original.

Then repeat the process backwards to assemble the machine. Be careful to place the cord in the proper cable guides.

4

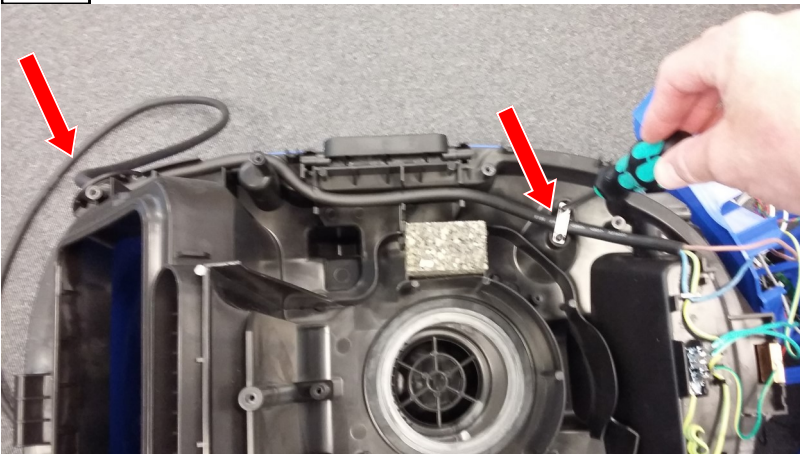

WARNING: The upper section of the machine contains live components. Contact with live components leads to serious or even fatal injuries. Always disconnect the mains plug before disassembly.



WARNING: The upper section of the machine contains live components. Contact with live components leads to serious or even fatal injuries.

Always disconnect the mains plug before disassembly.

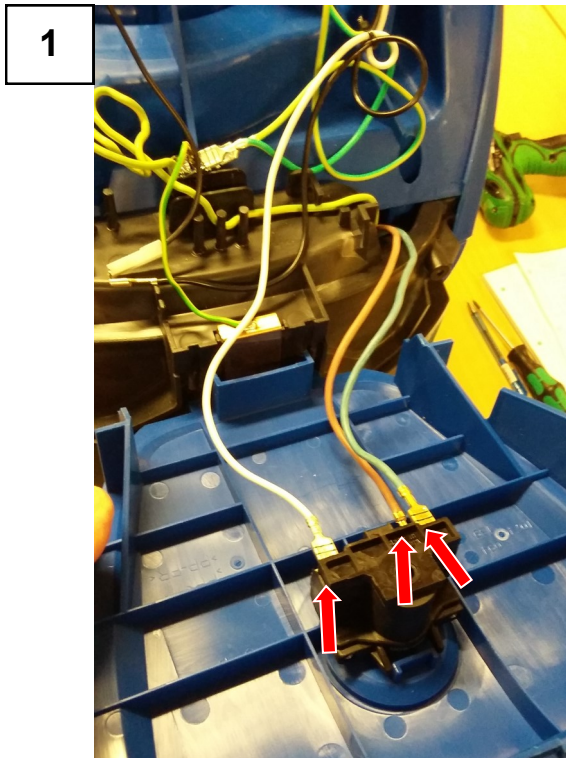

Disassemble the handle and top cover as described in previous Section E.0.

Take off control panel and disconnect the wires on the switch (fig.1).

Unscrew the rotary knob and dismount the rotary switch (fig.2).

Then repeat the process backwards to assemble the machine.



WARNING: The upper section of the machine contains live components. Contact with live components leads to serious or even fatal injuries.

Always disconnect the mains plug before disassembly.

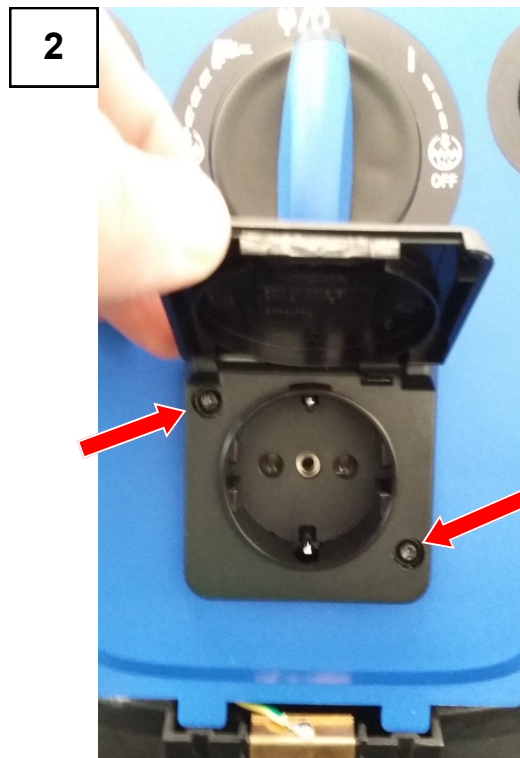
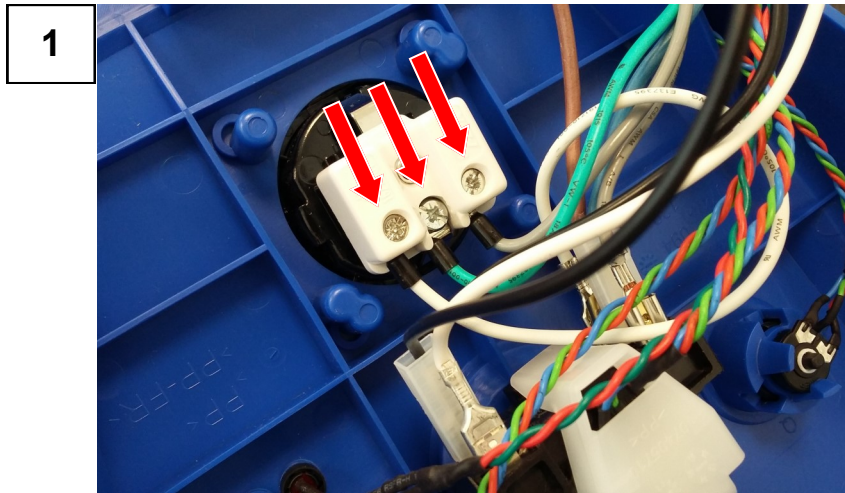

Disassemble the handle and top cover as described in previous Section E.0.

Take of control panel and disconnect the wires on the power socket (fig.1). Unscrew the power socket and replace it (fig.2).

Then repeat the process backwards to assemble the machine.

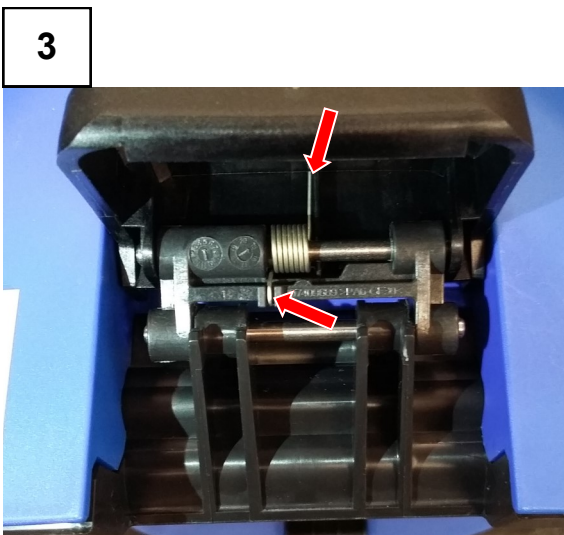
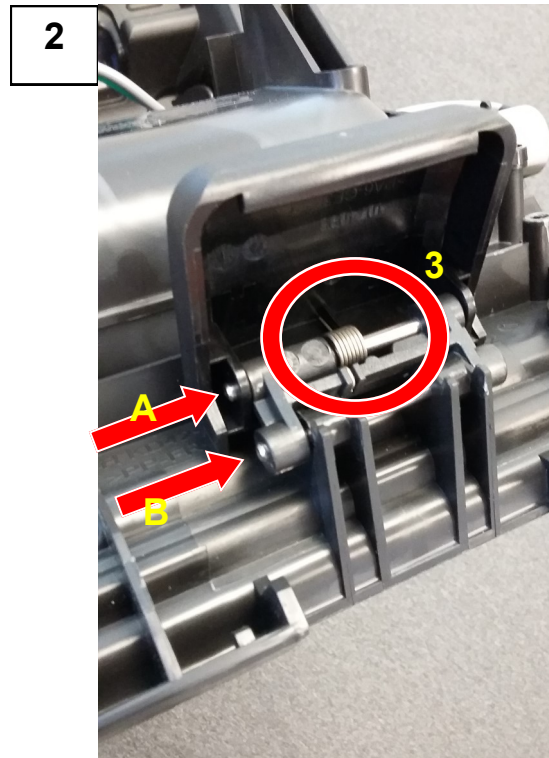
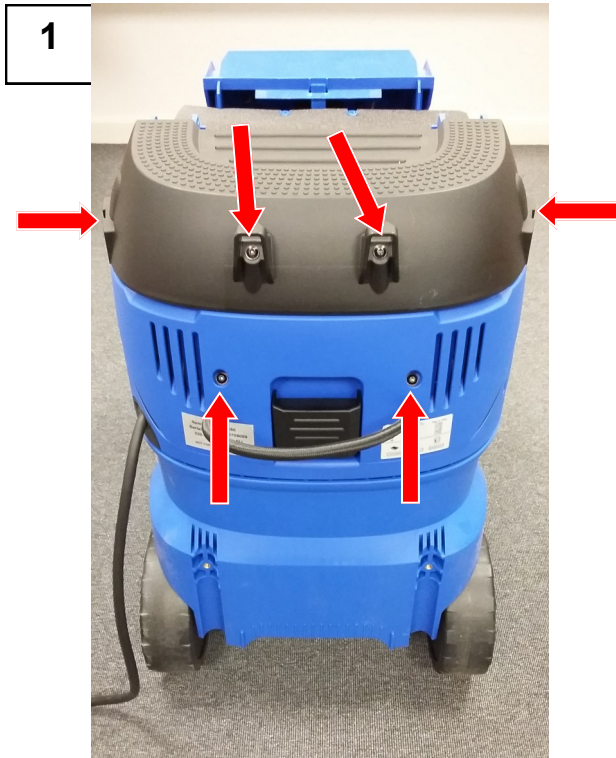

Disassemble the handle and top cover as described in previous Section E.0.

Unscrew the two plastic covers on the hatch back (fig.1).

Dismount the clamp by pressing the outer metal pin "A" from left side (fig.2). Notice position of the spring (fig.3).

Dismount the clamp lever by pressing the outer metal pin "B" from left side (fig.2).

Replace the clamp.

Repeat the process backwards to assemble the machine.

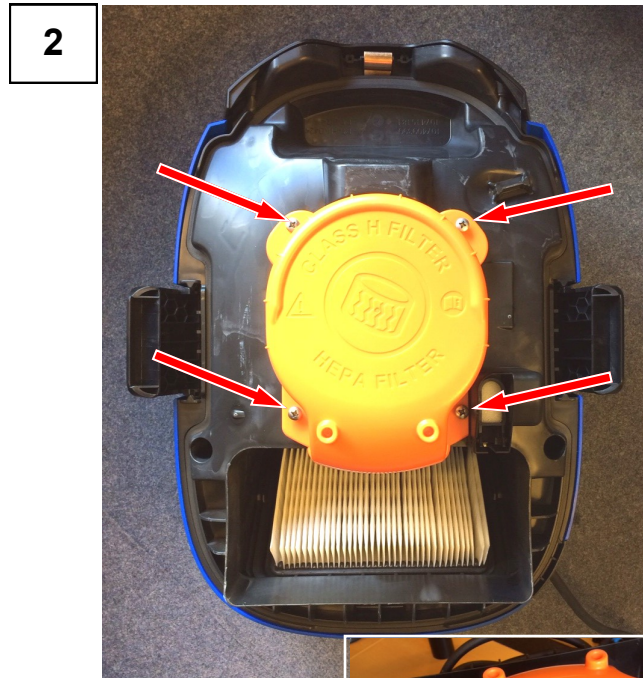

Open the container clamps (fig.1) and turn motor head upside down. Unscrew and remove the orange filter cover (fig.2).

Take off H-class/HEPA filter and dispose it in a safe manner.



WARNING: Filter might be contaminated by hazardous dust. Wear a P2 breathing mask and avoid spreading harmful dust.

Install new filter gasket and make sure it is in correct position (fig.3). Install new H-class/HEPA filter (fig.4).

Re-mount the orange filter cover and fasten all 4 screws sufficiently to make sure a proper sealing is obtained.

Turn motor head and place on container. Close the clamps.

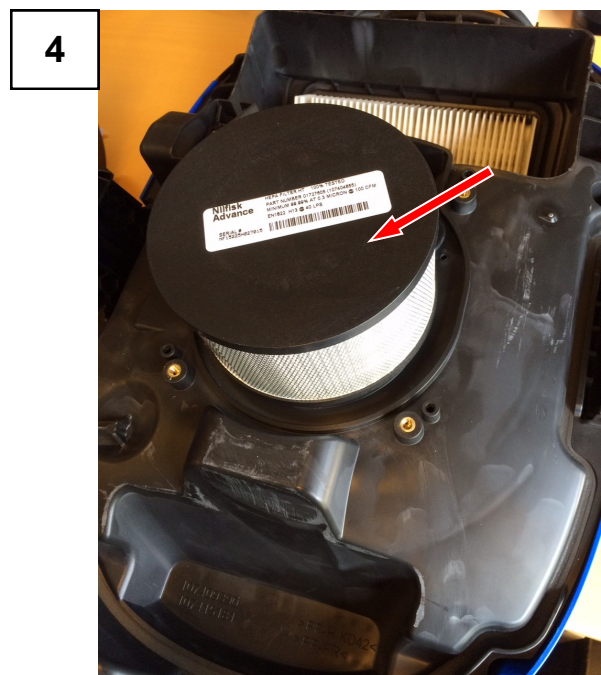
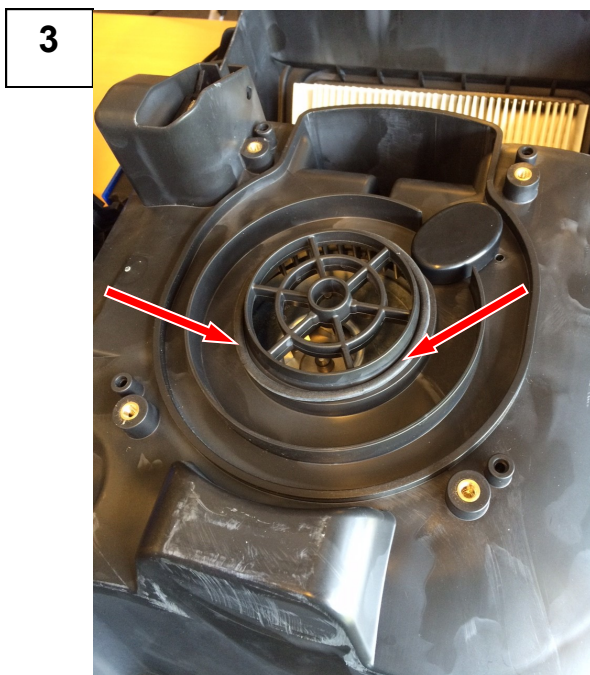



WARNING: The upper section of the machine contains live components. Contact with live components leads to serious or even fatal injuries.

Always disconnect the mains plug before disassembly.

1

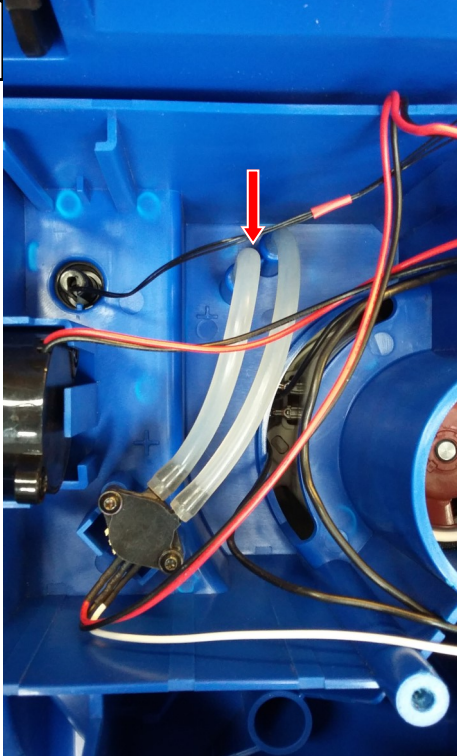

Disassemble the handle and top cover as described in previous Section E.0.

If the pressure difference 20-30 mbar over the '+' connector the pressure is ok (fig.1).

Disconnect the pressure switch wire from the PCBA (fig.2).

Unscrew the pressure switch (fig.3) and replace it incl wiring.

Repeat the process backwards to assemble the machine.

2

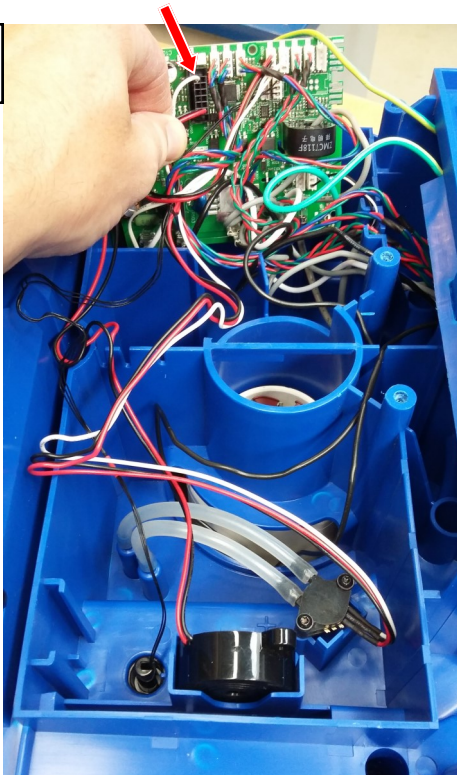

3

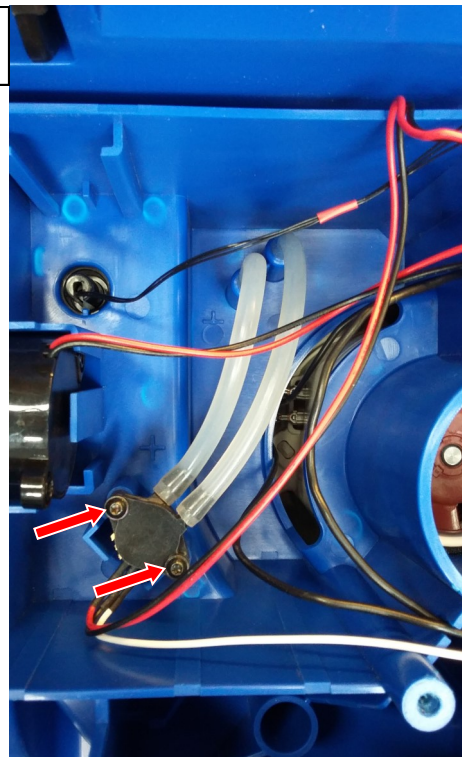

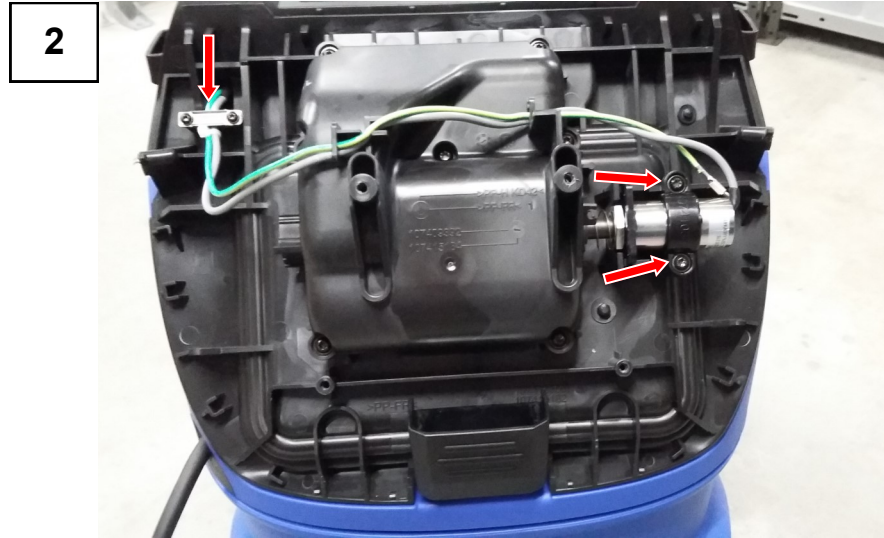

WARNING: The upper section of the machine contains live components. Contact with live components leads to serious or even fatal injuries.

Always disconnect mains plug before disassembly.

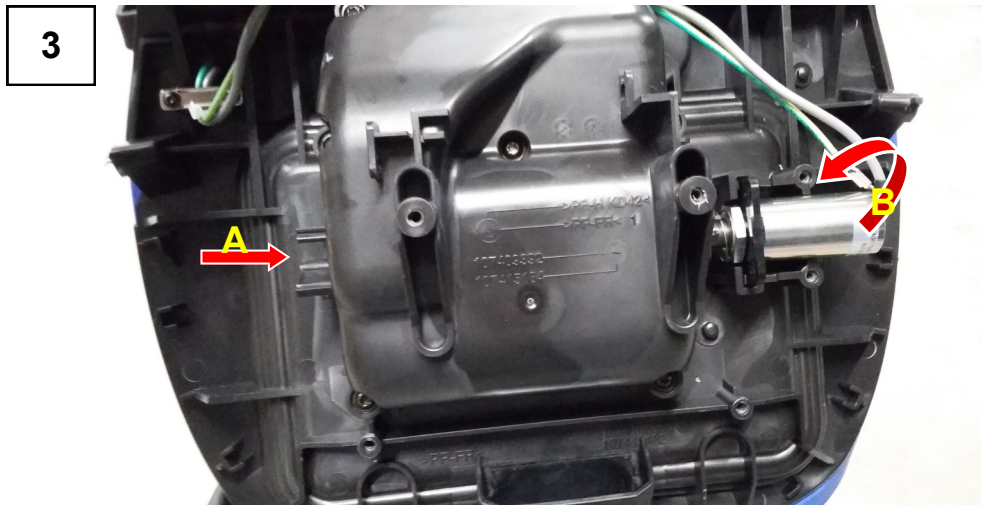

Disassemble the handle and top cover as described in previous Section E.0.

Unscrew the two plastic covers on the hatch back (fig.1).

Disconnect the solenoid wires from PCBA and earth clip.

Relieve the solenoid and unscrew the cable relief (fig.2).

Press the piston "A" to the right, lift the solenoid "B" and turn it approx 45° (fig.3).

While observing the spring between piston and solenoid carefully take out the solenoid.

Replace the solenoid (including wiring) and make sure it is correct assembled and placed into correct position.

Repeat the process backwards to assemble the machine.

If needed the complete hatch back can be replaced. Unscrew the two plastic covers on the hatch back (fig.1) and reuse the covers.



WARNING: The upper section of the machine contains live components. Contact with live components leads to serious or even fatal injuries.

Always disconnect the mains plug before disassembly.

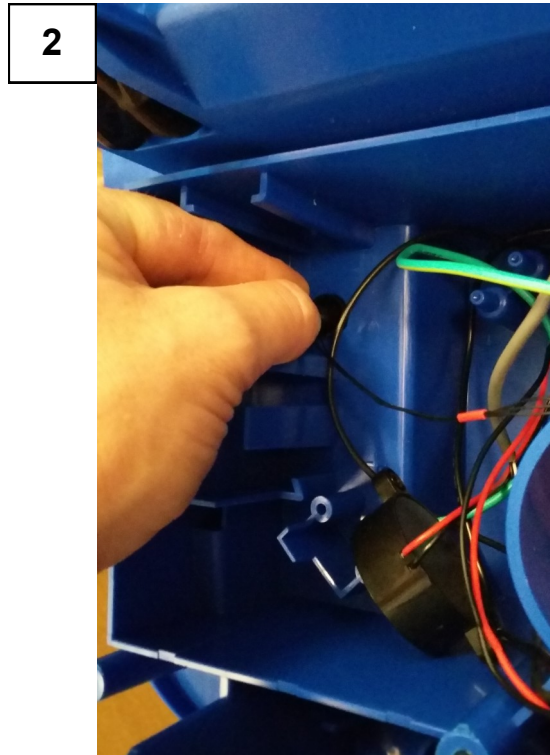
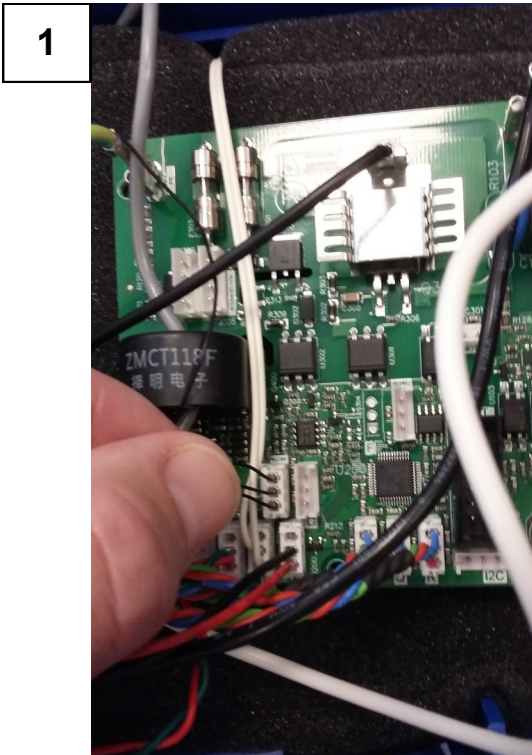

Disassemble the handle and top cover as described in previous Section E.0.

Disconnect the flow sensor from the PCBA (fig.1).

Take out the flow sensor and replace it (fig.2).

Repeat the process backwards to assemble the machine.

When?

Flow sensor calibration should be carried out, if the PBCA or flow sensor has been changed during service. Also it is recommended to do a flow sensor calibration, if the motor unit has been replaced.

1

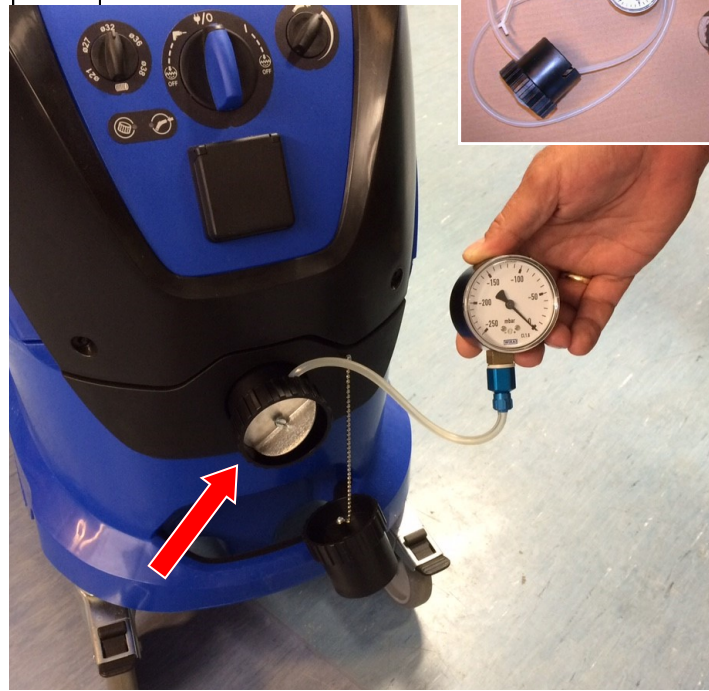
2

To test whether flow sensor calibration is needed adjust the hose diameter selector to "ø32" (fig.1), insert the air restrictor with manometer (P/N: 62480 + P/N 40434) into the container inlet (fig.2) and adjust to 165 mbar. Then preheat the machine for 5-6 minutes.

- 1) Adjust the air restrictor to a pressure level at "level A": the machine should start beeping.
- 2) Adjust the air restrictor towards pressure "level B": at the latest when the pressure level reaches "level B" the machine should stop beeping.

If the machine does not start and stop beeping as described in 1) and 2) recalibration is needed (see next pages)

Machine	220-240V	100-120V
Level A:	170 mbar	125 mbar
Level B:	160 mbar	115 mbar



WARNING: The upper section of the machine contains live components. Contact with live components leads to serious or even fatal injuries. Always disconnect mains plug before disassembly.

1

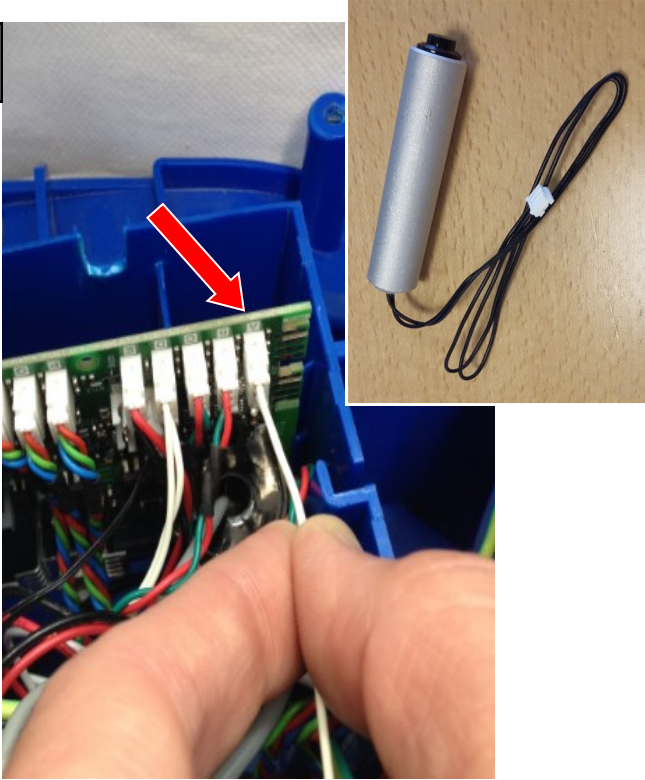

Switch off the machine, disconnect the mains plug and take off handle and top cover as described in previous Section E.0.

Connect the calibration switch tool (P/N: 107416579) to connector (A) on the PCBA (fig.1).

Position the hose diameter selector to position "Ø21" and the motor speed control (only relevant for IC-machines) in max position (fig.2).

Insert the air restrictor with manometer (P/N: 62480 + P/N 40434) into the container inlet (fig.3).

2



3

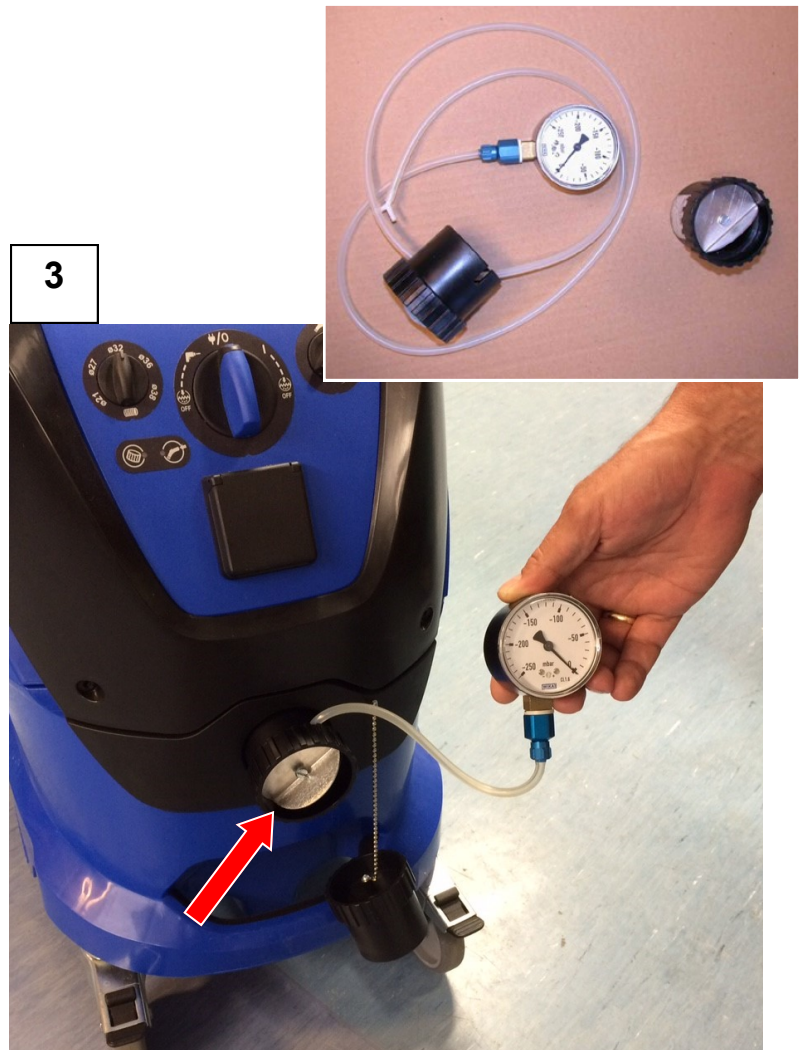

Continued



WARNING: The upper section of the machine contains live components. Contact with live components leads to serious or even fatal injuries.

4



Reconnect the mains plug and switch ON the machine to start the suction unit.

Adjust/rotate the air restrictor (fig.4) until the manometer is indicating the following under pressure level:

165±5 mbar on 220-240V machines
120±5 mbar on 100-120V machines

The machine will now run. Depending on the service condition and machine temperature the buzzer alarm might be activated.

Keep the machine turned ON for **5-6 minutes** to pre-heat the air flow system. Check that the manometer is still indicating the correct under pressure level.

After pre-heating press the calibration switch button connected to the PCBA for 5 seconds (fig.5).

Observe that the machine begins to alternate its internal buzzer. This signals that the automatic calibration process is started.

Let the machine run and wait approximately 1 minute until the suction unit re-starts and the buzzer signal is deactivated.

The air flow system is now calibrated.

Switch OFF the machine and disconnect the mains plug.

Disconnect the calibration switch tool from the PCBA.

Make sure the PCBA is mounted correctly and reassemble the machine.

5

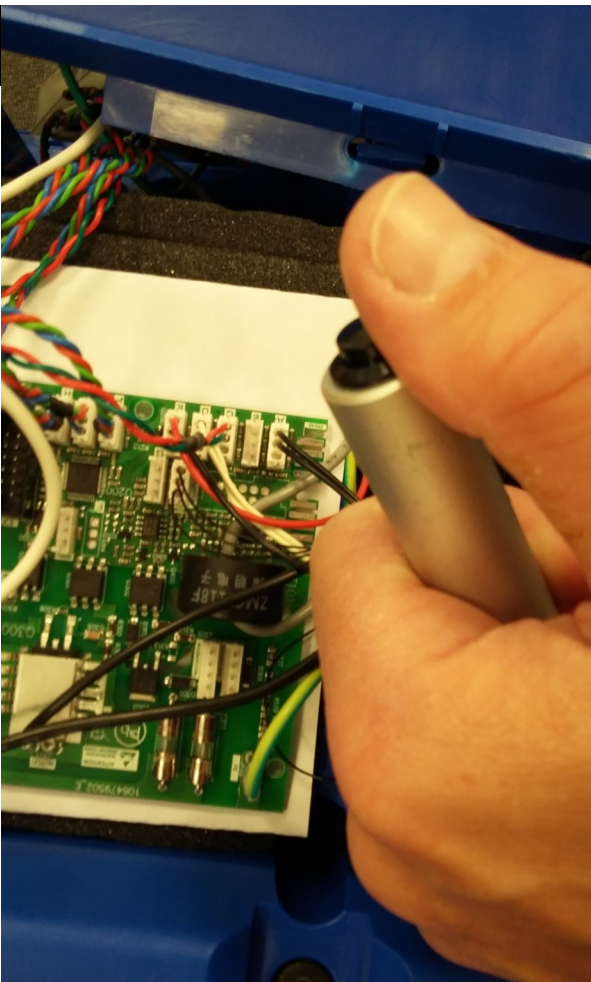

- Unscrew the defect wheel including the insert connected to the container.
- Mount the parts in the order laid out, insert, washer, wheel, screw. To improve the strength and fixation of the castor wheel it is recommended to use Loctite 275 or similar on the screw.

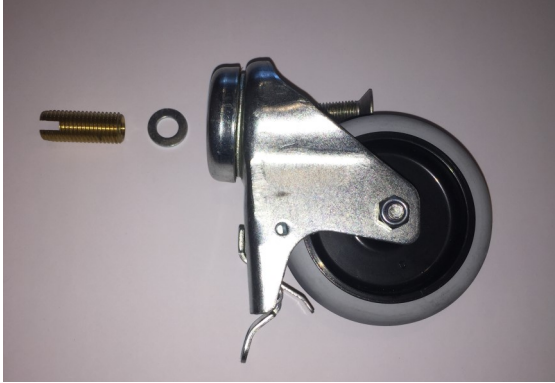

- Tighten the screw into the insert. Use torque wrench and tighten with 10Nm.

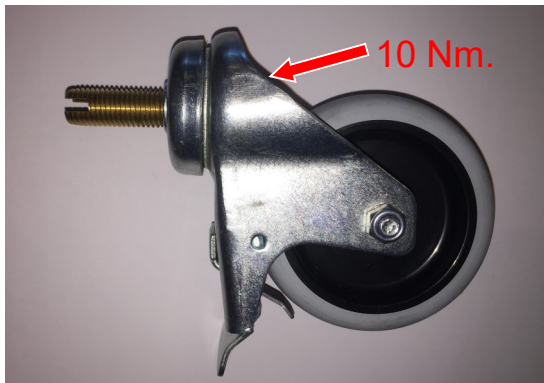

- Mount the insert into the container. Use torque wrench and tighten with 6Nm.

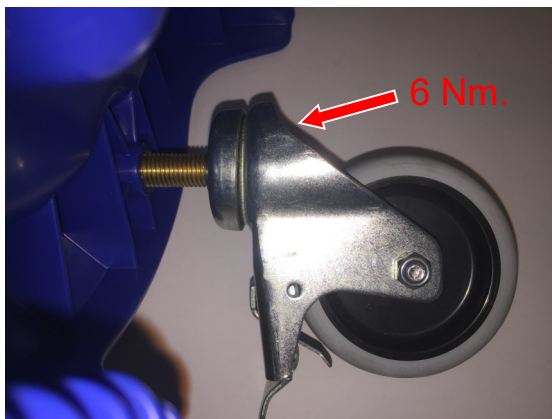

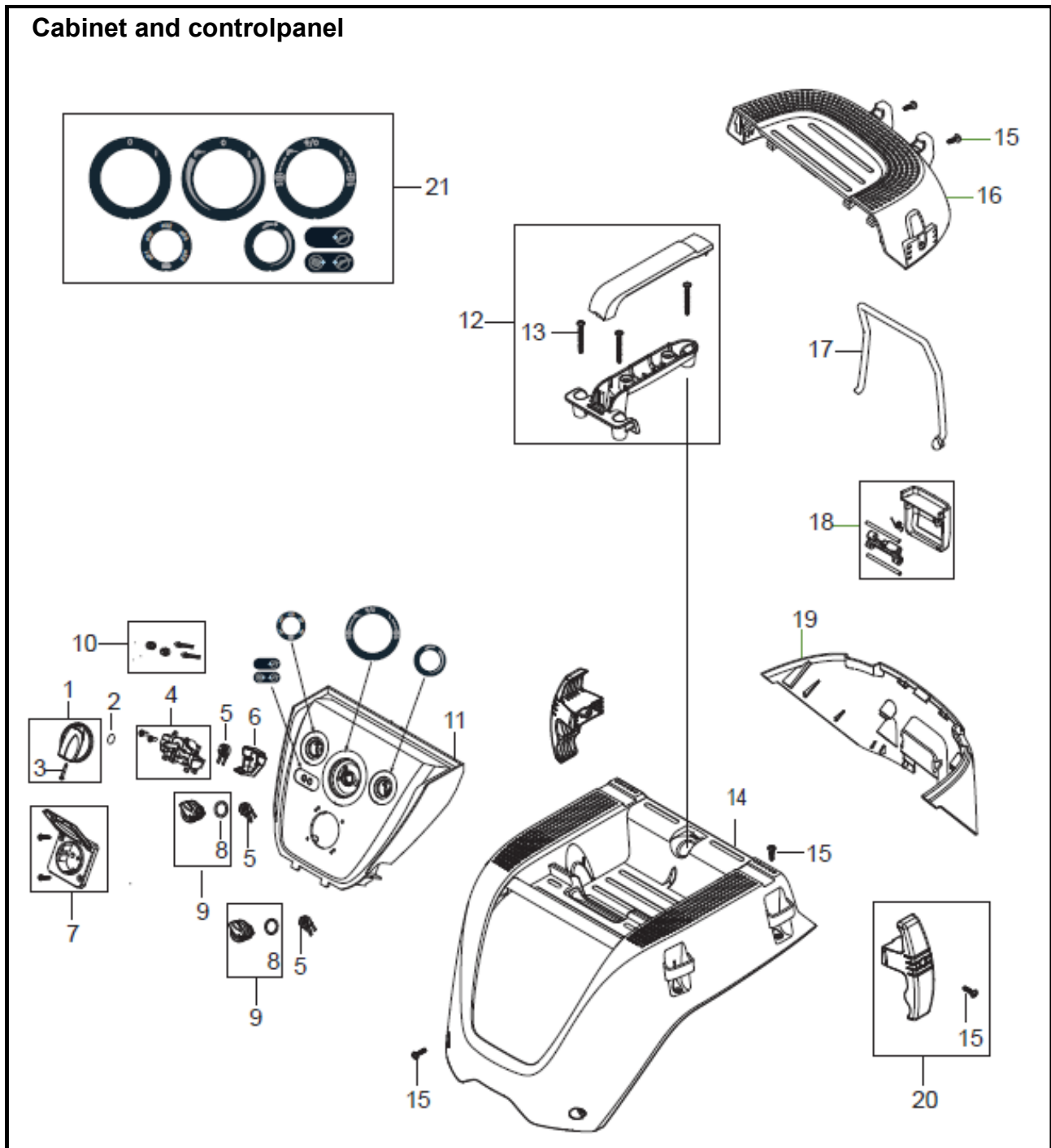
Cabinet and controlpanel

Suction unit, floater / reed sensor, flow sensor, buzzer and PCBA

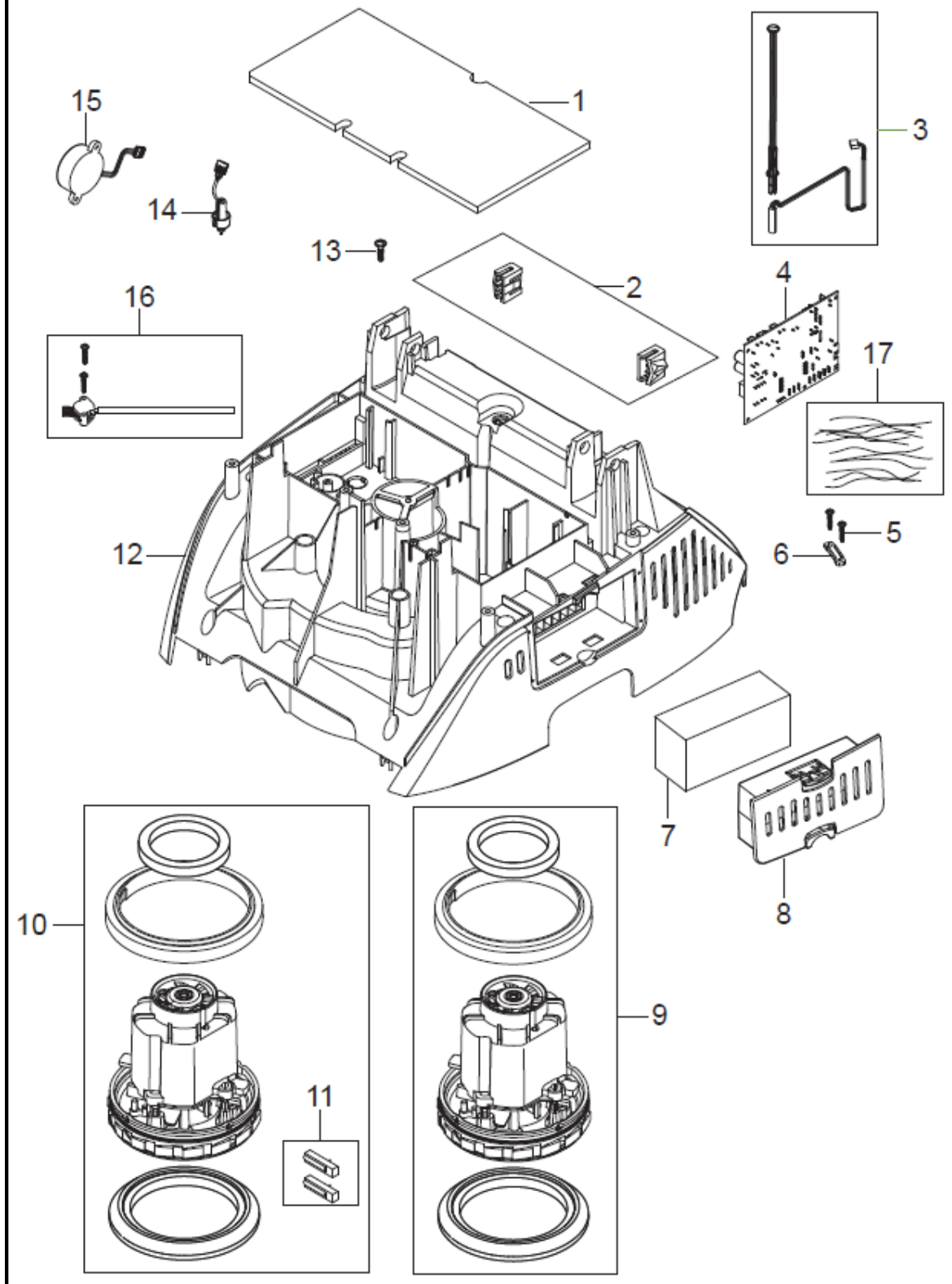

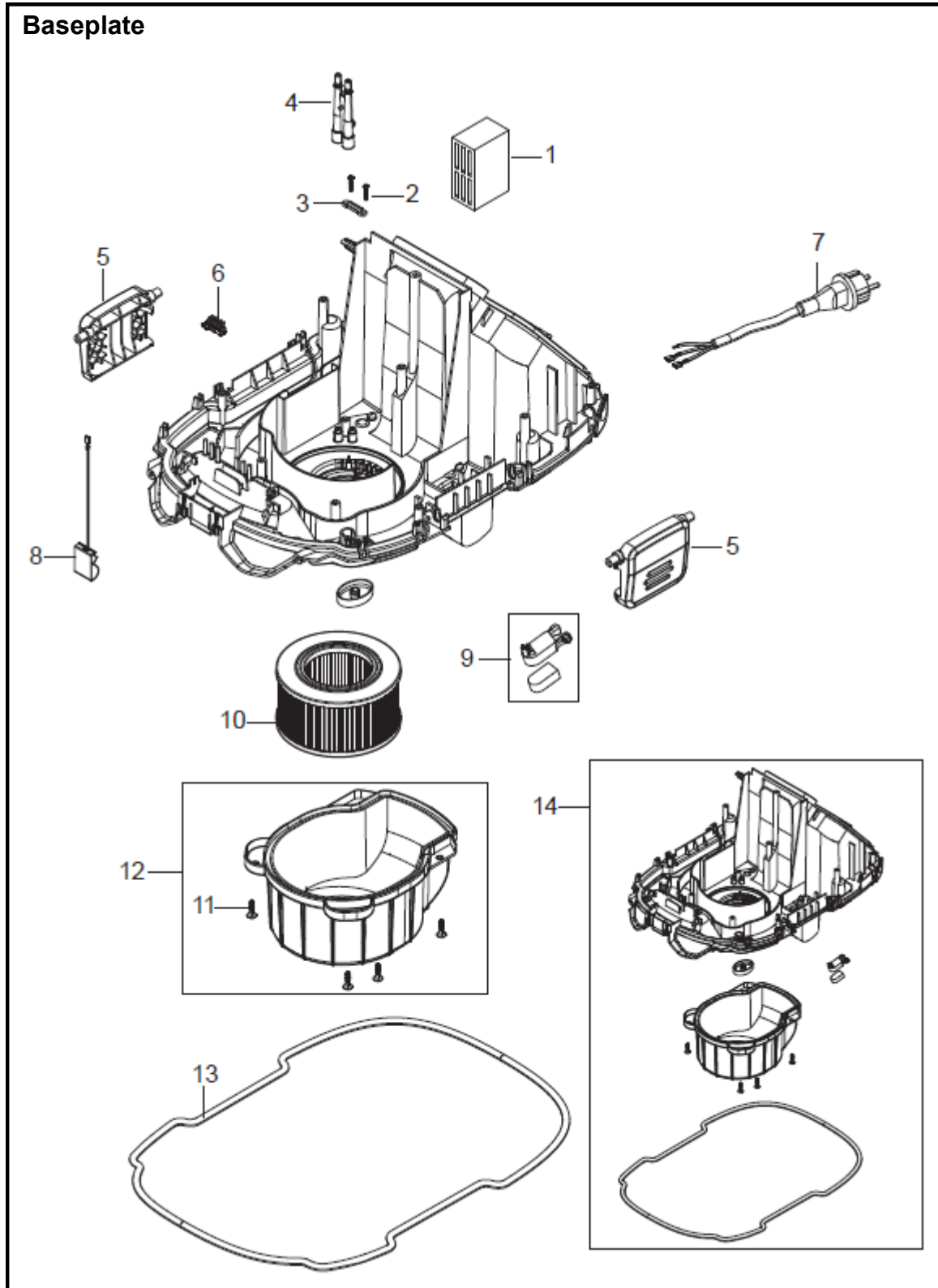

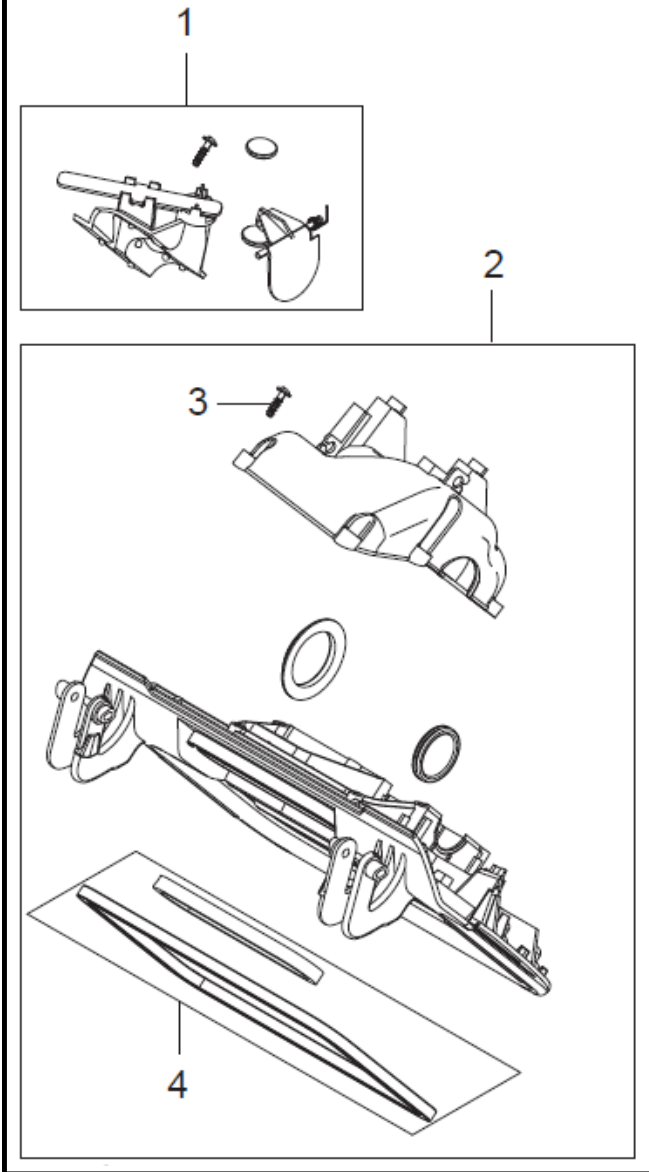
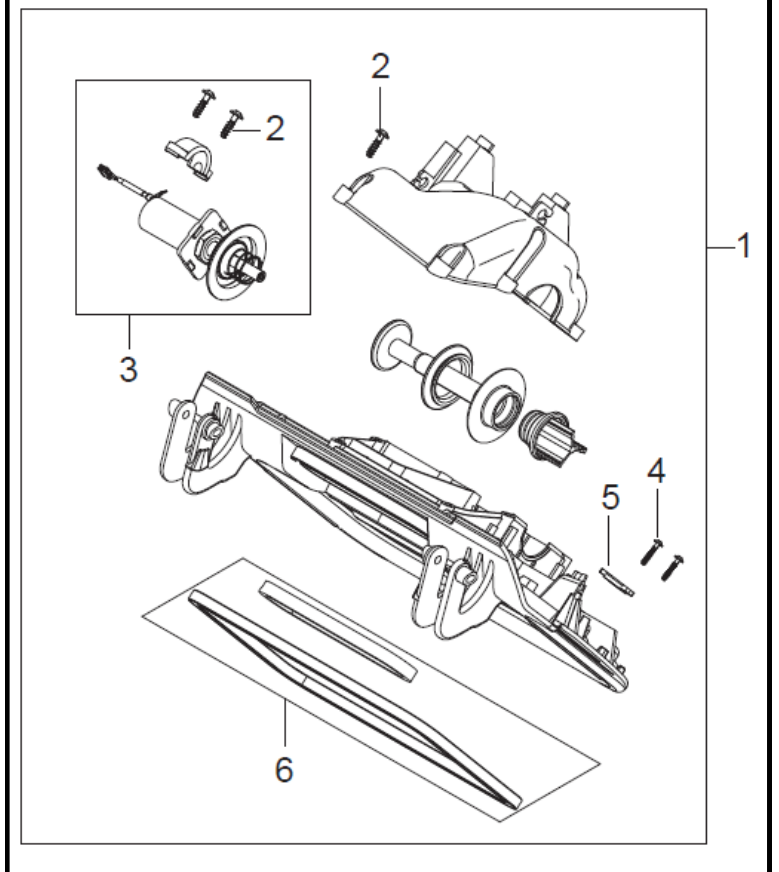
Filter cleaning system - PC

Filter cleaning system - IC

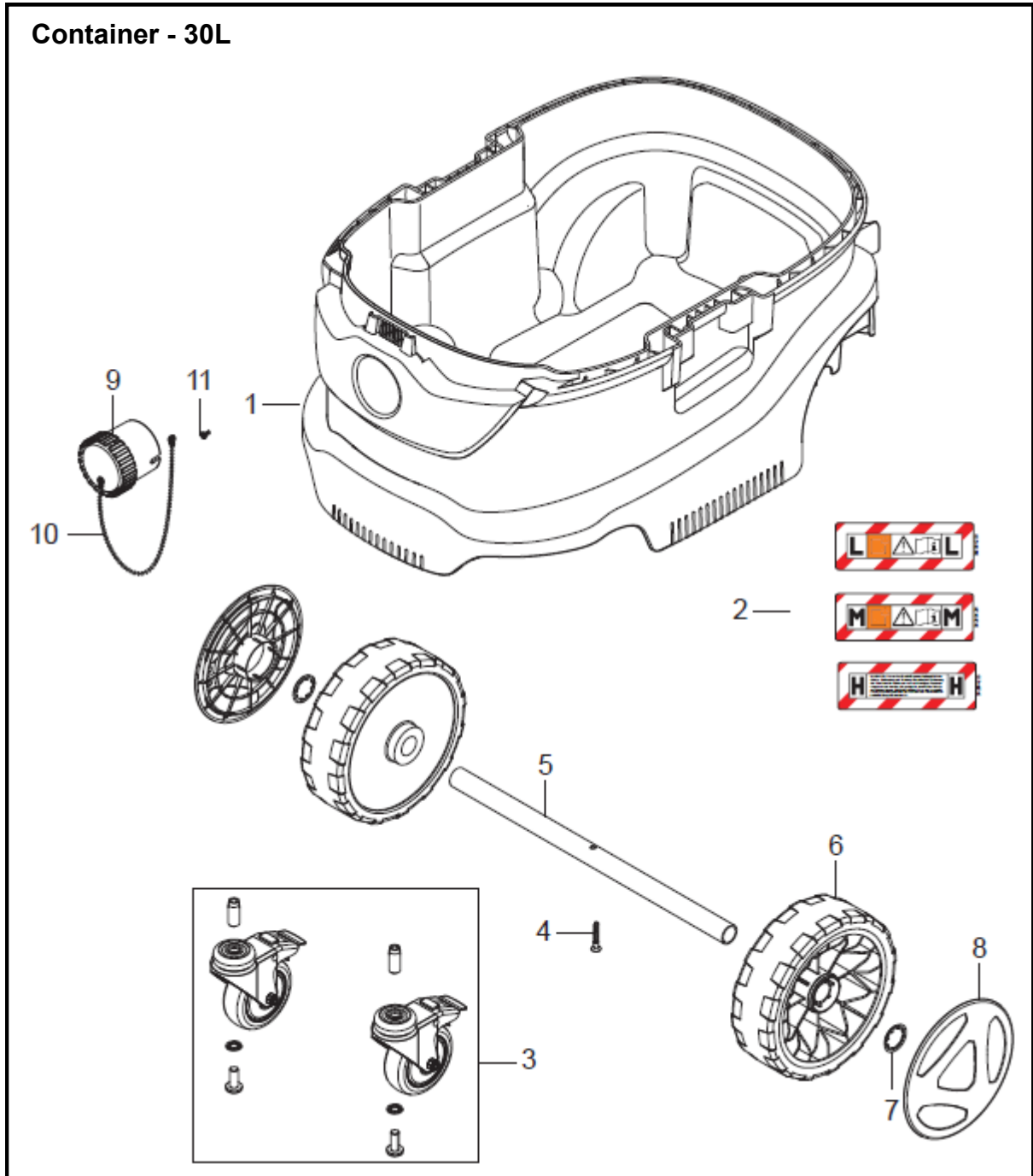
Container - 30L

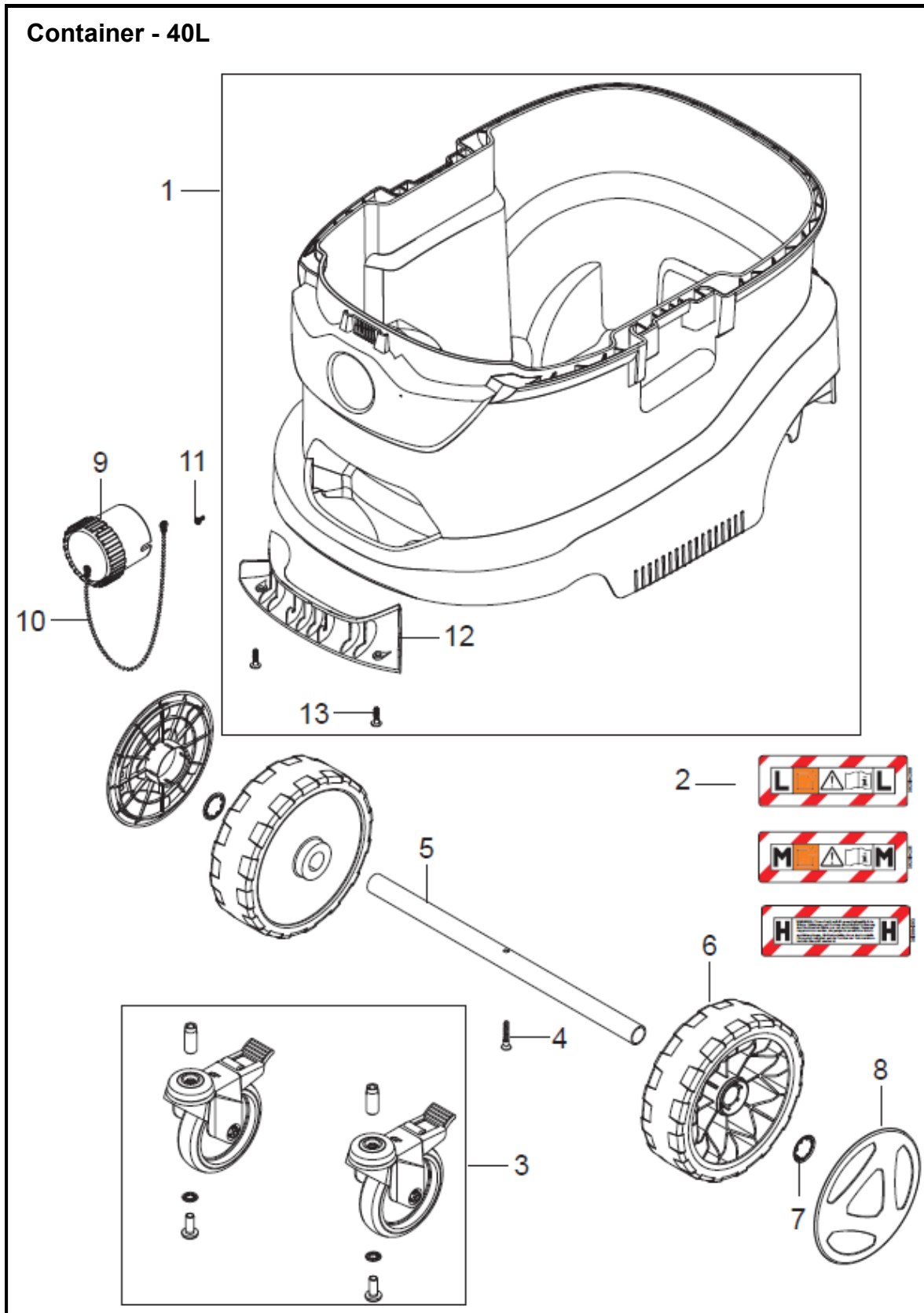

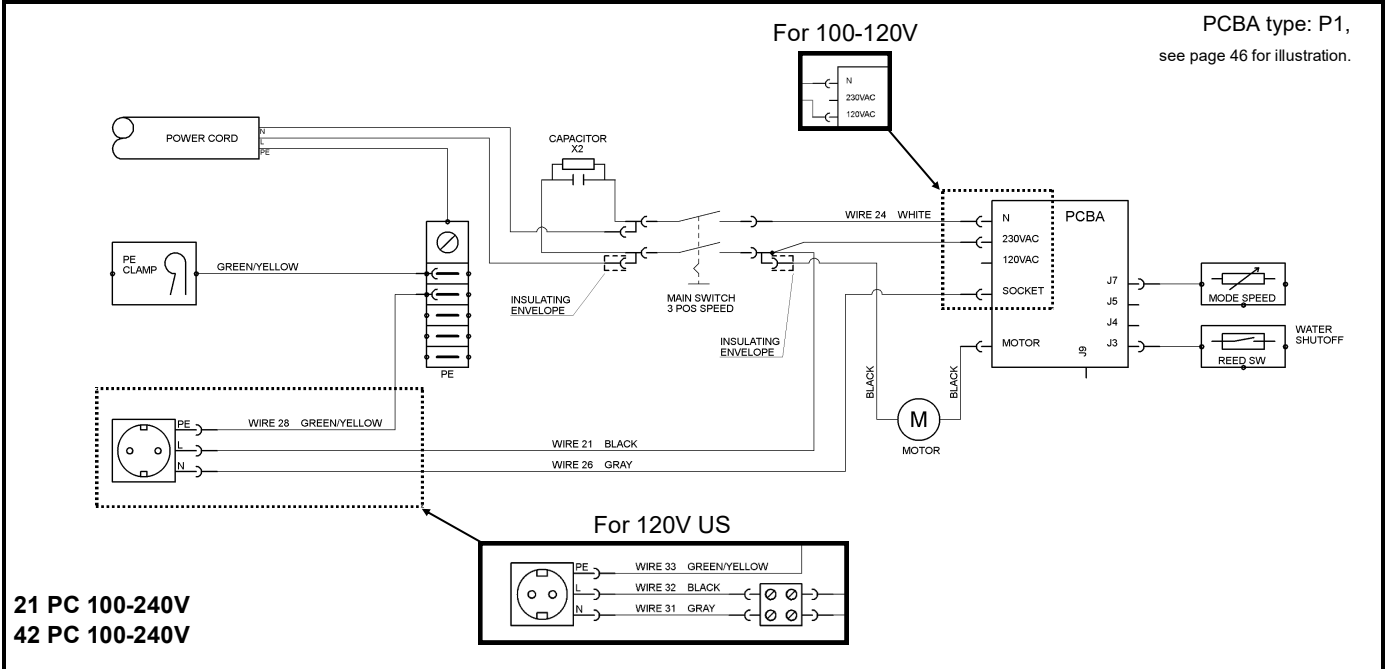
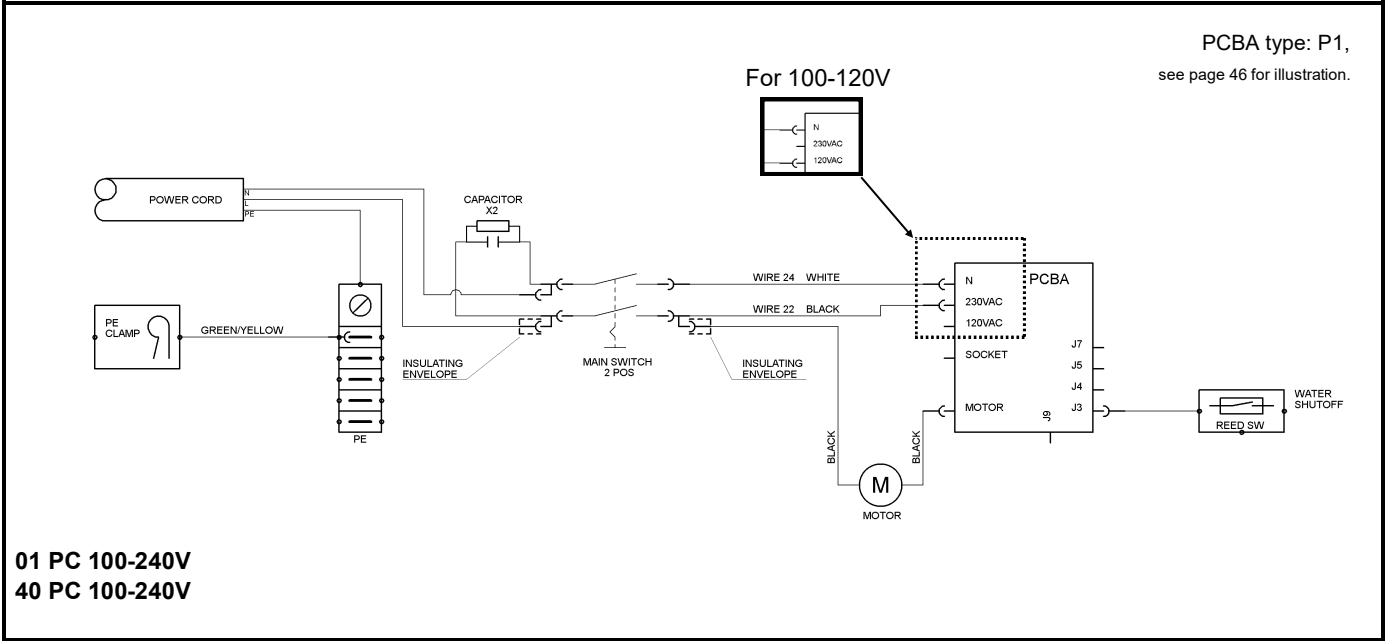
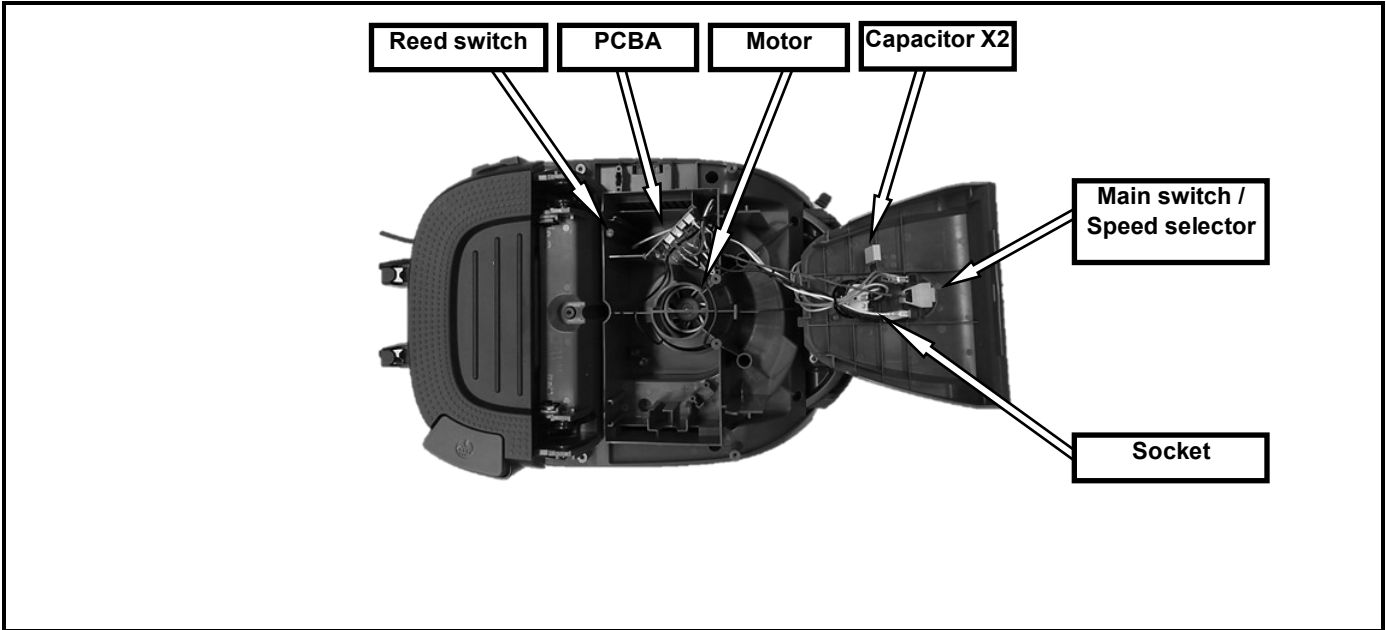

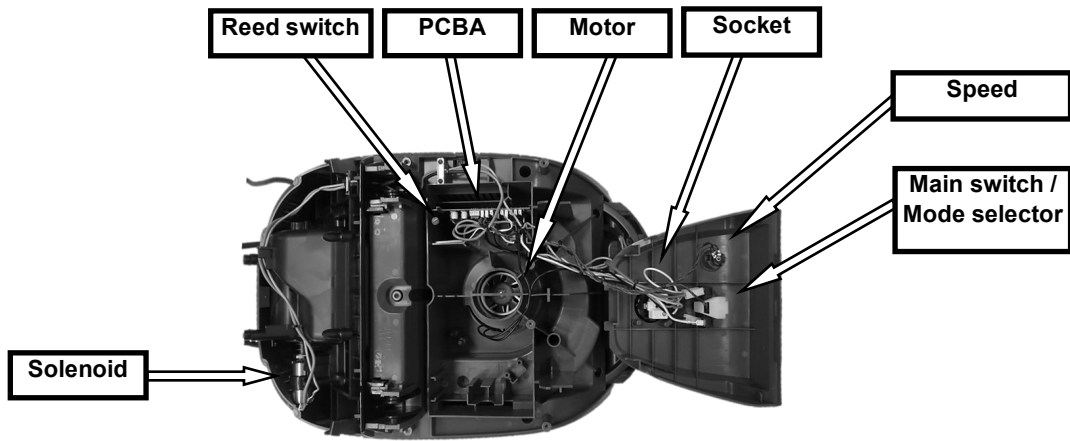



Work instruction 107417862

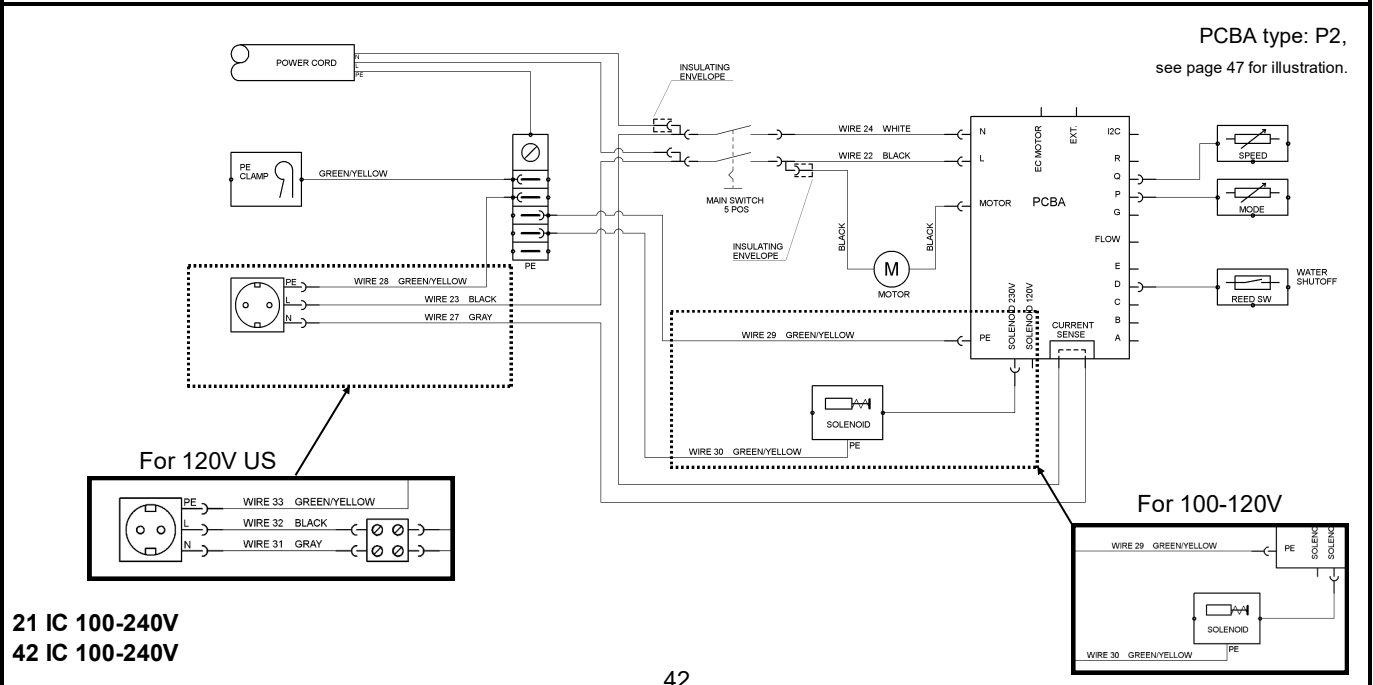
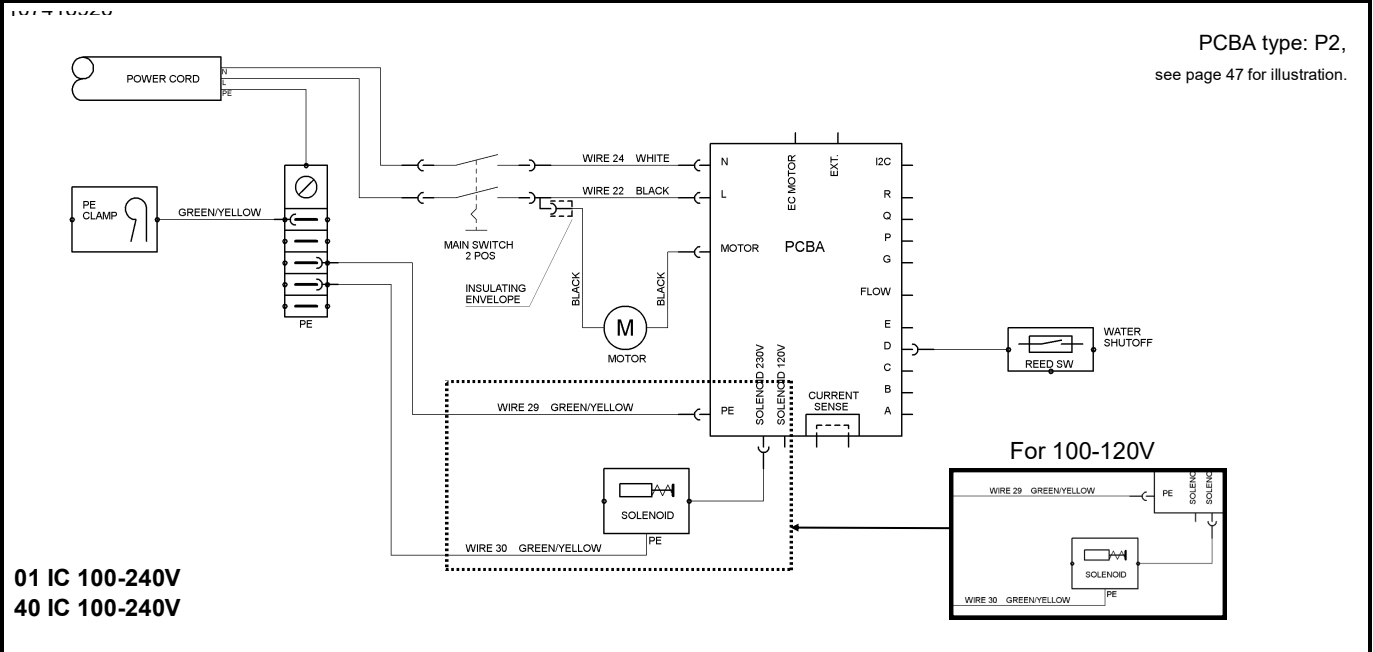

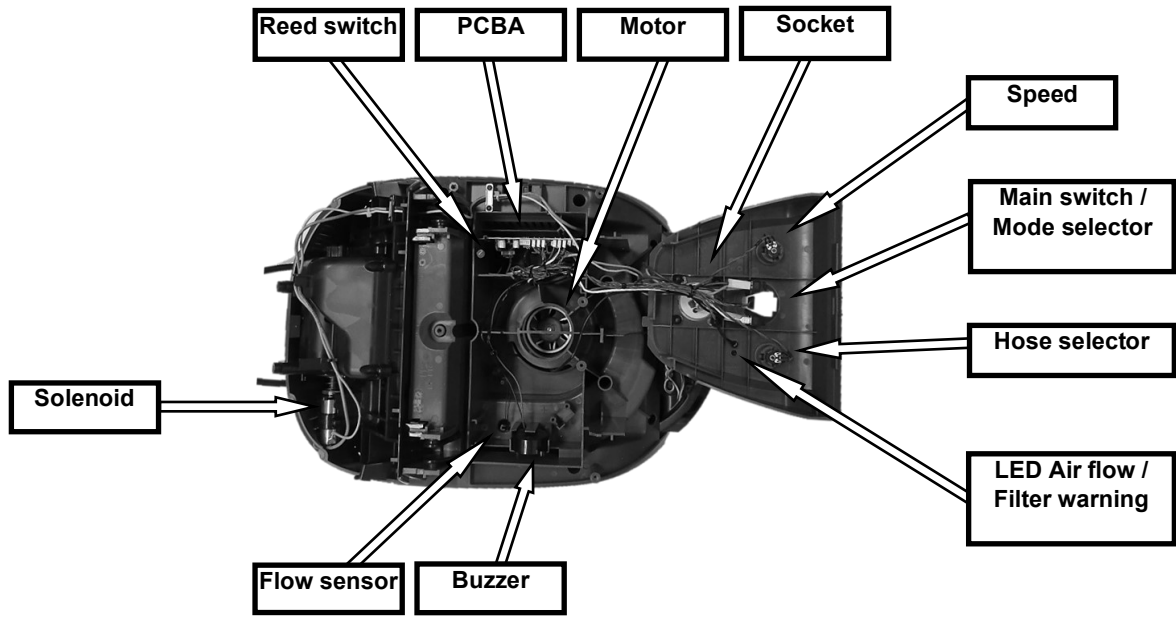

Work instruction 107417862

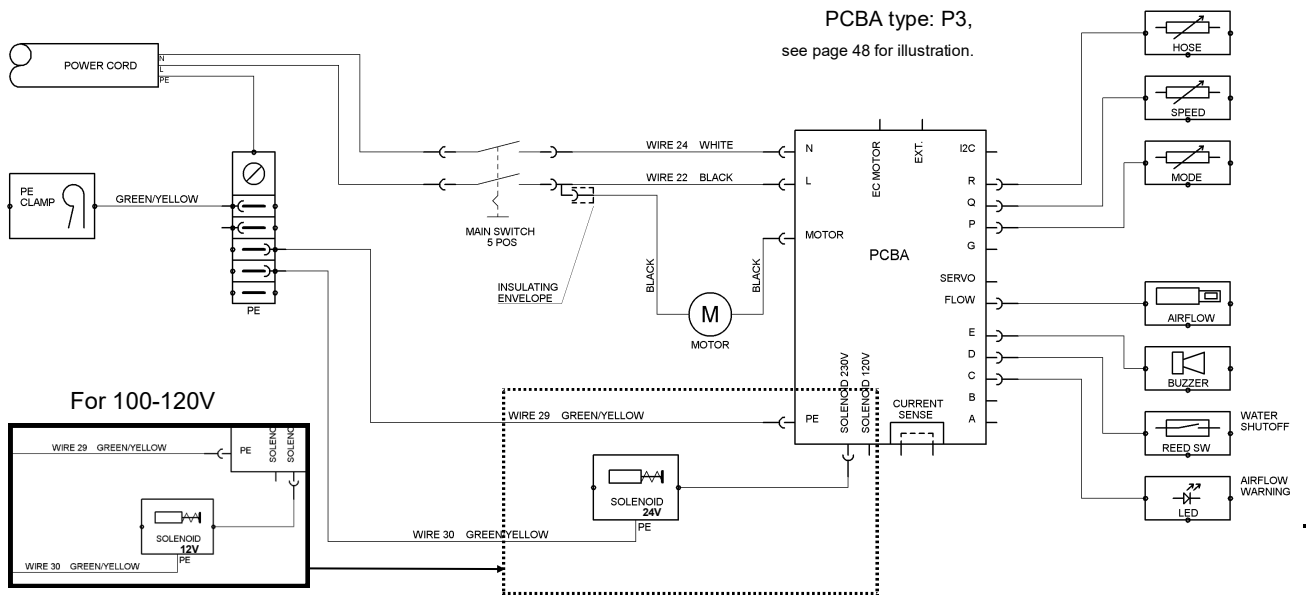

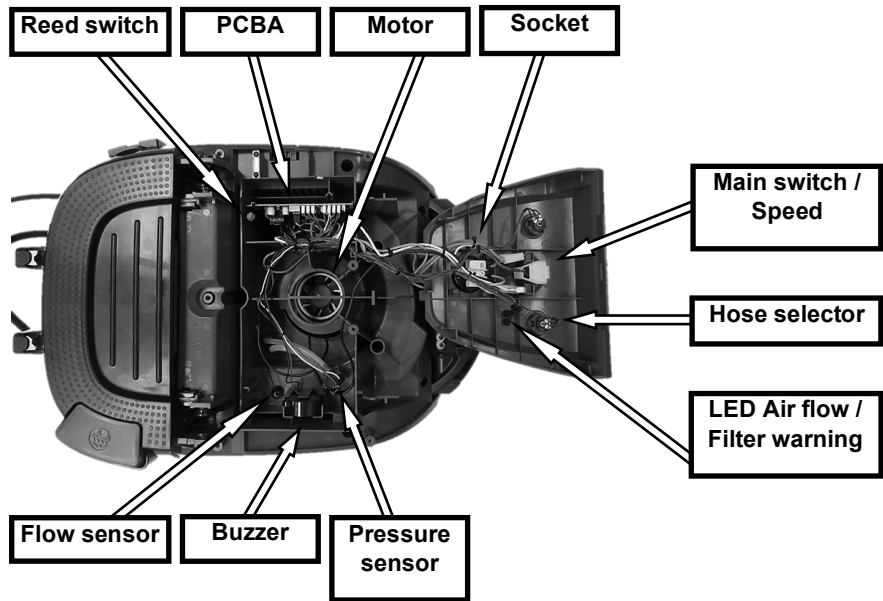

Work instruction 107417862

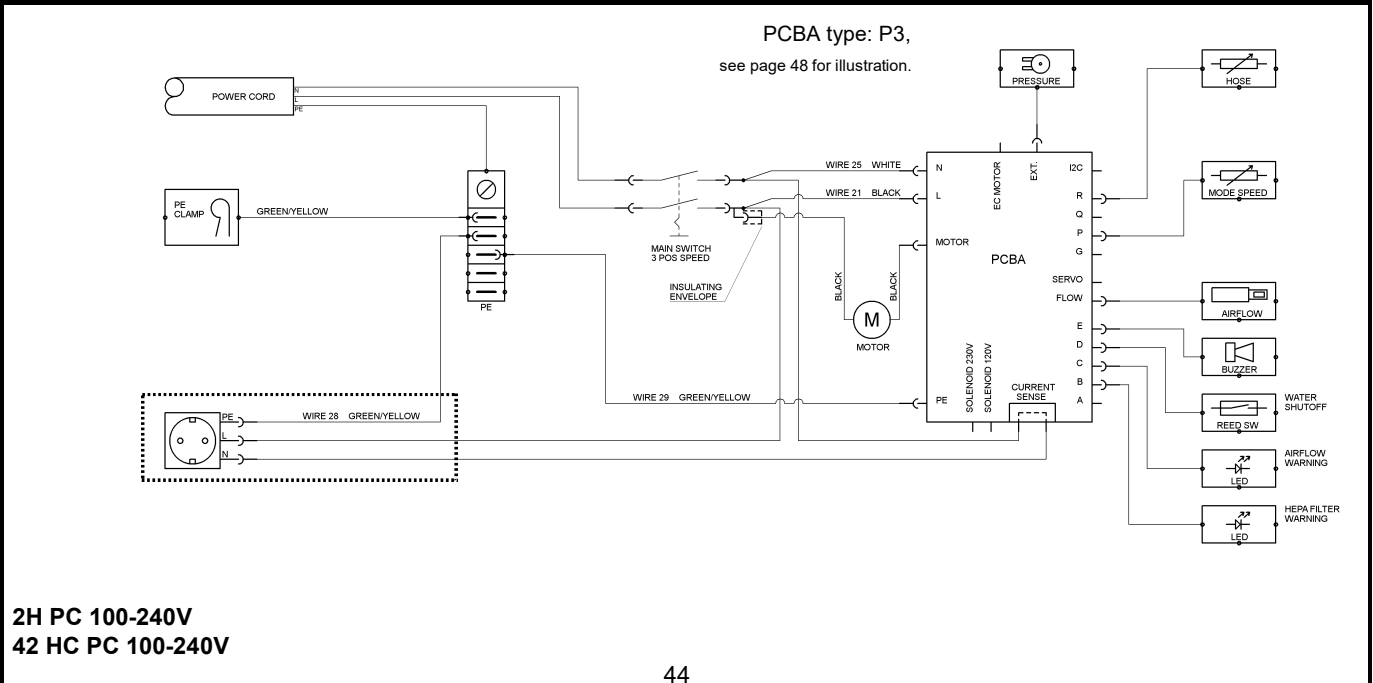
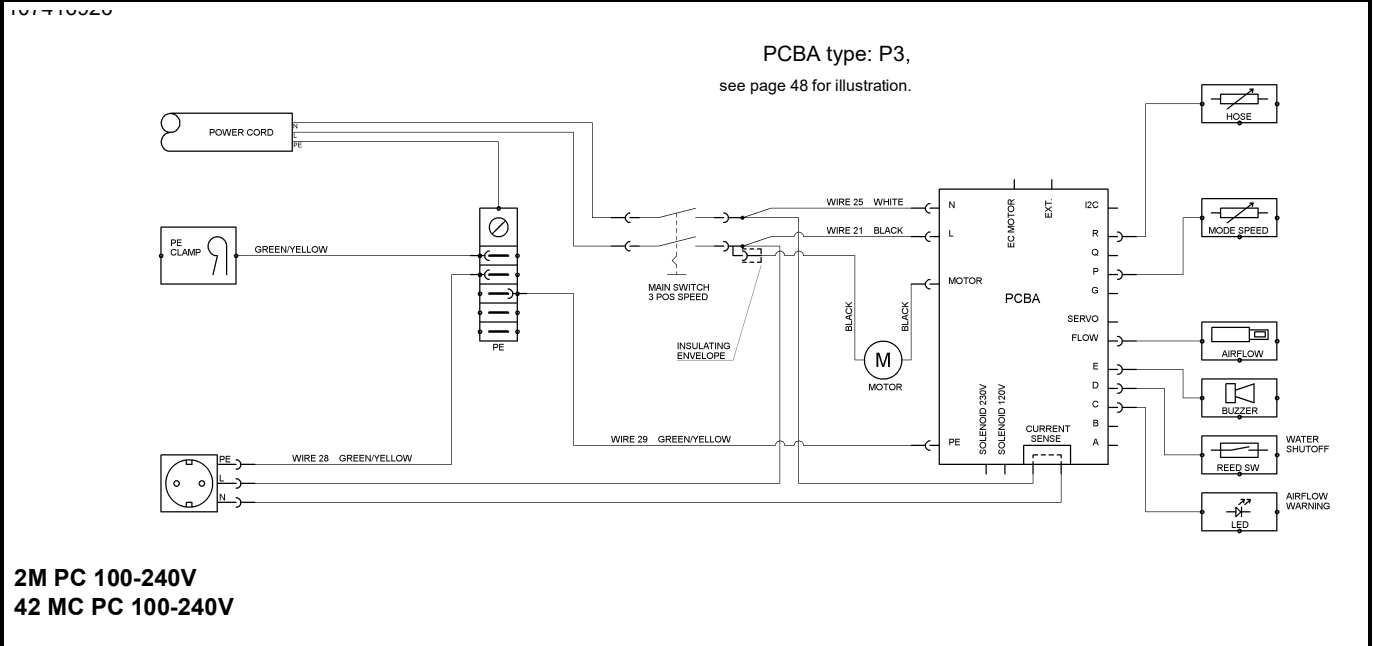

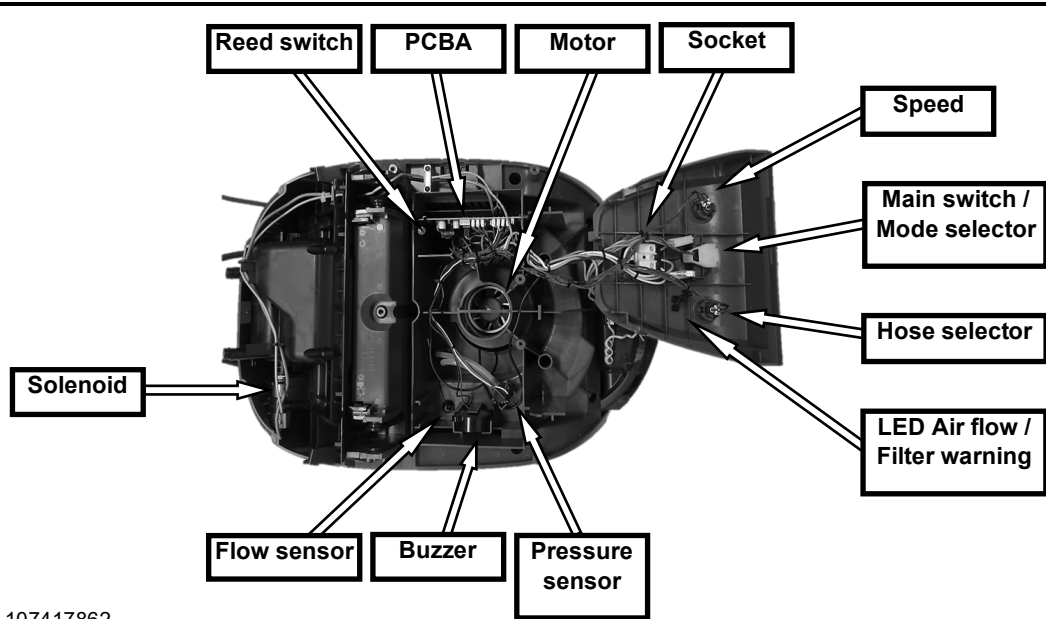

Work instruction 107417862

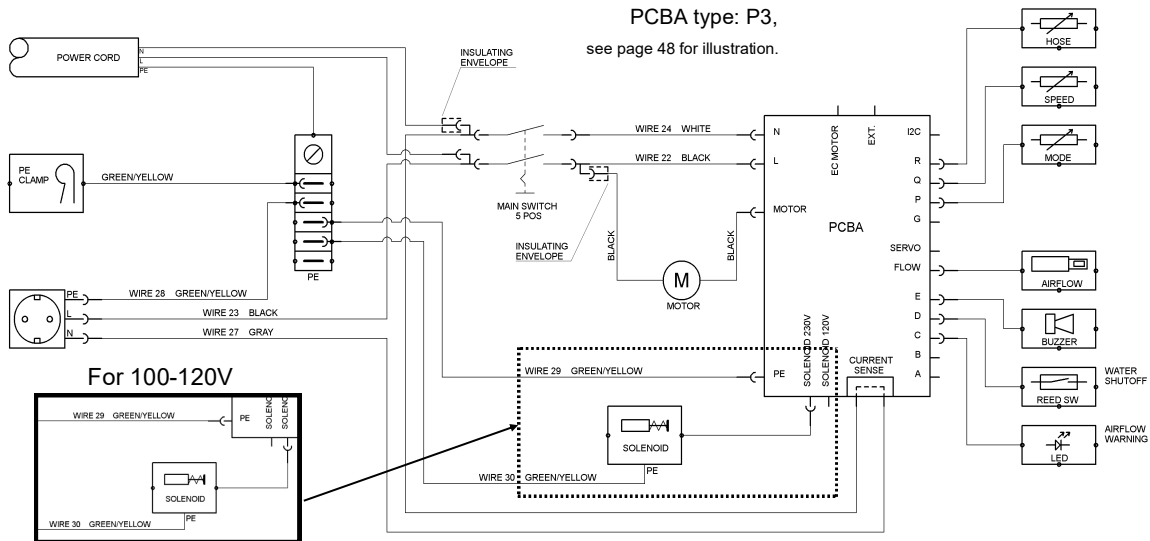

2M IC 100-240V
42 HC IC 100-240V

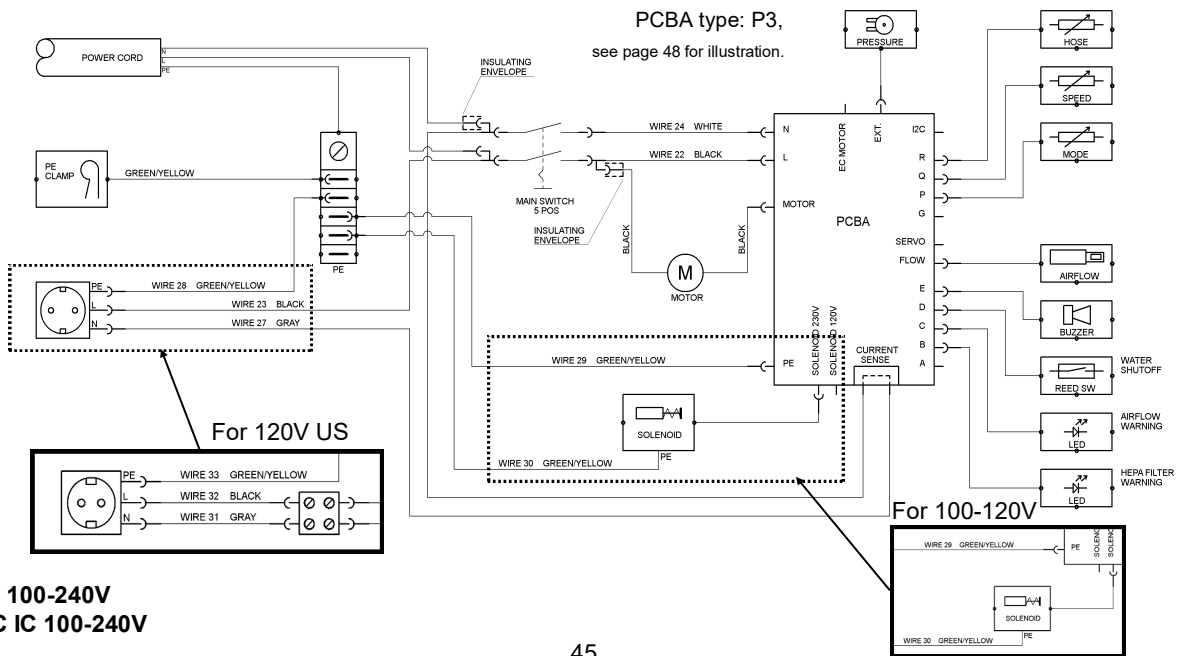

2H IC 100-240V
42 HC IC 100-240V

PCBA TYPE P1

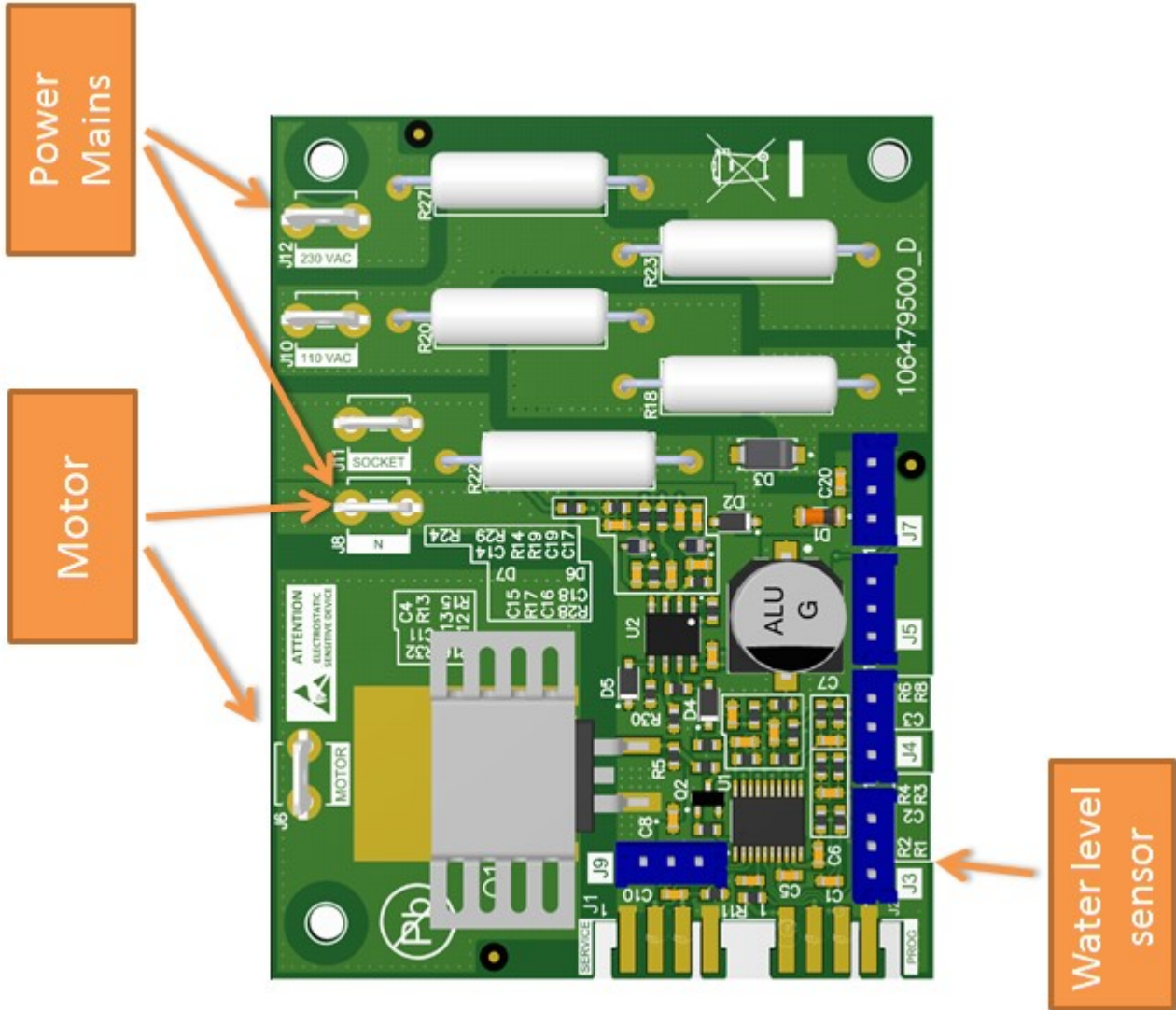

PCBA TYPE P2

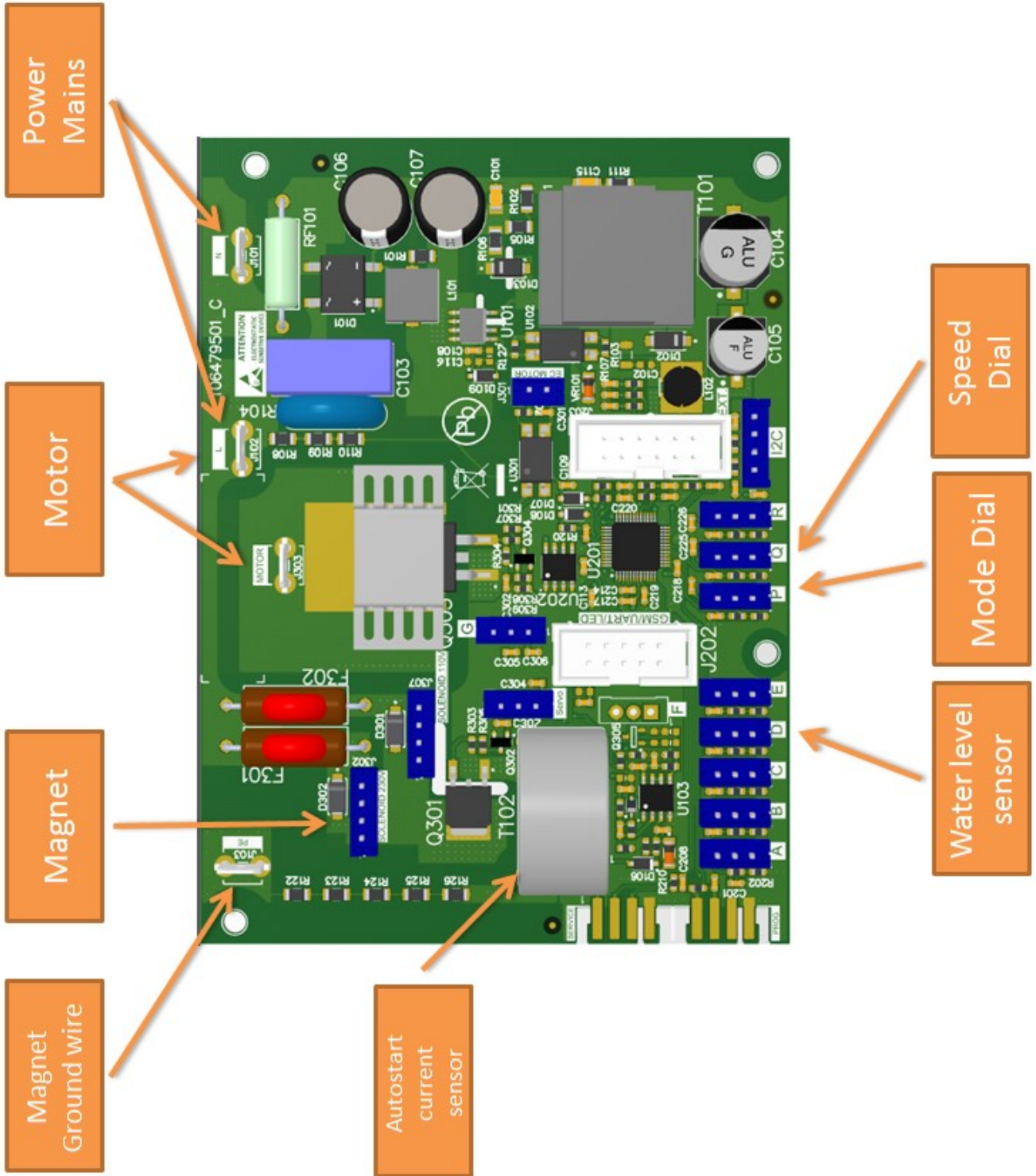

PCBA TYPE P3

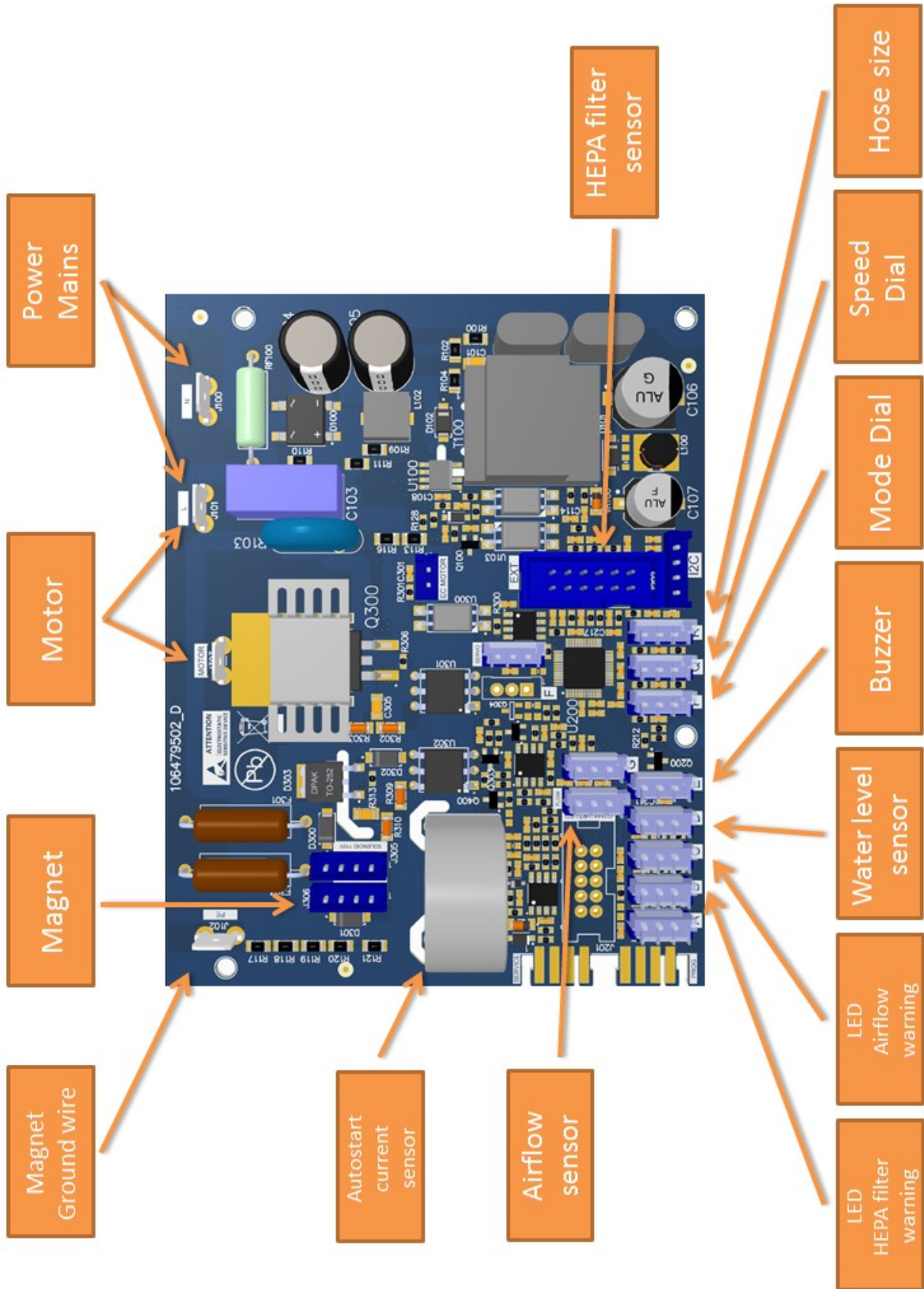

Wire overview

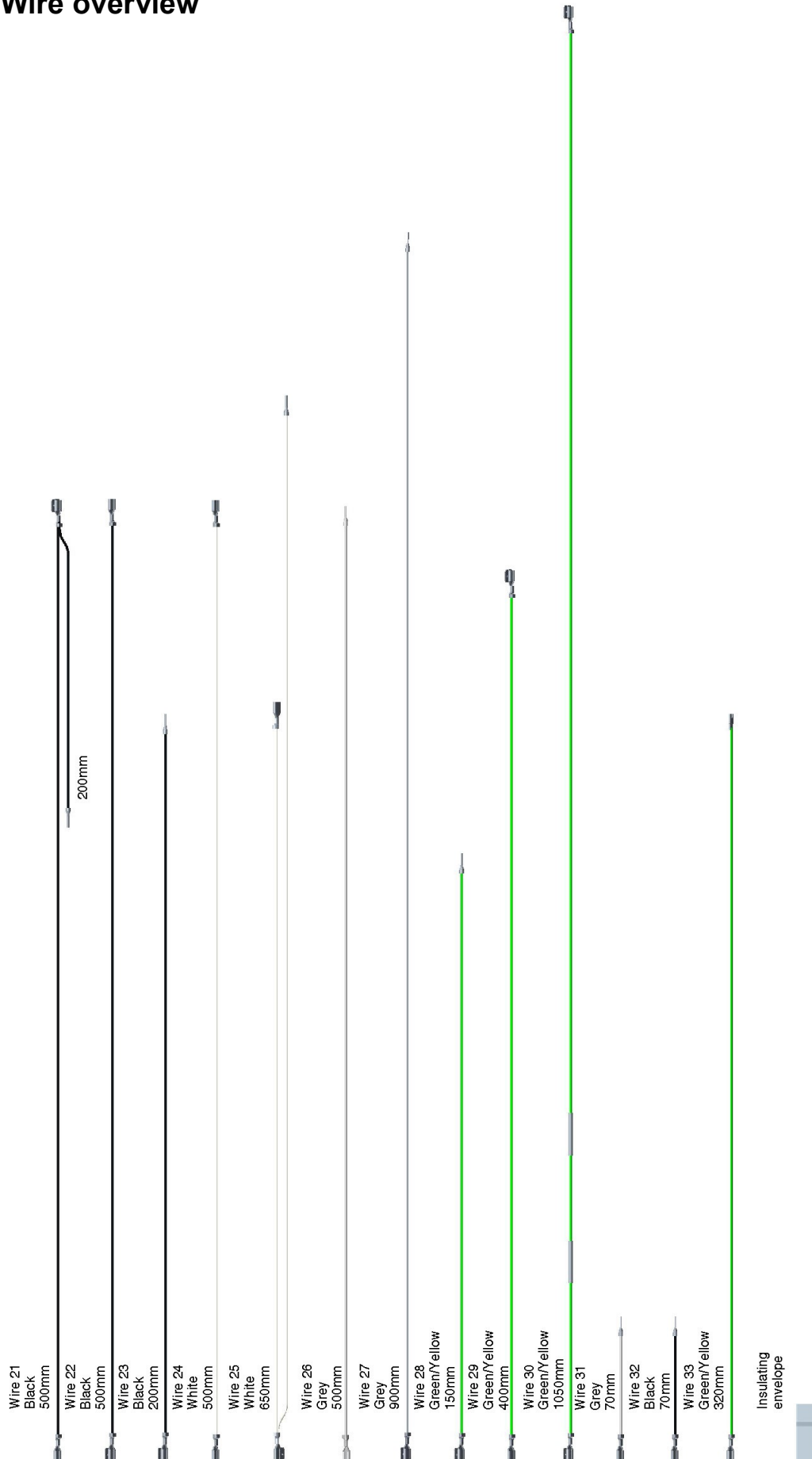

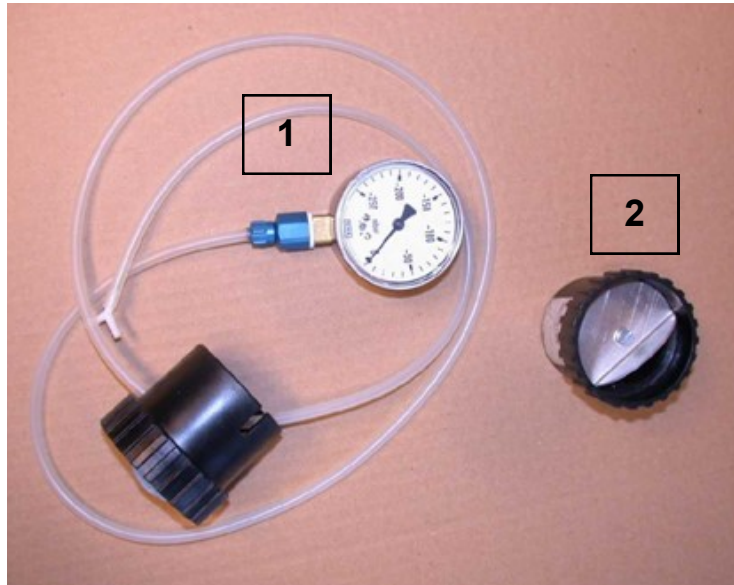

1. Manometer setting tool **P/N 40434**
2. Air restrictor setting tool **P/N 62480**
3. Callibration switch **P/N 107416579**

