

CE 08/2013
(1)
1465366000

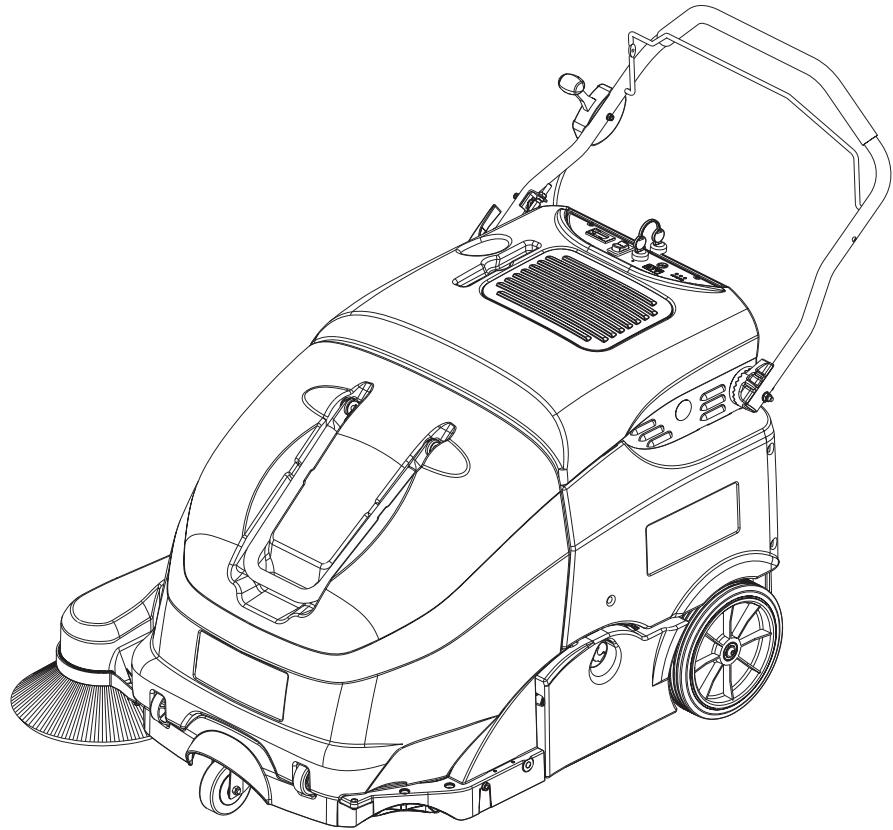

ENGLISH



Model: 9084110010



USER MANUAL
TRANSLATION OF ORIGINAL
INSTRUCTION

SW900

USER MANUAL



Сертификат за съответствие
Osvědčení o shodě
Konformitätserklärung
Overensstemmelsescertifikat
Declaración de conformidad
Vastavussertifikaat
Déclaration de conformité
Yhdenmukaisuustodistus

Conformity certificate
Πιστοποιητικό συμμόρφωσης
Megfelelősségi nyilatkozat
Dichiarazione di conformità
Atitikties deklaracija
Atbilstības deklarācija
Konformitetscertificering
Conformiteitsverklaring

Declaração de conformidade
Deklaracja zgodności
Certificat de conformitate
Заявление о соответствии
Överensstämmelsecertifikat
Certifikát súladu
Certifikat o ustreznosti
Uyumluluk sertifikası

Модел / Model / Modell / Model / Modelo / Mudel / Modèle / Malli /
Model / Μοντέλο / Modell / Modello / Modelis / Modelis / Modell / Model
/ Modelo / Model / Model / Модель / Modell / Model / Model / Model :

SWEEPER

Тип / Typ / Typ / Type / Tipo / Tüüp / Type / Tyypit / Type / Τύπος /
Típus / Tipo / Tipas / Tips / Type / Type / Tipo / Typ / Tip / Тип / Typ /
Typ / Tip / Tip :

SW900

Сериен номер / Výrobní číslo / Seriennummer / Seriennummer / Número de serie / Seerianumber / Numéro de série / Sarjanumero / Serial number
/ Σειριακός αριθμός / Sorozatszám / Numero di serie / Serijos numeris / Sērijas numurs / Seriennummer / Seriennummer / Número de série / Numer
seryjny / Număr de serie / Серийный номер / Seriennummer / Výrobné číslo / Serijska številka / Seri Numarası :

Година на производство / Rok výroby / Baujahr / Fabrikationsår / Año de fabricación / Vajjalaskeaasta / Année de fabrication / Valmistusvuosi / Year
of construction / Έτος κατασκευής / Gyártási év / Anno di costruzione / Pagaminimo metai / Izgatavošanas gads / Byggeår / Baujaar / Ano de fabrico
/ Rok produkcji / Anul fabricației / Год выпуска / Tillverkningsår / Rok výroby / Leto izdelave / Leto izdelave/İmal yılı :

BG Долоуподписаният потвърждава, че гореспоменатият модел е произведен в съответствие със следните директиви и стандарти. Техническият файл е съставен от производителя.

GB The undersigned certify that the above mentioned model is produced in accordance with the following directives and standards. The technical file is compiled by the manufacturer.

P A presente assinatura serve para declarar que os modelos supramencionados são produtos em conformidade com as seguintes directivas e normas. A ficha técnica é redigida pelo fabricante.

CZ Niže podepsaný stvrzuje, že výše uvedený model byl vyroben v souladu s následujícími směrnici a normami. Autorem technického listu je výrobce.

GR Ο κάτωθι υπογεγραμμένος πιστοποιεί ότι η παραγωγή του προαναφερθέντος μοντέλου γίνεται σύμφωνα με τις ακόλουθες οδηγίες και πρότυπα. Το τεχνικό αρχείο συντάσσεται από τον κατασκευαστή.

PL Niżej podpisany zaświadcza, że wymieniony powyżej model produkowany jest zgodnie z następującymi dyrektywami i normami. Dokumenty techniczne zostały przygotowane przez producenta.

D Der Unterzeichner bestätigt hiermit dass die oben erwähnten Modelle gemäß den folgenden Richtlinien und Normen hergestellt wurden. Die technische Dokumentation wird vom Hersteller erstellt.

H Alulírottak igazoljuk, hogy a fent említett modellt a köveitkező irányelvek és szabványok alapján hoztuk létre. A műszaki fájlt a gyártó készítette.

RO Subsemnatul atest că modelul sus-menționat este produs în conformitate cu următoarele directive și standarde. Fișierul tehnic este redactat de către producător.

DK Undertegnede attesterer herved, at ovennævnte model er produceret i overensstemmelse med følgende direktiver og standarder. Den tekniske fil er udarbejdet af fabrikanten.

I Il sottoscritto dichiara che i modelli sopra menzionati sono prodotti in accordo con le seguenti direttive e standard. Il fascicolo tecnico è redatto dal costruttore.

RUS Настоящим удостоверяется, что машина вышеуказанной модели изготовлена в соответствии со следующими директивами и стандартами. Техническая документация составлена производителем.

E El abajo firmante certifica que los modelos arriba mencionados han sido producidos de acuerdo con las siguientes directivas y estándares. El fascículo técnico está redactado por el fabricante

LT Toliau pateiktu dokumentu patvirtinama, kad minėtas modelis yra pagamintas laikantis nurodytų direktyvų bei standartų. Techninę bylą sudarė gamintojas.

S Undertecknad intygar att ovannämnda modell är producerad i överensstämmelse med följande direktiv och standarder. Den tekniska filen är sammanställd av tillverkaren.

EST Allakirjutanu kinnitab, et ülalnimetatud mudel on valmistatud kooskõlas järgmiste direktiivide ja normidega. Tehnilise dokumentatsiooni koostab tootja.

LV Ar šo tiek apliecināts, ka augstākminētais modelis ir izgatavots atbilstoši šādām direktīvām un standartiem. Tehnisko aprakstu ir sastādījis ražotājs.

SK Dolu podpísaný osvedčuje, že hore uvedený model sa vyrába v súlade s nasledujúcimi smernicami a normami. Technický súbor vytvoril výrobca.

F Je soussigné certifie que les modèles ci-dessus sont fabriqués conformément aux directives et normes suivantes. Le dossier technique est rédigé par le fabricant.

N Undertegnede attesterer att ovennævnte modell är produceret i överensstemmelse med följande direktiv och standarder. Den tekniske filen er opprettet av produsenten.

SLO Spodaj podpisani potrjujem, da je zgoraj omenjeni model izdelan v skladu z naslednjimi smernicami in standardi. Spis s tehnično dokumentacijo pripravi izdelovalec.

FIN Allekirjoittain vakuuttaa että yllämainittu malli on tuotettu seuraavien direktiivien ja standardien mukaan. Valmistaja kääntää teknisen tiedoston.

NL Ondergetekende verzekert dat de bovengenoemde modellen geproduceerd zijn in overeenstemming met de volgende richtlijnen en standaards. Het technische bestand is door de fabrikant samengesteld.

TR Aşağıda İmzası olan kişi, yukarıda bahsedilen model cihazın aşağıda verilen direktiflere ve standartlara uygunlukta imal edildiğini onaylar. Teknik dosya üretici tarafından derlenmiştir.

EC Machinery Directive 2006/42/EC

EN ISO 12100, EN ISO 13857, EN 349, EN 982

EC Low Voltage Directive 2006/95/EC

EN 60335-1, EN 60335-2-72, EN 50366

EC EMC Directive 2004/108/EC

EN 55022, EN 55014-2, EN 61000-6-2

Производителя / Výrobce / Hersteller / Fabrikanten /
Fabricante / Tootja / Fabricant / Valmistaja / Manufacturer
/ Κατασκευαστή / Gyártó / Costruttore / Gamintojas /
Ražotājs / Produsenten / Fabrikant / Fabricante / Producenta
/ Producător / Производителем / Tillverkaren / Výrobca /
Izdelovalec / Üretici :

Nilfisk-Advance S.p.A.

Strada Comunale della Braglia, 18 - 26862 - GUARDAMIGLIO (LO) - ITALY

Tel: +39 (0)377 451124, Fax: +39 (0)377 51443

Authorized signatory: Sergio Coccapani, R&D Manager

Date:

Signature:

TABLE OF CONTENTS

INTRODUCTION	2
MANUAL PURPOSE AND CONTENTS	2
TARGET.....	2
HOW TO KEEP THIS MANUAL.....	2
DECLARATION OF CONFORMITY	2
IDENTIFICATION DATA.....	2
OTHER REFERENCE MANUALS.....	2
SPARE PARTS AND MAINTENANCE.....	2
CHANGES AND IMPROVEMENTS	2
OPERATION CAPABILITIES	3
CONVENTIONS	3
UNPACKING/DELIVERY	3
SAFETY	3
VISIBLE SYMBOLS ON THE MACHINE.....	3
SYMBOLS THAT APPEAR ON THIS MANUAL.....	4
GENERAL INSTRUCTIONS.....	4
MACHINE DESCRIPTION	6
MACHINE STRUCTURE	6
ACCESSORIES/OPTIONS.....	8
TECHNICAL DATA.....	8
WIRING DIAGRAM.....	9
USE	10
BATTERY CHECK/SETTING ON A NEW MACHINE	11
BEFORE MACHINE START-UP	12
STARTING AND STOPPING THE MACHINE	12
MACHINE OPERATION	12
HOPPER DUMPING.....	13
AFTER USING THE MACHINE.....	13
PUSHING THE MACHINE.....	13
MACHINE LONG INACTIVITY	13
MAINTENANCE	13
SCHEDULED MAINTENANCE TABLE	14
BATTERY CHARGER CABLE CHECK	14
BATTERY CHARGING	14
MAIN BROOM HEIGHT CHECK AND ADJUSTMENT	15
MAIN BROOM REPLACEMENT	16
SIDE BROOM HEIGHT CHECK AND ADJUSTMENT	17
SIDE BROOM DISASSEMBLY/ASSEMBLY.....	17
SKIRT CHECK AND ADJUSTMENT	18
DUST FILTER CLEANING AND INTEGRITY CHECK	19
HOPPER POSITION MICROSWITCH OPERATION CHECK.....	20
FUSE CHECK/REPLACEMENT/RESET.....	20
BATTERY ELECTROLYTE LEVEL CHECK (FOR WET BATTERIES ONLY).....	20
TROUBLESHOOTING	21
SCRAPPING	22

INTRODUCTION



NOTE

The numbers in brackets refer to the components shown in Machine Description chapter.

MANUAL PURPOSE AND CONTENTS

The purpose of this Manual is to provide the operator with all necessary information to use the machine properly, in a safe and autonomous way. It contains information about technical data, safety, operation, storage, maintenance, spare parts and disposal. Before performing any procedure on the machine, the operators and qualified technicians must read this Manual carefully. Contact Nilfisk in case of doubts concerning the interpretation of the instructions and for any further information.

TARGET

This Manual is intended for operators and technicians qualified to perform the machine maintenance.

The operators must not perform procedures reserved for qualified technicians. Nilfisk will not be responsible for damages coming from failure to follow these instructions.

HOW TO KEEP THIS MANUAL

The User Manual must be kept near the machine, inside an adequate case, away from liquids and other substances that can cause damage to it.

DECLARATION OF CONFORMITY

The Declaration of Conformity, supplied with the machine, certifies the machine conformity with the law in force.



NOTE

Two copies of the original declaration of conformity are provided together with the machine documentation.

IDENTIFICATION DATA

The machine serial number and model name are marked on the plate (47).

Product code and year of production are marked on the same plate.

This information is useful when requiring machine spare parts. Use the following table to write down the machine identification data.

MACHINE model
PRODUCT code
MACHINE serial number

OTHER REFERENCE MANUALS

- Electronic Battery Charger Manual (to be considered as integral part of this Manual)
- Spare Parts List (supplied with the machine)

Moreover, the following Manuals are available:

- Service Manual (that can be consulted at Nilfisk Service Centers)

SPARE PARTS AND MAINTENANCE

All necessary operating, maintenance and repair procedures must be performed by qualified personnel or by Nilfisk Service Centers. Only original spare parts and accessories must be used.

Contact Nilfisk for service or to order spare parts and accessories, specifying the machine model, product code and serial number.

CHANGES AND IMPROVEMENTS

Nilfisk constantly improves its products and reserves the right to make changes and improvements at its discretion without being obliged to apply such benefits to the machines that were previously sold.

Any change and/or addition of accessory must be approved and performed by Nilfisk.

OPERATION CAPABILITIES

This sweeper has been designed to clean (by sweeping and vacuuming) smooth and solid floors, and to collect dust and light debris, in civil and industrial environments, under safe operation conditions by a qualified operator.

CONVENTIONS

Forward, backward, front, rear, left or right are intended with reference to the operator's position, that is to say with the hands on the handlebar (10).

UNPACKING/DELIVERY



CAUTION!

To unpack the machine, carefully follow the instructions on the packing.

Upon delivery carefully check that the machine and its packing have not been damaged during transportation. In case of visible damages, keep the packing and have it checked by the carrier that delivered it. Call the carrier immediately to fill in a damage claim. Check that the machine is equipped with the following features:

- Technical documents:
 - Sweeper User Manual (the present document)
 - Electronic Battery Charger Manual
 - Sweeper Spare Parts List
- No. 1 5 A fuse

SAFETY

The following symbols indicate potentially dangerous situations. Always read this information carefully and take all necessary precautions to safeguard people and property.

The operator's cooperation is essential in order to prevent injury. No accident prevention program is effective without the total cooperation of the person responsible for the machine operation. Most of the accidents that may occur in a factory, while working or moving around, are caused by failure to comply with the simplest rules for exercising prudence. A careful and prudent operator is the best guarantee against accidents and is essential for successful completion of any prevention program.

VISIBLE SYMBOLS ON THE MACHINE

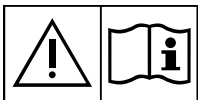

WARNING!

Carefully read all the instructions before performing any operation on the machine.



WARNING!

Do not wash the machine with direct or pressurised water jets.



WARNING!

Do not use the machine on slopes with a gradient exceeding the specifications.

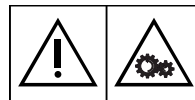

WARNING!

Moving parts.

SYMBOLS THAT APPEAR ON THIS MANUAL



DANGER!

It indicates a dangerous situation with risk of death for the operator.



NOTE

It indicates a remark related to important or useful functions.



WARNING!

It indicates a potential risk of injury for people or damage to objects.



CONSULTATION

It indicates the necessity to refer to the User Manual before performing any procedure.



CAUTION!

It indicates a caution or a remark related to important or useful functions. Pay careful attention to the paragraphs marked by this symbol.

GENERAL INSTRUCTIONS

Specific warnings and cautions to inform about potential damages to people and machine are shown below.



DANGER!

- *Before performing any cleaning, maintenance, repair or replacement procedure, remove the ignition key.*
- *This machine must be used by properly trained operators only.*
- *Do not wear jewels when working near electrical components.*
- *Do not work under the lifted machine without supporting it with safety stands.*
- *Do not operate the machine near toxic, dangerous, flammable and/or explosive powders, liquids or vapours: This machine is not suitable for collecting dangerous powders.*
- *Keep the batteries away from sparks, flames and incandescent material. Explosive gases are released when charging the batteries.*
- *If the machine is equipped with lead (WET) batteries, battery charging produces highly explosive hydrogen gas. Charge the batteries in well-ventilated areas and away from naked flames.*
- *When lead batteries (WET) are installed, do not tilt the machine for more than 30° from the horizontal plane to prevent the highly corrosive acid from leaking out of the batteries. When the machine is to be tilted to perform maintenance procedures, remove the batteries.*



WARNING!

- *Carefully read all the instructions before performing any maintenance/repair procedure.*
- *Before using the battery charger, ensure that frequency and voltage values, indicated on the machine serial number plate, match the electrical mains voltage.*
- *Do not pull or carry the machine by the battery charger cable and never use the battery charger cable as a handle. Do not close a door on the battery charger cable, or pull the battery charger cable around sharp edges or corners. Do not run the machine on the battery charger cable.*
- *Keep the battery charger cable away from heated surfaces.*
- *Do not use the machine if the battery charger cable or plug is damaged. If the machine is not working as it should, has been damaged, left outdoors or dropped into water, return it to the Service Center.*
- *Before performing any maintenance procedure, disconnect the battery charger cable from the electrical mains to avoid any risk of fire, electric shock or injuries.*

**WARNING!**

- *Do not smoke while charging the batteries.*
- *This machine is not intended for use by persons (including children) with reduced physical, sensory or mental capabilities, or lack of experience and knowledge, unless they have been given supervision or instruction concerning use of the machine by a person responsible for their safety. Children should be supervised to ensure that they do not play with the machine.*
- *Close attention is necessary when used near children.*
- *Use only as shown in this Manual. Use only Nilfisk's recommended accessories.*
- *Check the machine carefully before each use, always check that all the components have been assembled before use. If the machine is not perfectly assembled it can cause damages to people and properties.*
- *Take all necessary precautions to prevent hair, jewels and loose clothes from being caught by the machine moving parts.*
- *To avoid any unauthorised use of the machine, remove the ignition key.*
- *Do not leave the machine unattended without being sure that it cannot move independently.*
- *Do not use the machine on slopes with a gradient exceeding the specifications.*
- *Do not tilt the machine more than the angle indicated on the machine itself, in order to prevent instability.*
- *Use only brooms supplied with the machine or those specified in the User Manual. Using other brooms could reduce safety.*
- *Before using the machine, close all doors and/or covers, as indicated in the User Manual.*
- *Do not wash the machine with direct or pressurised water jets, or with corrosive substances.*
- *Use the machine only where a proper lighting is provided.*
- *While using this machine, take care not to cause damage to people or objects.*
- *Do not bump into shelves or scaffoldings, especially where there is a risk of falling objects.*
- *Do not lean liquid containers on the machine, use the relevant can holder.*
- *The storage temperature must be between 0°C and +40°C.*
- *The machine working temperature must be between 0°C and +40°C.*
- *The humidity must be between 30% and 95%.*
- *Always protect the machine against the rain and bad weather, both under operation and inactivity condition. Store the machine indoors, in a dry place. This machine must be used in dry conditions, it must not be used or kept outdoors in wet conditions.*
- *Do not use the machine as a means of transport, or for pushing/towing.*
- *Do not allow the brooms to operate while the machine is stationary to avoid damaging the floor.*
- *The machine maximum capacity is 30 kg (the maximum weight of waste).*
- *In case of fire, use a powder fire extinguisher, not a water one.*
- *This machine cannot be used on roads or public streets.*
- *Do not tamper with the machine safety guards.*
- *Follow the routine maintenance procedures scrupulously.*
- *Do not allow any object to enter into the openings. Do not use the machine if the openings are clogged. Always keep the openings free from dust, hairs and any other foreign material which could reduce the air flow.*
- *Do not remove or modify the plates affixed to the machine.*
- *In case of machine malfunctions, ensure that these are not due to lack of maintenance. If necessary, request assistance from the authorised personnel or from an authorised Service Center.*
- *If parts must be replaced, require ORIGINAL spare parts from an Authorised Dealer or Retailer.*
- *To ensure machine proper and safe operation, the scheduled maintenance shown in the relevant chapter of this Manual, must be performed by the authorised personnel or by an authorised Service Center.*
- *The machine must be disposed of properly, because of the presence of toxic-harmful materials (batteries, oils, etc.), which are subject to standards that require disposal in special centres (see the Scrapping chapter).*

MACHINE DESCRIPTION

MACHINE STRUCTURE

- | | |
|---|---|
| 1. Control panel | 13. Left side broom lifting/lowering lever (optional) |
| 2. Ignition key: | 14. Hopper |
| • Position "0": The machine is off and all functions are disabled | 15. Hopper transport handle |
| • Position "1": The machine is on and all functions are enabled | 16. Hopper wheels |
| 3. Electrical filter shaker switch | 17. Front pivoting wheel |
| 4. Charged battery LED (green) | 18. Right side broom |
| 5. Semi-discharged battery LED (yellow) | 19. Left side broom (optional) |
| 6. Discharged battery LED (red) | 20. Rear driving wheels |
| 7. Hour counter | 21. Battery and main motor hood |
| 8. Drive control lever | 22. Front hood latch |
| 9. Drive system control adjuster | 23. Left door opening/closing knob |
| 10. Handlebar | 24. Front skirt |
| 11. Handlebar tilting adjusting lever | 25. Rear skirt |
| 12. Right side broom lifting/lowering lever | 26. Side skirts |

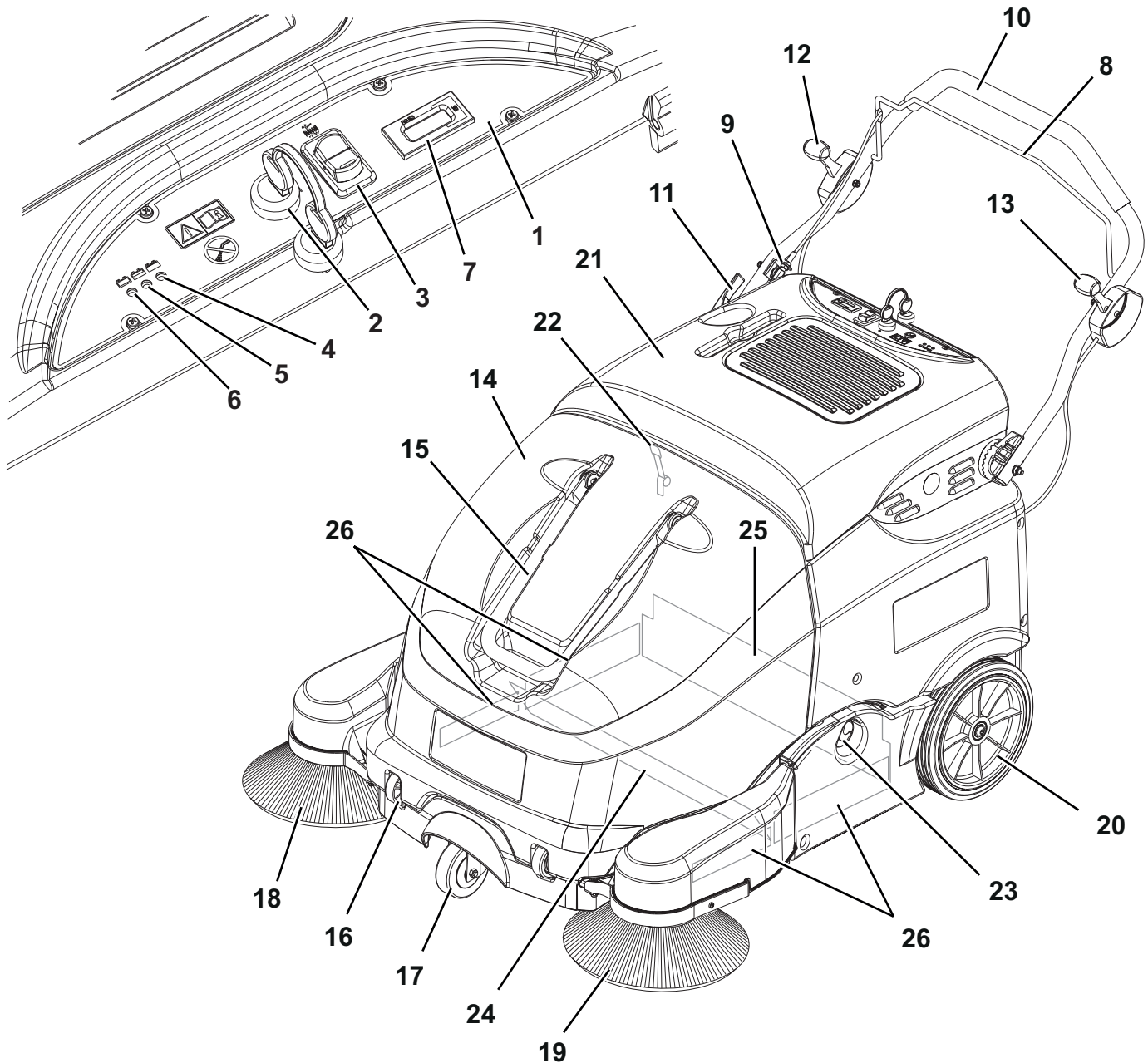

P100813

MACHINE STRUCTURE (Continues)

- 27. Main broom
- 28. Main broom height adjusting knob
- 29. Battery fuse
- 30. Filter shaker fuse
- 31. Battery charger fuse
- 32. Main motor circuit breaker
- 33. Right side broom motor circuit breaker
- 34. Left side broom motor circuit breaker (optional)
- 35. Batteries
- 36. Battery connector
- 37. Right door
- 38. Battery charger cable
- 39. Battery charger cable housing
- 40. Electronic battery charger
- 41. Dust filter
- 42. Pre-filter (optional)
- 43. "Wet by-pass" port
- 44. Main motor
- 45. Hopper position microswitch
- 46. Can holder
- 47. Serial number plate/technical data/conformity certification
- 48. Vacuum fan
- 49. Driving belt
- 50. Main broom belt
- 51. Rear grid

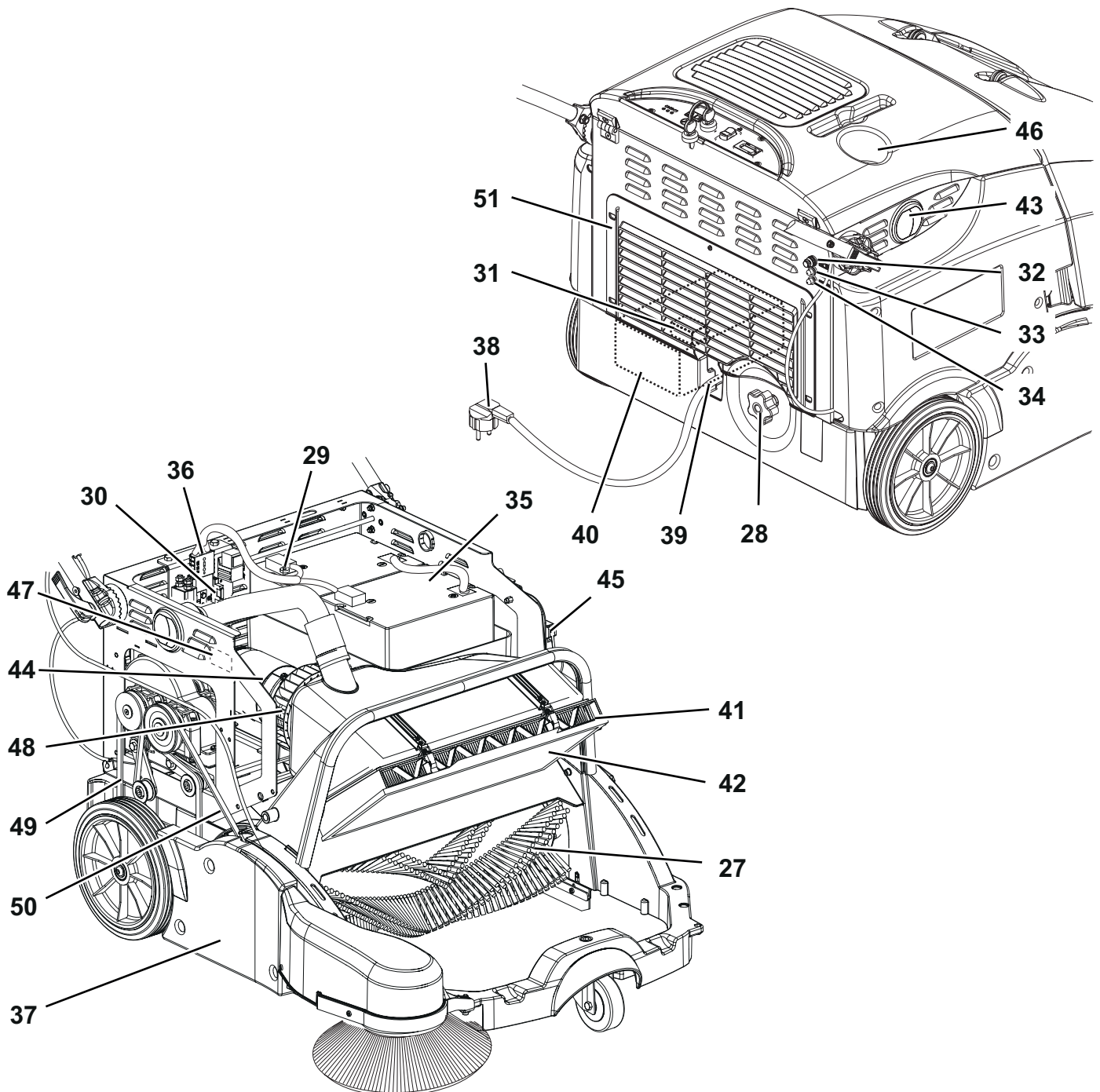

ACCESSORIES/OPTIONS

In addition to the standard components, the machine can be equipped with the following accessories/options, according to the machine specific use:

- Left side broom
- Main and side brooms with harder or softer bristles
- Paper dust filter
- Pre-filter
- Manual filter shaker
- Non-marking skirts

For further information concerning the optional accessories, contact an authorised Retailer.

TECHNICAL DATA

Model		SW900 B
Cleaning width	with one side broom	825 mm
	with two side brooms	1,050 mm
Main broom size (length x diameter)		600 x 265 mm
Side broom diameter		315 mm
Theoretical working capacity	with one side broom	3715 m ² /h
	with two side brooms	4725 m ² /h
Hopper	capacity	60 litres
	maximum transportable weight	30 kg
Filter	cleaning system	Electrical filter shaker
	area	1.9 m ²
	filtering capacity	5-10 µm
Power		12 Volt batteries
Main motor	power (drive/main broom/vacuum system)	680 W
Main broom	speed	420 rpm
Side broom	motor power	40 W
	speed	100 rpm
Drive	forward speed	4.5 km/h
Maximum gradient when working		2 %
Filter shaker motor		12 W
Total absorbed power		0.8 kW
Working autonomy		3 h
Size (length x width x height)	machine running	1,390 x 870 x 1,100 mm
	machine with folded handlebar	1,050 x 870 x 840 mm
	machine with two side brooms	1,390 x 950 x 1,100 mm
	battery compartment	327 x 230 x 380 mm
Weight	kerb weight without batteries	82 Kg
	total kerb weight (*)	143 Kg
	gross vehicle weight (GVW)	176 Kg
Wheel specific pressure on the floor (front - rear wheels, in running conditions)		2.1 - 0.5 N/mm ²
Sound pressure level at workstation (ISO 11201, ISO 4871, EN 60335-2-72) (LpA)		70 ± 3 dB(A)
Machine sound pressure level (ISO 3744, ISO 4871, EN 60335-2-72) (LwA)		84 dB(A)
IP protection class		X3
U-turn space		1550 mm
Vibration level at the operator's arms (ISO 5349-1) (**)		< 2.5 m/s ²

(*) With batteries and empty hopper.

(**) Under normal working conditions, on a level asphalt surface.

Machine material composition and recyclability

Type	Recyclable percentage	SW900 B weight percentage
Aluminium	100 %	2.4 %
Electric motors - various	29 %	11.8 %
Ferrous materials	100 %	39.4 %
Wiring harnesses	80 %	1.8 %
Liquids	100 %	0.0 %
Plastic - non-recyclable material	0 %	9.4 %
Plastic - recyclable material	100 %	27.1 %
Polyethylene	92 %	5.9 %
Rubber	20 %	2.4 %
Cardboard - paper - wood	100 %	28.6 %

WIRING DIAGRAM**Key**

BAT	12 V batteries
CH	Battery charger
EB1	Electronic board LED
F0	System protection fuse (125 A)
F1	Filter shaker fuse (5 A)
F2	Battery charger fuse (30 A)
FA	Main motor circuit breaker (70 A)
FB	Right side broom circuit breaker (5 A)
FC	Left side broom circuit breaker (5 A) (optional)
HM	Hour counter
K0	Main motor electromagnetic switch
K1	Filter shaker relay
KEY	Ignition key
M0	Main motor
M1	Filter shaker motor
M2	Right side broom motor
M3	Left side broom motor (optional)
SW0	Hopper microswitch
SW1	Filter shaker switch
SW2	Right side broom microswitch
SW3	Left side broom microswitch (optional)

Colour codes

BK	Black
BU	Blue
BN	Brown
GN	Green
GY	Grey
OG	Orange
PK	Pink
RD	Red
VT	Violet
WH	White
YE	Yellow

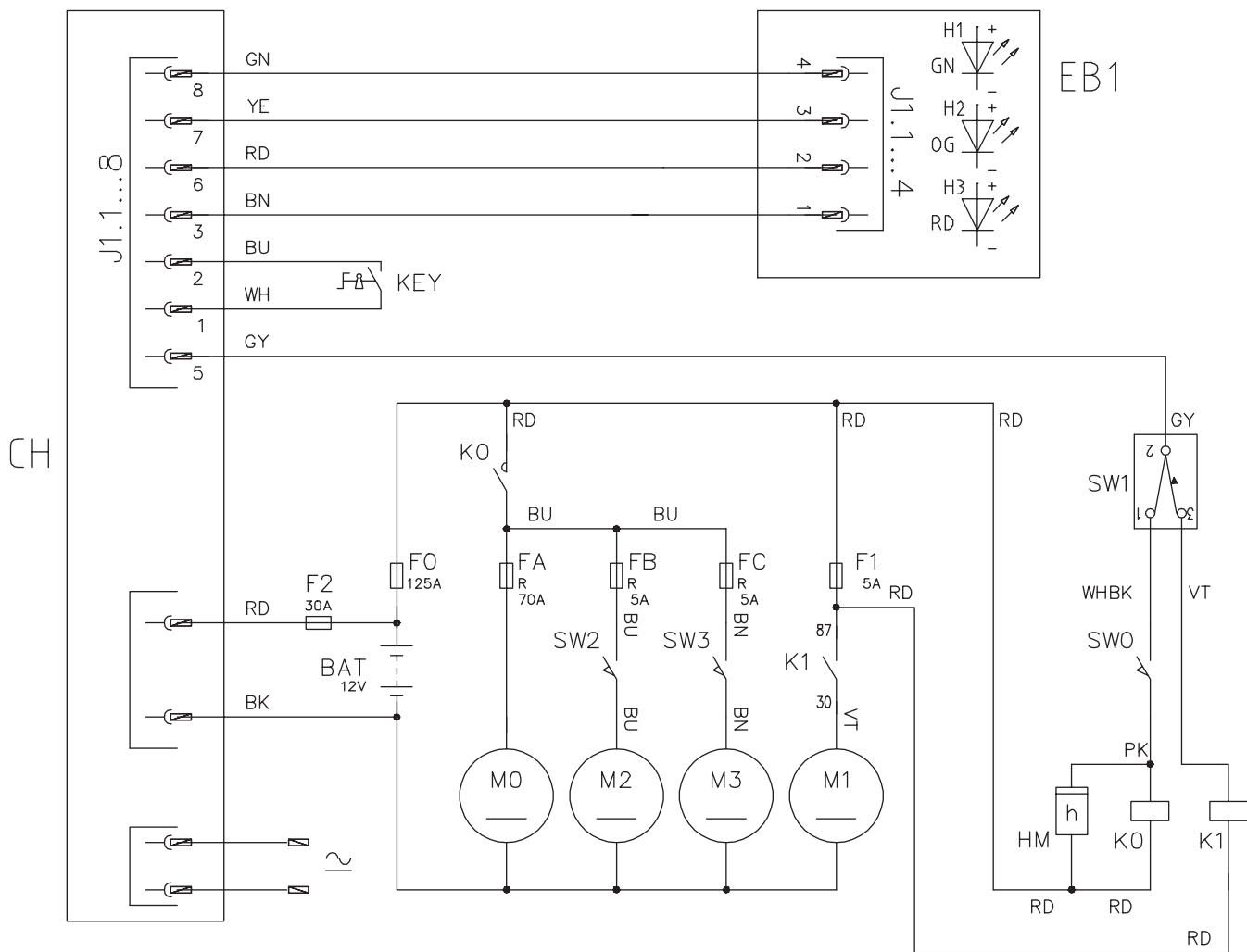

P100815

USE



WARNING!

On some points of the machine there are some adhesive plates indicating:

- DANGER
- WARNING
- CAUTION
- CONSULTATION

While reading this Manual, the operator must pay particular attention to the symbols shown on the plates (see the Visible Symbols On The Machine paragraph).

Do not cover these plates for any reason and immediately replace them if they are damaged.

BATTERY CHECK/SETTING ON A NEW MACHINE



WARNING!

The electric components of the machine can be seriously damaged if the batteries are either improperly installed or connected. The batteries must be installed by qualified personnel only.

According to the type of batteries (WET or GEL-AGM), set the machine battery charger.

Check the batteries for damage before installation.

Disconnect the battery connector and the battery charger plug.

Handle the batteries with great care.

Install the battery terminal protection caps supplied with the machine.

The machine requires one 12 V battery, or two 6 V batteries connected according to the diagram in Figure 1.

The machine can be supplied in one of the following configurations:

- WET or GEL batteries already installed on the machine
- Without batteries

According to machine configuration, proceed as follows.

a) WET or GEL-AGM batteries already installed on the machine

- Disengage the front latch (22) and open the battery and main motor hood (21), then check that the batteries are connected to the machine with the connector (36).
- Close the battery and main motor hood (21) and engage the front latch (22).
- Insert the ignition key (2) on the control panel and turn it to "I" without pulling the drive control lever (8).
If the green LED (4) turns on, the batteries are ready to be used.
If the yellow or red LED (5 or 6) turns on, the batteries must be charged (see the procedure in Maintenance chapter).

b) Without batteries

- Buy appropriate batteries (see the Technical Data paragraph and the diagram in Figure 1).
For battery choice and installation, apply to qualified battery Retailers.
- Disengage the front latch (22) and open the battery and main motor hood (21).
- Ensure that the battery connector (36) is disconnected.



WARNING!

The installed batteries may require a specific charging algorithm: to set the most appropriate charging algorithm for the installed batteries, always contact a qualified Nilfisk Service Center.

- Carefully lift the batteries to the relevant compartment, then place them as shown in Figure 1.
- Route and install the battery cable as shown in the diagrams in Figure 1, then carefully tighten the nut on each battery terminal.
- Place the protection cap on each terminal, then connect the battery connector (36).
- Close the battery and main motor hood (21) and engage the front latch (22).
- Charge the batteries (see the procedure in Maintenance chapter).

BATTERY PLUG

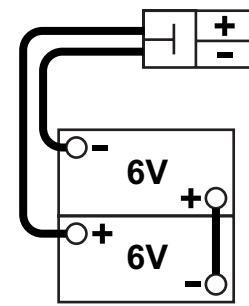

BATTERY PLUG

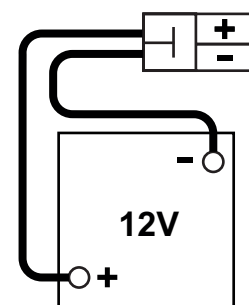

Figure 1

P100816

BEFORE MACHINE START-UP

1. Make sure that there are no open doors/hoods and that the machine is in normal operating conditions.
2. If the machine has not been used after being transported, check that all the blocks used for the transportation have been removed.
3. Check that side and main brooms are installed, otherwise install them (see the procedure in Maintenance chapter).
4. Adjust the handlebar (10) as necessary, by using the lever (11).
When the adjustment is completed, close the lever.

STARTING AND STOPPING THE MACHINE

Starting the machine

1. Insert the ignition key (2) on the control panel and turn it to "I" without pulling the drive control lever (8).
During the first 3 seconds, the battery LEDs (4, 5 and 6) flashing indicates the type of battery installed. Then, if the battery charge is sufficient, the main motor (44) turn on the main broom (27) and the vacuum fan (48).
If the green LED (4) turns on, the batteries are ready to be used.
If the yellow or red LED (5 or 6) turns on, the batteries must be charged (see the procedure in Maintenance chapter).



WARNING!

The machine cannot be started when the hopper (14) is not its position. A safety system prevents it from starting.

2. Lower the side brooms (18) and (19, optional), by pulling the levers (12) and (13, optional) backwards.



NOTE

The side brooms turn on when lowered and can be lowered and lifted even when the machine is moving.

3. Start sweeping by grasping the handlebar (10) and pulling the drive control lever (8) gradually.

Stopping the machine

1. To stop the machine, release the drive control lever (8) completely.
2. To stop the side brooms (18) and (19, optional), pull the levers (12) and (13, optional) onwards.
3. To turn off the main broom (27) and the vacuum fan (48), turn the ignition key (2) to "0".
4. Make sure that the machine cannot move independently.

MACHINE OPERATION

1. Drive the machine to the work area as shown in the previous paragraph.
2. Avoid stopping for a long time with the machine in the same position and the brooms turning: this could create unwanted marks on the floor.
3. For machine proper operation, the dust filter (41) must be as clean as possible. For cleaning it while sweeping, turn on the filter shaker by pressing the switch (3) for a few seconds. During this procedure the main motor and all functions are automatically cut-off.



NOTE

Repeat the filter shaking procedure at least every 10 minutes. This interval can change depending on the dustiness of the area to be cleaned.



NOTE

When the dust filter is clogged and/or the hopper (14) is full, the machine cannot collect dust and debris anymore.

4. When operating on wet floors, open the "wet by-pass" port (43) to avoid damaging the dust filter.
When operating on dry floors, close the "wet by-pass" port (43) to restore proper vacuuming.
5. The hopper (14) should be emptied after each working cycle and whenever it is full.



NOTE

When the hopper is full, the machine cannot collect dust and debris anymore.

HOPPER DUMPING

1. Stop the machine and turn the ignition key (2) to "0".
2. Remove the hopper (14) by using the transport handle (15) and the wheels (16) to drag it at the waste collection centre, then empty it.
3. Reinstall the hopper on the machine.
4. The machine is ready to start sweeping again.



NOTE

When the hopper is removed, all machine functions are disabled.

AFTER USING THE MACHINE

After working, before leaving the machine, perform the following procedures.

- Turn on the filter shaker with the switch (3).
- Turn the ignition key (2) to "0" to stop the machine.
- Empty the hopper (14) (see the procedure in the previous paragraph).
- Lift the side brooms (18) and (19, optional), by pulling the levers (12) and (13, optional) onwards.
- Make sure that the machine cannot move independently.
- Charge the batteries (see the procedure in Maintenance chapter).

PUSHING THE MACHINE

The machine can be pushed both with the ignition key (2) to "0" and to "1".

MACHINE LONG INACTIVITY

If the machine is not going to be used for more than 30 days, proceed as follows:

- Perform the procedures shown in After Machine Use paragraph.
- Check that the machine storage area is dry and clean.
- Disconnect the battery connector (36).
- Slightly lift the machine so that the skirts, the main broom and the wheels do not touch the ground.

MAINTENANCE

The lifespan of the machine and its maximum operating safety are ensured by correct and regular maintenance.

The following table provides the scheduled maintenance. The intervals shown may vary according to particular working conditions, which are to be defined by the person in charge of the maintenance.

All scheduled or extraordinary maintenance procedures must be performed by qualified personnel, or by an authorised Service Center.

This Manual describes only the easiest and most common maintenance procedures.

For other maintenance procedures shown in the Scheduled Maintenance Table, refer to the Service Manual that can be consulted at any Service Center.



WARNING!

To perform maintenance procedures, the machine must be off, the ignition key removed, and, if necessary, the batteries must be disconnected.

Read carefully the instructions in the Safety chapter before performing any maintenance procedure.

SCHEDULED MAINTENANCE TABLE

Procedure	Upon delivery	Every 10 hours	Every 50 hours	Every 200 hours	Every 400 hours
Battery charging	(1)				
Battery (WET) fluid level check					
Battery charger cable check					
Dust filter cleaning and integrity check		(2)			
Side and main broom height check and adjustment					
Skirt height and operation check					
Filter gasket check					
Electrical filter shaker operation check				(*)	
Driving belt check/adjustment: drive system, main broom.				(*)	
Hopper position microswitch operation check					
Driving belt replacement: drive system, main broom.				(*)	
Motor carbon brush check or replacement					(*)

(*) For the relevant procedure, refer to the Service Manual.

(1) Daily or after using the machine.

(2) Or before use.

BATTERY CHARGER CABLE CHECK

Carefully check the battery charger cable (38) and the relevant plug for wear, cuts, cracks or other damages. If the battery charger cable or the relevant plug is damaged, contact the Nilfisk Service Center.

BATTERY CHARGING**CAUTION!**

Charge the batteries when the yellow (5) or red LED (6) turns on, or at the end of each cleaning cycle. Keeping the batteries charged make their life last longer.

**WARNING!**

When the batteries are discharged, charge them as soon as possible, as that condition makes their life shorter.

**WARNING!**

If the machine is equipped with lead (WET) batteries, battery charging produces highly explosive hydrogen gas. Charge the batteries in well-ventilated areas and away from naked flames. Do not smoke while charging the batteries. While charging the batteries always keep the hood open.

**WARNING!**

Pay careful attention when charging WET batteries as there may be battery fluid leakages. The battery fluid is corrosive. If it comes in contact with skin or eyes, rinse thoroughly with water and consult a physician.

1. Drive the machine on a level floor. Make sure that the machine cannot move independently.
2. Turn the ignition key (2) to "0".
3. Connect the cable (38) of the electronic battery charger (40) to the electrical mains.

**WARNING!**

The mains voltage and frequency must match the electronic battery charger values shown on the machine serial number plate (47).



NOTE

When the electronic battery charger is connected to the electrical mains, all machine functions are automatically disabled.

4. When the green LED (4) turns on, the batteries are charged.
For further information about the battery charger operation (40), see the Battery Charger Manual.
5. Disconnect the electronic battery charger cable (38) from the electrical mains and place it in its housing (39) on the machine.
6. Now the machine is ready to be used.

MAIN BROOM HEIGHT CHECK AND ADJUSTMENT



NOTE

Brooms with harder or softer bristles are available.
This procedure is applicable to all types of brooms.

Check

7. Check the main broom distance from the ground, according to the following procedure:
8. Drive the machine on a level floor.
9. Keep the machine stationary and turn on the main broom for a few seconds.
10. Stop the main broom, then move the machine and turn it off.
11. Check that the main broom print (A, Fig. 2), along its length, is 2 to 4 cm wide.
12. If the print (A) is not within specifications, adjust the broom height.

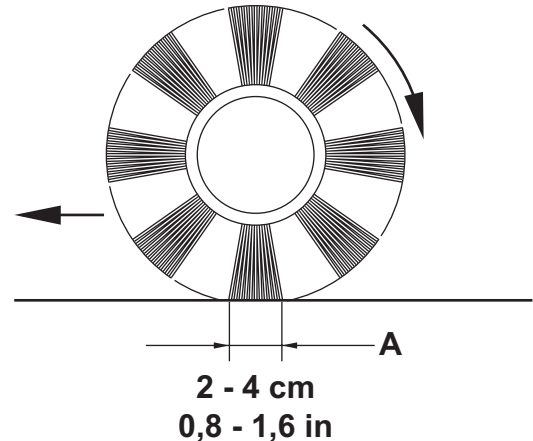

Figure 2

P100817

Adjustment

13. Turn the ignition key (2) to "0".
14. Turn the knob (B, Fig. 3) as shown below:
 - to increase the print width, turn the knob counter-clockwise
 - to decrease the print width, turn the knob clockwise



NOTE

The knob can be used both to adjust the print and to adjust the broom according to the bristle wear.

15. Perform step 1 again to check that the main broom is at the correct distance from the ground.
16. When the broom is too worn to be adjusted, replace it as shown in the next paragraph.



CAUTION!

If the main broom print is excessive (larger than 4 cm), the machine regular operation is affected and the moving parts or electrical components can overheat, thus reducing machine life.
Pay careful attention when performing the above-mentioned checks, and always use the machine according to the indicated conditions.

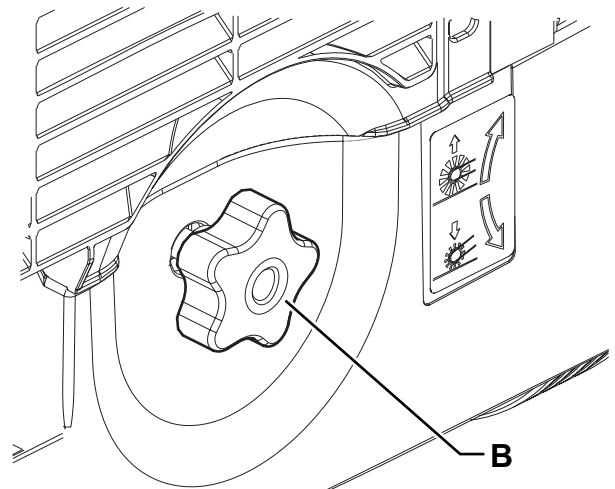

Figure 3

P100818

MAIN BROOM REPLACEMENT



CAUTION!

It is advisable to wear protective gloves when replacing the main broom because there can be sharp debris between the bristles.

1. Drive the machine on a level floor.
2. Turn the ignition key (2) to "0".
3. Turn the main broom height adjusting knob (28) fully clockwise.
4. Remove the hopper (14).
5. Turn the knob (23) and open the left door (A, Fig. 4).
6. Loosen the knobs (B) and remove the main broom cover (C) by slightly turning it counter-clockwise.
7. Remove the main broom (D) from the front side of the machine.
8. Check that the drive hub (E) is free from dirt or foreign materials (cords, rags, etc.) accidentally rolled up.
9. Place the new main broom with the bristles rows (F) bent as shown in the figure.
10. Install the new main broom on the front side of the machine, and ensure that the mesh (G) properly fits into the relevant drive hub (E).
11. Install the main broom cover (C) and tighten the knobs (B).
12. Close the left door (A).
13. Adjust the main broom height as shown in the previous paragraph.

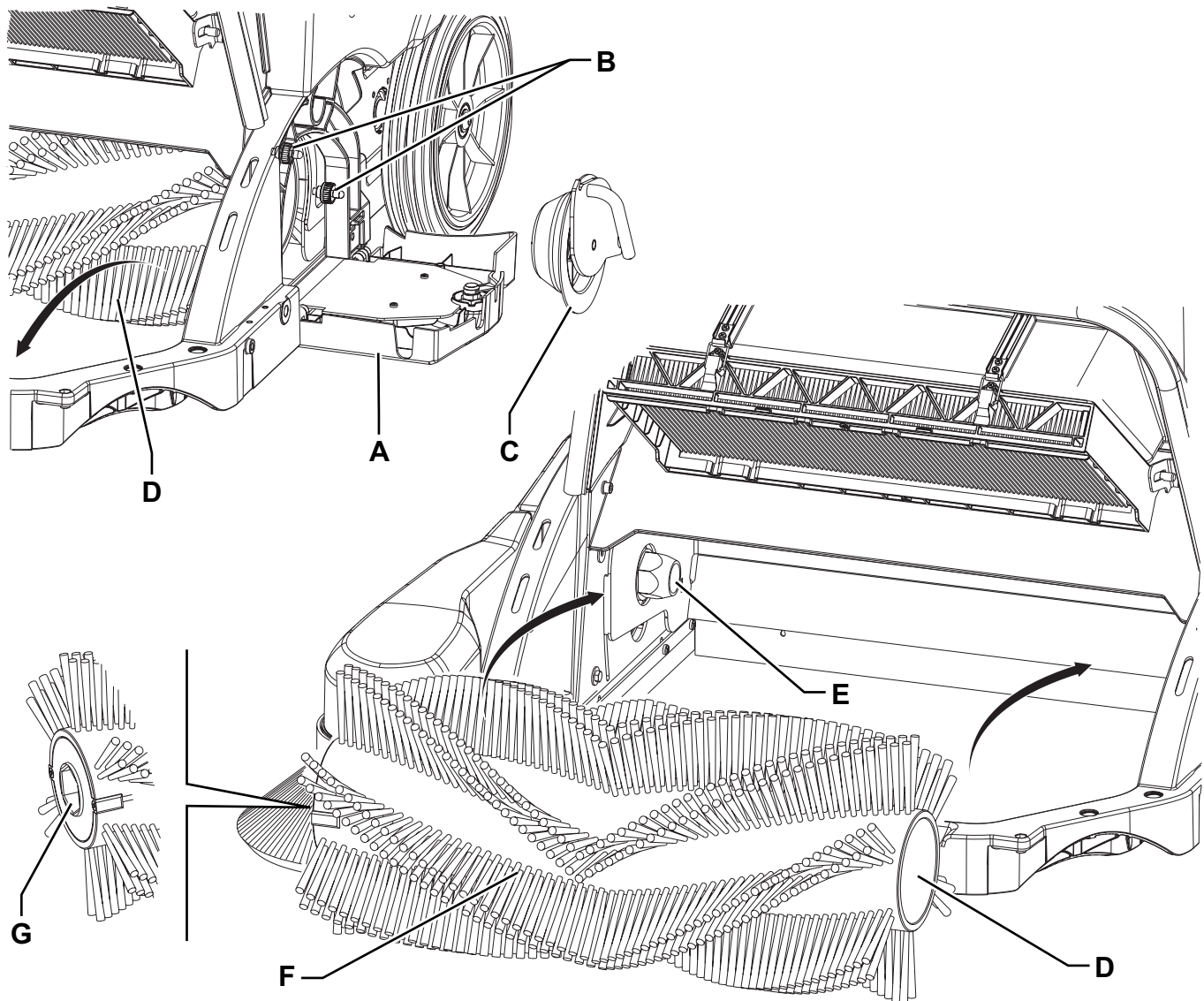

Figure 4

P100819

SIDE BROOM HEIGHT CHECK AND ADJUSTMENT

i NOTE
Brooms with harder or softer bristles are available.
This procedure is applicable to all types of brooms.

i NOTE
This procedure is applicable to both the right side broom and left side broom (optional).

Check

1. Drive the machine on a level floor.
2. Turn the ignition key (2) to "I".
3. Lower the side broom with the lever (12).
4. The proper side broom height is reached when the bristles touch the floor along a circle arc as shown (A, Fig. 5).
If the print (A) is not within specifications, adjust the broom height.

Adjustment

5. Turn the ignition key (2) to "0".
6. Loosen the nut (C, Fig. 6) under the cover (B) and turn the screw (D) clockwise or counter-clockwise to increase or decrease the side broom height. Then lock the screw with the nut.
7. Perform step 4 again to check that the side broom is at the correct distance from the ground.
8. When the broom is too worn to be adjusted, replace it as shown in the next paragraph.

! CAUTION!
If the side broom print is excessive, the machine regular operation is affected and the moving parts or electrical components can overheat, thus reducing machine life.

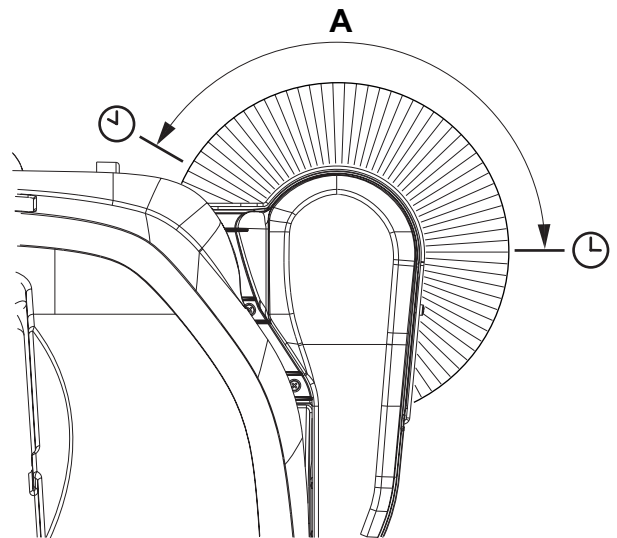

P100820

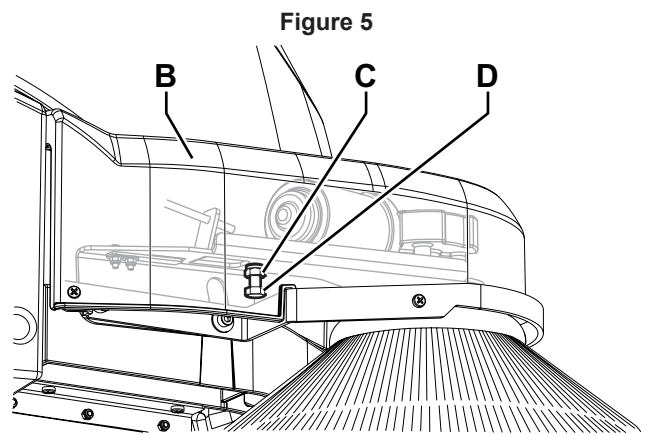

Figure 5

Figure 6

P100821

SIDE BROOM DISASSEMBLY/ASSEMBLY

! CAUTION!
It is advisable to wear protective gloves when replacing the side broom because there can be sharp debris between the bristles.

i NOTE
This procedure is applicable to both the right side broom and left side broom (optional).

1. Drive the machine on a level floor.
2. Turn the ignition key (2) to "0".
3. Loosen the knob (A, Fig. 7) inside the side broom, then remove the broom (B) by disengaging it from the three pins (C).
4. Install the new broom on the machine engaging it on the pins (C), then tighten the knob (A).
5. Adjust the height of the new broom according to the procedure shown in the previous paragraph.

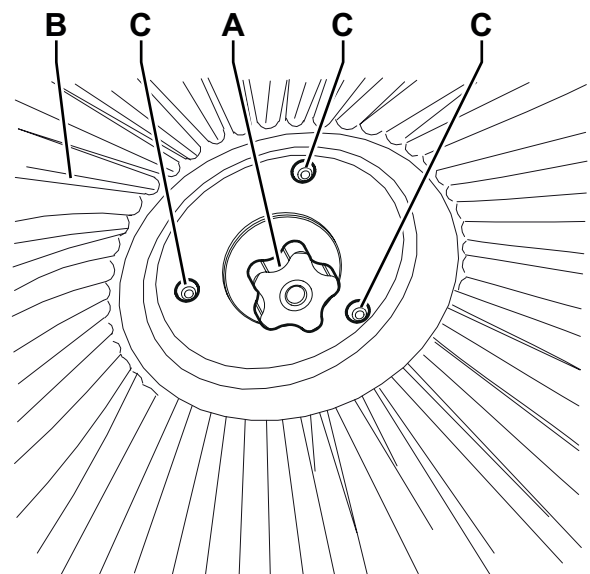

Figure 7

P100822

SKIRT CHECK AND ADJUSTMENT

1. Drive the machine on a level floor that is suitable for checking the skirt height. Make sure that the machine cannot move independently.
2. Turn the ignition key (2) to "0".
3. Remove the hopper (14).
4. Remove the main broom (27) as shown in the relevant paragraph.

Side Skirt Check

5. Check the side skirts (26) for integrity. Replace the skirts when they have cuts (A, Fig. 8) larger than 20 mm or cracks/tears (B) larger than 10 mm (for skirt replacement, refer to the Service Manual).
6. Check that the height of the side skirts (26) is as shown in the figure (C), the side skirts must touch the floor all along their length.
7. If necessary, adjust the skirts according to the following procedure.

Side Skirt Adjustment

8. Remove the right door (37) to reach the nuts (D, Fig. 9).
9. Loosen the nuts (D) and the screw (E), then adjust the height of the right side skirt (F) by using the slots of the mounting holes.
10. Loosen the screws (G) and adjust the height of the right side recovery skirt (H) by using the slots of the mounting holes.
11. Loosen the screws (I) and the nuts (J), then adjust the height of the left side skirt (K) by using the slots of the mounting holes.
12. After that, tighten the screws and nuts.



NOTE

The adjustment procedure is applicable to both the right side recovery skirt (H) and left side recovery skirt (optional).

Front Skirt Check and Rear Skirt Check/Adjustment

13. On the hopper (14), check the front skirt (24) for integrity.
14. Check the rear skirt (25) for integrity.
15. Replace the skirts when they have cuts (A, Fig. 8) larger than 20 mm or cracks/tears (B) larger than 10 mm (for skirt replacement, refer to the Service Manual).
16. Check that the height of the rear skirt (25) is as shown in the figure (C), the skirt must touch the floor all along its length.
17. If necessary, loosen the screws (L, Fig. 10) and adjust the height of the skirt (M) by using the slots of the mounting holes.
18. When the adjustment is completed, tighten the screws (L).
19. Assemble the components in the reverse order of disassembly.



NOTE

The front skirt (24) on the hopper does not require to be adjusted.

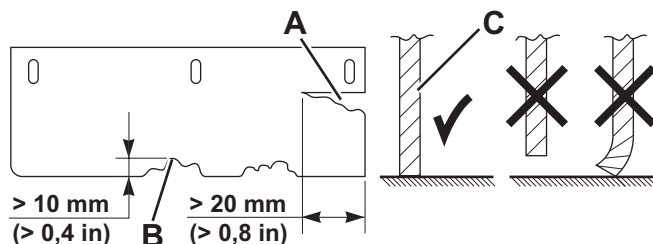

P100823

Figure 8

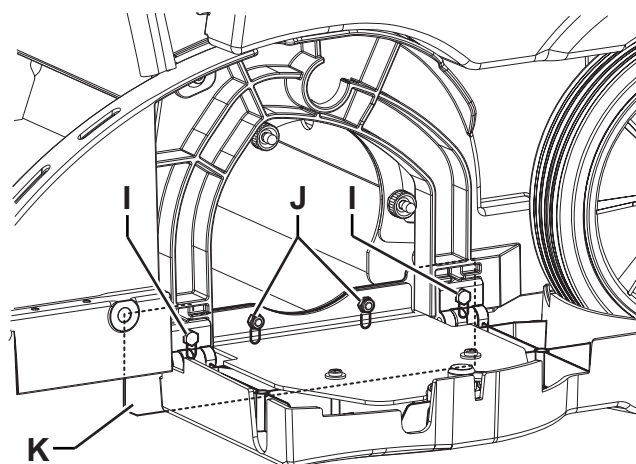
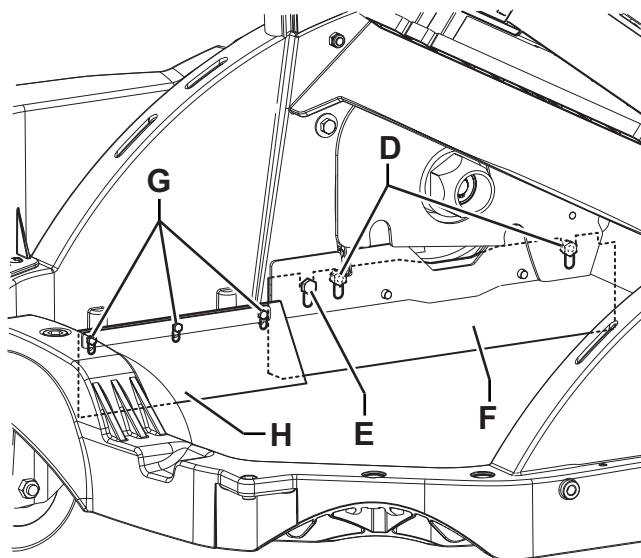

P100825

Figure 9

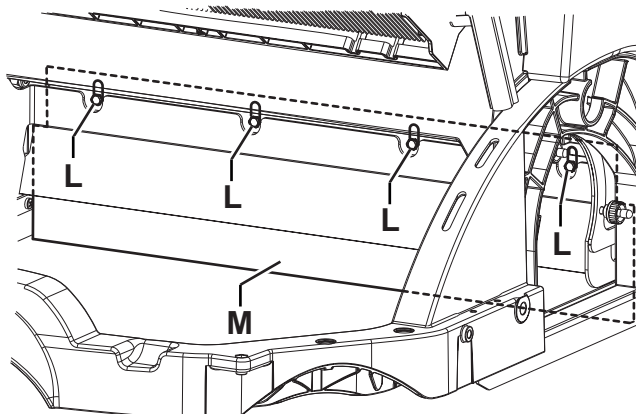

P100826

Figure 10

DUST FILTER CLEANING AND INTEGRITY CHECK

The dust filter must be regularly cleaned to maintain the efficiency of the vacuum system. Follow the recommended filter service intervals for the longest filter life.



WARNING!

Wear safety glasses when cleaning the filter.
Do not puncture the filter.
Clean the filter in a well-ventilated area.
Wear appropriate dust mask to avoid breathing in dust.



NOTE

Besides the standard polyester filter, paper filter is also available.

1. Drive the machine on a level floor and ensure that it cannot move.
2. Turn the ignition key (2) to "0".
3. Remove the hopper (14).
4. Disengage the levers (A, Fig. 11) and turn the filter holder (B) downwards.
5. Remove the dust filter (C).
6. In an outdoor area, clean the dust filter by shaking it on a level and clean surface, tapping the side (E, Fig. 12) opposite to the wire gauze (F).
7. Complete the cleaning procedure by using compressed air (G) at maximum 6 Bar, blowing only from the side protected by the wire gauze (F).
 Moreover, according to the filter type, observe the following cautions:
 - Polyester filter (standard): For a better cleaning, it is allowed to wash the filter with water and non-lathering detergents. This provides better quality cleaning but reduces the life of the filter, which will have to be replaced more frequently. The use of inadequate detergents can damage the filter.
 - Paper filter (optional): Do not use water or detergents to clean it, otherwise it can be damaged.
8. Check the filter body for tears. Clean the gasket (H) along its perimeter and check it for integrity. If necessary, replace the filter.
9. If necessary, clean the filter compartment rubber gasket (D, Fig. 11) along its perimeter and check it for integrity. If necessary, replace it.
10. Assemble the components in the reverse order of disassembly.

Pre-filter Cleaning (optional)

11. Perform steps 1 to 3.
12. Remove the pre-filter (K, Fig. 13) and clean it with compressed air at maximum 6 Bar.
13. Assemble the components in the reverse order of disassembly.

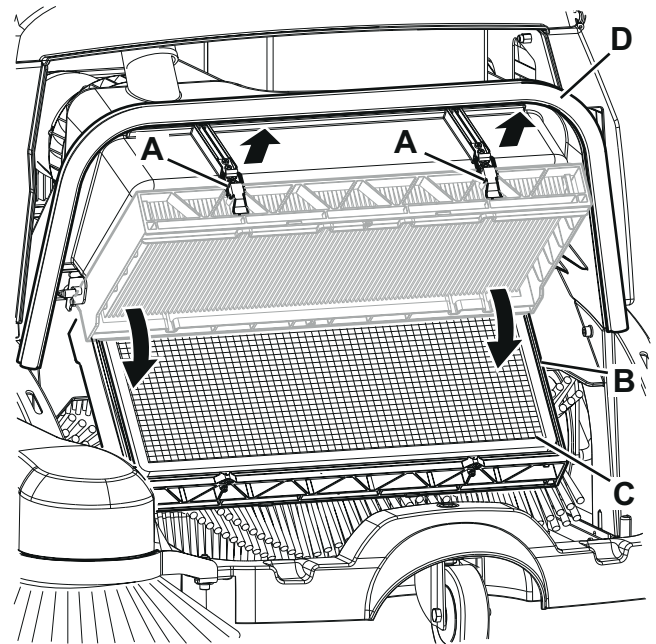

Figure 11

P100827

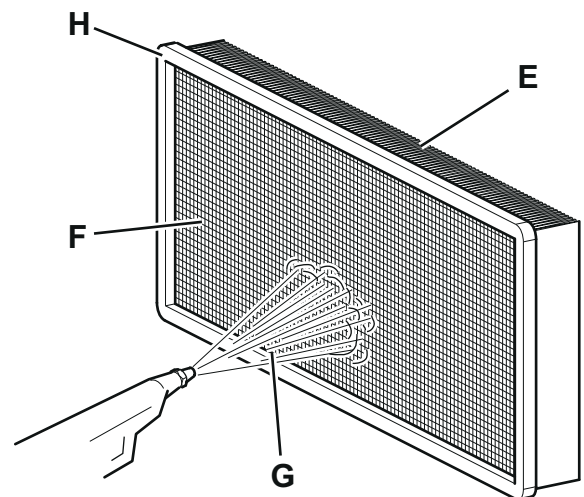

Figure 12

P100828

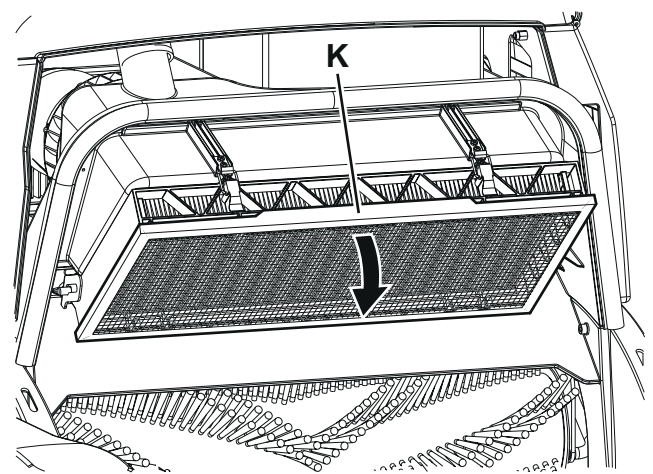

Figure 13

P100829

HOPPER POSITION MICROSWITCH OPERATION CHECK

1. Turn off the machine and remove the hopper (14).
2. Try to start the machine by turning the ignition key (2) to "I". The machine should not start. Turn the ignition key (2) to "0".
3. Reinstall the hopper (14).
4. If the machine keeps operating when the hopper (14) has been removed, contact an authorised Service Center or Retailer immediately.

FUSE CHECK/REPLACEMENT/RESET

1. Drive the machine on a level floor. Make sure that the machine cannot move independently.
2. Turn the ignition key (2) to "0".

Fuse Check

3. Check one of the following fuses for deactivation:
(32): Main motor fuse FA (70 A).
(33): Right side broom motor fuse FB (5 A)
(34): Left side broom motor fuse FC (5 A) (optional)
Reset any deactivated fuse, when the component that caused deactivation has fully cooled down.

Fuse check/replacement

4. Disengage the front latch (22) and open the battery and main motor hood (21).
5. Disconnect the battery connector (36).
6. Check/replace the relevant fuse among the following:
(29): Battery fuse F0 (125 A).
(30): Electrical filter shaker fuse F1 (5 A).

Check/replace the battery charger fuse (31) as follows:

7. Open the rear grid (51) by loosening the mounting screws.
8. Open the fuse holder and check/replace the F2 fuse (30 A).

Reassembly

9. Connect the battery connector (36).
10. Close the battery and main motor hood (21) and engage the front latch (22).
11. Close the rear grid (51) and tighten the screw.

BATTERY ELECTROLYTE LEVEL CHECK (FOR WET BATTERIES ONLY)

1. Disengage the front latch (22) and open the battery and main motor hood (21).
2. Check the level of electrolyte inside the batteries (35). If necessary, top up through the caps.
3. Close all the battery caps (35).
4. Close the battery and main motor hood (21) and engage the front latch (22).
5. If necessary, charge the batteries as shown in the relevant paragraph.

TROUBLESHOOTING

Trouble	Possible cause	Remedy
The machines functions are not enabled when turning the ignition key to "I".	The battery connector is disconnected.	Open the hood and connect the battery connector.
	The hopper is not in its proper position.	Place the hopper properly.
	The main motor circuit breaker (FA) is open.	Wait for the main motor to cool down, then reset the fuse by pressing the relevant push-button.
	The electronic battery charger is connected to the electrical mains.	Disconnect the electronic battery charger from the electrical mains.
	The hopper microswitch is broken.	Replace the microswitch. (*)
The side broom does not operate.	The fuse (FB) or (FC) (optional) is open.	Wait for the side broom motor to cool down, then reset the fuse by pressing the relevant push-button.
	The side broom microswitch is faulty.	Replace the relevant side broom microswitch. (*)
The machine collects little debris/dust.	The dust filter is clogged.	Clean the dust filter by using the filter shaker or by disassembling it.
	The hopper is full.	Empty the hopper.
	The skirts are not properly adjusted or are broken.	Adjust/replace the skirts.
	The brooms are not properly adjusted.	Adjust the broom height.
	The main broom belt is misadjusted or worn.	Adjust or replace the main broom belt. (*)
The electrical filter shaker does not work.	The fuse (F1) is open.	Replace the fuse.
The machine operates only when stationary, otherwise the red warning light turns on.	The batteries are discharged.	Charge the batteries. If the trouble persists, replace the batteries.
The battery autonomy is low.	The batteries are dead.	Replace the batteries.
	The batteries capacity is low.	Buy batteries with higher capacity (see the Technical Data paragraph).
When pulling the drive control lever, the machine does not move, or it moves slowly.	The drive control cable is misadjusted or broken.	Adjust or replace the drive control cable. (*)
	The driving belt is misadjusted or worn.	Adjust or replace the driving belt. (*)

(*) Procedure to be performed by Nilfisk Service Center.



NOTE

The machine cannot operate without the battery charger. In case of battery charger failure, contact an authorised Service Center.

For further information contact a Nilfisk Service Center, where it is possible to consult the Service Manual.

SCRAPPING

Have the machine scrapped by a qualified scrapper.

Before scrapping the machine, remove and separate the following materials, which must be disposed of properly according to the Law in force:

- Batteries
- Polyester dust filter
- Main and side brooms
- Plastic hoses and components
- Electrical and electronic components (*)

(*) Refer to the nearest Nilfisk Center especially when scrapping electrical and electronic components.

Nilfisk Equipamentos de Limpeza Ltda.
São Paulo - SP - Brasil
Phone: +55(11) 3959-0300
www.nilfisk.com.br

