

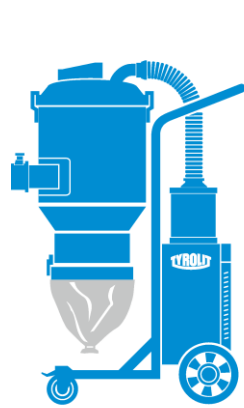

## **OPERATING INSTRUCTIONS**

**VCE1200D | VCE2400D | VCE3600D**

Index 000



VCE1200D

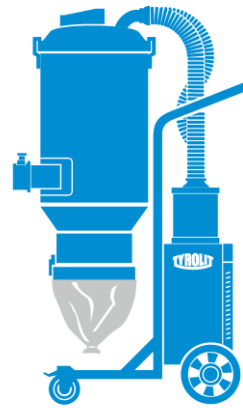

VCE2400D

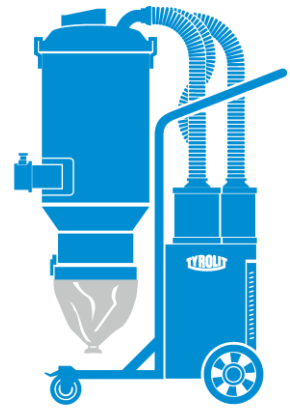

VCE3600D

Original instructions

11005302/11005307/11005312 en / 01.10.2022



## **Congratulations!**

You have decided to purchase a tried-and-tested TYROLIT unit and have thus acquired a highly sophisticated and reliable state-of-the-art device. Only genuine TYROLIT replacement parts can guarantee quality and interchangeability.

If maintenance work is neglected or carried out inexpertly, we will be unable to honour our warranty obligations. All repairs must be carried out by trained personnel only.

Our after-sales service is available to help ensure that your TYROLIT units remain in perfect working order.

We hope that working with your TYROLIT unit will be a satisfying and fault-free experience.

TYROLIT

Copyright © TYROLIT Hydrostress

TYROLIT Hydrostress AG  
Witzbergstrasse 18  
CH-8330 Pfäffikon  
Switzerland  
Telefon 0041 (0) 44 952 18 18  
Telefax 0041 (0) 44 952 18 00

## 1 Safety



This vacuum cleaner is for indoor and dry application only, don't use outdoor or pick up liquid or any wet particles.



### **DANGER**

This vacuum cleaner must not be used in environments where explosive gases may be present serious risk of explosion.



### **WARNING**

This vacuum cleaner is not suitable to extract solid particles with sharp shape, which will cause damage to the hose, filters, drum and continuous plastic bags.



### **WARNING**

This vacuum cleaner contains dust hazardous to health. Emptying and maintenance operations, including removal of the dust collection means, must only be carried out by authorized personnel wearing suitable personal protection. Do not operate without the full filtration system fitted.

### 1.1 Electric safety

- ▶ Before using the vacuum cleaner, carefully check the cords are not exposed or damaged.
- ▶ Confirm that the voltage and current of your available power can hold up to rated power supply of machine.
- ▶ The vacuum cleaner must be switched off and unplugged while an operator leaves in a long period.

### 1.2 Personal Safety Protection

- ▶ Keep children and pets away from the machine while the vacuum cleaner is on work.
- ▶ This vacuum cleaner must be handled by an experienced operator, or by an adult with necessary training.
- ▶ Wear personal safety protection equipment like gloves, goggles, masks and earplug while using the vacuum cleaner.
- ▶ Do not touch the plug, electrical wire or other electric components while vacuum cleaner in running.

### 1.3 Maintenance

- ▶ Before maintenance, make sure that the vacuum cleaner unplugged and power off.
- ▶ While changing or fixed the electric components, only experience workers or the one who has sufficient acknowledge on electrics.
- ▶ Use proper hand tools or electric tools while assembling or disassembling the vacuum cleaner, in case of damaging the nuts and bolt, and causing unnecessary body injury.

## 1.4 Storage

- ▶ Vacuum cleaner shall be stored in dry environment indoors, never store outdoors.
- ▶ Perform the necessary cleaning of the vacuum cleaner before storing it to ensure the longest possible life.

## 1.5 Symbols on the device



### Wear breathing mask

Wearing a breathing mask is mandatory when operating the vacuum cleaner.



### Wear hearing protection

Wearing hearing protection is mandatory when operating the vacuum cleaner.



### Wear protective glasses

Wearing safety glasses is mandatory when operating the vacuum cleaner.



### HEPA filter

This device is equipped with a high efficiency particulate air (HEPA) filter.  
Use original filters only.



### H-classification

This device is H-classified and certified according to EN/IEC-60335-2-69, Annex AA. This equipment contains dust that is harmful to health. The emptying, as well as maintenance operations, including the removal of the dust collector, may only be carried out by qualified personnel wearing suitable protective equipment. Never operate the vacuum cleaner without the complete filter system.

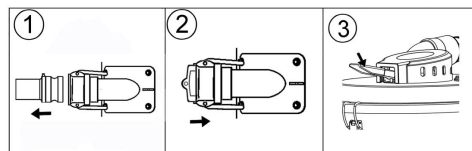

### Filter cleaning procedure

Follow the procedure according to this label to clean the filter.

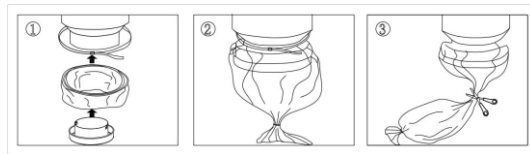
**Dust collection installation**

Follow the procedure according to this label to install the dust collection system.

## 2 Description

### 2.1 Vacuum cleaner

The device is a single-phase vacuum cleaner.

The three-stage device separates the dust particles from the air. The particles fall into the plastic bag at the bottom of the unit.

1. The dust or particles sucked up by the inlet will fall into the plastic by gravity or by centrifugal force.
2. The rest of the dust and particles are retained by the built-in pre-filter with a filtration rate of up to 99.5% @ 1µm; by operating the jet pulse handle, dust and particles also fall into the plastic bag.
3. The remaining dust is retained in the HEPA filter with an efficiency of up to 99.99% @ 0.3µm.

### 2.2 Intended use

This device is designed for vacuuming dry, non-flammable dust and solid waste using the filters provided.

Do not use the device for other tasks.

This device is intended for commercial use, e.g. on construction sites, in factories, stores, offices, etc. and can also be used directly with processing machines.

Not suitable for use in potentially explosive atmospheres.

### 2.3 Main components

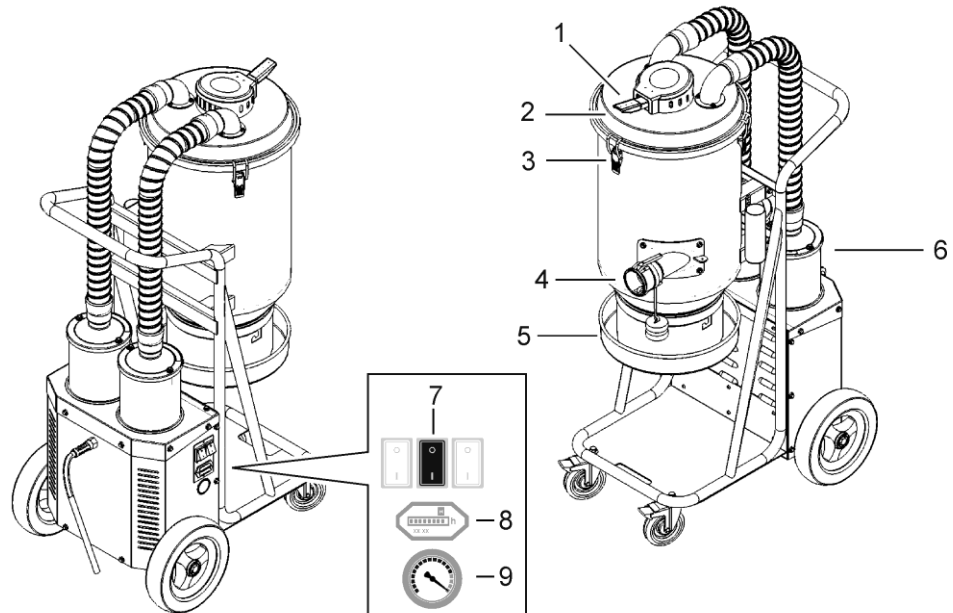

Vacuum cleaner overview

- |   |                                   |   |                        |
|---|-----------------------------------|---|------------------------|
| 1 | Jet-pulse handle                  | 6 | HEPA filter            |
| 2 | Pre-filter                        | 7 | ON/OFF switch/switches |
| 3 | Draw latch                        | 8 | Operating hour meter   |
| 4 | Suction hose connection (Camlock) | 9 | Manometer              |
| 5 | Continuous bag holder             |   |                        |

## 3 Mounting

### 3.1 Unpacking



Below listed accessories will come with every single vacuum cleaner, please contact your local distributor or sales representatives if below mentioned accessories are missing.

<b>VCE1200D</b>	<b>VCE2400D</b>	<b>VCE3600D</b>
1x hose D38 x 5mm	1x hose D50 x 7.5mm	1x hose D50 x 7.5mm
2x hose cuff	2x hose cuff	2x hose cuff
1x suction pipe	1x suction pipe	1x suction pipe
1x round brush	1x floor brush	1x floor brush
1x floor brush	1x crevice tool	1x crevice tool
1x crevice tool		

### 3.2 Assembling

- ▶ Remove the sealing cap on the hose connection
- ▶ Insert the suction hose and secure it with the camlock clamps
- ▶ Attach brush to the suction hose

## 4 Operation

### 4.1 Preparation

**WARNING**

Before using the device, read the chapter on device safety and the operating instructions.

**WARNING**

Before using the vacuum cleaner, make sure that the power supply and voltage correspond to the voltage specified on the type plate of the device, including extension cord.

**WARNING**

The vacuum cleaner must be grounded to reduce the risk of electric shock.

### 4.2 Start and stop

Use the switch (VCE1200) / switches (VCE2400 and VCE3600) to start the vacuum cleaner.



It is possible to switch each sucking blower motor. For VCE2400 and VCE3600 it is therefore possible to reduce the sucking power by switching less than all switches. Note that in this case the HEPA filters are not evenly charged with dust.

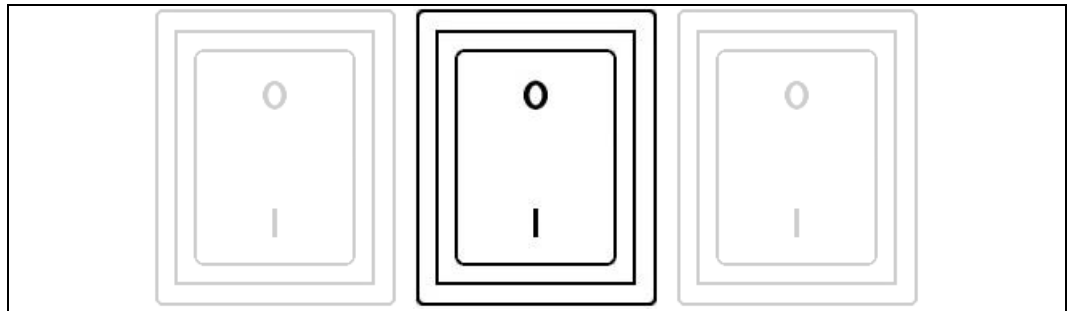

Main switch/switches

- 0 OFF
- I ON

## 5 Servicing and maintenance

**Maintenance and servicing table**

		Before starting up	On finishing work	Weekly	Every 6 months	Every 12 months	When suction is low
Vacuum cleaner	▶ Look for signs of wear and damage.	X					
Dust collection system	▶ Check the correct fit of the continuous plastic bag.	X	X				
Filter cleaning system	▶ Check the filter cleaning system.	X	X				
	▶ Clean the pre-filter						X
	▶ Replace the pre-filter				X		X
	▶ Replace the HEPA filter					X	X
Chassis	▶ Check the wheels for wear and damage.			X			



### **WARNING**

#### **Electric hazard!**

When cleaning or servicing the vacuum cleaner, you must turn off the power and unplug the unit.

### **5.1 Dust collection system**



The dust collection system consists of a bag holder, a nylon belt with metal buckle, nylon ties and a continuous plastic bag.



**WARNING**

Dispose the bags into the dust bin or at the assigned area.

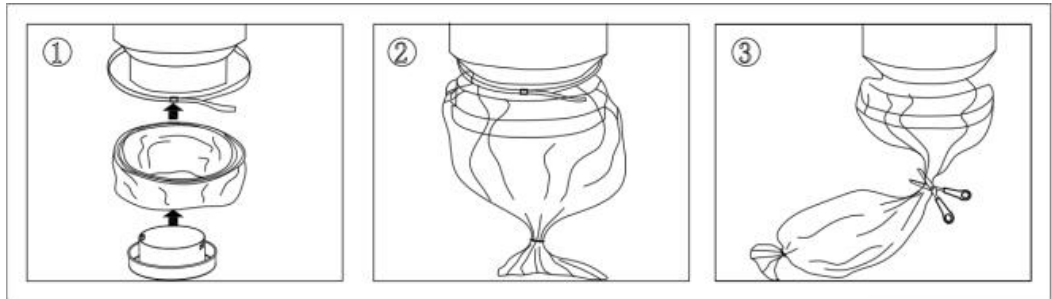

Changing the dust bag

1. Unlock the bag holder and put the continuous bag into the holder
2. Tie up the bottom of the bags with nylon ties, fasten the nylon puller strap for sealing and close the bag end with a cable tie
3. While the bag is full of dust or particles, tie up the top of the bag with 2 nylon ties, finally cut the bag between the 2 nylon ties to prevent the dust from escaping.

**5.2 Filter cleaning**



The filter must be cleaned from time to time. This must be done before changing the plastic bag collection system and should also be done after finishing work or when the suction performance is poor.

When using with processing machines, make sure that the filter is cleaned regularly and that the suction hoses do not show any blockages. This ensures the necessary air velocity to transport the dust safely into the pre-filter.

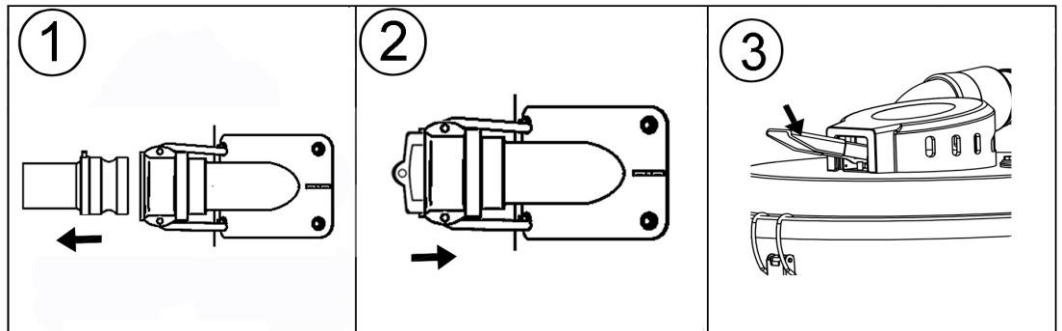

Filter cleaning

1. Remove suction hose
2. Install suction connection plug
3. Press the jet-pulse handle for 5 seconds and repeat this procedure for 4-5 times. Wait 5 second between every interval.  
Remove the plug from the suction connection and install the suction hose again.

### 5.3 Filter Change



To ensure the certified filter performance, use original spare parts only.



#### WARNING

The operator must wear breathing mask, protective glasses and gloves while changing the filter to prevent inhalation of the dust.

### 5.4 Pre-filter change



If you clean the filter with water, make sure only low pressure water will be used. Otherwise the filter can be destroyed.

The filter must be completely dry before you insert it into the housing again.

- ▶ Prepare a clean and empty bag in which the filter will be put.
- ▶ Loosen the 3 draw latches, take the main drum cover off.
- ▶ Lift out the filter gently, put it into the bag and seal the bag.
- ▶ Insert a new filter.

### 5.5 HEPA filter change



#### CAUTION

Do not try to clean HEPA filters, as the filter media will be destroyed.

Do not touch the inside of the filter during change. Any damage on the filter media will destroy the new filter.

- ▶ Prepare a clean and empty bag in which the filter will be put.
- ▶ Loose the 2 nuts on HEPA tube cover and take the filter cover off.
- ▶ Lift out the filter gently, put it into the bag and seal the bag.
- ▶ Insert a new filter.

### 5.6 Cleaning



#### CAUTION

Cleaning using high-pressure cleaning equipment is not permitted.

- ▶ Before removing the vacuum cleaner from the work area, it must first be cleaned.
- ▶ All other equipment must be regarded as contaminated and be treated thereafter.
- ▶ If possible, use a special suitable room.
- ▶ Proper personnel protective equipment must be worn.
- ▶ All parts that are contaminated after maintenance must be carefully disposed of in plastic bags according to local regulations.

## 6 Troubleshooting

The owner of the vacuum cleaner must follow all instructions in this user manual and carefully operate and maintain the vacuum cleaner. All parts must be checked in time to ensure that all parts such as seals, filters, metal parts, welding points, bags, motors, etc. are in good order.

<b>Trouble</b>	<b>Cause</b>	<b>Solution</b>
Motor does not start	No power	Plug in device
	Cable defective	Replace cable
	Switch defective	Replace switch
Motor stops immediately after starting	Electrical fuse too weak	Connect to correct fuse
	Shortcut in cable/machine	Order service
Motor runs but there is no suction power	Hose not connected	Connect hose
	Hose clogged/blocked	Clean hose
	No dust collection bag	Fit dust collection system
	Dust collection system is leaking	Check for damaged dust collection bag and fit dust collection system correctly
Motor runs but poor suction	Hole in hose	Replace hose
	Filter clogged	Clean or replace filter
	Loose top cover	Adjust the cover
	Defective gasket(s)	Replace affected gasket
Dust blown from motor	Wrongly assembled or damaged filter system	Adjust/replace filter
Abnormal noise		Order service

## 7 Technical Data

Data	Unit	VCE1200D	VCE2400D	VCE3600D
Voltage	V	230	230	230
Frequency	Hz	50-60	50-60	50-60
Power	W	1200	2400	3600
	HP	1.6	3.2	4.8
Current	A	5	10	15
Airflow (max)	m <sup>3</sup> /h	200	400	600
Vacuum (max)	hPa (mbar)	220	220	220
Main hose		D38 x 5m	D50 x 7.5m	D50 x 7.5m
Air Inlet	mm	38	50	50
Pre-filter	99.5% @ 1µm			
Pre-filter area	m <sup>2</sup>	1.5	3.0	4.5
HEPA filter EN1822-H13	99.99% @ 0.3µm			
	pcs.	1	2	3
Total HEPA filter area	m <sup>2</sup>	1.2	2.4	3.6
Sound press. level L <sub>pA</sub>	dB(A)	75.5	79.5	85.0
Acoustic power level L <sub>WA</sub>	dB(A)	86.5	91.5	99.5
Dust Collection	Continuous plastic bag (Longopac®) Ø357mm (14")			
Dimension (LxWxH)	mm	426x704x1115	544x729x1318	544x860x1459
Weight	kg	36	59	78

## EC Declaration of Conformity

Description Vacuum cleaner  
Type designation VCE1200D/VCE2400D/VCE3600D

We declare under our sole responsibility that this product complies with the following directives and standards:

### Directives applied

2006/42/EC from 17 May 2006  
2014/30/EU from 26 February 2014

### Applied standards

EN ISO 12100:2010  
EN 60335-1:2012/A15:2022  
EN 60335-2-69:2012  
EN IEC 61000-6-2:2019  
EN IEC 61000-6-4:2019

Pfäffikon, 21.06.2022



Roland Kägi  
Operations + R & D Machines

**TYROLIT CONSTRUCTION PRODUCTS GMBH**

Swarovskistraße 33 | 6130 Schwaz | Austria

Tel +43 5242 606-0 | Fax +43 5242 63398

Our **worldwide subsidiary companies** can be found  
on our website at **[www.tyrolit.com](http://www.tyrolit.com)**