

SCANNED

749

Plant No. 05 1000 001

Brick + Mortar Arbotech Saw AS170

**ARBORTECH**<sup>TM</sup>

[www.arbortech.com.au](http://www.arbortech.com.au)

**[www.AS170.com](http://www.AS170.com)**

Arbortech Pty Ltd

Address:

67 Westchester Road  
Malaga, WA 6090

Telephone:

08 9249 1944

Australia Fax:

08 9249 2936

Email:

[arbortech@arbortech.com.au](mailto:arbortech@arbortech.com.au)

Facebook

[www.facebook.com/ArbortechTools](http://www.facebook.com/ArbortechTools)

## TABLE OF CONTENTS

	PAGE
1. INTRODUCTION	2
2. GENERAL SAFETY RULES	2
3. SPECIFIC SAFETY RULES	3-4
4. FUNCTIONAL DESCRIPTION	4
4.1 AS170 Tool Description	4
4.2 Blade Description	4
5. ASSEMBLY	5-6
6. OPERATION	7
6.1 Setup	7
6.2 Operation	7-9
7. MAINTENANCE	9
7.1 Motor	9
7.2 V-Belt and Pulleys	9-10
7.3 Blade Mount Bolts and Threads	10
7.4 Top Handle and Rubber Bushes	10
8. ACCESSORIES	10
8.1 Dust Extraction	10
9. SPECIFICATIONS	10-11
10. WARRANTY AND SERVICE	11
11. TROUBLESHOOTING	11-13

Please read these instructions before you use your AS170 Brick + Mortar Saw

## 1. INTRODUCTION

The Arbortech AS170 is designed and manufactured in Australia, using only the highest quality components and manufacturing processes. The unique patented orbital cutting action of two reciprocating blades, allows cutting of brick, mortar and masonry faster than traditional reciprocating saws.

This cutting action also produces minimal amounts of airborne dust, offering a safe and controllable operation, with the ability to cut to a depth of 170mm (6 <sup>3/4</sup>"), cut square corners, and make variable width cuts. The AS170 is ideally suited to a variety of tasks including:

- removal of mortar for "tuck pointing" of brick walls.
- removal of single bricks from walls.
- cutting of bricks without damage to adjacent areas or "blow-out" stitching, keying or toothing of brick walls "chasing" cuts for conduits and similar items into walls.
- cutting holes in walls or other surfaces.
- finishing corner cuts in walls.
- cutting in dirty wood.
- cutting wood in the ground.
- tree root removal.
- pruning trees.

**The tool can be fitted with a range of blades to best suit different applications.**

### Definitions: Safety Guidelines

The definitions below describe the level of severity for each signal word. Please read the manual and pay attention to these symbols.

- ▲ **DANGER:** Indicates an imminently hazardous situation which, if not avoided, **will** result in **death or serious injury**.
- ▲ **WARNING:** Indicates a potentially hazardous situation which, if not avoided, **could** result in **death or serious injury**.
- ▲ **CAUTION:** Indicates a potentially hazardous situation which, if not avoided, **may** result in **minor or moderate injury**.
- CAUTION:** Used without the safety alert symbol indicates a potentially hazardous situation which, if not avoided, **may** result in **property damage**.
- ▲ Denotes risk of electric shock.

▲ IMPORTANT INCORRECT USE OF THE AS170 MAY LEAD TO PREMATURE WEAR AND/OR DAMAGE. PLEASE READ THESE USER INSTRUCTIONS CAREFULLY BEFORE USE TO ENSURE CORRECT OPERATION.

## 2. GENERAL SAFETY RULES

▲ **WARNING!** Read all instructions. Failure to follow all instructions listed below may result in electric shock, fire and/or serious injury. The term "power tool" in all of the warnings listed below refers to your mains-operated (corded) power tool or battery-operated (cordless) power tool.

SAVE THESE INSTRUCTIONS

### 1) Work area

- a) **Keep work area clean and well lit.** Cluttered and dark areas invite accidents.
- b) **Do not operate power tools in explosive atmospheres, such as in the presence of flammable liquids, gases or dust.** Power tools create sparks which may ignite the dust or fumes.
- c) **Keep children and bystanders away while operating a power tool.** Distractions can cause you to lose control

### 2) Electrical safety

- a) **Power tool plugs must match the outlet. Never modify the plug in any way. Do not use any adapter plugs with earthed (grounded) power tools.** Unmodified plugs and matching outlets will reduce risk of electric shock
- b) **Avoid body contact with earthed or grounded surfaces such as pipes, radiators, ranges and refrigerators.** There is an increased risk of electric shock if your body is earthed or grounded.
- c) **Do not expose power tools to rain or wet conditions.** Water entering a power tool will increase the risk of electric shock.
- d) **Do not abuse the cord. Never use the cord for carrying, pulling or unplugging the power tool. Keep cord away from heat, oil, sharp edges or moving parts.** Damaged or entangled cords increase the risk of electric shock.
- e) **When operating a power tool outdoors, use an extension cord suitable for outdoor use.** Use of a cord suitable for outdoor use reduces the risk of electric shock.

### 3) Personal safety

- a) **Stay alert, watch what you are doing and use common sense when operating a power tool. Do not use a power tool while you are tired or under the influence of drugs, alcohol or medication.** A moment of inattention while operating power tools may result in serious personal injury.
  - b) **Use safety equipment. Always wear eye protection.** Safety equipment such as dust mask, nonskid safety shoes, hard hat, or hearing protection used for appropriate conditions will reduce personal injuries.
  - c) **Avoid accidental starting. Ensure the switch is in the off-position before plugging in.** Carrying power tools with your finger on the switch or plugging in power tools that have the switch on invites accidents.
  - d) **Remove any adjusting key or wrench before turning the power tool on.** A wrench or a key left attached to a rotating part of the power tool may result in personal injury.
  - e) **Do not overreach. Keep proper footing and balance at all times.** This enables better control of the power tool in unexpected situations.
  - f) **Dress properly. Do not wear loose clothing or jewellery. Keep your hair, clothing and gloves away from moving parts.** Loose clothes, jewellery or long hair can be caught in moving parts.
  - g) **If devices are provided for the connection of dust extraction and collection facilities, ensure these are connected and properly used.** Use of these devices can reduce dust-related hazards.
- #### 4) Power tool use and care
- a) **Do not force the power tool. Use the correct power tool for your application.** The correct power tool will do the job better and safer at the rate for which it was designed.
  - b) **Do not use the power tool if the switch does not turn it on and off.** Any power tool that cannot be controlled with the switch is dangerous and must be repaired.
  - c) **Disconnect the plug from the power source and/or the battery pack from the power tool before making any adjustments, changing accessories, or storing power tools.** Such preventive safety measures reduce the risk of starting the power tool accidentally.
- d) **Store idle power tools out of the reach of children and do not allow persons unfamiliar with the power tool or these instructions to operate the power tool.** Power tools are dangerous in the hands of untrained users.
  - e) **Maintain power tools. Check for misalignment or binding of moving parts, breakage of parts and any other condition that may affect the power tools operation. If damaged, have the power tool repaired before use.** Many accidents are caused by poorly maintained power tools.
  - f) **Keep cutting tools sharp and clean.** Properly maintained cutting tools with sharp cutting edges are less likely to bind and are easier to control.
  - g) **Use the power tool, accessories and tool bits etc. in accordance with these instructions and in the manner intended for the particular type of power tool, taking into account the working conditions and the work to be performed.** Use of the power tool for operations different from those intended could result in a hazardous situation
- #### 5) Service
- a) **Have your power tool serviced by a qualified repair person using only identical replacement parts.** This will ensure that the safety of the power tool is maintained.  
**NOTE: Refer to the assembly (section 5) for a list of user replaceable parts.**
- ### 3. SPECIFIC SAFETY RULES
1. **Hold tool by insulated gripping surfaces when performing an operation where the cutting tool may contact hidden wiring or its own cord.** Contact with a "live" wire will make exposed metal parts of the tool "live" and shock the operator.
  2. **Remove adjusting tools such as Allen & Jan keys and wrenches** before operating the tool.
  3. **Do not operate the tool with any attachment other than those recommended** in this instruction manual.
  4. **Only use the tool with the correct voltage**, as specified in the tool label.
  5. **Never start a tool under load.** Start the tool before engaging the work piece.
  6. **Never start or operate the tool with fingers or other objects through the holes in the blades.**

7. **Use care when handling blades during and after use.** The blades and some areas of the tool become hot in use.

8. **Always ensure that before cutting there are no hazards such as electrical wiring, pipes or insulation in the area to be cut.**

9. **Allow for resting periods** to ease the effect of the vibration of the tool. Use work gloves to minimise vibration effect on the body.

10. **Ensure the dust extraction equipment is connected** and properly used.

11. **Keep handles dry, clean and free from oil and grease.**

12. **If the guard or other parts appears to be damaged, it should be carefully checked** to determine that it will operate properly and perform its intended function.

13. The use of any accessory or attachment other than those recommended in this instruction manual may present a risk of personal injury.

14. **Do not force the tool.** It is designed to operate with moderate effort. Overheating of the drive system and motor can occur if the tool is overloaded.

15. **Always operate the tool holding it with both hands.**

SYMBOLS The following show the symbols used in this manual

	Class 2 Construction (Double insulation used throughout, no provision for earthing.)
VAC	volts alternating current
A	amperes
Hz	hertz
W	watt
N <sub>o</sub>	no load speed
rpm	revolutions per minute
dB	decibels
Nm	newton meters
m	meters
m/s	meters per second
mm	millimeters

SYMBOLS The following show the symbols used in this manual

kg-m	kilogram meters
ft-lb	foot pounds

## 4. FUNCTIONAL DESCRIPTION

### 4.1 AS170 Tool description

The AS170 is designed to cut rigid materials such as mortar, clay fired bricks, plasterboard, fibreboard, weatherboard and wood. The AS170 uses a variety of blades to suit the material being cut. Blades may also be changed to suit the required depth or length of cut.

The blades are driven via conrods and a camshaft, which is belt-driven. The V-belt is designed to allow some slip in case of the blades jamming. **The belt tension must be checked after the first 5 hours of use.** It is easily tightened by removing the plastic cover and its tensioned using the adjustable idler pulley (see section 7.2). Blades are mounted to the conrods using high tensile Allen™ head bolts.

A replaceable metal guard is provided to limit the maximum cutting depth and prevent the blade mounts from damaging the surface of the material being cut. Shock and vibration to the operator are reduced by a rubber-mounted top handle. The top handle is also designed for comfort when used in a variety of cutting orientations. The rubber bushes on the top handle can be replaced if they become worn or damaged.

### 4.2 BLADE DESCRIPTION

The AS170 uses a variety of blades to cut different materials and different profiles.

**General Purpose blades** use Tungsten Carbide teeth and are suited for working General masonry and "in the ground" cutting. General Purpose blades are designed to cut to a depth of 115mm (4 1/2").



**Plunge blades** use Tungsten Carbide teeth and have a maximum cutting depth of 120mm (4 3/4"). Mortar plunge blades can cut slots of 75mm (3") in length.



**Switch Box blades** use Tungsten Carbide teeth and have a maximum cutting depth of 120mm (4 3/4"). Suitable for installing small electrical switch boxes into plaster, brick/ masonry walls.

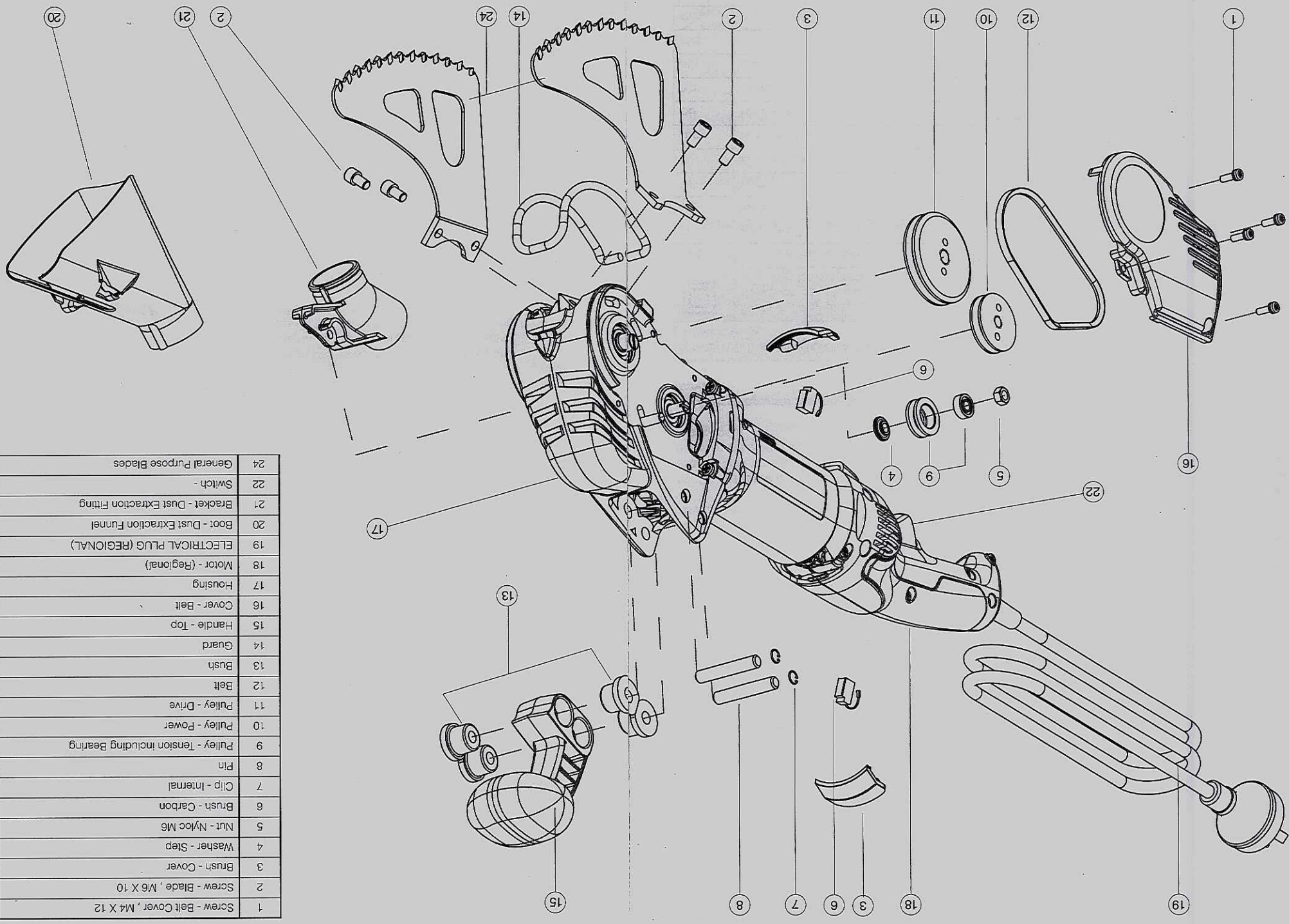

1	Screw - Belt Cover, M4 X 12	4
2	Screw - Blade, M6 X 10	4
3	Brush - Cover	2
4	Washer - Step	1
5	Nut - Nyloc M6	1
6	Brush - Carbon	2
7	Clip - Internal	2
8	Pin	2
9	Pulley - Tension including Bearing	1
10	Pulley - Power	1
11	Pulley - Drive	1
12	Belt	1
13	Bush	4
14	Guard	1
15	Handle - Top	1
16	Cover - Belt	1
17	Housing	1
18	Motor - (Regional)	1
19	ELECTRICAL PLUG (REGIONAL)	1
20	Boot - Dust Extraction Funnel	1
21	Bracket - Dust Extraction Fitting	1
22	Switch -	1
24	General Purpose Blades	1

**Heritage Blades** Ideal for mortar removal on thin joints and heritage restoration.

**Headjoint Blades** Ideal for mortar removal on vertical joints.

**XL General Purpose Blades** Cutting depth up to 170mm (6 3/4") without overcutting.

**XL Wood Blades** Efficient and safe cutting of wood and composite materials.

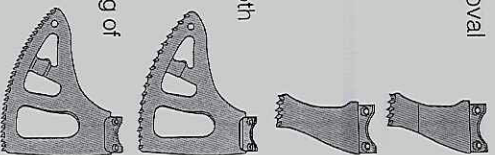

**NOTE: ALL blades can be re-sharpened. If not excessively worn.**

## 6. OPERATION

### 6.1 Setup

The AS170 is supplied ready for operation. However in some cases the blades may need to be changed to suit the application.

Before changing blades, the guard around the blade mounts must be levered gently out of its groove at the front of the tool and swung away to give access to the cap screws. (See Fig. 1)

Use the "Ian Key" supplied to loosen and remove the cap screws securing the blades, then remove the blades as shown in fig.2.

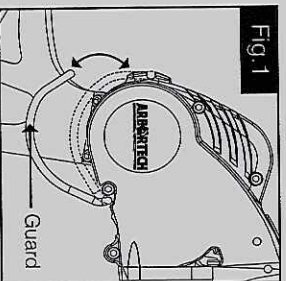

Fig 1

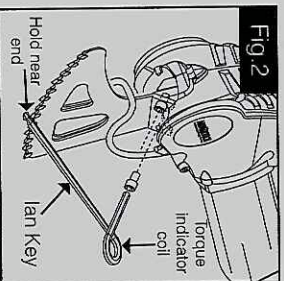

Fig 2

Select the correct blades for the cutting task and mount each with their cap screws. Verify that the surfaces of the blade mounts, conrod thread and screws are clean and free of grit or lubricant before fitting. Ensure the guard can be closed before fixing the blades to the conrod (See fig.2).

**NOTE: Always use matched pairs of blades. Never mix used blades with new blades. Use only the bolts supplied with the tool.**

Use the "Ian key" (see fig.2), to tighten the blade mounting screws until the torque indicator coil deflects sufficiently so that the sides meet. The "Ian Key" will tighten the bolts to the required 18Nm (13.2 ft lb).

**NOTE: Blades are a wearing part. In normal operation, blade life may vary with the hardness of materials cut.**

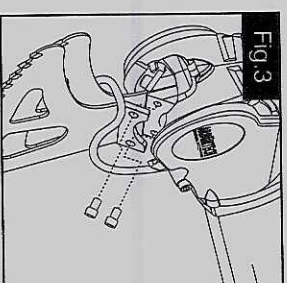

Fig 3

### CAUTION:

Do not operate the tool if the blades are loose. Operation with loose blades will severely damage the blade mount & bolts requiring repair. Check that the teeth of the blades are lightly contacting, or within approximately 1.5mm (1/16") of contacting each other (fig.4).

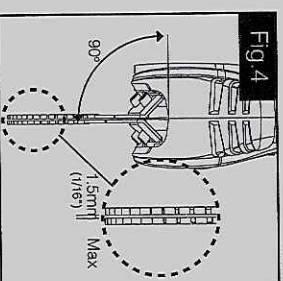

Fig 4

If the gap between the blades is too large, remove and gently bent inward to adjust the gap. Ensure that both blades are aligned vertically to the tool (See fig.4).

**CAUTION:** If the blades rub against each other anywhere other than within 25mm/1" of the cutting edge, or contact force is high, it is possible to overload the tool and cause premature belt wear. Swing the guard to its groove at the front of the tool and snap it into place. (See fig. 1)

### 6.2 Operation

**CAUTION:** During operation the AS 170 may cause hand-arm vibration, which can result in fatigue or discomfort after long periods of continuous use. Vibration will increase with the hardness of material.

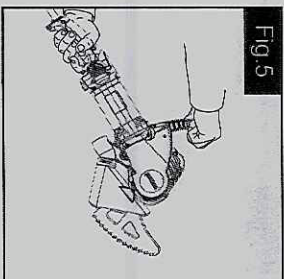

Fig. 5

Do not operate the tool if discomfort is experienced, and ensure that sufficient rest periods are taken during cutting. For further information, contact the manufacturer.

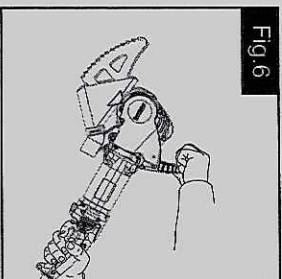

Fig. 6

Before attempting to operate the tool, please ensure that the safety section of this manual has been consulted.

Apply protective hearing, breathing, eyes and body protection as appropriate.

With the blades secured and the tool switch OFF, plug the tool into the power socket.

Fig. 7

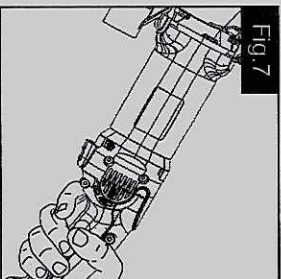

**CAUTION:** Do not block the cooling intake vents or ingest dust or debris at the rear of the motor as this may cause the motor to overheat. If working in dusty conditions, it is recommended that the vents be regularly cleaned with an air blast. (See fig. 7)

Hold the tool by both the top handle and the motor housing. (Fig. 5 & 6)

To start the cut, hold the tool firmly in your hands and apply the middle of the blade cutting edge to the work, keeping in mind that the direction of cut is towards the rear of the blades.

While cutting, move the tool and blade in a slow "sawing" motion, which improves the cut rate, reduces concentrated heat build-up and evens the wear on the blades. (See fig. 8 & 9)

Direction of cut  
↓

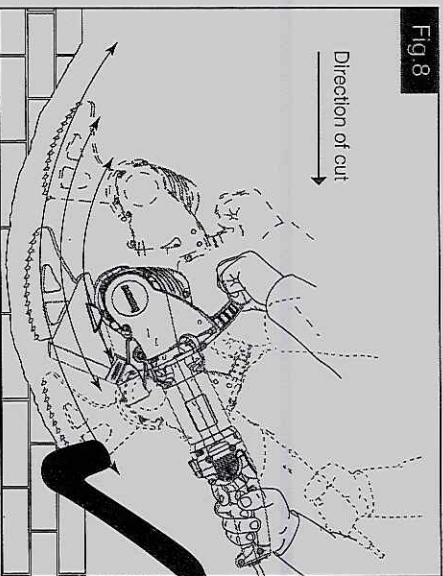
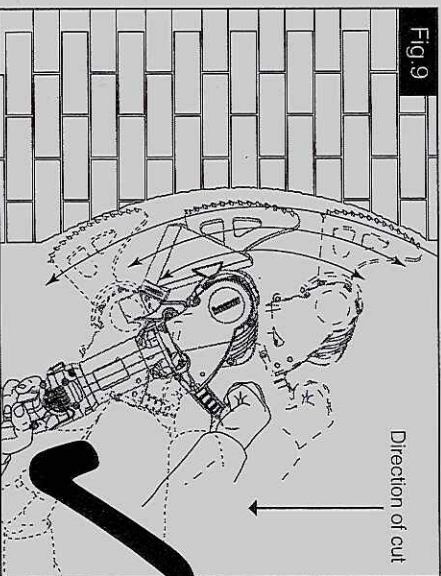

Fig. 8

Fig. 9



**CAUTION:** Do Not allow the forward or rear end of the blades to hammer onto hard surfaces (shown in figs: 10, 11 & 13) as this will damage the blades and tool. If unintentional hammering occurs, stop the tool or withdraw it from the cut immediately.

When using any of the blade types, avoid hammering of the ends of the blades into the ends of the cut by using a slow rocking and sweeping motion. For best performance try to ensure that the teeth are the only part of the blade in contact with the workpiece.

**CAUTION:** Take care when setting the tool down to avoid chipping the tungsten carbide teeth.

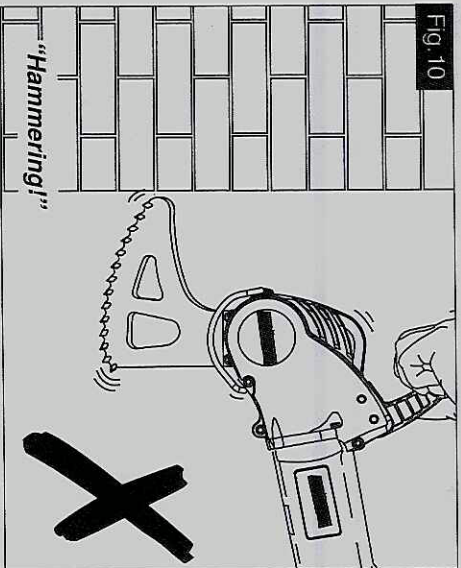

Fig. 10

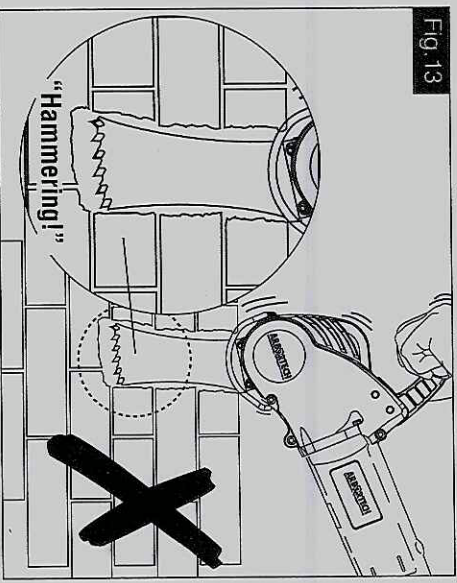

Fig. 13

## 7. MAINTENANCE

**⚠ WARNING:** To reduce the risk of serious personal injury, turn the tool off and disconnect tool from the power source before making any adjustments or removing/installing attachments or accessories.

Before reconnecting the tool, depress and release the trigger switch to ensure that the tool is turned off.

To assure product **SAFETY** and **RELIABILITY**, repairs, maintenance and adjustment (including brush inspection and replacement) should be performed by an ARBORTECH authorised service center. Always use identical replacement parts.

### 7.1 Motor

#### Cleaning

**CAUTION:** Blowing dust and grit out of the motor and switch actuator using clean, dry compressed air is a necessary regular maintenance procedure. Dust and grit particles often accumulate on interior surfaces and can cause premature failure. Not regularly cleaning the AS-170 will affect the tools warranty.

**⚠ CAUTION:** ALWAYS WEAR SAFETY GLASSES when using or cleaning this tool.

Never use solvents or other harsh chemicals for cleaning the non-metallic parts of the tool. Use a clean, dry cloth only.

#### Lubrication

ARBORTECH tools are properly lubricated at the factory and are ready for use.

#### Accessories

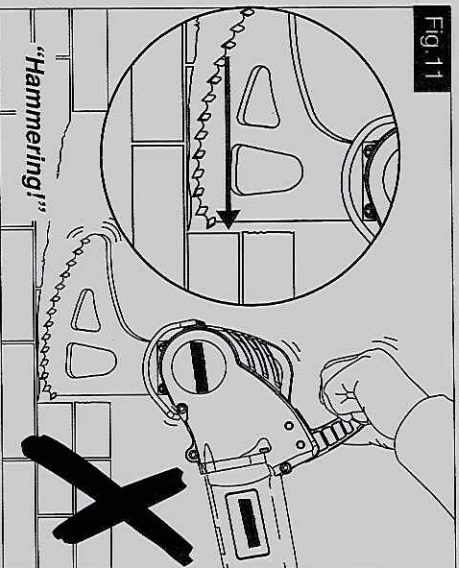

Fig. 11

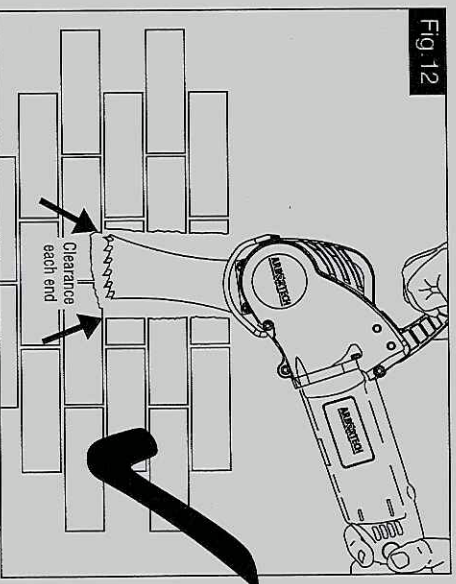

Fig. 12

When using the Mortar Plunge blades, the cut should have enough clearance on each end (shown in fig. 12), to ensure that no hammering of the blade ends occurs (as shown in fig. 13).

To reduce the risk of injury, only ARBORTECH accessories should be used with this product. Recommended accessories for use with your tool are available at extra cost from your local dealer or authorised service centre.

## Repairs

If you need any assistance in locating any accessory, or general tool query please contact ARBORTECH, [www.arbortech.com.au](http://www.arbortech.com.au)

## Brushes

The AS170 is fitted with Auto-cut off brushes. When the brushes are worn below minimum length they stop tool operation reducing internal motor damage. Contact your local dealer or authorised service center for brush replacement.

## 7.2 V Belt and Pulleys

**CAUTION:** The V-Belt should be re-tensioned after the first 5 hours of use.

To access these items, remove the 4 screws holding the plastic cover on the right side of the tool (see fig. 14). Inspect the belt for correct tension and signs of damage. If tensioning is required, loosen the tension idler nut (one turn only). Slide the tension idler outward to increase the tension to the value noted in the **General Specifications** in Section 3 and re-tighten. If belt replacement is required, loosen the tensioner idler, replace the belt and re-tension the idler as specified.

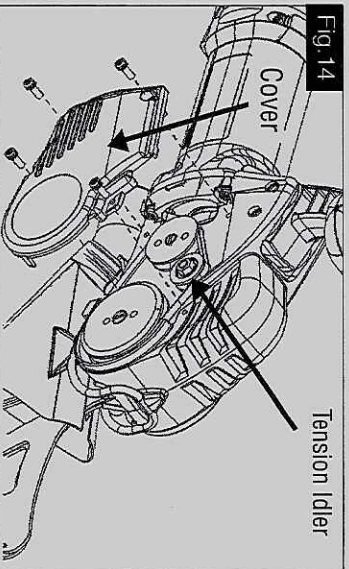

If excessive slipping has occurred, the pulleys can become worn. A worn pulley is evidenced by the groove having lost its well defined "V" shape, resulting in a rounded or flattened groove. To replace either pulley, contact your ARBORTECH authorised service centre.

## 7.3 Blade Mount Bolts and Threads

The blade cap screws should be regularly checked

for correct torque (18Nm,)(13.2 ft.lb). Whenever blades are changed, the bolt and conrod threads should be checked to ensure they are not worn or filled with debris. Use only genuine ARBORTECH spares and do not lubricate bolts, threads or conrod mating surfaces.

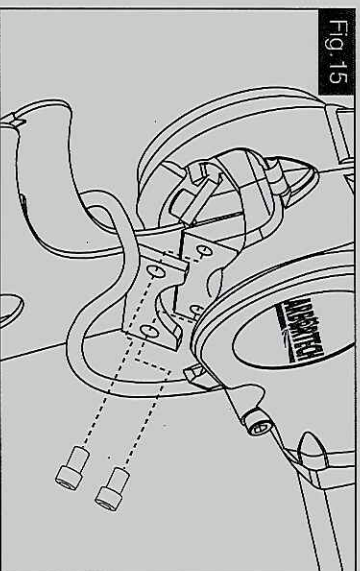

**CAUTION:** DO NOT operate the tool with loose blades. If blades should come loose while operating, the blade mounts and threads can become damaged, requiring significant repairs to the tool.

## 7.4 Tooth Sharpness

With use, the blades will become dull and the cutting performance will decrease. This can be largely restored by re-sharpening the teeth. To re-sharpen blade teeth, use the ARBORTECH Sharpening disk (BLA.FG.SHARP001) Occasionally, if very hard materials are cut, or the teeth impact a hard surface at an odd angle, teeth may become chipped or broken. The blades can still be used, but cutting performance will be reduced.

If "Bluing" of the blade periphery occurs, the blades are running too hot. This occurs when the blades become worn, too much force being used, insufficient "sweeping" motion by the operator, or material being too hard.

**IMPORTANT** To ensure optimal performance and reduce load on motor, Blades should be kept sharp.

## 8. ACCESSORIES

### 8.1 Dust Extraction

The AS170 should be fitted with a dust extraction funnel, which significantly reduces airborne and heavy dust when used correctly. It consists of a fitting attached to the underside of the aluminium housing and an adjustable extraction funnel which is replaceable. The dust extraction fitting has a standard 30mm (1 3/16") bore.

**NOTE:** Failure to use the dust extraction funnel when cutting masonry materials will cause excessive wear of electrical components. Damage caused by dust will lead to premature failure of the motor, which will affect the warranty.

**CAUTION:** Verify that the vacuum machine being used has a filter system appropriate for the material being cut. Incorrect filtration can result in inadequate dust control and also possible damage to the vacuum machine.

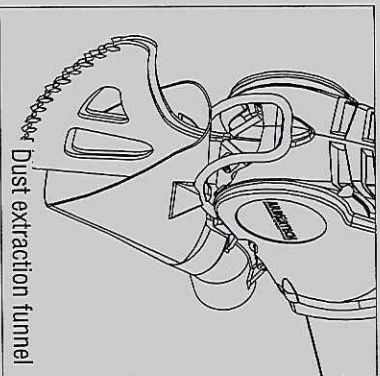

## 9. SPECIFICATIONS

ITEM	SPECIFICATION
Cutting depth/width	170mm (6 3/4")/6.5mm (1/4"), depending on blade
Weight, with cutting blades	4.3kg (9.5lb)
Dimensions without blades	450 mm (17 11/16") L 75 mm (3") W 240 mm (9 7/16") H
No load speed $n_0$	5100 rpm
Electrical rating, nominal	230-240 VAC, 50HZ,

## ITEM

## SPECIFICATION

Dust extraction vacuum hose interface	Suits vacuum hose with inner diameter of 25mm, 32mm, 37mm or outer hose diameter 32mm
Belt tension	1.5mm (1/16") maximum mid-span deflection with 25 N (2.5 kg) (5lb) deflection force
Blade mount bolt torque	18 Nm (1.8 kg-m), (13.2ft-lb),

## 10. WARRANTY AND SERVICE

For warranty repair, inspection, service and spare parts, please contact your place of purchase, or

Contact us directly at:

ARBORTECH PTY LTD  
67 WESTCHESTER ROAD, MALAGA, PERTH  
WESTERN AUSTRALIA • 6090  
T: 08 9249 1944  
Fax: 08 9249 2936  
www.arbortech.com.au  
E: arbortech@arbortech.com.au

## 11. TROUBLESHOOTING

This fault diagnosis is intended for use by persons familiar with mechanical devices, and provides a basic capability to maintain the tool. To correct the user serviceable faults, refer to the Maintenance section of this manual. The more complex repairs as noted below, must be performed by an authorised

ITEM	SYMPTOM	CHECK/REMEDY
1	Motor overheating	<ul style="list-style-type: none"> <li>• Verify that all cooling vents are not obstructed by operators hand, debris in vents, or other. Remedy or clean as required.</li> <li>• Verify blades are not rubbing against each other with excessive force, either at cutting edge or close to blade mounts.</li> <li>• Blades may be worn and overheating. Replace as required.</li> <li>• Check that belt tension is not excessive.</li> <li>• Check that bearings have not failed by removing plastic side cover and belt and rotating both pulleys independently checking for roughness. The power pulley should rotate easily and smoothly. The driven pulley should rotate smoothly but will have a "springy" feel, wanting to stay in either of 2 positions.</li> <li>• Verify that the motor housing is secure with the tool. If loose, refer to authorised service centre immediately.</li> </ul>
2	Noisy operation or unusual vibration	<ul style="list-style-type: none"> <li>• Blades loose - tighten blade mount bolts</li> <li>• Blade failure - replace blade set</li> <li>• Leaf spring failure - contact authorised service centre</li> <li>• Bearing failure - contact authorised service centre.</li> <li>• Gearbox failure - contact authorised service centre.</li> <li>• Handle rubber mounts damaged or worn - replace.</li> </ul>
3	Handle rubber mounts damaged or worn	<ul style="list-style-type: none"> <li>• replace</li> </ul>
4	One or both conrods/blades loose, even when mounting bolts tightened	<ul style="list-style-type: none"> <li>• Leaf spring failure - contact ARBORTECH authorised service centre.</li> </ul>
5	Tool running and blades not moving	<ul style="list-style-type: none"> <li>• Loose belt or broken belt- re-tension or replace as necessary.</li> <li>• Worn belt - replace belt.</li> </ul>
7	Blades continually coming loose	<ul style="list-style-type: none"> <li>• Check the blade bolt holes. If bolt holes are elongated replace blades</li> </ul>
8	Worn pulleys	<ul style="list-style-type: none"> <li>• contact ARBORTECH authorised service centre.</li> </ul>
9	Slow cutting performance	<ul style="list-style-type: none"> <li>• Teeth worn, chipped or lost. Sharpen or replace blade.</li> <li>• Belt slipping - see Symptom 4.</li> </ul>
10	Blades rubbing against each other with excessive force	<ul style="list-style-type: none"> <li>• Attempting to cut material which is too hard.</li> </ul>
11	Blades continually coming loose	<ul style="list-style-type: none"> <li>• Check the blade bolt holes. If bolt holes are elongated replace blades.</li> </ul>
12	Blades rubbing together with excessive force.	<ul style="list-style-type: none"> <li>• Remove blades and bend slightly to correct.</li> </ul>

ITEM	SYMPTOM	CHECK/REMEDY
13	Blade teeth chipped or lost.	<ul style="list-style-type: none"> <li>• Occurs occasionally if hard material is encountered, or if the "back side" of teeth are impacted.</li> <li>• Care not taken in setting tool down on teeth on hard surfaces or loose in tool box.</li> <li>• Worn blades will start to become hot in certain areas, causing teeth to de-bond - replace blades.</li> <li>• Material too hard.</li> </ul>
14	Loose top handle.	<ul style="list-style-type: none"> <li>• Worn or damaged rubber bushes - replace.</li> </ul>
15	Blades "blueing".	<ul style="list-style-type: none"> <li>• Worn teeth - replace blades.</li> <li>• Excessive force being used.</li> <li>• Insufficient "sawing" motion by the operator.</li> <li>• Material too hard.</li> </ul> Blades rubbing together with excessive force (see section 8).
16	Blade mounting bolts not tightening fully.	<ul style="list-style-type: none"> <li>• Threads on bolts stripped - replace bolts not tightening.</li> </ul>
17	Threads on tool stripped	<ul style="list-style-type: none"> <li>• Contact your ARBORTECH authorized service center.</li> </ul>
18	Tool will not run.	<ul style="list-style-type: none"> <li>• The AS170 is fitted with Auto cut off brushes.</li> <li>• Check brushes are not damaged or excessively worn - replace</li> <li>• Contact your ARBORTECH authorised service centre.</li> </ul>