

# KEY TO SYMBOLS

## Key to symbols

**WARNING!** The machine can be a dangerous tool if used incorrectly or carelessly, which can cause serious or fatal injury to the operator or others.



Please read the operator's manual carefully and make sure you understand the instructions before using the machine.



Always wear:

- Approved protective helmet
- Approved hearing protection
- Protective goggles or a visor



Rating plate



This product is in accordance with applicable EC directives.



**WARNING!** Dust forms when cutting, which can cause injuries if inhaled. Use an approved breathing mask. Always provide for good ventilation.



**WARNING!** Sparks from the cutting blade can cause fire in combustible materials such as: petrol (gas), wood, dry grass etc.



Noise emission to the environment according to the European Community's Directive. The machine's emission is specified in chapter Technical data and on label.

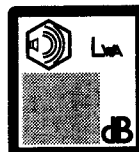

**Other symbols/decals on the machine refer to special certification requirements for certain markets.**

Inspection and/or maintenance should be carried out with the motor switched off and the plug disconnected.

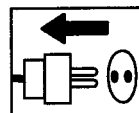

Always wear approved protective gloves.

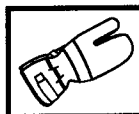

Regular cleaning is required.

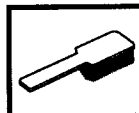

Visual check.



Protective goggles or a visor must be worn.



## Steps before using a new power cutter.

- Please read the operator's manual carefully.
- Check the cutting blades mounting, see the chapter "Assembly".
- Check that the cord and extension cord are intact and in good condition.
- Do not use a rolled up extension cord

Let your Partner dealer check the power cutter and make essential adjustments and repairs.

**WARNING!** Under no circumstances may the design of the machine be modified without the permission of the manufacturer. Always use genuine accessories. Non-authorized modifications and/or accessories can result in serious personal injury or the death of the operator or others.

**WARNING!** Use of products which cut, grind, drill, sand or shape material can generate dust and vapors which may contain harmful chemicals. Know the nature of the material being worked on and wear appropriate dust mask or respirator protection.

# CONTENTS

## Contents

### KEY TO SYMBOLS

Key to symbols .....	2
Steps before using a new power cutter. ....	2

### CONTENTS

Contents .....	3
----------------	---

### SAFETY INSTRUCTIONS

Personal protective equipment .....	4
Machine's safety equipment .....	4
Checking, maintaining and servicing the machine's safety equipment .....	5
General safety precautions .....	5
General working instructions .....	6
Cutting blades .....	8

### WHAT IS WHAT?

What is what on the power cutter? .....	10
-----------------------------------------	----

### ASSEMBLY

Fitting the cutting blade .....	11
Blade guard .....	11

### STARTING AND STOPPING

Starting and stopping .....	12
-----------------------------	----

### MAINTENANCE

Maintenance .....	13
-------------------	----

### TECHNICAL DATA

Cutting equipment .....	15
EC-declaration of conformity .....	15

# SAFETY INSTRUCTIONS

## Personal protective equipment

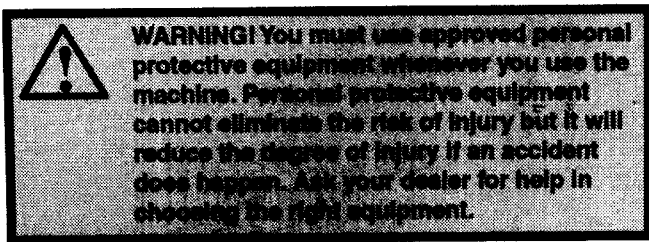

- Protective helmet
- Hearing protection
- Protective glasses or a full face guard



- Breathing mask

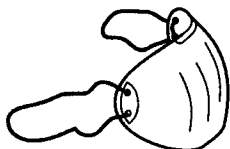

- Heavy-duty, firm grip gloves.



- Tight-fitting, heavy-duty and comfortable clothing that permits full freedom of movement.
- Leg protection (to protection against sparks and cutting tools).



- Boots with steel toe-caps and non-slip sole



- Always have a first aid kit nearby.

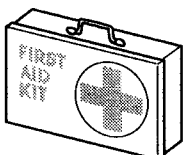

## Machine's safety equipment

This section describes the machine's safety equipment, its purpose, and how checks and maintenance should be carried out to ensure that it operates correctly. See the "What is what?" section to locate where this equipment is positioned on your machine.

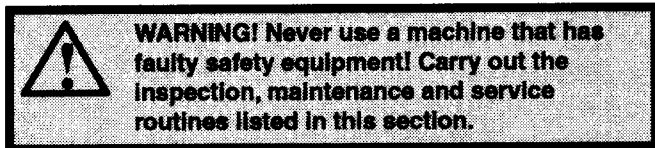

### Switch

The power switch should be used to start and stop the machine.

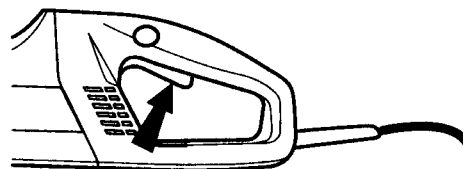

### Power switch lock

The power switch lock is designed to prevent accidental operation of the switch. When the lock (A) is pressed in the power switch (B) is released.

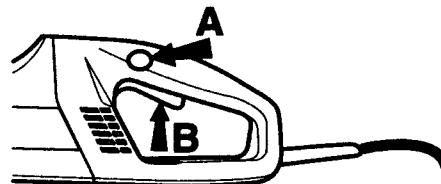

The power switch lock remains depressed as long as the power switch is depressed.

When the grip on the handle is released both the power switch and power switch lock are reset. This movement is controlled by two independent return springs. This position results in the machine stopping and the power switch being locked.

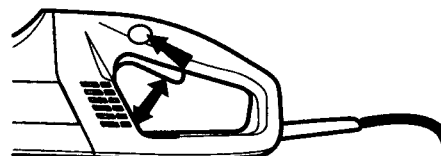

### Guard for the cutting blade

This guard is fitted above the cutting blade and is designed to prevent parts of the blade or cutting fragments from being thrown towards the user.

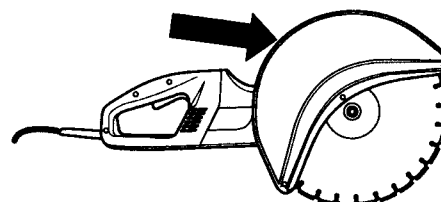

# SAFETY INSTRUCTIONS

## Checking, maintaining and servicing the machine's safety equipment



**WARNING!** All servicing and repair work on the machine requires special training. This is especially true of the machine's safety equipment. If your machine falls any of the checks described below you must contact your service agent. When you buy any of our products we guarantee the availability of professional repairs and service. If the retailer who sells your machine is not a servicing dealer, ask him for the address of your nearest service agent.

### Checking the power switch

Start the machine, release the power switch and check that the engine and the cutting blade stop.

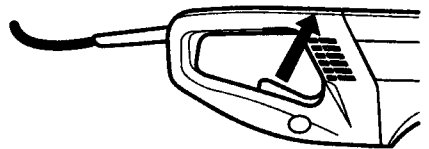

A defective power switch should be replaced by an authorized service workshop

### Checking the power switch lock

Make sure the power switch is locked when the power switch lock is in its original position.

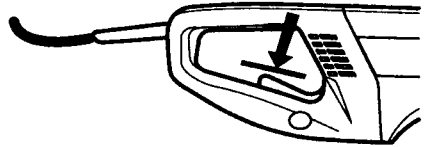

Press in the power switch lock and make sure it returns to its original position when you release it.

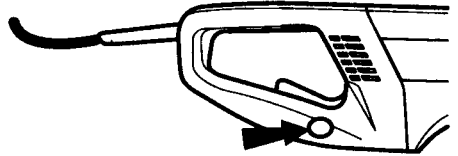

Check that the power switch and power switch lock move freely and that the return springs work properly.

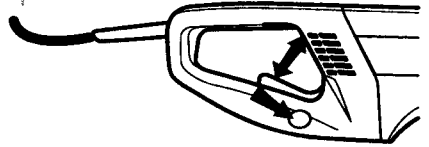

Start the machine, release the power switch and check that the engine and the cutting blade stop.

## General safety precautions

- A power cutter is designed to cut hard materials such as concrete/stone and steel/iron. Observe the increased risk of kickback when cutting soft materials. See instructions under the heading How to avoid kickback.
- Do not use the power cutter until you have read the entire contents of this Operator's Manual.
- All servicing, in addition to the points listed in the section "Control, maintenance and service of the power cutter's safety equipment", should be carried out by trained service specialists.
- Never use the machine if you are tired, if you have drunk alcohol, or if you are taking medication that could affect your vision, your judgement or your co-ordination.
- Wear personal protective equipment. See instructions under the heading Personal protective equipment.
- Never use a machine that has been modified in any way from its original specification.
- Do not use the machine in wet or humid surroundings, close to water, in the rain or snow. Dampness can cause short circuiting.
- Be on your guard for electrical shocks. Avoid having body contact with lightning-conductors/metal in the ground.
- Never carry the machine by means of the cord and never pull out the plug by pulling the cord. Keep all cords and extension cords away from water, oil and sharp edges. Make sure the cord is not pinched in doors, fences or the like. Otherwise it can cause the object to become live.
- Check that the cord and extension cord are intact and in good condition. Never use the machine if the cord is damaged, hand it in to an authorized service workshop for repair.

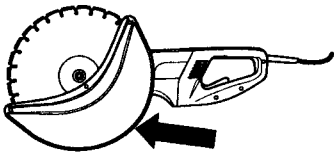

Check that the guard is intact and that the material is not cracked or deformed.

**WARNING!** Check that the cutting blade is fitted correctly and does not show signs of damage. A damaged cutting blade can cause personal injury. See instructions under the heading Assembly.

**WARNING!** Always check that the blade guard is correctly fitted before starting the machine. See instructions under the heading Assembly.

Inspection of the guard for the cutting blade

# SAFETY INSTRUCTIONS

- Do not use a rolled up extension cord

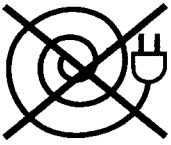

- The machine should be connected to an earthed outlet socket.
- Check that the mains voltage corresponds with that stated on the rating plate on the machine.
- Never use a machine that is faulty. Carry out the checks, maintenance and service instructions described in this manual. Some maintenance and service measures must be carried out by trained and qualified specialists. See instructions under the heading Maintenance.
- Never allow anyone else to use the machine without first ensuring that they have understood the contents of the operator's manual.

## Transport and storage

Do not store or transport the power cutter with the cutting blade fitted.

Store the power cutter in a lockable area so that it is out of reach of children and unauthorised persons.

All blades should be removed from the cutter after use and stored carefully. Store cutting blades in dry, frost free conditions.

Special care should be taken with abrasive discs. Abrasive discs must be stored on a flat, level surface. If blades are supplied with a backing pad then a spacer should be used to keep them flat.

If an abrasive disc is stored in humid conditions, this can cause imbalance resulting in injury.

Inspect new blades for transport or storage damage.

## General working instructions



**WARNING!** This section describes basic safety directions for using a power cutter. This information is never a substitute for professional skills and experience. If you get into a situation where you feel unsafe, stop and seek expert advice. Contact your dealer, service agent or an experienced power cutter user. Do not attempt any task that you feel unsure of!

### Basic safety rules

- Look around you:
  - To ensure that people, animals or other things cannot affect your control of the machine.
  - To make sure that none of the above come into contact with the cutting blade.

- Do not use the machine in bad weather, such as dense fog, rain, strong wind, intense cold, etc. Working in bad weather is tiring and can lead to dangerous conditions, e.g. slippery surfaces.
- Never start to work with the power cutter before the working area is clear and you have a firm foothold. Look out for any obstacles with unexpected movement. Ensure when cutting that no material can become loose and fall, causing operating injury. Take great care when working on sloping ground.
- Make sure clothing and parts of the body do not come into contact with the cutting blade when the engine is started.
- Maintain a safe distance from the cutting blade when the engine is running.
- The blade guard should always be fitted when the engine is running.
- Ensure that the working area is sufficiently illuminated to create a safe working environment.
- Do not move the power cutter with the blade rotating.
- Always ensure you have a safe and stable working position
- Make sure that no pipes or electrical cables are routed in the area to be cut.
- Ensure the cord is behind you when you start to use the machine so that the cord will not be damaged.
- The machine should be connected to an earthed outlet socket.

## Cutting



**WARNING!** The safety distance for the power cutter is 15 metre. You are responsible that animals and onlookers are not in the working area. Do not start to work with the power cutter before the working area is clear and you have a firm foothold.

### General

- Start cutting with the engine at full throttle.
- Always hold the power cutter in a firm grip with both hands. Hold the machine so that the thumb and fingers grip around the handle.

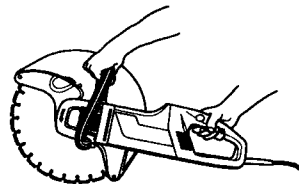

# SAFETY INSTRUCTIONS

**WARNING!** Overexposure to vibration can lead to circulatory damage or nerve damage in people who have impaired circulation. Contact your doctor if you experience symptoms of overexposure to vibration. These symptoms include numbness, loss of feeling, tingling, pricking, pain, loss of strength, changes in skin colour or condition. These symptoms normally appear in the fingers, hands or wrists.



## Cutting technique

The technique described below is of a general character. Check information for each blade regarding individual cutting characteristics (for example, a diamond blade requires less feeding pressure than an abrasive disc).

- Support the work piece in such a way that you can predict what will happen and so it will not pinch.

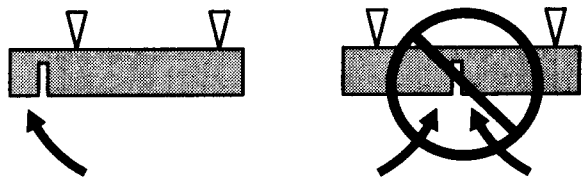

- Check that the blade is not in contact with anything when the machine is started.

- Always cut at full throttle.

- Start cutting gently, do not force or squeeze the blade in.

- Move the blade slowly backwards and forwards.

Use a small part of the blade's cutting edge.



- Cut with the blade fully vertical – at right angles to the work piece.

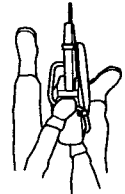

- The guard should be adjusted so that the rear section rests against the work piece. Abrasive particles and sparks are then collected by the guard and led away from the user.

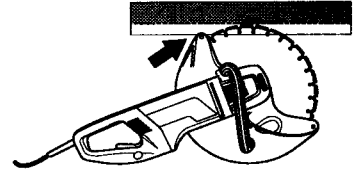

## Sharpening diamond blades

Diamond blades can become dull when the wrong feeding pressure is used or when cutting certain materials such as heavily reinforced concrete. Working with a dull blade causes overheating and finally the loss of a segment (part of a cutting blade).

Sharpen against a soft material such as sandstone or brick.

## Blade vibration

The blade can become out of shape (not round) and vibrate if a too high feeding pressure is used or if the blade is pressed into the work piece.

A lower feeding pressure ought to stop the vibration. Otherwise replace the cutting blade.

## How to avoid kickback



**WARNING!** Kickback can happen very suddenly and violently; kicking the power cutter and cutting blade back at the user. If this happens when the cutting blade is moving it can cause very serious, even fatal injuries. It is vital you understand what causes kickback and that you can avoid it by taking care and using the right working technique.

## What is kickback?

The word kickback is used to describe the sudden reaction that causes the power cutter and cutting blade to be thrown from an object when the upper quadrant of the blade, known as the kickback zone, touches an object.

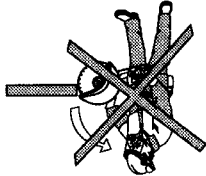

Kickback only occurs when the cutting blades kickback zone touches an object.

## General rules

- Never cut with the cutting blades upper quadrant, i.e. the kickback zone.

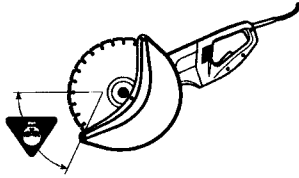

# SAFETY INSTRUCTIONS

- Always hold the power cutter in a firm grip with both hands. Hold the machine so that the thumb and fingers grip around the handle.

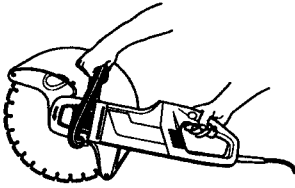

- Keep a good balance and a firm foothold.
- Always cut at full throttle.
- Stand at a comfortable distance from the work piece.
- Take care when inserting the blade in an existing cut.
- Never cut above shoulder height.
- Be alert to movement of the work piece or anything else that can occur, which could cause the cut to close and pinch the blade.

## Pull in

Pull in occurs when the discs lower section suddenly stops or when the cut closes. (To avoid, see the heading "Basic rules" and "Jamming/rotation", here below.)

## Pinching/rotation

Pinching occurs when the cut closes. The power cutter can be pulled down suddenly with a very powerful movement.

## How to avoid pinching

Support the work piece in such a way that the cut remains open during the cutting operation and when the cut is finished.

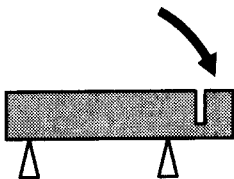

## Cutting blades



**WARNING! A cutting blade may burst and cause injury to the operator.**

**Never use a cutting blade at a lower speed rating than that of the power cutter.**

**Never use a cutting blade for any other materials than that it was intended for.**

The machine must not be used with a rescue blade. The risk of kick-back is greater with this type of cutting blade, as the machine does not have a slipping clutch.

## General

Cutting blades are available in two basic designs; abrasive discs and diamond blades.

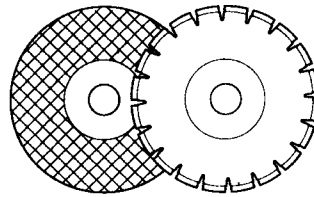

Always remove the cutting blade when the machine is transported.

Make sure that the right bushing is used for the cutting blade to be fitted on the machine. See the instructions under the heading Assembling the cutting blade.

## High speed portable tools

Our cutting blades are manufactured for high-speed, portable power cutters. If blades from other manufacturers are used, ensure that the blades conform to all regulations and demands that concern this type of power cutter.

## Special blades

Some cutting blades are designed for stationary equipment and for use with attachments. Such cutting blades must not be used on portable power cutters.

Always contact local authorities and make sure you are following applicable directives.

## Abrasive discs

The cutting material on abrasive discs consists of grit bonded using an organic binder. "Reinforced blades" are made up of a fabric or fibre base that prevents total breakage at maximum working speed if the blade should be cracked or damaged. (The term reinforced does not refer to those cutting blades that are only reinforced around the flange).

A cutting blade's performance is determined by the type and size of abrasive corn, and the type and hardness of the bonding agent.

Characteristics that give the blade a shorter service life and greater cutting capacity are said to make the blade "softer". A blade with a longer service life and slower cutting capacity is a blade with a "harder" effect.

High quality cutting blades are normally more economical. Lower quality cutting blades usually have an inferior cutting capacity and shorter service life, which results in higher cost per processed material.

# SAFETY INSTRUCTIONS

Abrasive discs, types and use	
Intended Use	Material
<b>Disc type</b>	<b>General properties</b>
Concrete	Universal use, economy, stone masonry, cast concrete, asphalt, iron, aluminium, copper, brass, cables, rubber, plastic, etc.
Metal	Unrivalled for steel (does not work well on materials like concrete), Steel, steel alloys and other hard metals.

Check that the blade is approved for the same or higher speed according to the approval plate of the engine. Never use a cutting blade with a lower speed rating than that of the power cutter.

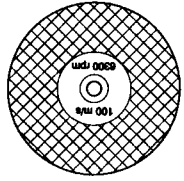

Ensure the blade is not cracked or damaged in any other way.

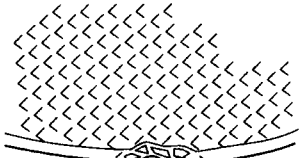

Test the abrasive disc by hitting it lightly with a piece of wood. If the blade does not give a full-sounding ring then it is damaged.

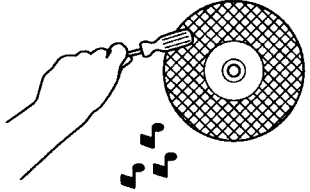

## Diamond blades

Diamond blades for dry cutting are a new generation of blades that do not require water cooling. However, the blades are still damaged by excessive heat. It is good economics to let the blade cool by simply lifting the blade from the cut every 30-60 seconds and let it rotate in the air, for 10 seconds to cool.

Always use a sharp diamond blade.

## General properties

Diamond blades give a lower cost per cutting operation, less blade replacement, constant cutting depth and less dust.

When using diamond blades make sure that it rotates in the direction indicated by the arrow on the blade.

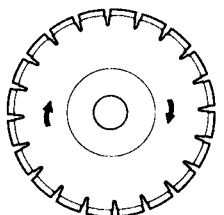

There is an arrow on the rear of the machine that indicates the axes direction of rotation that the disc is mounted on.

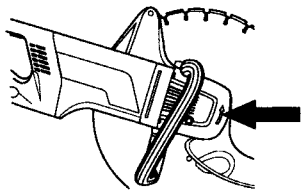

## Material

Diamond blades are ideal for masonry, reinforced concrete and other composite materials. Diamond blades are not recommended for cutting metal.

# WHAT IS WHAT?

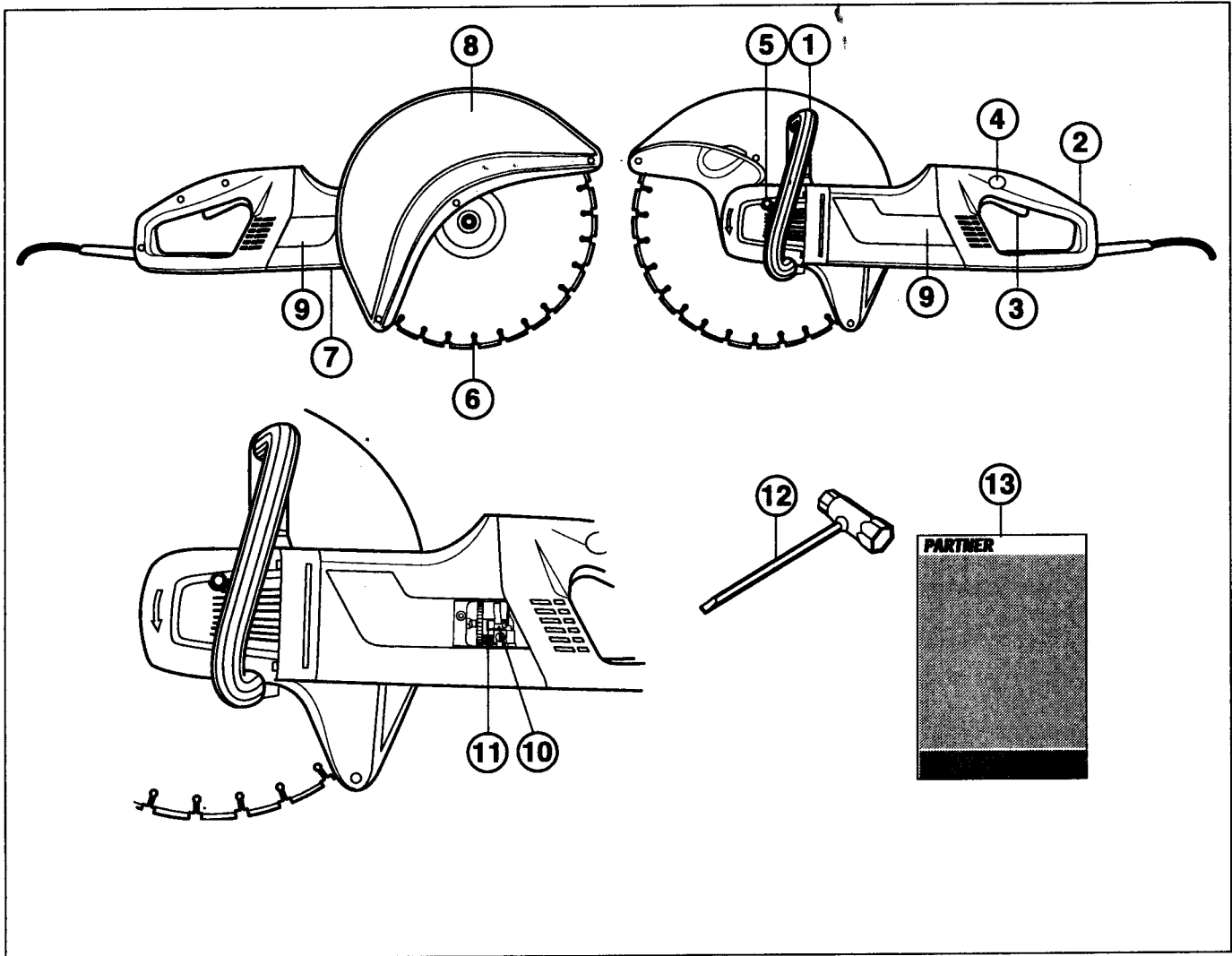

## What is what on the power cutter?

- |                     |                        |
|---------------------|------------------------|
| 1 Front handle      | 8 Blade guard          |
| 2 Rear handle       | 9 Inspection covers    |
| 3 Switch            | 10 Carbon brushes      |
| 4 Power switch lock | 11 Brush retainer      |
| 5 Locking the axle  | 12 Combination spanner |
| 6 Cutting blade     | 13 Operator's manual   |
| 7 Rating plate      |                        |

There is an arrow on the rear of the machine that indicates the axes direction of rotation that the disc is mounted on.

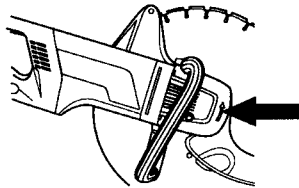

When the cutting blade is replaced with a new blade check the flanges and drive axle, see the instructions under the heading Checking the drive axes and flanges.

### Checking the drive shaft and flanges



Check that the threads on the drive shaft are undamaged.

Check that the contact surfaces of the cutting blade and flanges are flat, run correctly on the spindle and are free from

foreign objects.

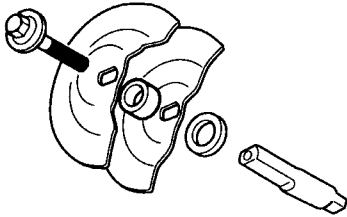

Do not use flanges that are twisted, have damaged edges, untrue or dirty. Do not use different size flanges..

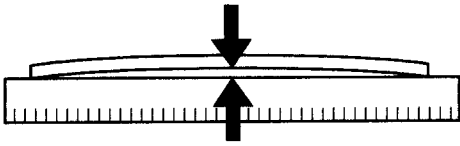

### Blade guard

The blade guard should always be fitted on the machine.

The guard should be adjusted so that the rear section rests against the work piece. Abrasive particles and sparks are then collected by the guard and led away from the user.

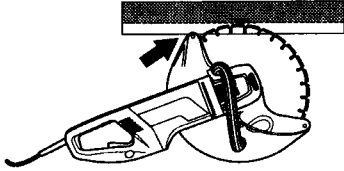

**WARNING!** Always pull out the plug from the outlet socket before cleaning, maintenance or assembly.



### Fitting the cutting blade



Fit the right bushing on the drive axle and then the cutting blade on the bushing.

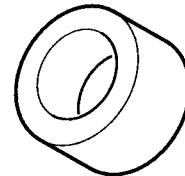

Different cutting blades have different inside measurements, which is why different bushings must be used. Ensure that the bushing to be used has the outside diameter intended for the cutting blades inner diameter. The inner diameter measurement is marked on the cutting blade.

The blade is placed between the flange hub (A) and the flange washer (B). The flange washer is turned so that it fits on the axle.

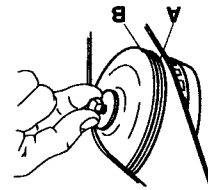

Tightening torque for the bolt holding the blade is: 15-25 Nm (130-215 in.lb).

The cutting blade/axle can be locked by holding in the locking button on the rear of the machine. The button is spring-loaded and is reset when button is released.

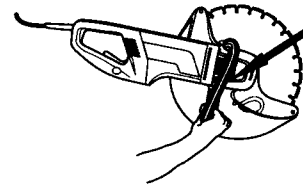

When a diamond blade is mounted on the power cutter make sure that the diamond blade will rotate in the direction indicated by the arrow on the blade.

# STARTING AND STOPPING

## Starting and stopping



**WARNING!** Note the following before starting:

The machine should be connected to an earthed outlet socket.

Check that the mains voltage corresponds with that stated on the rating plate on the machine.

Make sure you have a secure footing and that the cutting blade cannot touch anything.

Keep people and animals well away from the working area.

## Starting

- Grip the front handle with your left hand.

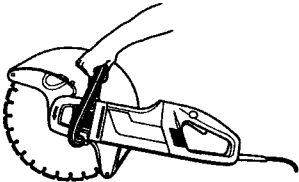

- Grip the rear handle with your right hand.

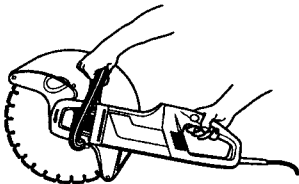

- Press in the power switch lock with your right-hand thumb and press in the power switch.

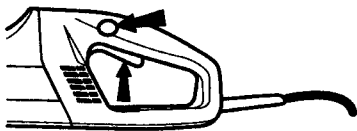

## Stopping

Stop the motor by releasing the power switch

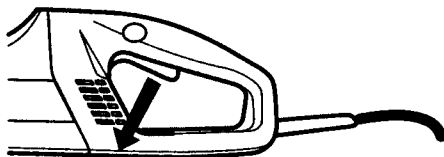

## Maintenance

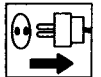

Partner's power cutters are robust and durable. However, as they are used at a high processing rate all service procedures must be carried out at the times and in the manner described, so that the machine always works efficiently and safely.

**WARNING! Inspection and/or maintenance should be carried out with the motor switched off and the plug disconnected.**

## Cooling system



The machine is equipped with an efficient fan to cool the motor.

Cooling air which is drawn in through the grille by the machines rear handle passes over the stator and rotor and out through the front of the motor housing.

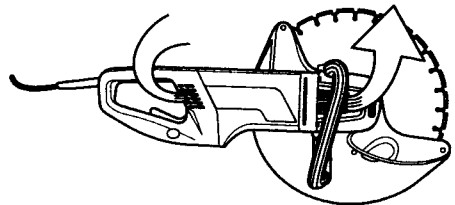

In order for the machine to always be cooled sufficiently the cooling air openings must be kept clear and clean. Blow down the machine regularly with compressed air.

## Replacing the carbon brushes

Check the carbon brushes at least once a month. The carbon brushes should be replaced with new brushes if they are worn, cracked or in any other way deformed. All carbon brushes must be replaced when the brushes are replaced.

Remove both inspection covers by loosening both screws.

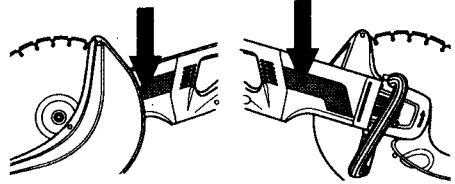

Unscrew the cable holding the carbon brush. Now lift up the spring and then lift out the carbon brush from the brush retainer.

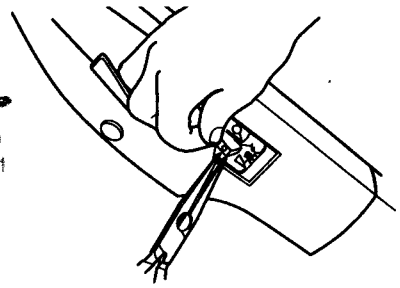

• Clean the brush retainers with a dry brush.

• Carefully blow away the dust.

• Fit the new carbon brushes and, at the same time, check that they slide easily in the brush retainers.

• Fold down the springs and tighten the cable.

• New carbon brushes must be run in for approximately 40 minutes while idling.

## Bevel gear

The grease in the gear housing should be changed every 4 months. Use high quality gear grease

The gear housing must not be filled completely with grease. The grease expands as the machine heats up during operation. If the gear housing was completely filled with grease it could damage the seals and lead to leakage of grease.

The gear housing should contain 90 g of grease in total.

## Changing the grease

The following parts must be dismantled to change the grease in the gear housing:

1 Flange washers holding the cutting blade

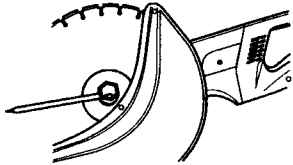

2 Support flange for the guard

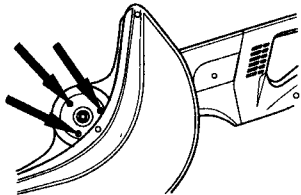

3 Guard

4 The four screws holding the shield. Lift the shield together with the drive wheel unit out of the gear housing.

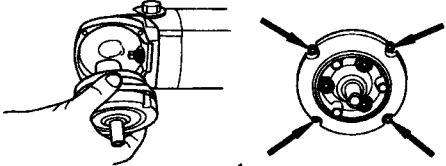

5 Wipe out the grease and fill with new, good quality gear grease. The gear housing should contain 90 g of grease in total.

**CAUTION!** Exercise care when dismantling so as not to damage the gaskets. These are used both as seals and spacers for the gear setting.

# MAINTENANCE

## Checking the drive shaft and flanges

Check that the threads on the drive shaft are undamaged.

Check that the contact surfaces of the cutting blade and flanges are flat, run correctly on the spindle and are free from foreign objects.

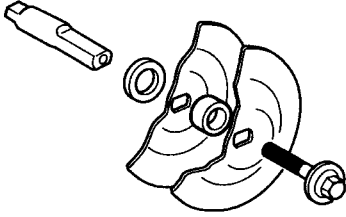

Do not use flanges that are twisted, have damaged edges, untrue or dirty. Do not use different size flanges..

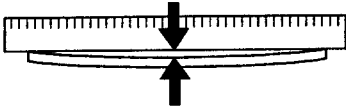

Below you will find some general maintenance instructions.

## Daily maintenance

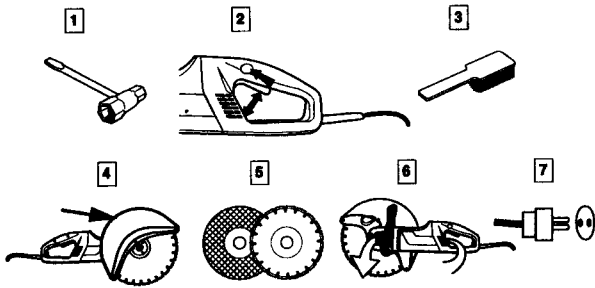

- 1 Check that nuts and screws are tight.
- 2 Check that the power switch unit works smoothly.
- 3 Clean the outside of the machine.
- 4 Inspection of the guard for the cutting blade
- 5 Check the condition of the cutting blade.
- 6 Check and clean the cooling air openings
- 7 Check that the cord and extension cord are intact and in good condition.

