

# Pump - For use anywhere

# 12V Pump 21 Amp

Portable-Submersible  
Model P3010

1-3

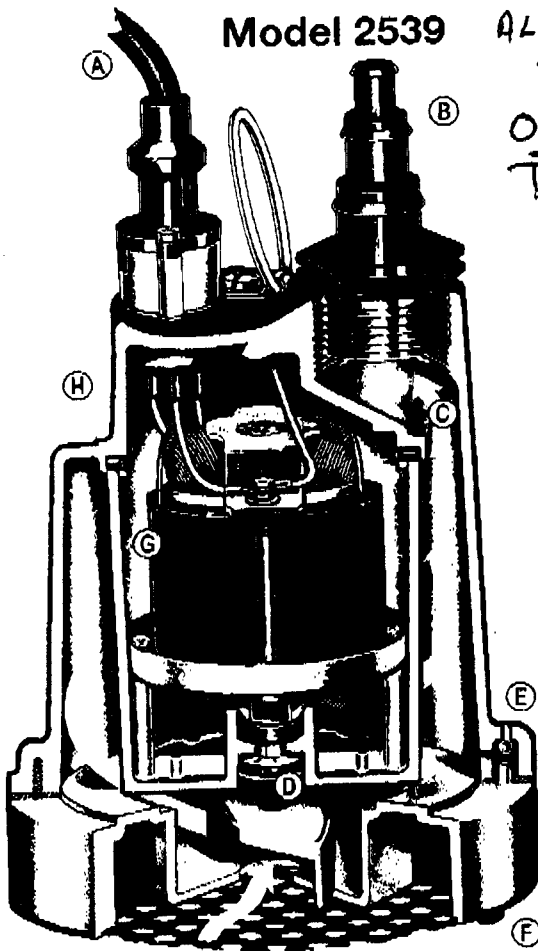

Model 2539

ALSO 2533  
" D6601

ONLY INLET CABLE  
DIFFERENCE  
10 METRE CABLE

## Simer Geyser

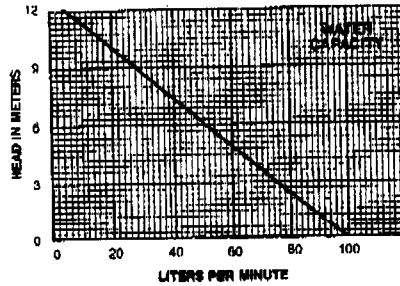

### MODEL P3010-12 Volt, 21 Amp

- 12 Volt DC battery powered
- Rugged thermoplastic construction
- 1-1/4" discharge with garden hose adapter
- Quiet operation
- 2.5 metre (8') cable
- Compact design fits into 177mm (7") opening
- Anti-airlock valve
- Portable - weighs approximately 4 kilos
- Corrosion resistant
- Field replaceable power cord

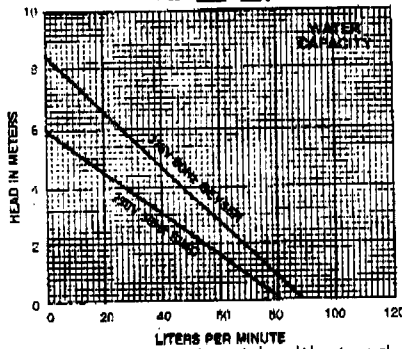

A portable pump should withstand rough handling. The all-metal Simer/Geyser is noted for its ability to stand "hard knocks".

Fast and powerful, light and compact, only 24 cm high and 17 cm in diameter, 4.5 kilos; sealed (no service required) — the Simer/Geyser will give years of quiet dependable service.

### THE INSIDE STORY

- (A) NEW Replaceable 2.5 or 10 metre power cable
- (B) NEW 1 1/4" BSP discharge with 3-step hose adapter
- (C) Water cooled motor housing
- (D) Lifetime ceramic face seal (Permits dry running)
- (E) Anti-Air Lock valve
- (F) Screened bottom inlet, pump to within 3 mm of floor
- (G) Simer built, oil filled motor with overload protection
- (H) All tough cast metal construction, epoxy coated inside and out

Model 2539 10 m cord **D6601**

USE IT ANYWHERE. Operates on battery power — no electrical outlet needed. Gives you pumping power for basements, boats, construction sites, on the farm, in camp or lake cottage. Provides low voltage operation for continuous use in fountains or waterfalls. Can be used as an emergency sump pump where regular power is unavailable.

PUMPS DOWN TO 3 mm. Geyser does a complete pumping job — bottom inlet screen keeps Geyser working where other pumps can't — pumps to within 1/8" (3 mm) of surface.

### PERFORMANCE POWER!

Geyser P3010 is high performance pump, providing ample pumping pressure. Pumps up to 98 litres (26 gal.) per minute.

ABN 45 003 63079

METROPOLITAN INDUSTRIAL SUPPLIES PTY. LTD.

ACN 003 630 797



Unit 1, 133 Coreen Avenue, Penrith NSW 2750 Australia  
Phone: 47 31 2005 — Fax: 47 31 3605

02-

02-

THIS MANUAL SUPPLIED WITH EVERS  
PUMP SUPPLIES



## OWNER'S MANUAL

MODELS: 6901 through 6906  
7101 through 7106

\* D6601 \*

505-094  
1-96

### Submersible Utility Pump

23

#### INTRODUCTION:

All Simer pumps are carefully designed and tested to provide quiet operation and long life. Your new Simer Submersible Utility Pump has been inspected and packaged to insure it arrives in perfect condition. Examine your pump closely to make sure there are no broken or damaged parts that may have occurred in transit. If any damage is noticed, return pump to place of purchase for replacement. Please be sure to read these instructions carefully, paying special attention to any **WARNING** or **CAUTIONS** to assure proper installation and operation.

#### VERY IMPORTANT SAFETY INFORMATION:

Always follow these rules to avoid bodily injury or property damage.

- (WARNING)** Risk Of electrical shock— This pump is supplied with a three conductor connection, including ground wire. To reduce the risk of electric shock, be certain that it is connected only to a **PROPERLY** grounded, grounding type receptacle.

#### 1) ELECTRICAL CONNECTION (MODELS 6902 & 7102 are supplied without wall plugs.)

(a) As the colours of the wires in the main leads of this appliance may not correspond with the coloured marking identifying the terminals in your plug, proceed as follows: The wire which is coloured green and yellow must be connected to the terminal in your plug which is marked with letter "E", by the Earth symbol, or coloured green or green and yellow. The wire which is coloured blue must be connected to the terminal which is marked by the letter "N" or coloured black. The wire which is coloured brown must be connected to the terminal which is marked with the letter "L" or coloured red.

#### (b) ELECTRICAL SAFETY WARNING:

In accordance with the latest I.E.E. regulations, but particularly for your added safety, the use of a Residual Current Device (RCD), otherwise

known as an Earth Leakage Protection Device is required. The Earth Leakage circuit-breaker must have a rated tripping current of not more than 30ma. These are not generally available from all good Electrical and "DIY" Superstore.

IF IN DOUBT, PLEASE CONSULT A QUALIFIED ELECTRICIAN.

- (WARNING)** RISK OF Electric shock This pump has not been investigated for use in swimming pool areas. Do not use when persons are in the pool.
  - (WARNING)** Electric shock hazard— may cause severe personal injury, death or substantial property damage. For your safety, turn off the electrical power supply at the service entrance before installing or servicing the pump to avoid any possible electrical shock hazards. Never make adjustments to a pump when the power is connected. When changing fuses, never stand in water or put your fingers in the fuse box socket. Either practice can result in a dangerous or even fatal electric shock.
  - (WARNING)** Electrical shock hazard—may cause severe personal injury, death or substantial property damage.
- RECOMMENDED GROUNDING METHOD:

**Crommelins**

**Machinery**

Perth Sydney Melbourne Brisbane Adelaide  
Established since 1958

**PORTABLE CONCRETE VIBRATOR  
MODEL – PV45R**

**OPERATION MANUAL**

**! WARNING**

To reduce the risk of injury, all operators and maintenance personnel must read and understand these instructions before operating, changing accessories, or performing maintenance on this equipment. All possible situations cannot be covered in these instructions. Care must be exercised by everyone using, maintaining or working near this equipment.

Hearing damage from excessive noise. Medium/Low

- Hearing protection with a rating of 20db must be worn.

Customer Identified Hazard(s)

---

---

**Key Operating Instructions**

Use unleaded fuel only (4 stroke).  
To start, ensure stop switch is in the ON position, throttle in low speed position.  
Prime the fuel bowl until it is full.  
For cold start close the choke lever.  
Pull the recoil rope to start, as the engine warms up return the choke lever to the open position.  
Always start the machine on the ground and pick up when running.  
To commence operation pull the throttle trigger until the desired speed is reached.  
Hold on to both handles and use the harness provided when operating.  
To stop the machine return the throttle to low speed and turn OFF the stop switch.  
Please refer to the User Guide and Operator's Manual for Operating Instructions

The Safety Information on this assessment has been developed for the Hire and Rental Industry to assist in the safe operation of this equipment.

This information contains general information only and should not be relied upon as a substitute for professional advice, which the user should seek before operating.

**WARRANTY**

ENGINE 24 MONTHS  
MACHINE 6 MONTHS

The warranty period begins from the date of purchase and covers defects in material and workmanship provided that:

- The product has been operated and maintained in accordance with the operating instructions.
  - Has not been damaged by accident, misuse or abuse.
  - Has not been tampered with or repaired by any unauthorized personnel.
- \* The owner is responsible for the cost of transportation to and from the authorized repairer and the unit is at the owners risk while in transit to and from the repairer.



**Hire and Rental Industry Association Ltd**  
Product Safety Assessment Sheet

**PLANT INFORMATION**

PSA Ref #: 00049  
Model No: PV45FR  
Plant Name: CROMMELINS PORTABLE VIBRATOR  
Manufacturer: Crommelins Machinery  
Manufacturer's Website: www.crommelins.com.au  
Web Link for Plant: www.crommelins.com  
Mandatory Personal Protective Equipment:  
 Foot Protection Hearing Protection Protective Clothing



**RISK ASSESSMENT INFORMATION**

Operator Competency: Plant Licence Not Required

Potential Hazard(s)	Risk Level	Control Measure(s)
Coming into contact with hot parts of the engine.	Low	<ul style="list-style-type: none"><li>The muffler is fitted with a heat shield. Let the engine cool down before attempting any maintenance. Avoid contact with hot parts of the engine.</li></ul>
Explosion or fire from fuel vapours.	Medium/Low	<ul style="list-style-type: none"><li>Stop the engine before refuelling. Do not refuel while hot. Avoid spillage of fuel when refuelling. Ensure the fuel cap is properly secured after refuelling. Carry out visual checks for fuel leaks and repair before operation. Keep flammables away from the engine.</li></ul>
Inhaling exhaust or fuel fumes.	Medium/Low	<ul style="list-style-type: none"><li>Only operate in a well ventilated area. Do not operate in a confined space. Avoid breathing petrol fumes. Avoid skin contact with petrol.</li></ul>
Coming into contact with moving parts.	Low	<ul style="list-style-type: none"><li>Keep hands and feet away from the vibrating end. Exposure to vibration can be harmful. Hold the unit with both hands on the handles provided and use the shoulder strap to support the unit.</li></ul>
Slip/Trip/Fall:	Low	<ul style="list-style-type: none"><li>Start the unit on a flat level surface and only pick up when it is running to avoid loss of balance. Beware of uneven or slippery work surfaces and exercise care when working around holes or obstacles.</li></ul>

# PORTABLE VIBRATOR

## PORTABLE VIBRATOR ASSEMBLY

No.	Part No.	Description	Qty.	Remark
1	7365-001	End cap	1	
2	4028-15036	O-ring 1.5x36	1	
3	4900-00015	Grip 3A75	1	
4	4000-03202	Bearing 3202	2	
5	7365-003	Rotor shaft	2	
6	7365-002	Barrel	1	
7	7365-004	Rotor connector	1	
8	4701-16287	Oil seal TC 16x28x7	2	
9	7365-005	Oil seal housing	1	
10	4908-15019	O-ring 1.5x19	1	
11	7365-008	Front end casing	1	
12	4921-00130	Spring flter	1	
13	4921-00131	Spring liner clamp	1	
14	4914-40808	Flexible shaft	1	
15	4015-12808	Outer casing	1	
16	7365-009	Back end casing	1	
17	4908-15025	O-ring 1.5x25	1	
18	7365-010	Flexible connector	1	
19	4002-00808	Bearing 808	2	
20	7365-011	Spacer	1	
21	7365-012	Shaft connector	1	
22	7365-013	Split connector	1	
23	4013-10006	Spilly washer M6	2	
24	4411-08025	Cap screw M6x25L	2	
25	4451-08010	Set screw M6x10L	1	
26	7365-050	Moulding block	1	
27	4931-00530	Lubricant SAE #20 (Pennzoil)	20ml	
28	4931-50707	Grease (Pennzoil)	20ml	

### ! CHEMICAL HAZARDS

Do not operate in a confined area without adequate ventilation. Carbon Monoxide exhaust gases from internal combustion engines can cause death in confined spaces.

### ! NOISE HAZARDS

Excessive noise can lead to temporary or permanent loss of hearing. Wear an approved hearing protection device to limit noise exposure, as required by Occupational Health and Safety Regulations.

### PROTECTIVE CLOTHING

Always wear protective clothing and footwear to prevent contact with wet concrete. Goggles and gloves may also be necessary.

### ! ADDITIONAL HAZARDS

Slip/Trip/Fall is a major cause of serious injury or death. Avoid loss of balance by starting the unit on a flat, level surface and only pick up when it is operating. Beware of uneven or slippery work surfaces. Exercise care when working in the vicinity of unprotected holes or excavations.

### OPERATION

To start the machine, place on a flat level surface and turn the engine switch to ON. Move the choke lever to the closed position. Press the priming pump until fuel is seen in the fuel tube. Pull the starter slowly until resistance is felt, pull briskly to start but do not pull out the recoil rope to the end. Return the starter grip to the normal position. Open the choke lever as the engine warms up. Operate the unit at high speed to ensure the clutch is engaged and the correct compaction is achieved. Avoid sharp bends when in use or damage to the flex shaft could result. Do not use as an external vibrator or leave running for extended periods out of the concrete as the unit needs to be immersed in the wet concrete to remain cool.

### CARE & PREVENTATIVE MAINTENANCE

Check the oil level in the motor crankcase daily. Check the air cleaner element daily. Keep the unit clean and free of concrete build up. Regular maintenance and inspection for damage to the vibrator and shaft is required to avoid premature wear. Rectify any faults immediately.

### SERVICE

Change the oil in the motor crankcase regularly to minimize wear. Inspect, clean and/or replace the motor air cleaner regularly, particularly when operating in a dusty environment. Inspect, clean and/or replace the spark plug regularly. Check all fasteners for tightness as the machine is subject to vibration.

# Robin

**Brush Cutter**  
**Decespugliatore**  
**Desbrozadora**  
**Cortador de Grama**

**BH3500**  
**BH3600**

## INSTRUCTION MANUAL

**Important:**

Read this instruction manual carefully before putting the Brush Cutter into operation and strictly observe the safety regulations!  
Preserve instruction manual carefully!

## ISTRUZIONI D'USO

**Importante:**

Prima di mettere in funzione il decespugliatore, leggere attentamente il presente manuale; rispettare rigorosamente le norme di sicurezza!  
Conservare il manuale delle istruzioni per l'uso!

## MANUAL DE INSTRUCCIONES

**Importante:**

Leer cuidadosamente este manual de instrucciones antes de poner en marcha la máquina y observar estrictamente las normas de seguridad.  
Conservar este manual de instrucciones con cuidado.

## MANUAL DE INSTRUÇÕES

**Importante**

Leia este manual cuidadosamente antes de pôr o Cortador/Aparador de Grama em funcionamento e observe rigorosamente as normas de segurança.  
Conserve este manual de instruções com cuidado.

Thank you very much for purchasing the ROBIN Brush Cutter. We are pleased to recommend to you the ROBIN Brush Cutter which is the result of a long development programme and many years of knowledge and experience.















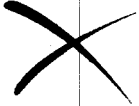





Please read this booklet which refers in detail to the various points that will demonstrate its outstanding performance. This will assist you to obtain the best possible result from your ROBIN Brush Cutter.



Table of Contents	Page
Symbols .....	1
Safety instructions .....	2
Technical data .....	7
Designation of parts .....	8
Mounting of handle for BH3600 .....	9
Assembly of engine and shaft for BH3500 .....	10
Mounting of handle for BH3500 .....	10
Mounting of control cable .....	12
Mounting of protector .....	13
Mounting of cutter blade or nylon cutting head .....	14
Before start of operation .....	15
Correct handling of machine .....	17
Points in operation and how to stop .....	17
Resharpener the cutting tool .....	19
Servicing instructions .....	20
Storage .....	23

## SYMBOLS

You will note the following symbols when reading the instructions manual.

	Read instruction Manual		Wear protective helmet, eye and ear protection (for Brush Cutter only)
	Take Particular care and Attention		Do not use metal blades (for grass trimmer only)
	Forbidden		Top permissible tool speed
	Keep distance		Fuel (Gasoline)
	Flying object hazard		Engine-Manual start
	No smoking		Emergency stop
	No open flame		First Aid
	Protective gloves must be worn		Recycling
	Kickback		ON/START
	Keep the area of operation clear of all persons and pets		OFF/STOP
	Wear eye and ear protection (for Grass trimmer only)		

# SAFETY INSTRUCTIONS

## General Instructions

To ensure correct operation, user has to read this instruction manual to make himself familiar with the handling of the brush cutter. Users insufficiently informed will risk danger to themselves as well as others due to improper handling.

It is recommended only to lend the brush cutter to lend the brush cutter to people who have proven to be experienced with brush cutters. Always hand over the instruction manual.

First user should ask the dealer for basic instructions to familiarize oneself with the handling of an engine powered cutter.

Children and young persons aged under 18 years must not be allowed to operate the brush cutter. Persons over the age of 16 years may however use the device for the purpose of being trained only whilst under supervision of a qualified trainer.

Use brush cutters with the utmost care and attention.

Operate the brush cutter only if you are in good physical condition. Perform all work calmly and carefully. The user has to accept liability for others.

Never use the brush cutter after consumption of alcohol or drugs, or if feeling tired or ill.

## Intended use of the machine

The Brush cutter is only intended for cutter grass, weeds, Bushes, undergrowth it should not be used for any other purpose such as Edging or hedge cutting as this may cause injury.

## Personal protective equipment

The clothing worn should be functional and appropriate, i.e. it should be tight-fitting but not cause hindrance. Do not wear either jewelry or clothing which could become entangled with bushes or shrubs.

In order to avoid either head-, eye-, hand- or foot injuries as well as to protect your hearing the following protective equipment and protective clothing must be used during operation of the brush cutter.

Always wear a helmet where there is a risk of falling objects. The protective helmet (1) is to be checked at regular intervals for damage and is to be replaced at the latest after 5 years. Use only approved protective helmets.

The visor (2) of the helmet (or alternatively goggles) protects the face from flying debris and stones. During operation of the brush cutter always wear goggles, or a visor to prevent eye injuries.

Wear adequate noise protection equipment to avoid hearing impairment (ear muffs (3), ear plugs etc.).

The work overalls (4) protect against flying stones and debris. We strongly recommend that the user wears work overalls.

Special gloves (5) made of thick leather are part of the prescribed equipment and must always be worn during operation of the brush cutter.

When using the brush cutter, always wear sturdy shoes (6) with a non-slip sole. This protects against injuries and ensures a good footing.

## Starting up the brush cutter

Please make sure that there are no children or other people within a working range of 15 meters (49ft), also pay attention to any animals in the working vicinity.

Before use always check that the brush cutter is safe for operation: Check the security of the cutting tool, the control lever for easy action and check for proper functioning of the control lever lock.

Rotation of the cutting tool during idling speed is not allowed. Check with your dealer for adjustment if in doubt. Check for clean and dry handles and test the function of the start/stop switch.

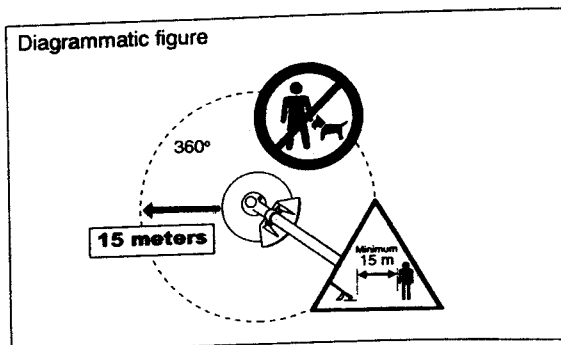
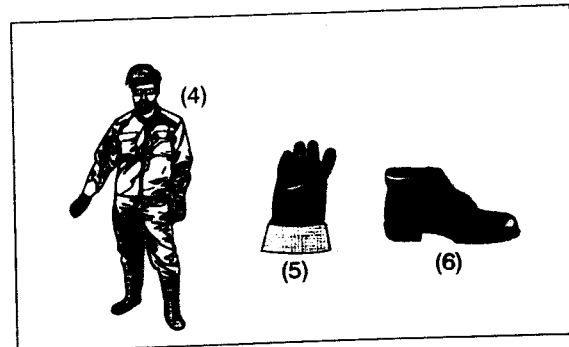
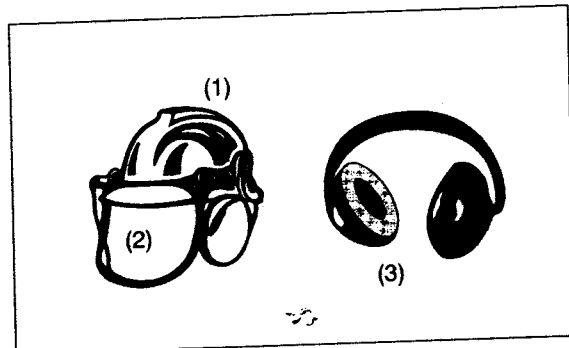
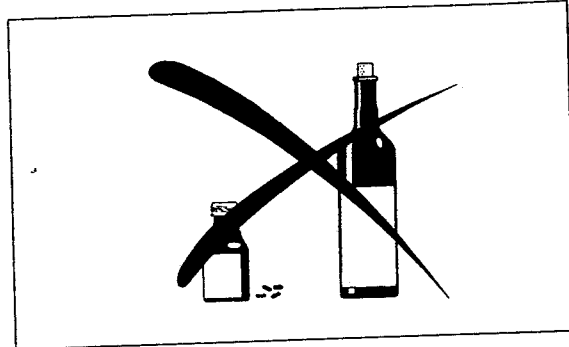
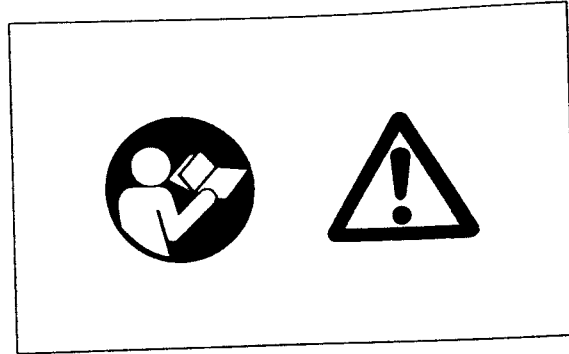

Start the brush cutter only in accordance with the instructions.

Do not use any other methods for starting the engine!

- Use the brush cutter and the tools only for such applications as specified.
- Only start the brush cutter engine, after the entire assembly is done. Operation of the device is only permitted after all the appropriate accessories are attached!
- Before starting make sure that the cutting tool has no contact with hard objects such as branches, stones etc. as the cutting tool will revolve when starting.
- The engine is to be switched off immediately in case of any engine problems.
- Should the cutting tool hit stones or other hard objects, immediately switch off the engine and inspect the cutting tool.
- Inspect the cutting tool at short regular intervals for damage (detection of hairline cracks by means of tapping-noise test).
- Operate the brush cutter only with the shoulder strap attached which is to be suitably adjusted before putting the brush cutter into operation. It is essential to adjust the shoulder strap according to the user's size to prevent fatigue occurring during use. Never hold the cutter with one hand during use.
- During operation always hold the brush cutter with both hands. Always ensure a safe footing.
- Operate the brush cutter in such a manner as to avoid inhalation of the exhaust gases. Never run the engine in enclosed rooms (risk of gas poisoning). Carbon monoxide is an odorless gas.
- Switch off the engine when resting and when leaving the brush cutter unattended, and place it in a safe location to prevent danger to others or damage to the machine.
- Never put the hot brush cutter onto dry grass or onto any combustible materials.
- The cutting tool has to be equipped with it's appropriate guard. Never run the cutter without this guard!
- All protective installations and guards supplied with the machine must be used during operation.
- Never operate the engine with faulty exhaust muffler.
- Shut off the engine during transport.
- During transport over long distances the tool protection included with the equipment must always be used.
- Ensure safe position of the brush cutter during car transportation to avoid fuel leakage.
- When dispatching the brush cutter, ensure that the fuel tank is completely empty.
- When unloading the Brush Cutter from the truck, never drop the Engine to the ground or this may severely damage the fuel tank.
- Except in case of emergency, never drop or cast the Brush Cutter to the ground or this may severely damage the Brush Cutter
- Remember to lift the entire equipment from the ground when moving the equipment. Dragging the fuel tank is highly dangerous and will cause damage and leakage of fuel, possibly causing fire.

### Refuelling

- Shut off the engine during refuelling, keep away from naked flames and do not smoke.
- Avoid skin contact with mineral oil products. Do not inhale fuel vapor. Always wear protective gloves during refuelling. Change and clean protective clothing at regular intervals.
- Take care not to spill either fuel or oil in order to prevent soil contamination (environmental protection). Clean the brush cutter immediately after fuel has been spilt.
- Avoid any fuel contact with your clothing. Change your clothing instantly if fuel has been spilt on it (to prevent clothing catching fire).
- Inspect the fuel cap at regular intervals making sure that it can be securely fastened and does not leak.
- Carefully tighten the fuel tank cap. Change location to start the engine (at least 3 meters away from the place of refuelling).
- Never refuel in closed rooms. Fuel vapors accumulate at ground level (risk of explosions).
- Only transport and store fuel in licensed containers. Make sure the fuel stored is not accessible to children.

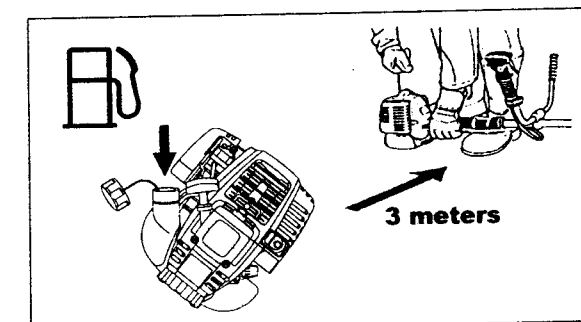
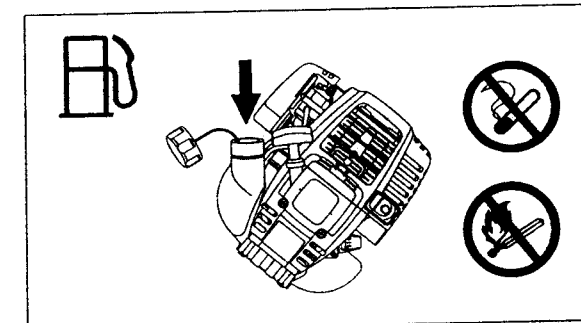
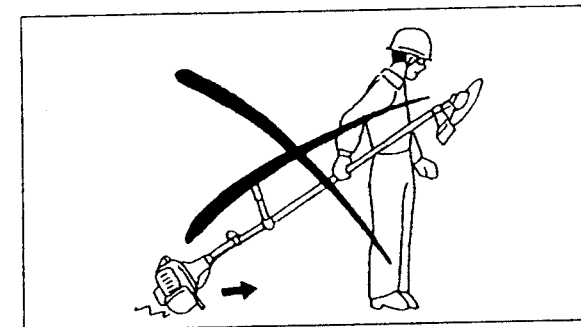
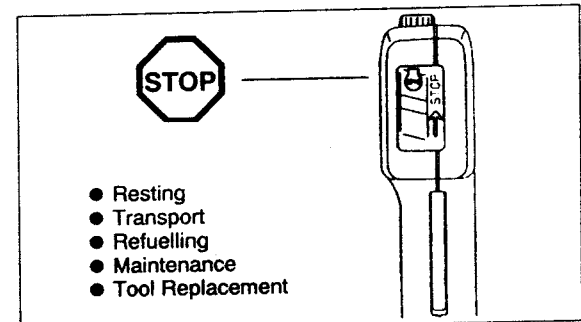
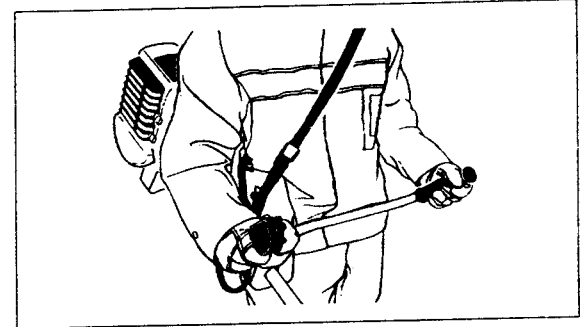
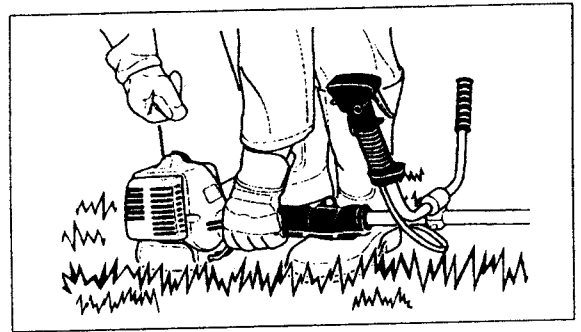

### Method of operation

- Only use the brush cutter in good light and visibility. During the winter season beware of slippery or wet areas, ice and snow (risk of slipping). Always ensure a safe footing.
- Never cut above waist height.
- Never stand on a ladder and run the brush cutter.
- Never climb up into trees to perform cutting operation with the brush cutter.
- Never work on unstable surfaces.
- Remove sand, stones, nails etc. found within the working range. Foreign particles may damage the cutting tool and can cause dangerous kickbacks.
- Before commencing cutting, the cutting tool must have reached full working speed.

### Kickback

- When operating the brush cutter, uncontrolled kickback may occur.
- This is particularly the case when attempting to cut within a blade segment between 12 and 2 o'clock.
- Never apply the brush cutter within a segment between 12 and 2 o'clock.
- Never apply this segment of the brush cutter blade to solids, such as bushes and trees, etc., having a diameter in excess of 3 cm or the brush cutter will be deflected at great force with the risk of injuries.

### Kickback prevention

#### To avoid kickbacks, observe the following:

- Operation within a blade segment between 12 and 2 o'clock presents positive hazards, especially when using metal cutting tools.
- Cutting operations within a blade segment between 11 and 12 o'clock, and between 2 and 5 o'clock, must only be performed by trained and experienced operators, and then only at their own risk.
- Easy cutting with almost no kickback is possible within a blade segment between 8 and 11 o'clock.

### Cutting Tools

Employ only the correct cutting tool for the job in hand.

BH3500, BH3600 with cutter blade (Star Blade (4 teeth), Eddy Blade (8 teeth)),  
Brush Blade(3 teeth), Nylon cutting head

For cutting thick materials, such as weed, high grass, bushes, shrubs, underwood, thicket etc. (max. 2 cm dia. thickness). Perform this cutting work by swinging the brush cutter evenly in half-circles from right to left (similar to using a scythe).

### Maintenance instructions

- The condition of the cutter, in particular of the cutting tool of the protective devices and also of the shoulder strap must be checked before commencing work. Particular attention is to be paid to the cutting blades which must be correctly sharpened.
- Turn off the engine and remove spark plug connector when replacing or sharpening cutting tools, and also when cleaning the cutter or cutting tool.

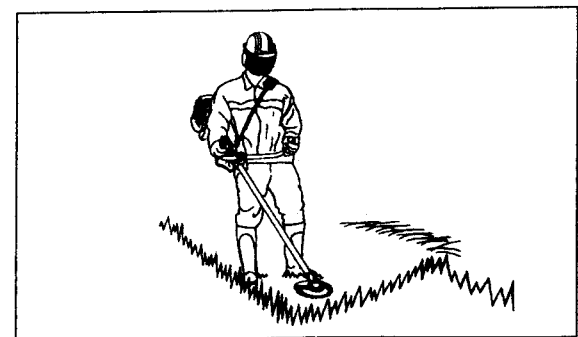
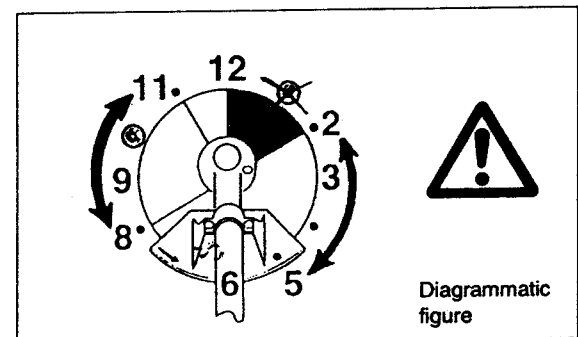
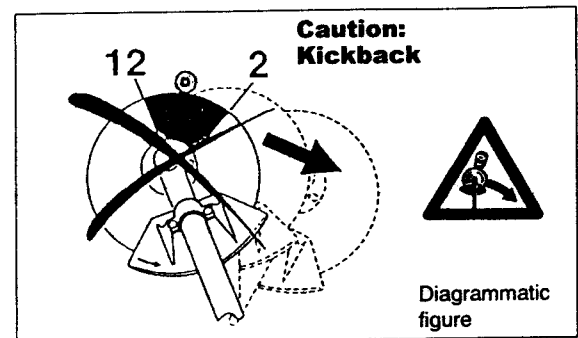

### Never straighten or weld damaged cutting tools.

- Operate the brush cutter with as little noise and contamination as possible. In particular check the correct setting of the carburetor.
- Clean the brush cutter at regular intervals and check that all screws and nuts are well tightened.
- Never service or store the brush cutter in the vicinity of naked flames.
- Always store the brush cutter in locked rooms and with an emptied fuel tank.

Observe the relevant accident prevention instructions issued by the relevant trade associations and by the insurance companies.

Do not perform any modifications on the brush cutter as this will endanger your safety.

The performance of maintenance or repair work by the user is limited to those activities as described in the instruction manual. All other work is to be done by an Authorized Service Agent. Use only genuine spare parts and accessories released and supplied by ROBIN.

Use of non-approved accessories and tools means increased risk of accidents. ROBIN will not accept any liability for accidents or damage caused by the use of non-approved cutting tools and fixing devices of cutting tools, or accessories.



### First Aid

In case of accident make sure that a first-aid box is available in the vicinity of the cutting operations. Immediately replace any item taken from the first aid box.

**When asking for help, please give the following information:**

- Place of accident
- What happened
- Number of injured persons
- Kind of injuries
- Your name

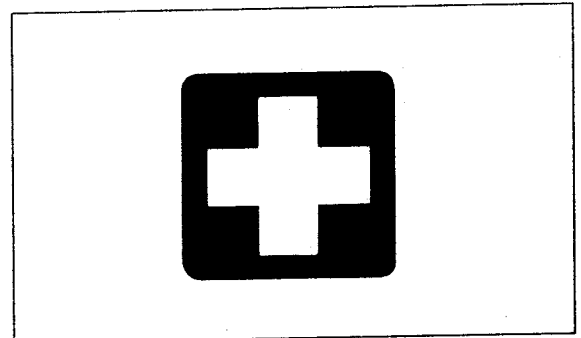

### Packaging

The ROBIN brush cutter will be delivered in two protective cardboard boxes to prevent transport damage. Cardboard is a basic raw material and is therefore consequently reusable or suitable for recycling (waste paper recycling).



## EC DECLARATION OF CONFORMITY

With "The Supply of Machinery (Safety) Regulations 1992, amended 1994  
Implementing the EC Machinery Directive 89/392/EEC amended 91/368/EEC, 93/68/EEC,  
89/336/EEC amended 92/31/EEC, Noise Emission Directive 2000/14/EC

Machine manufactured by:-

Name:- Fuji Robin Industries Ltd.

Address:- 35 OHOKA, NUMAZU - CITY, SHIZUOKA - PREF, 410-8535 JAPAN

Machine Imported by and responsible person for the UK:-

Name:- REDBREAST INDUSTRIAL EQUIPMENT LIMITED.

Address:- 1 Staveley Way, Brixworth, Northampton, NN6 9EU U.K.

Machine:- BH3500, BH3600

Description:- Brush cutter

Serial numbers:- 02500001

These machines comply with the essential health and safety requirements of the above  
directive

EN ISO 11806 June 1997

Guaranteed Sound Power : 115 dB

Measured Sound Power : 111 dB

Shizuoka,

1 Jul. 2004

FUJI ROBIN INDUSTRIES LTD.



Mitsunori Watanabe

General Manager

Engineering Department

# TECHNICAL DATA

Model		BH3600 AU	BH3500 AU	BH3500 A		
		U handle	U handle	J handle		
Dimensions : length x width x height (without cutting blade)	mm	1810 x 620 x 550	1810 x 620 x 450	1810 x 340 x 280		
Mass (without plastic guard and cutting blade)	kg	7.6	6.9	6.9		
Volume (fuel tank)	L	0.65				
Cutting attachments (cutter blade dia.)	mm	255 (Refer to the text P.13)				
Engine displacement	cm <sup>3</sup>	33.5				
Maximum engine performance	kw	1.07 at 7000 min <sup>-1</sup>				
Maximum rotational frequency of the spindle	min <sup>-1</sup>	6850				
Engine speed at recommended max. spindle rotational frequency	min <sup>-1</sup>	10000				
Fuel consumption at max. engine performance	kg/h	0.458				
Specific fuel consumption at max. engine performance	g/kwh	426				
Engine speed at idling	min <sup>-1</sup>	3000				
Clutch engagement speed	min <sup>-1</sup>	4100				
Carburetor (Diaphragm - carburetor)	type	WALBRO WYJ				
Ignition system	type	Solid state ignition				
Spark plug	type	NGK CMR6A				
Electrode gap	mm	0.7 - 0.8				
Vibration per ISO 7916 <sup>1)</sup>	Right handle (Rear grip)	Idling	m/s <sup>2</sup>	2.79	2.67	4.82
		Racing or W.O.T	m/s <sup>2</sup>	2.27	6.70	13.77
	Left handle (Frontgrip)	Idling	m/s <sup>2</sup>	3.06	3.06	5.22
		Racing or W.O.T	m/s <sup>2</sup>	2.19	5.96	12.38
Sound pressure level average to ISO 7917 <sup>1)</sup>	dB	91.2				
Sound power level average to ISO 10884 <sup>1)</sup>	dB	103.6				
Fuel		Automobile gasoline				
Engine oil		Specified Robin oil, or SAE 10W-30 oil API Classification, Class SF or higher (4-stroke engine for automobile).				
Gear ratio		13/19				

1) The data is prepared taking equally into account the idling and racing or wide-open throttle speed operating modes.

# DESIGNATION OF PARTS

**BH3600(AU)  
Brush Cutter**

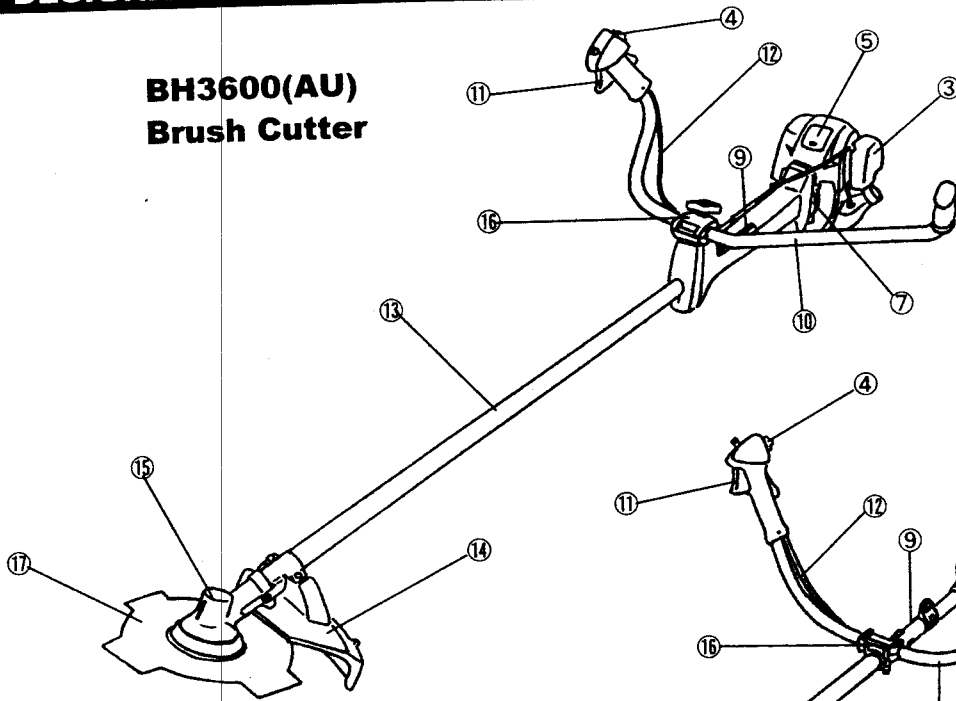

**BH3500(AU)  
Brush Cutter**

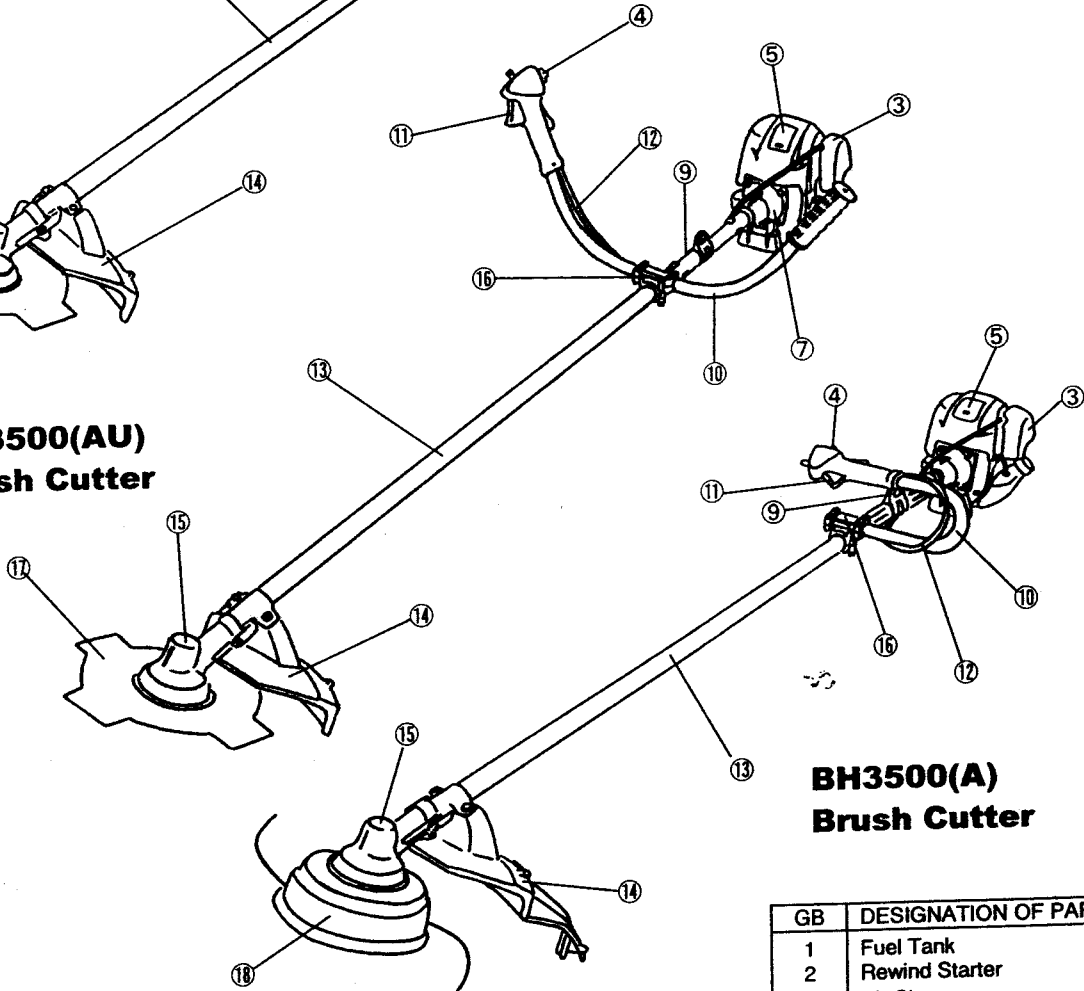

**BH3500(A)  
Brush Cutter**

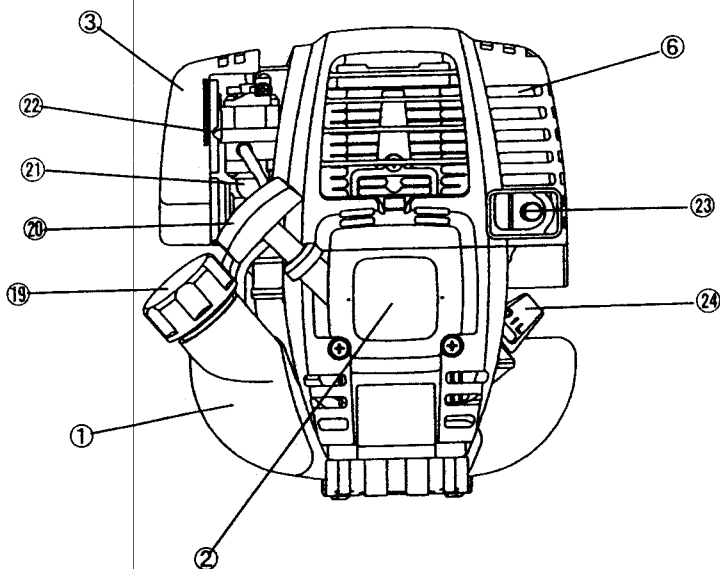

GB	DESIGNATION OF PARTS
1	Fuel Tank
2	Rewind Starter
3	Air Cleaner
4	I-O Switch (on/off)
5	Spark Plug
6	Exhaust Muffler
7	Clutch Case
9	Hanger
10	Handle
11	Control Lever
12	Control Cable
13	Shaft
14	Protector
15	Gear Case/Head Case
16	Handle Holder
17	Cutter Blade
18	Nylon Cutting Head
19	Fuel Filler Cap
20	Starter Knob
21	Primer Pump
22	Choke Lever
23	Exhaust Pipe
24	Oil Gauge

## MOUNTING OF HANDLE FOR BH3600

**CAUTION:** Before doing any work on the brush cutter, always stop the engine and pull the spark plug connector off the spark plug.  
Always wear protective gloves!

**CAUTION:** Start the brush cutter only after having assembled it completely.



- Place the handle with throttle lever on the handle holder in such a manner that it will be on the right side (to be held by the right hand) viewed from the engine side.
- Provisionally fix the upper side of the handle holder with the attached bolt (1).
- Adjust the handle to an angle easy to manipulate, and fix it by the bolt.

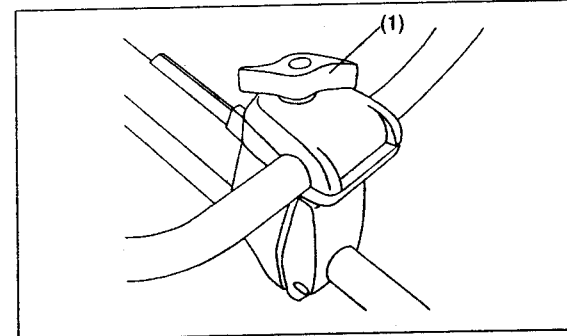
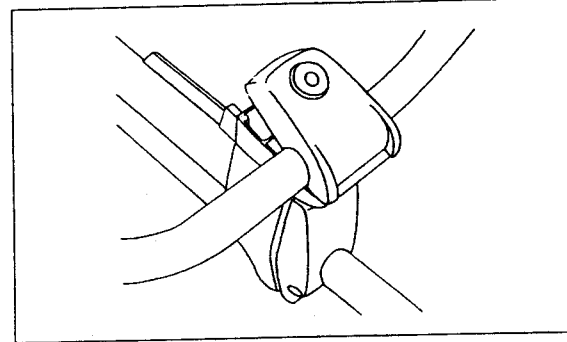

- Fix the control cable by three clips (2).

**Note:** If the control cable is not kept tight, it may be caught by a twig, leading to an accident.

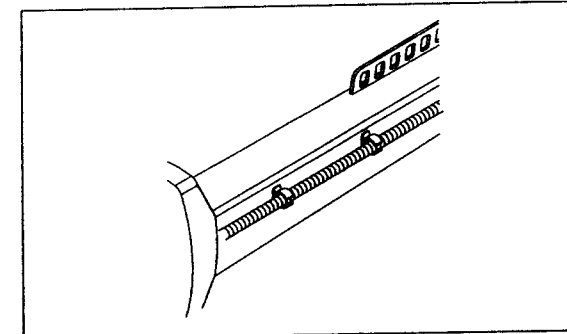
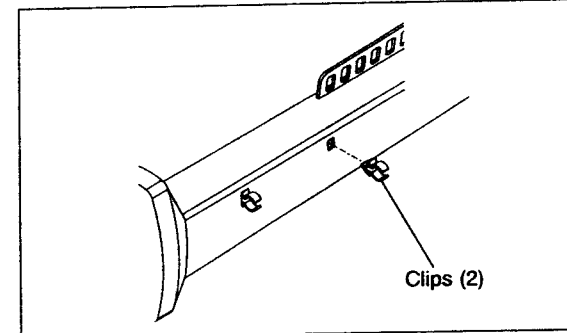

## ASSEMBLY OF ENGINE AND SHAFT FOR BH3500

**CAUTION:** Before doing any work on the brush cutter, always switch off the motor and pull the spark plug connector off the spark plug.  
Always wear protective gloves!

**CAUTION:** Start the brush cutter only after having assembled it completely.

- After checking the parts, fasten the drive shaft to the engine with four bolts M6 x 22(1).

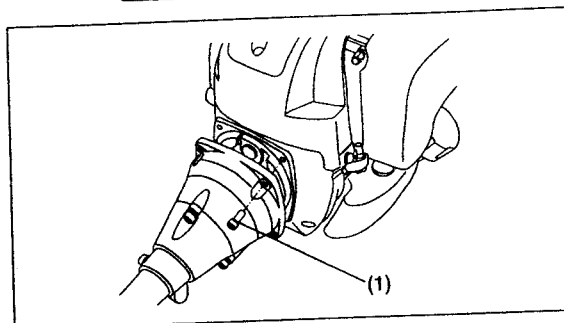

- Mount the stand by two screws M5 x 14.

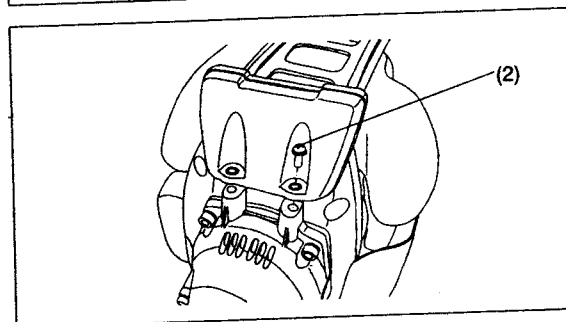

## MOUNTING OF HANDLE FOR BH3500



### For machines with U handle models

- Place the handle with the throttle lever on the handle holder on the right side (to be held by the right hand) and the other on the left side.
- Fit the handle edge to the handle holder groove, and provisionally fix the upper side (3) of the handle holder by four bolts M5 x 25 (4).
- Adjust the handle to an angle easy to manipulate, and tighten the bolt (4) uniformly on the right and left sides.

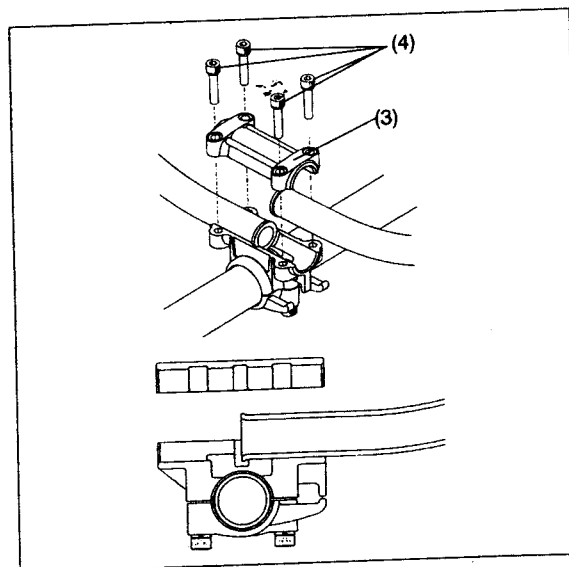

- Fix the control cable to the shaft by two clips (5).

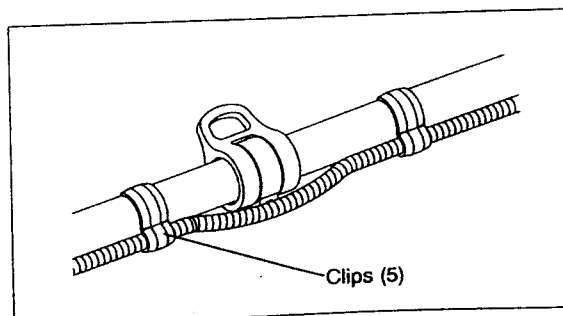

**For machines with J handle models**

- Fit the handle edge to the handle holder groove, and provisionally fix the upper side (3) of the handle holder by four bolts M5 x 25 (4).
- Adjust the handle to an angle easy to manipulate, and tighten the bolt (4) uniformly on the right and left sides.

Note: Handle mounting position.

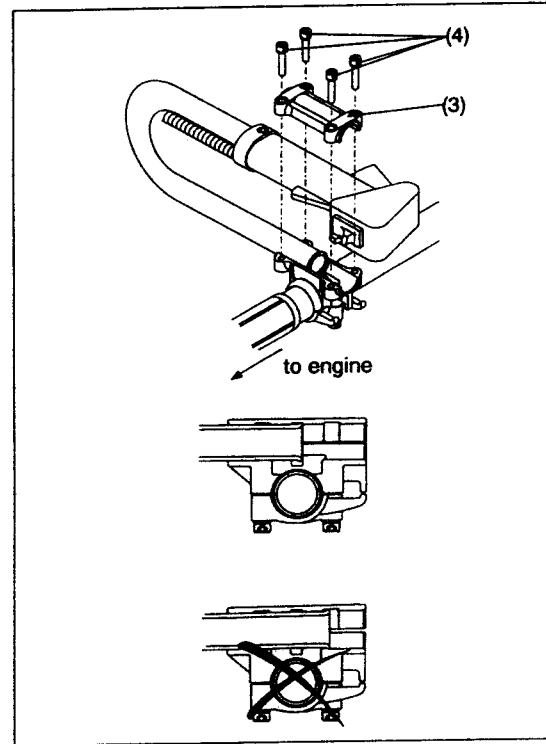

- Pass the control cable (6) through the rear grip (7) and insert tube (8) in the control cable (6).

- Fix the control cable to the handle and shaft by two clamps.

Note: If the control cable is not tight, it may be caught by twig, leading to an accident.

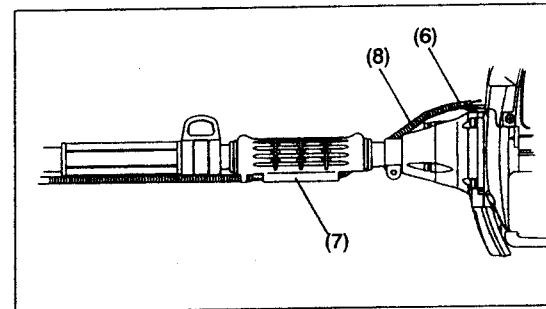

**Lay out the control cable as indicated in the figure.**

Note: If the control cable is not tight, it may be caught by a twig, leading to an accident.

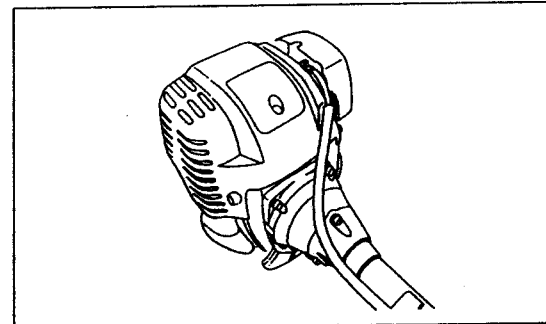

## MOUNTING OF CONTROL CABLE

- Remove the air cleaner cover.
- Place the control cable (1) in the adjusting bolt (2), and shift the swivel (3) so that the cable will be put in the swivel groove. At this time, the round-hole side of the swivel will be oriented toward the inner wire end-metal fitting.
- Release the swivel, and confirm that the inner wire-end metal fitting will be placed in the hole.
- Mount the air cleaner cover.

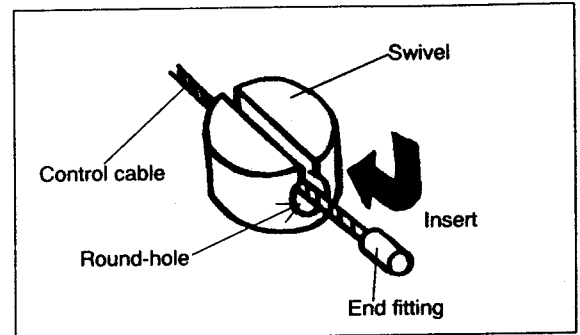
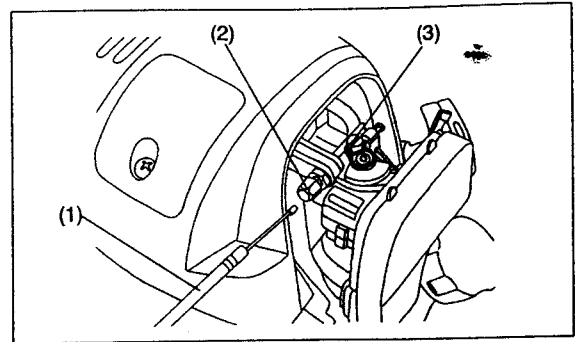

## CONNECTION OF SWITCH CORD

- Connect the switch cords to the two cords from the engine by inserting one into the other.
- Fix the cord connector by clamp (4).

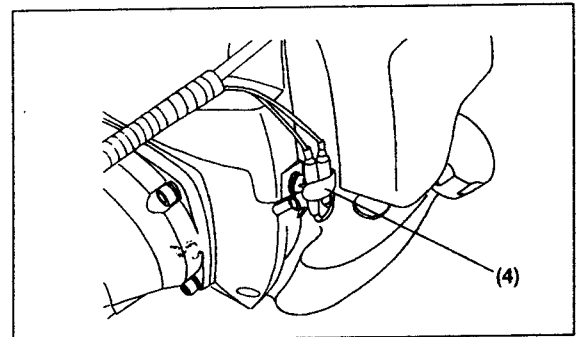

## ADJUSTMENT OF CONTROL CABLE

Adjust the control cable by adjusting bolt so that it will have 1 to 2 mm play when the throttle lever is set to the low-speed position by carburetor adjusting bolt. (Be careful that the cutter blade will not turn in idling.)

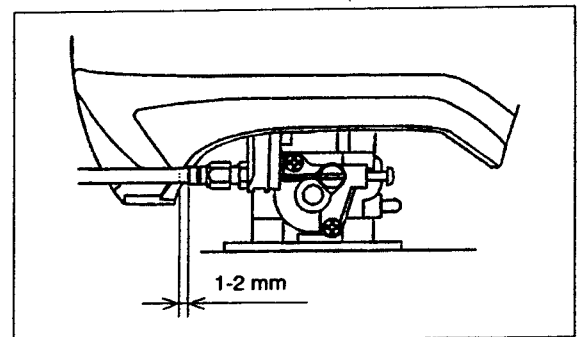

# MOUNTING OF PROTECTOR

To meet the applicable safety provisions, only the tool/protector combinations as indicated in the table must be used.



**Be sure to use genuine ROBIN cutter blades or nylon cutting head.**

- The cutter blade must be well polished, free of cracks or breakage. If the cutter blade hits against a stone during operation, stop the engine and check the blade immediately.
- Polish or replace the cutter blade every three hours of operation.
- The outside diameter of the cutter blade must be 255mm (10-1/32"). Never use any blades surpassing 255mm (10-1/32") in outside diameter.
- If the nylon cutting head hits against a stone during operation, stop the engine and check the nylon cutting head immediately.
- The mounting hole for the cutter blade is 25.4mm (1").

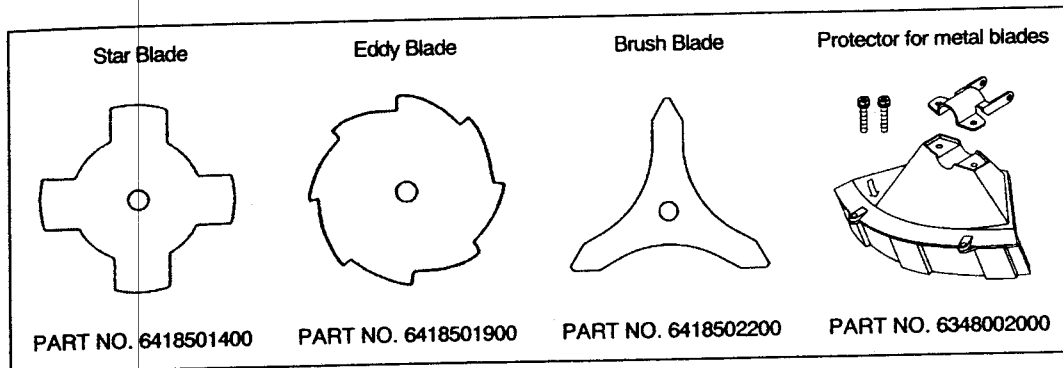

**CAUTION:** The appropriate protector must always be installed, for your own safety and in order to comply with accident-prevention regulations. Operation of the equipment without the guard being in place is not permitted.

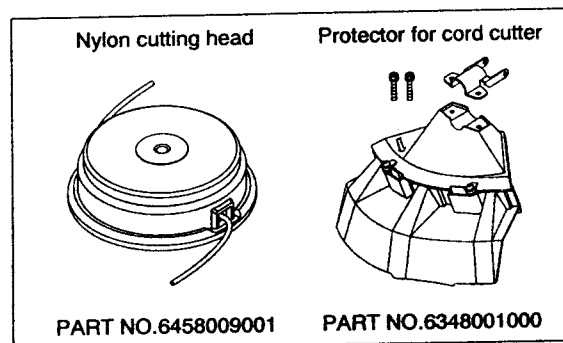

- Fix the protector (1) to the clamp (3) with two bolts M6 x 30 (2).

**NOTE:** Tighten the right and left bolts evenly so that the gap between the clamp (3) and the protector (1) will be constant. Otherwise, the protector sometimes may not function as specified.

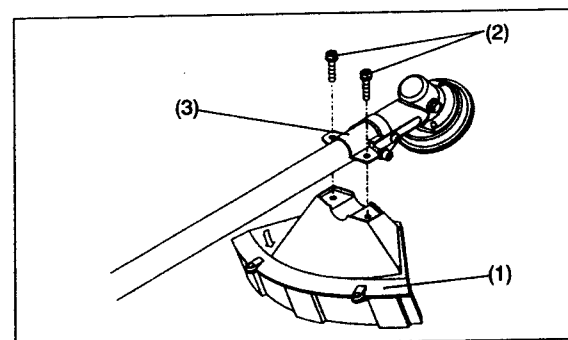

- In use of the nylon cutting head insert the protector (6) into the protector (1), and fasten them with two screw (4) and two nuts (5).

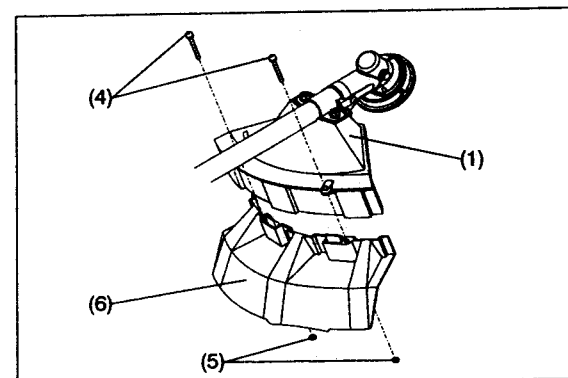

## MOUNTING OF CUTTER BLADE OR NYLON CUTTING HEAD

Turn the machine upside down, and you can replace the cutter blade or the nylon cutting head easily.



- Insert the hex wrench through the hole in the gear case and rotate the receiver washer (4) until it is locked with the hex wrench.
- Loosen the nut (1) (left-hand thread) with the socket wrench and remove the nut (1), cup (2), and clamp washer (3).

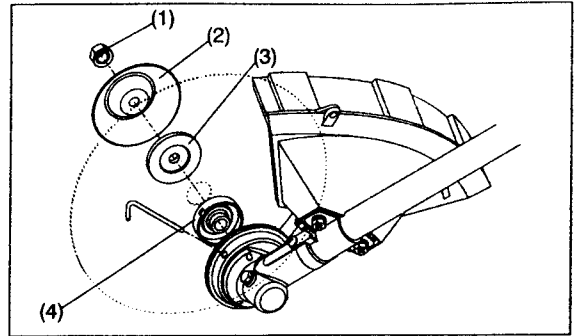

### Mounting of cutter blade

With the hex wrench still in place.

- Mount the cutter blade onto the shaft so that the guide of the receiver washer (4) fits in the arbor hole in the cutter blade. Install the clamp washer (3), cup (2), and secure the cutter blade with the nut (1).  
[Tightening torque: 13 - 23 N · m]

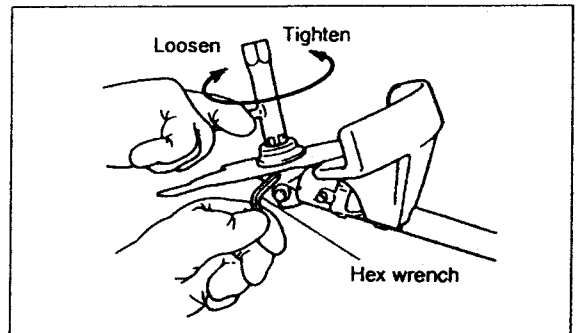

NOTE: Always wear gloves when handling the cutter blade.

NOTE: The cutter blade-fastening nut (with coned disc spring) is a consumable part.  
If there appears any wear or deformation on the coned disc spring, replace the nut.

### Mounting of nylon cutting head

- The clamp washer (3), cup (2), and nut (1) are not necessary for mounting the nylon cutting head. The nylon head should go on top of the receiver washer (4).
- Insert the hex wrench through the hole in the gear case and rotate the receiver washer (4) until it is locked with the hex wrench.

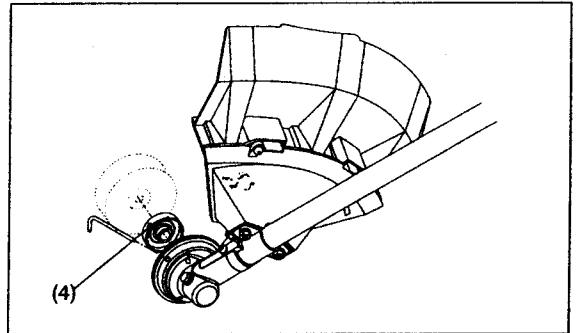

- Then screw the nylon cutting head onto the shaft by turning it counter-clockwise.
- Remove the socket-head wrench.

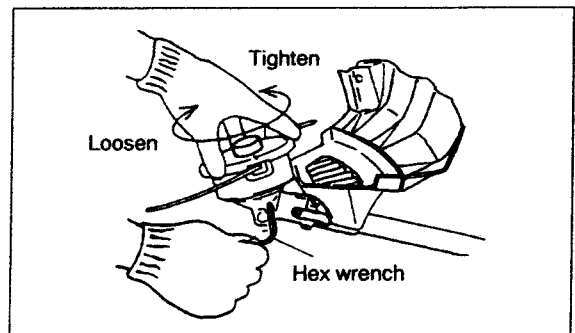

- Make sure that the blade is the left way up.

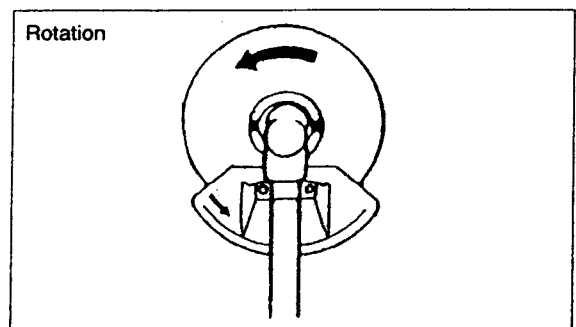

## BEFORE START OF OPERATION

### Inspection and Refill of Engine Oil

- Perform the following procedure, with the engine cooled down.
- While keeping the engine level, remove the oil gauge, and confirm that the oil is filled within the upper and lower limit marks. When the oil is in short in such a way that the oil gauge touches the oil only by its tip, in particular with the oil gauge remaining inserted in the crankcase without screwing-in (Fig. 1), refill new oil near the port (Fig. 2).
- For reference, the oil refill time is about 15 h (refill frequency: 15 times).
- If the oil changes in color or mixes with dirt, replace it with new one. (For the interval and method of replacement, refer to P. 20)

**Recommended oil:** Specified Robin oil, or SAE 10W-30 oil of API Classification, Class SF or higher (4-stroke engine for automobile)  
**Oil volume:** Approx. 0.1 L

**Note:** If the engine is not kept upright, oil may go into around the engine, and may be refilled excessively.  
If the oil is filled above the limit, the oil may be contaminated or may catch fire with white.

#### Point 1 in Replacement of Oil "Oil Gauge"

- Remove dust or dirt near the oil refill port, and detach the oil gauge.
- Keep the detached oil gauge free of sand or dust. Otherwise, any sand or dust adhering to the oil gauge may cause irregular oil circulation or wear on the engine parts, which will result in troubles.
- As an example to keep the oil gauge clean, it is recommended to insert the oil gauge on its knob side into the engine cover, as shown in Fig.3.

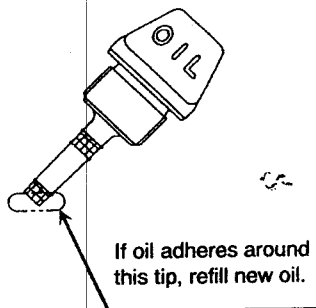

Fig.1

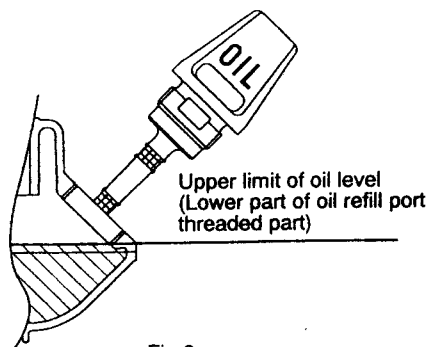

Fig.2

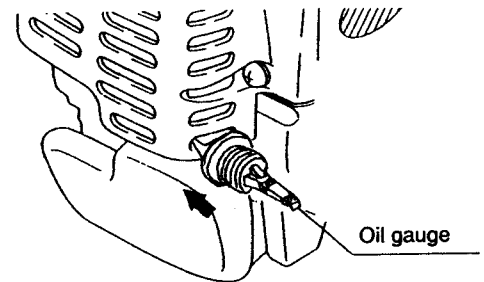
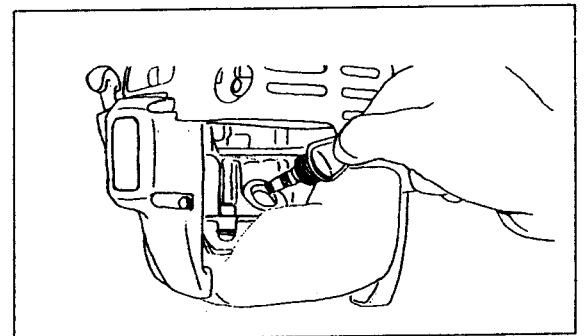
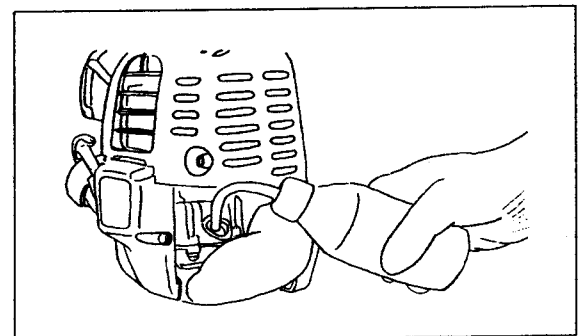

Fig.3

- (1) Keep the engine level, and detach the oil gauge.



- (2) Fill oil up to the edge of the oil refill port. (Refer to Fig.2 of the preceding page).  
Feed oil with the lubricant refill container.



- (3) Securely tighten the oil gauge. Insufficient tightening may cause oil leakage.

#### Point 2 in Replacement of Oil: "If oil spills out"

- If oil spills out between the fuel tank and engine main unit, the oil is sucked into through the cooling air intake port, which will contaminate the engine. Be sure to wipe out spilt oil before start of operation.

## REFUELING

### Handling of Fuel

It is necessary to handle fuel with utmost care. Fuel may contain substances similar to solvents. Refueling must be performed in a sufficiently ventilated room or in the open air. Never inhale fuel vapor, and keep fuel away from you. If you touch fuel repeatedly or for a long time, the skin becomes dry, which may cause skin disease or allergy. If fuel enters into the eye, clean the eye with fresh water. If your eye remains still irritated, consult your doctor.

### Storage Period of Fuel

Fuel should be used up within a period of 4 weeks, even if it is kept in a special container in a well-ventilated shade. If a special container is not used or if the container is not covered, fuel may deteriorate in one day.

### STORAGE OF MACHINE AND REFILL TANK

- Keep the machine and tank at a cool place free from direct sunshine.
- Never keep the fuel in the cabin or trunk.

### Fuel

The engine is a four-stroke engine. Be sure to use an automobile gasoline (regular gasoline or premium gasoline).

### Points for Fuel

- Never use a gasoline mixture which contains engine oil. Otherwise, it will cause excessive carbon accumulation or mechanical troubles.
- Use of deteriorated oil will cause irregular startup.

### Refueling

#### WARNING: INFLAMMABLES STRICTLY PROHIBITED

**Gasoline used:** Automobile gasoline (unleaded gasoline)

- Loosen the tank cap a little so that there will be no difference in atmospheric pressure.
  - Detach the tank cap, and refuel, discharging air by tilting the fuel tank so that the refuel port will be oriented upward. (Never refill fuel full to the oil refill port.)
  - Wipe well the periphery of the tank cap to prevent foreign matter from entering into the fuel tank.
  - After refueling, securely tighten the tank cap.
- If there is any flaw or damage on the tank cap, replace it.
  - The tank cap is consumable, and therefore should be renewed every two to three years.

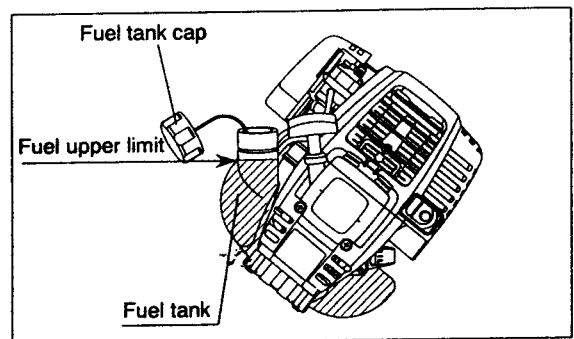

## CORRECT HANDLING OF MACHINE

### Attachment of shoulder strap

- Adjust the strap length so that the cutter blade will be kept parallel with the ground.

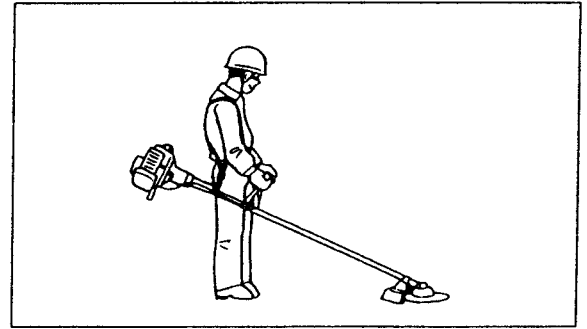

### Detachment

#### For BH3500A

- In an emergency, pull the release belt (1) strongly upward, and you can detach the machine from you.
- Be extremely careful to maintain control of the machine at this time. Do not allow the machine to be deflected toward you or anyone in the work vicinity.

**WARNING:** Failure to maintain complete control of the machine at all could result in serious bodily injury or DEATH.

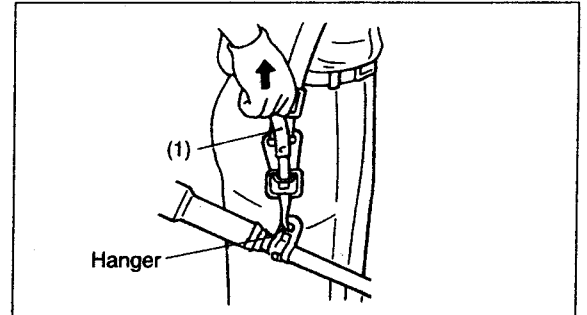

#### For BH3600 AU, BH3500AU

- In case of emergency, remove the emergency detachment lever (2) by pulling strongly with a finger. The machine will detach from body.
- Be extremely careful to maintain control of the machine at this time. Do not allow the machine to be deflected toward you or anyone in the work vicinity.

**WARNING:** Failure to maintain complete control of the machine at all could result in serious bodily injury or DEATH.

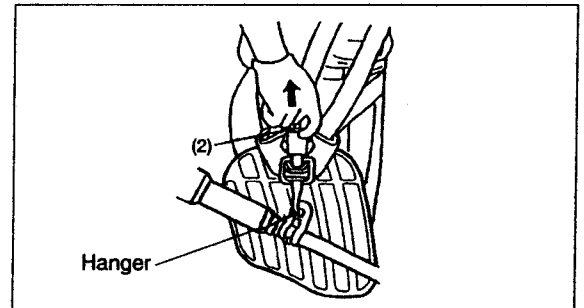

## POINTS IN OPERATION AND HOW TO STOP

Observe the applicable accident prevention regulations!



### STARTING

Move at least 3m away from the place of refuelling. Place the brush cutter on a clean piece of ground taking care that the cutting tool does not come into contact with the ground or any other objects.

#### A: Cold start

- 1) Set this machine on a flat space.

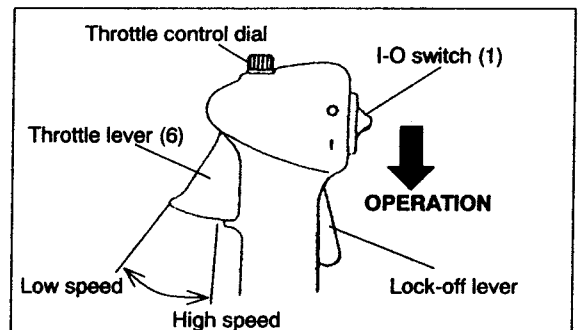

#### For machine with U Handle or Loop Handle

- 1) Set the I-O switch (1) to OPERATION.
- 2) Choke lever
  - Close the choke lever.
  - Choke opening:
    - Full closing in cold or when the engine is cold.
    - Full or half opening in restart just after stop of operation.

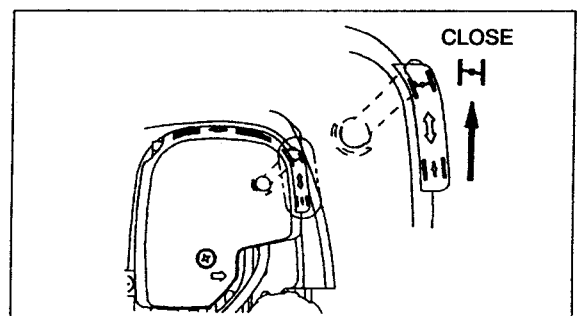

### 3) Primer pump

Continue to push the primer pump until fuel enters into the primer pump. (In general, fuel enters into the primer pump by 7 to 10 pushes.) If the primer pump is pushed excessively, an excess of gasoline returns to the fuel tank.

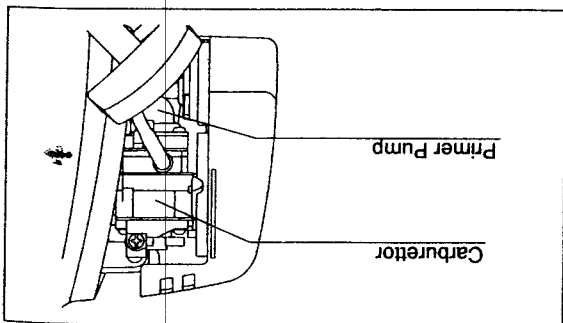

### 4) Recoil starter

— Pull the start knob gently until it is hard to pull (compression point). Then, return the start knob, and pull it strongly.  
— Never pull the rope to the full. Once the start knob is pulled, never release your hand immediately. Hold the start knob until it returns to its original point.

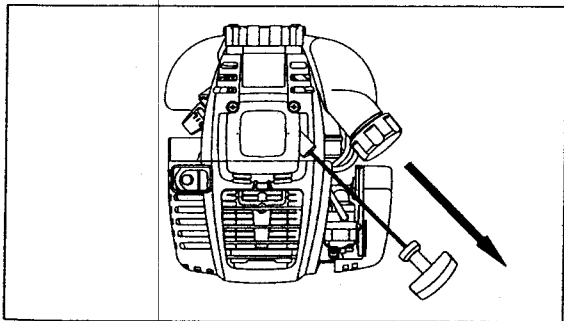

### 5) Choke lever

When the engine starts, open the choke lever.  
— Open the choke lever progressively while checking the engine operation. Be sure to open the choke lever to the full in the end.  
— In cold or when the engine is cooled down, never open the choke lever suddenly. Otherwise, the engine may stop.

### 6) Warm-up operation

Continue warm-up operation for 2 to 3 minutes.

Note: — If the starter handle is pulled repeatedly when the choke lever remains at "START" position, the engine will not start easily due to excessive fuel intake.

— In case of excessive fuel intake, remove the spark plug and pull the starter handle slowly to remove excess fuel. Also, dry the electrode section of the spark plug.

### Caution during operation:

If the throttle lever is opened fully in a no-load operation, the engine rotation is increased to 10,000rpm or more. Never operate the engine at a higher speed than required and at an approximate speed of 6,000 - 8,500rpm.

### B: Startup after warm-up operation

- 1) Push the primer pump repeatedly.
- 2) Keep the throttle lever at the idling position.
- 3) Pull the recoil starter strongly.
- 4) If it is difficult to start the engine, open the throttle by about 1/3. Pay attention to the cutter blade which may rotate.

### Attention in Operation

When the engine is operated upside down, white smoke may come out from the muffler.

### STOPPING

- 1) Release the throttle lever (6) fully, and when the engine rpm has lowered, set the I-O switch to STOP the engine will now stop.
- 2) Be aware that the cutting head may not stop immediately and allow it to slow down fully.

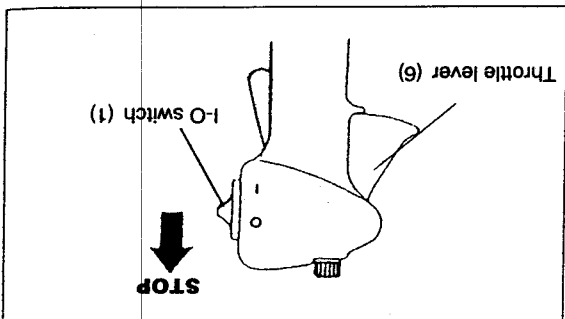

## ADJUSTMENT OF LOW-SPEED ROTATION (IDLING)

When it is necessary to adjust the low-speed rotation (idling), perform it by the carburetor adjusting screw.

### CHECKUP OF LOW-SPEED ROTATION

- Set the low-speed rotation to 3000min<sup>-1</sup>.  
If it is necessary to change the rotation speed, regulate the adjusting screw (illustrated on the left), with Phillips screwdriver.
- Turn the adjusting screw to the right, and the engine rotation will increase.  
Turn the adjusting screw to the left, and the engine rotation will drop.
- The carburetor is generally adjusted before shipment. If it is necessary to readjust it, please contact Authorized Service Agent.

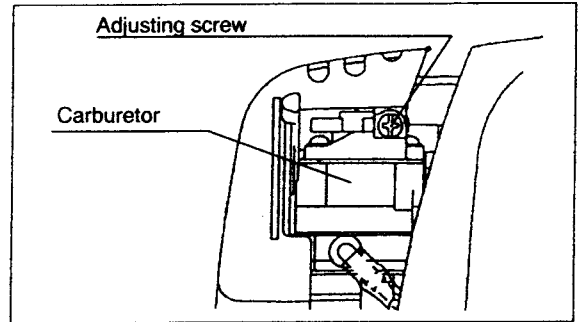

## RESHARPENING THE CUTTING TOOL

**CAUTION:** The cutting tools mentioned below must only be resharpened by an authorized facility. Manual resharpening will result in imbalances of the cutting tool causing vibrations and damage to the equipment.

- cutter blade (star blade (4 teeth), eddy blade (8 teeth), brush blade(3 teeth))  
An expert resharpening and balancing service is provided by Authorized Service Agents.

**NOTE:** To increase the service life of the cutter blade (star blade, eddy blade) it may be turned over once, until both cutting edges have become blunt.

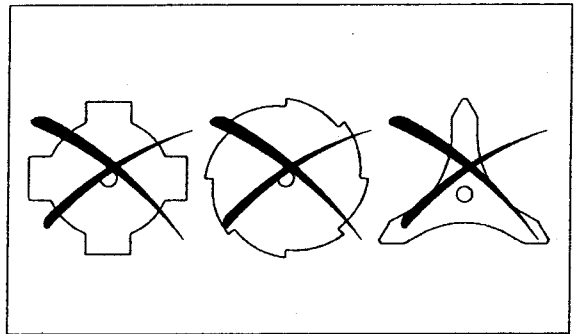

## NYLON CUTTING HEAD

The nylon cutting head is a dual string trimmer head capable of bump & feed mechanisms.

The nylon cutting head will automatically feed out the proper length of nylon cord by the changes in centrifugal force caused by increasing or decreasing RPMS. However, to cut soft grass more efficiently, bump the nylon cutting head against the ground to feed out extra cord as indicated under operation section.

### Operation

- Increase the nylon cutting head speed to approx. 6,000 min<sup>-1</sup>.  
Low speed (under 4,800 min<sup>-1</sup>) is not suitable, the nylon cord will not feed out properly at low speed.
- The most effective cutting area is shown by the shaded area.

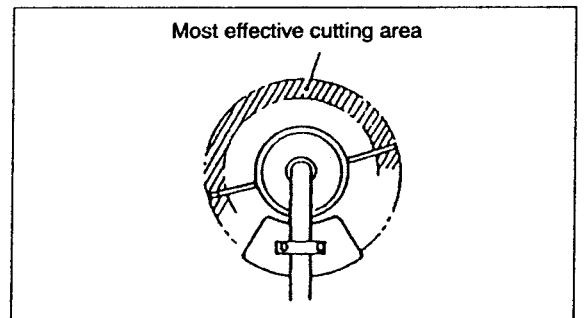

### If the nylon cord does not feed out proceed as follows:

1. Release the throttle lever to run the engine idle and then squeeze the throttle lever fully. Repeat this procedure until the nylon cord feeds out to the proper length.
2. If the nylon cord is too short to feed out automatically with the above procedure, bump the knob of the nylon cutting head against the ground to feed out the nylon cord.
3. If the nylon cord does not feed out with procedure 2, rewind/replace the nylon cord by following the procedures described under "Replacing the nylon cord".

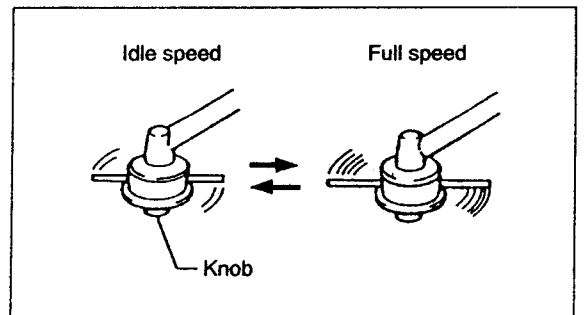

## SERVICING INSTRUCTIONS

**CAUTION:** Before doing any work on the brush cutter, always stop the engine and pull the plug cap off the spark plug (see "checking the spark plug").  
Always wear protective gloves!

To ensure a long service life and to avoid any damage to the equipment, the following servicing operations should be performed at regular intervals.

### Daily checkup and maintenance

- Before operation, check the machine for loose screws or missing parts. Pay particular attention to the tightness of the cutter blade or nylon cutting head.
- Before operation, always check for clogging of the cooling air passage and the cylinder fins. Clean them if necessary.
- Perform the following work daily after use:
  - Clean the brush cutter externally and inspect for damage.
  - Clean the air filter. When working under extremely dusty conditions, clean the filter the several times a day.
  - Check the blade or the nylon cutting head for damage and make sure it is firmly mounted.
  - Check that there is sufficient difference between idling and engagement speed to ensure that the cutting tool is at a standstill while the engine is idling (if necessary reduce idling speed).  
If under idling conditions the tool should still continue to run, consult your nearest Authorized Service Agent.
- Check the functioning of the I-O switch, the lock-off lever, the control lever, and the look button.

### REPLACEMENT OF ENGINE OIL

Deteriorated engine oil will shorten the life of the sliding and rotating parts to a great extent. Be sure to check the period and quantity of replacement.



**ATTENTION:** In general, the engine main unit and engine oil still remain hot just after the engine is stopped. In replacement of oil, confirm that the engine main unit and engine oil are sufficiently cooled down. Otherwise, there may remain a risk of scald.

**Note:** If the oil filled above the limit, it may be contaminated or may catch fire with white smoke.

**Interval of replacement:** Initially, every 20 operating hours, and subsequently every 50 operating hours

**Recommended oil:** Specified Robin oil, or SAE10W-30 oil of API Classification SF Class or higher (4-stroke engine oil for automobile)

In replacement, perform the following procedure.

- 1) Confirm that the tank cap is tightened securely.
- 2) Detach the oil gauge.  
Keep the oil gauge free from dust or dirt.

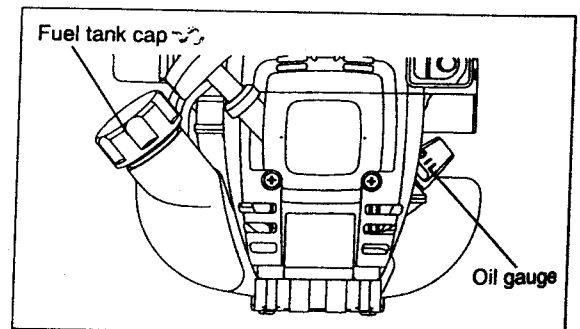

- 3) Place waste or paper near the oil refill port.

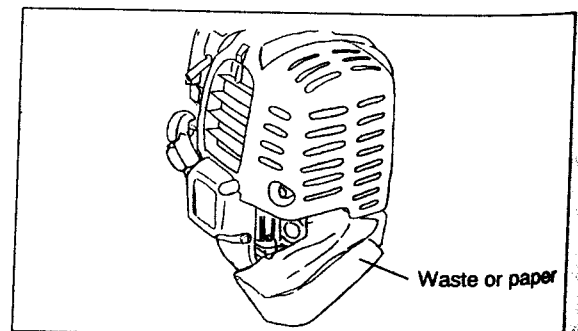

- 4) Detach the oil gauge, and drain oil, tilting the main unit toward the oil refill port.  
Drain oil in a container.

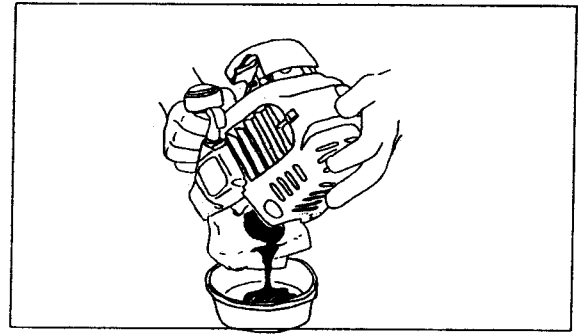

- 5) Keep the engine level, and feed new oil up to the edge of the oil refill port.  
In refill, use a lubricant refill container.  
6) After refill, securely tighten the oil gauge. Insufficient tightening of the oil gauge will lead to oil leakage.

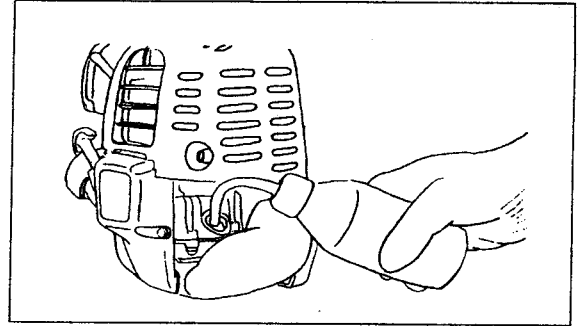

#### POINTS ON OIL

- Never discard replaced engine oil in garbage, earth or sewage ditch. Disposal of oil is regulated by law. In disposal, always follow the relevant laws and regulations. For any points remaining unknown, contact Authorized Service Agent.
- Oil will deteriorate even when it is kept unused. Perform inspection and replacement at regular intervals (replace with new oil every 6 months).

#### CLEANING OF AIR CLEANER



**DANGER: INFLAMMABLES STRICTLY PROHIBITED**

**Interval of Cleaning and Inspection: Daily (every 10 operating hours)**

- Turn the choke lever to the full close side, and keep the carburetor off from dust or dirt.
- Remove the air cleaner cover-fixing bolts.
- Pull the cover lower side and detach the air cleaner cover.
- If oil adheres to the element (sponge), squeeze it firmly.
- For heavy contamination:
  - 1) Remove the element (sponge), immerse it in warm water or in water-diluted neutral detergent, and dry it completely.
  - 2) Clean the element (felt) with gasoline, and dry it completely.
- Before attaching the element, be sure to dry it completely. Insufficient drying of the element may lead to difficult startup.
- Wipe out with waste cloth, oil adhering around the air cleaner cover and plate breather.
- Immediately after cleaning is finished, attach the cleaner cover and tighten it with fixing bolts. (In remounting, first place the upper claw, and then the lower claw.)

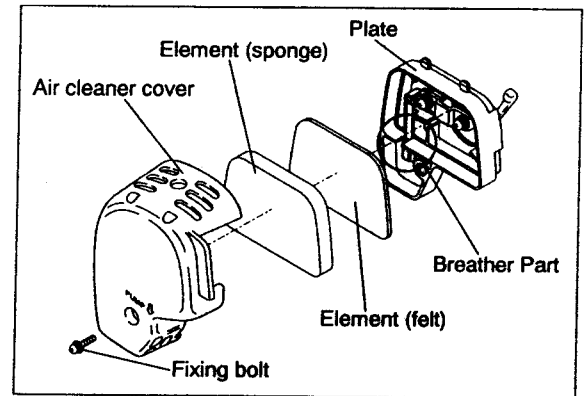

#### Points in Handling Air Cleaner Element

- Clean the element several times a day, if excessive dust adheres to it.
- If operation continues with the element remaining not cleared of oil, oil in the air cleaner may fall outside, resulting in oil contamination.

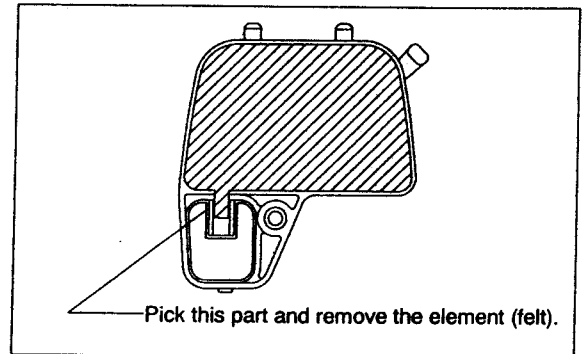

## CHECKING THE SPARK PLUG

- Only use the supplied universal wrench to remove or to install the spark plug.
- The gap between the two electrodes of the spark plug should be 0.7-0.8mm (0.028"-0.032"). If the gap is too wide or too narrow, adjust it. If the spark plug is clogged with carbon or fouled, clean it thoroughly or replace it.

CAUTION: Never touch the spark plug connector while the engine is running (danger of high voltage electric shock).

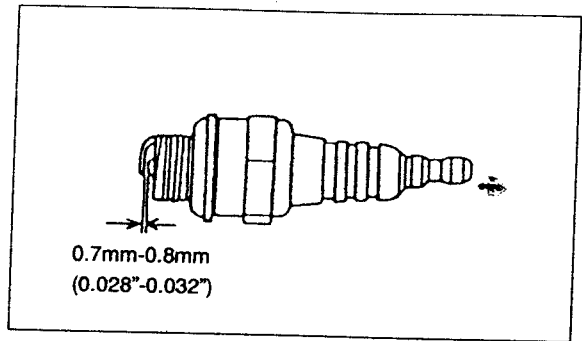

## SUPPLY OF GREASE TO GEAR CASE

- Supply grease (Shell Alvania 2 or equivalent) to the gear case through the grease hole every 30 hours. (Genuine ROBIN grease may be purchased from your ROBIN dealer.)

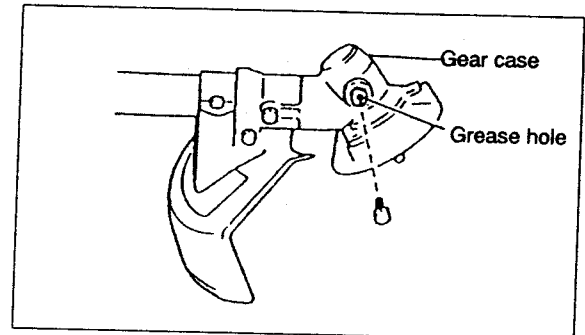

## CLEANING OF FUEL FILTER

### WARNING: INFLAMMABLES STRICTLY PROHIBITED

Interval of Cleaning and Inspection: Monthly (every 50 operating hours)

#### Suction head in the fuel tank

- The fuel filler (1) of the suction head is used to fill the fuel required by the carburetor.
- A periodical visual inspection of the fuel filter is to be conducted. For that purpose open the tank cap, use a wire hook and pull out the suction head through the tank opening. Filters found to have hardened, been polluted or clogged up are to be replaced.
- Insufficient fuel supply can result in the admissible maximum speed being exceeded. It is therefore important to replace the fuel filter at least quarterly to ensure satisfactory fuel supply to the carburetor.

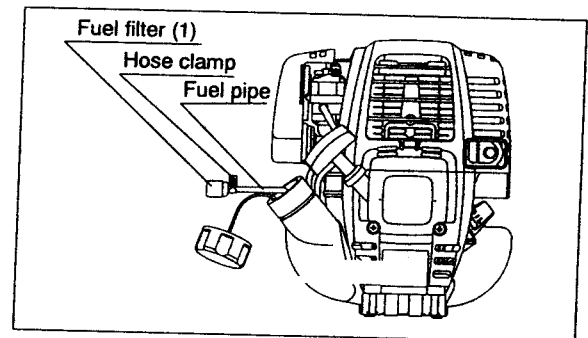

## REPLACEMENT OF FUEL PIPE

### CAUTION: INFLAMMABLES STRICTLY PROHIBITED

Interval of Cleaning and Inspection: Daily (every 10 operating hours)  
Replacement: Annually (every 200 operating hours)

Replace the fuel pipe every year, regardless of operating frequency. Fuel leakage may lead to fire.

If any leakage is detected during inspection, replace the oil pipe immediately.

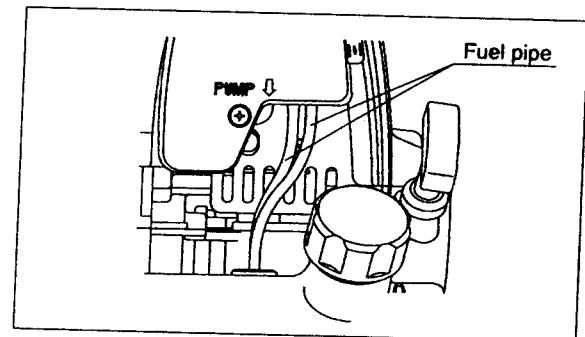

## INSPECTION OF BOLTS, NUTS AND SCREWS

- Retighten loose bolts, nuts, etc.
- Check for fuel and oil leakage.
- Replace damaged parts with new ones for safety operation.

## CLEANING OF PARTS

- Keep the engine always clean.
- Keep the cylinder fins free of dust or dirt. Dust or dirt adhering to the fins will cause seizure.

## REPLACEMENT OF GASKETS AND PACKINGS

In reassembling after the engine is dismantled, be sure to replace the gaskets and packings with new ones.

Any maintenance or adjustment work that is not included and described in this manual is only to be performed by Authorized Service Agents.

## STORAGE



**WARNING:** When draining the fuel, be sure to stop the engine and confirm that the engine cools down.

Just after stopping the engine, it may still hot with possibility of burns, inflammability and fire.



**ATTENTION:** When the machine is kept out of operation for a long time, drain up all fuel from the fuel tank and carburetor, and keep it at a dry and clean place.

- Drain up fuel from the fuel tank and carburetor according to the following procedure:
  - 1) Remove the fuel tank cap, and drain fuel completely.  
If there is any foreign matter remaining in the fuel tank, remove it completely.
  - 2) Pull out the fuel filter from the refill port using a wire.
  - 3) Push the primer pump until fuel is drained from there, and drain fuel coming into the fuel tank.
  - 4) Reset the filter to the fuel tank, and securely tighten the fuel tank cap.
  - 5) Then, continue to operate the engine until it stops.
- Remove the spark plug, and drip several drops of engine oil through the spark plug hole.
- Gently pull the starter handle so that engine oil will spread over the engine, and attach the spark plug.
- Attach the cover to the cutter blade.
- During storage, keep the rod horizontal or keep the machine upright with the blade edge oriented upward. (In this case, pay full attention to prevent the machine from falling.)  
Never store the machine with the cutter blade edge oriented downward. Lubricating oil may spill out.
- Keep the drained fuel in a special container in a well-ventilated shade.

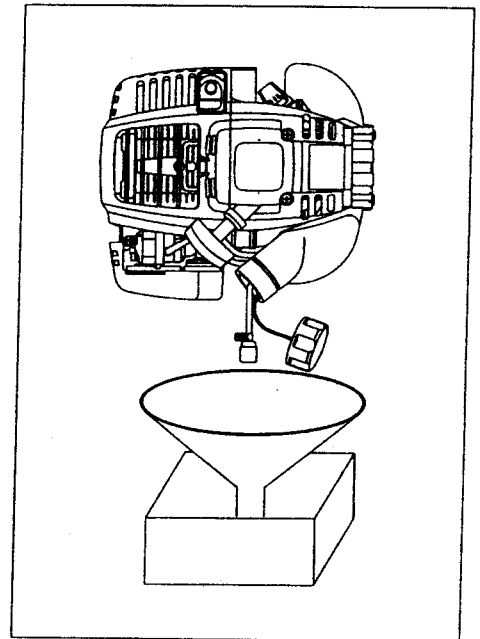

### Attention after long-time storage

- Before startup after long-time shutdown, be sure to replace oil (refer to P 18). Oil will deteriorate while the machine is kept out of operation.

### Fault location

Fault	System	Observation	Cause
Engine not starting or with difficulty	Ignition system	Ignition spark O.K.	Fault in fuel supply or compression system, mechanical defect
		No ignition spark	STOP-switch operated, wiring fault or short circuit, spark plug or connector defective, ignition module faulty
	Fuel supply	Fuel tank filled	Incorrect choke position, carburetor defective, fuel supply line bent or blocked, fuel dirty.
	Compression	No compression when pulled over	Cylinder bottom gasket defective, crankshaft seals damaged, cylinder or piston rings defective or improper sealing of spark plug
Warm start problems	Mechanical fault	Starter not engaging	Broken starter spring, broken parts inside of the engine
		Tank filled ignition spark existing	Carburetor contaminated, have it cleaned
Engine starts but dies	Fuel supply	Tank filled	Incorrect idling adjustment, carburetor contaminated
Insufficient performance	Several systems may simultaneously be affected	Engine idling poor	Fuel tank vent defective, fuel supply line interrupted, cable or STOP-switch faulty
			Air filter contaminated, carburetor contaminated, muffler clogged, exhaust duct in the cylinder clogged

Item	Operating time		Operating time							Corresponding P	
			Before operation	After lubrication	Daily (10h)	30h	50h	200h	Shutdown /rest		
Engine oil		Inspect/clean	○								15
		Replace									
Tightening parts (bolt, nut)		Inspect	○					○*1			20
											22
Fuel tank		Clean/inspect	○								—
		Drain fuel									—
Throttle lever		Check function		○					○*3		23
Stop switch		Check function		○							17
Cutting blade		Inspect	○		○						17
Low-speed rotation		Inspect/adjust			○						13
Air cleaner		Clean			○						19
Ignition plug		Inspect			○						21
Cooling air duct		Clean/inspect			○						22
Fuel pipe		Inspect			○						22
		Replace									22
Gear-case grease		Refill						◎*2			—
Fuel filter		Clean/replace			○						22
Clearance between air intake valve and air discharge valve		Adjust					○				22
Oil tube		Inspect						◎*2			—
Engine overhaul								◎*2			—
Carburetor		Drain fuel						◎*2			—
									○*3		23

- \*1 Perform initial replacement after 20h operation.  
 \*2 For the 200 operating hour inspection, request Authorized Service Agent or a machine shop.  
 \*3 After emptying the fuel tank, continue to run the engine and drain fuel in the carburetor.

Machine Type: 05 999

vibe shaft 2" motorised Porta



# Flextool



Manual # 376

---

## PortaVibe

Risk assessment # 275 - petrol/diesel driven portable plant.

### ECCENTRIC TYPE CONCRETE VIBRATOR

---

### OPERATING INSTRUCTIONS

---

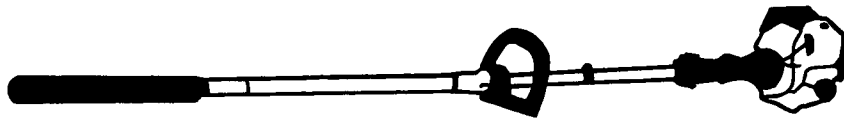

#### WARNING

To reduce the risk of injury, all operators and maintenance personnel must read and understand these instructions before operating, changing accessories, or performing maintenance on Flextool power equipment. All possible situations cannot be covered in these instructions. Care must be exercised by everyone using, maintaining or working near this equipment.

## CONTENTS

Introduction .....	2
Applications .....	2
Assembly .....	2
Functions and controls .....	2
Hazards and risks .....	2-3
Operation .....	3
Care and preventive maintenance.....	3
Cleaning and storage .....	4
Warranty .....	4
Spare parts and service .....	4

## INTRODUCTION

### General Safety Instructions for the Operation of Power Equipment

The goal of Flextool is to produce power equipment that helps the operator work safely and efficiently. The most important safety device for this or any tool is the operator. Care and good judgement are the best protection against injury. All possible hazards cannot be covered here, but we have tried to highlight some of the important items. Individuals should look for and obey Caution, Warning and Danger signs placed on equipment, and displayed in the workplace. Operators should read and follow safety instructions packed with each product.

Learn how each machine works. Even if you have previously used similar machines, carefully check out each machine before you use it. Get the "feel" of it and know its capabilities, limitations, potential hazards, how it operates, and how it stops.

## APPLICATIONS

Civil: roadways, kerbing, pre cast beams, bridge decks, piers.

Commercial building: strip and raft foundations, stairs, walls, floors, driveways, suspended slabs, tilt panels, stack cast panels.

Residential building: floor stumps, wall cavities, house slabs, wall footings, paving slabs.

Rural: fence posts, stock troughs and pens.

## ASSEMBLY

If the unit was supplied unassembled the following must be completed prior to operation:

The unit is supplied with the flexible shaft disconnected from the motor unit. To attach the flexible shaft, place the threaded ferrule end of the flexible shaft approximately 20 mm from the coupling housing. Engage the squared end of the flexible shaft core assembly into the squared seal sleeve adaptor.

The threaded ferrule end of the flexible shaft may now be screwed into the motor adaptor. Rotate the ferrule end of the flexible shaft in an anti-clockwise direction to engage the left hand thread. Once tightened by hand use multigrip pliers to ensure the ferrule is tightened sufficiently to stop it from working loose and coming detached during operation.

A 1 litre container of Honda 10W/30 engine oil is included with the unit. Engine oil capacity is 100 ml. To add oil place the unit on a level surface and remove the oil filler cap. Add oil until the oil level reaches the edge of the oil filler neck & reinstall the oil filler cap.

Fuel may now be added and the unit is ready for operation.

## FUNCTIONS AND CONTROLS

### Drive Unit

This portable drive unit is designed to power flexshaft drive, eccentric vibrators.

The motor is controlled by an ON/OFF push button which is mounted below the throttle lever on the handle.

The motor speed is controlled by throttle lever mounted on the handle.

A centrifugal clutch is fitted to the motor which disengages the drive to the vibrator when the motor is idling.

The clutch operates automatically and requires no adjustment.

The motor is a **4-stroke** unit and must only be used with **unleaded** petrol.

### Vibrator

This vibrator is designed for the compaction of concrete by immersion of the vibrator head. Compaction improves the strength and finish of concrete by driving out entrapped air. High frequency vibration allows the efficient compaction of low slump concrete mixes.

The vibrator head is driven by a rotating flexible drive shaft that transmits the drive from the drive unit.

The vibrator head uses an eccentric mass to produce vibration. Ball bearings support the rotor at each end.

## HAZARDS AND RISKS

**NEVER** allow any person to operate equipment without adequate instruction.

**ENSURE** all operators read, understand and follow the operating instructions.

**SERIOUS INJURY** may result from improper or careless use of this machine

### ! MECHANICAL HAZARDS

**DO NOT** operate the machine unless all protective guards are in place.

**ENSURE** that the motor operation switch is in the OFF position and the spark plug ignition lead is disconnected before removing the guards or making adjustments.

**KEEP** hands and feet clear of rotating and moving parts as they will cause injury if contacted.

**DO NOT** leave the equipment in operation while it is unattended.

**EXERCISE CARE** when handling vibrators. Exposure to vibration or repetitive work actions may be harmful to hands and arms.

**DO NOT** hold the vibrator shaft in your hands while it is running. Hold the vibrator by the "D" handle & use the supplied carry strap to help isolate your hands from the vibration.

**NEVER** stand on the vibrating head while it is operating.

**DO NOT** place your foot on the vibrator head while it is running unless it is done momentarily and the vibrator head is resting on a resilient support such as a car tyre.

**BE CAREFUL** not to come in contact with the muffler when the engine is hot, since it can cause severe burns.

**ENSURE** that repairs to machinery are carried out by **COMPETENT** personnel.

### **! FIRE & EXPLOSION HAZARDS**

**PETROL** is extremely flammable and explosive under certain conditions.

**ENSURE** that petrol is only stored in an approved storage container.

**DO NOT** refuel the motor while it is in operation or hot.

**DO NOT** refuel the motor in the vicinity of sparks, a naked flame or a person smoking.

**DO NOT** over fill the fuel tank and avoid spilling petrol when refuelling. Spilled petrol or petrol vapour may ignite. If spillage occurs, ensure that the area is dry before starting the motor.

Motor vibrations can cause an improperly tightened fuel cap to loosen or come off and spill quantities of fuel. In order to reduce risk of fuel spillage and fire, tighten fuel cap by hand with as much force as possible.

To reduce the risk of serious injury from burns, never attempt to refuel the unit until it has been stopped & completely removed from the operator.

### **! CHEMICAL HAZARDS**

**DO NOT** operate or refuel a petrol motor in a confined area without adequate ventilation

**CARBON MONOXIDE** exhaust gases from internal combustion motor driven units can cause death in confined spaces.

### **! NOISE HAZARDS**

**EXCESSIVE NOISE** can lead to temporary or permanent loss of hearing.

**WEAR** an approved hearing protection device to limit noise exposure, as required by Occupational Health and Safety regulations. Noise levels in excess of 87dB(A) may be produced by engines and vibrators.

### **PROTECTIVE CLOTHING**

**ALWAYS** wear protective clothing and footwear to prevent the skin coming into contact with wet concrete.

**PROTECTIVE FOOTWEAR** should be worn to reduce injuries from penetration through the sole, contact with cutting objects, slipping, contact with wet concrete and electrical hazards.

**GOGGLES** for eye protection may also be necessary.

**USE** waterproof protection for hands and knees (if kneeling) when concreting. If your clothing becomes wet from concrete contact make sure you change the clothing. Do not walk about waiting for it to dry.

**USE GLOVES** when handling and inspecting the flexible shaft outer casing. Excessive wear of the rubber cover can expose the wire braided reinforcement, allowing it to project and cause injury.

### **! ADDITIONAL HAZARDS**

To reduce the risk of injury from loss of balance, start the motor with the unit on a flat level surface, and only pick up the unit when the engine is idling.

Slip/Trip/Fall is a major cause of serious injury or death. Beware of the flexible shaft and water left on the walking or work surface.

Exercise caution and ensure that the perimeter of elevated formwork or platforms is protected.

Exercise care when working in the vicinity of unprotected holes or excavations

### **OPERATION**

To start the motor, place the unit on a flat level surface, and only pick up the unit when the engine is idling.

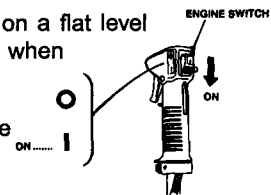

To start the motor turn the engine switch to the ON position.

To start a cold engine, move the choke lever to the closed position

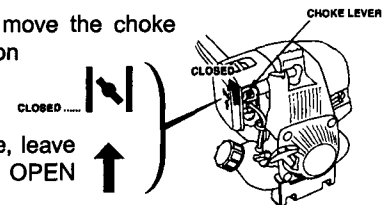

To restart a warm engine, leave the choke lever in the OPEN position.

Press the priming pump several times until a flow in the fuel return tube is visually noticed.

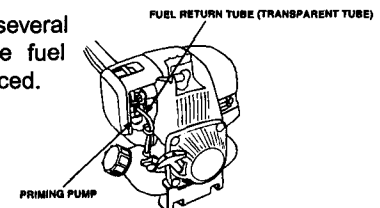

Pull the starter grip lightly until you feel resistance while holding the unit steady, then pull briskly. Return the starter grip gently.

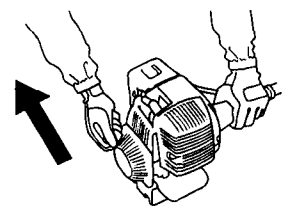

If the choke lever is in the CLOSED position, gradually move it to the OPEN position as the engine warms up.

The idle-up function helps the engine start by opening the throttle valve in the carburetor moderately when the engine won't start.

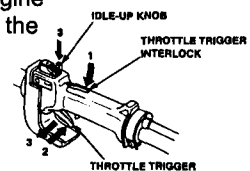

1. Hold down the throttle interlock.
2. Pull the throttle trigger.
3. Push the idle-knob, then release the throttle trigger and the interlock.
4. Start the engine

**NOTE:** This function must not be used when vibrating.

Always operate the unit at full throttle. This will ensure correct concrete compaction and avoid damage to the drive mechanism.

Be careful starting and or revving the unit on loose gravel as it may be sucked into the flywheel cooling fins causing damage to the unit.

Information regarding compaction of concrete using immersion vibrators is available in a FLEXTOOL FACT SHEET.

Avoid sharp bends in the flexshaft, particularly when it is in use.

Do not use a eccentric-type immersion vibrator head as an external vibrator by applying it to the outside of formwork.

Do not operate the vibrating head out of concrete for extended periods. Do not leave it running while you wait for fresh supplies of concrete to be placed. Vibrator heads are designed to be cooled by the concrete in which they are immersed.

## CARE AND PREVENTIVE MAINTENANCE

Keep the unit clean and free of concrete residue.

Check the oil level in the engine crankcase daily, it should reach the edge of the oil filler neck. The engine oil capacity is only 100 ml and running the engine with a low oil level will cause serious engine damage.

Vibrators must be handled with care, and be properly maintained in order to avoid unnecessary breakdowns. Check regularly for signs of wear and rectify any faults immediately.

The exterior of the flexshaft and the vibrator head are subject to abrasion and wear. If the vibrator is operated unchecked, concrete will eventually enter the vibrator head or the flexshaft. Naturally, the cost of repairing, a vibrator which has been allowed to deteriorate in this way will be greater.

Regular inspection of the vibrator and the flexible shaft will avoid these problems.

Check the flexible shaft for kinks and external damage by laying it out straight on a workbench or the floor. Although it still operates, a badly kinked flexible shaft may result in a broken inner core.

Check the outer casing rubber cover for damage where it enters the ferrule at the vibrator head. Damage is caused by operators using a crane to retrieve a vibrator trapped in concrete reinforcing bars.

## SERVICE

Replace the oil in the motor crankcase regularly with Honda 10W/30 oil.

The air cleaner element fitted is a wet foam type. Service the air cleaner element regularly by washing the element in a non flammable solvent and let it dry thoroughly. Soak the element in clean engine oil, squeeze out the excess oil and reinstall the air cleaner element.

A fuel tank strainer is fitted to the unit. A clogged filter may cause poor engine performance requiring the fuel filter to be removed from the fuel tank and cleaned.

Inspect, clean and/or replace the spark plug regularly.

## CLEANING AND STORAGE

It is advisable to wash the vibrator head and flexshaft with clean water after use each day and before storing. This will ensure that concrete does not accumulate on the exterior.

Ensure the cooling fins on the motor are kept unobstructed.

## SPECIFICATIONS

<b>Motor</b>	Honda, 35 cc 4-stroke petrol	
<b>Motor Oil Capacity</b>	100 ml	
<b>Model</b>	PVE44	PVE44R
<b>Type</b>	Hard Nose	Resilient Nose
<b>Part No.</b>	F03330	F03331
<b>Frequency</b>	9,000	9,000
<b>Amplitude</b>	2.8 mm	2.8 mm
<b>Head Dia.</b>	44 mm	44 mm
<b>Weight</b>	11 kg	11 kg

## WARRANTY

FLEXTOOL products are covered by warranty for a period of six (6) months from the date of purchase against defects in material or workmanship provided that:

- the product concerned has been operated and maintained in accordance with the operating instructions.
- has not been damaged by accident, misuse or abuse.
- has not been tampered with or repaired by any unauthorised person.

The owner is responsible for the cost of transportation to and from the authorised repairer and the unit is at the owners risk while in transit to and from the repairer.

## SPARE PARTS AND SERVICE

**FLEXTOOL (AUST.) PTY. LTD.** ABN 11 004 502 961  
**Melbourne** Head Office  
P.O. Box 1102 **Tel: (03) 9419 6300**  
191 Wellington Street **Fax: (03) 9417 1391**  
Collingwood Vic. 3066  
Australia

**Sydney**  
Unit 1, 52 Heathcote Road **Tel: (02) 9601 1422**  
Moorebank N.S.W. 2179 **Fax: (02) 9824 3077**

**Brisbane**  
17 Ross street **Tel: (07) 3252 2306**  
Newstead Qld. 4006 **Fax: (07) 3252 5359**

**Adelaide**  
68 Daws Road **Tel: (08) 8374 4300**  
Edwardstown S.A. 5039 **Fax: (08) 8374 4194**

**Perth**  
Unit 3, 47 Tate Street **Tel: (08) 9451 2077**  
Bentley W.A. 6102 **Fax: (08) 9350 5011**

**Free Call**  
Outside the above **Tel: 1800 801 108**  
metropolitan areas.

**Internet** [www.flextool.com.au](http://www.flextool.com.au)  
[sales@flextool.com.au](mailto:sales@flextool.com.au)