

M: 687

06101

Reo Bender up to 16mm.

RB-16

ELECTRIC REBAR BENDER

HANDLING INSTRUCTIONS

READ THESE INSTRUCTIONS CAREFULLY BEFORE ATTEMPTING TO USE. Ignorance of proper operating procedures can lead to accidents. If in doubt about any procedure, contact your nearest authorized distributor.

CONTENTS

General Safety Precautions

Parts and specifications

Operating Instructions

Pre-use checks

Warm-up

Stopper adjustment

Points of attention

Maintenance

Cleaning

Oil-level check

Oil change

Bolt tightness

Carbon brushes

GENERAL SAFETY PRECAUTIONS

USAGE

Use RB-16 rebar bender on concrete re-inforcing bars only.

RESRICT USE TO DESIGNATED MATERIALS

Don't use the machine to bend very hard rebar. The hard rebar may break and will also damage the tool. Do not attempt to bend rebars. Harder, thicker or thinner than those specified (see page 5).

USE EYE PROTECTION

Wear safety goggles, safety glasses with side shields or a face shield while using bender.

PROVIDE SAFETY BARRIERS

Erect safety screens to protect co-workers from possible flying ends. Place safety screen under the rebar when working in high places.

GUARD AGAINST ELECTRIC SHOCK

To avoid possible electric shock, do not handle bender with wet hands or use bender in the rain or damp places. Be aware of all power lines, electric circuits and other hazards that may be contacted, especially those that are below the surface or otherwise hidden from view.

UNPLUG TOOL

Disconnect bender from outlet while not in use and before cleaning, adjusting or servicing. Do not disconnect plug from outlet by pulling the cord. Always check that the switch lock is OFF before plugging in.

BEWARE OF ENVIRONMENT

Do not use bender in the presence of flammable materials (e . G . Paint, thinner, petroleum products , adhesives) .

Do not use bender in a possibly lighted and clear of obstructions. Operator should at all times have an unobstructed view of the cutter, rebar and surrounding area.

WEAR PROPER APPAREL

Do not wear loose clothes, dangling objects or jewellery. Restrain long hair.

The use of a safety-helmet and rubber soled boots is recommended. If safety gloves are worn, be especially careful that gloves does not get caught in moving parts

KEEP VISITORS AWAY

Keep all visitors at a safe distance from the work area for their own protection

And to prevent distraction of the operator.

MAINTAIN BENDER WITH CARE

Inspect bender before each application. Keep handle dry, clean and free from oil and/or grease. Keep housing and piston free of dirt and iron filings. Check that no screws or bolts are loose or missing. Following instructions for maintenance. Inspect switch, cord, Plug and any extension cable at regular intervals.

STORE CAREFULLY

When not in use, store bender and accessories in a dry place where they can't be accessed by unauthorized persons.

PARTS AND SPECIFICATIONS

- 1.Head
- 2.Bend blocks
- 3.Adjustable stopper
- 4.Side handle (detachable)
- 5.Cylinder
- 6.Oil case
- 7.Pump case
- 8.Oil-plug
- 9.Carbon brush holder
- 10.Carbon brush
- 11.Switch
- 12.Plastic house
- 13.Motor
- 14.Switch
15. bending piston

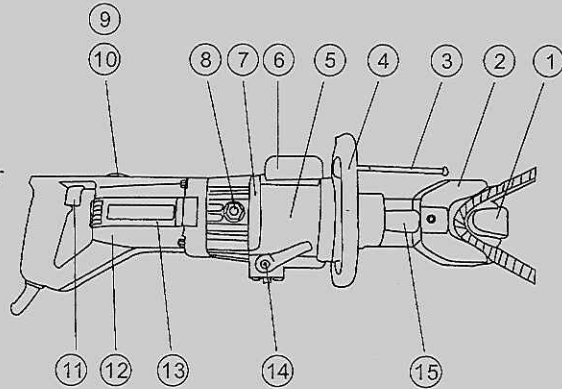

Main Parameters

Model	RB-16
Voltage + 5%	<input type="checkbox"/> 100/115V <input type="checkbox"/> 230V AC only
Wattage	<input type="checkbox"/> 800 W <input type="checkbox"/> 750 W
Dimensions	600*170*200 mm
Weight	15 Kg
Max.rebar diameter	16mm
Min.rebar diameter	4mm
Max.rebar hardness	Tensile strength 650N/mm ²
Bending speed	5.0 secretary.

OPERATING INSTRUCTIONS

! CAUTION: Indicates hazard that could result in minor personal injury and/or product damage.

CARE: Indicates hazard that will result in product damage.

PRE-USE CHECKS

Check oil level.

Check condition of bender blocks and tightness of bender block bolts.

Check that the power source is appropriate to the bender

CARE: if voltage is too high, the motor will burn out. If the voltage is too

Low, insufficient power will be generated. Never use DC power.

Check that power supply is properly earthed.

! CAUTION: Failure to earth power supply may result in electric shock to operator.

Check that cord is undamaged and that plug is not loose.

If an extension cable is to be used, make sure that it is undamaged and that it is the proper thickness for the length. See table below.

Cable length	110/115V	230V
	Cable size (AWG)	Nominal diameter
Up to 10m (33 ft)	16	1.0mm ²
Up to 15m (50 ft)	14	1.25mm ²
Up to 30m (100 ft)	10	1.5mm ²

6. Before plugging in, make sure that the switch lock is OFF.

WARM-UP

In cold weather, warm up unit for 30~60 seconds so that the hydraulic oil reaches the proper viscosity. Pull trigger-switch to extend piston and release when it has reached its full stroke. Repeat 15~20 times.

POINTS OF ATTENTION

1. Do not cover air vents.

CARE: If events are covered, motor will overheat and may burn out.

2. If hydraulic oil exceeds 70.(158.F) in temperature, power will drop. Allow unit to cool before resuming operation. (Be particularly careful in summer, when the aluminium pump case heats up quicker.)

3. If a drop in power is observed and motor is unusually hot, check carbon-brushes.

4. Pull the # 14 part valve to make the bending piston return back to tally after each bending.

MAINTENANCE

CLEARING

Cleaning bender every day, preferably immediately after use.

!CAUTION: Wear gloves to protect hands from metal splinters. Do not use an air-gun: blasting with air can cause metal filings and /or dust to get into eyes and respiratory system.

Disconnect unit.

Wipe or brush away all dirt and metal filings. Pay particular attention to the lower half of the piston, where dirt is more easily accumulated.

OIL-LEVEL CHECK

As the bender is hydraulically operated, the oil-level must be checked at frequent intervals, preferably every day. Failure to maintain the oil at the proper level results in a drop in pressure and loss of bending power

!CAUTION: Hydraulic oil is highly flammable. Keep away from sparks and naked flame. Do not smoke.

!CAUTION: Hydraulic oil may cause inflammation of the eyes and skin.

If ingested, it will cause diarrhoea and vomiting.

In case of eye contact, rinse in clean water for at least 15 minutes

And consult a physician.

In case of skin contact, wash thoroughly with soap and water.

In case of ingestion, consult a physician immediately. Do not Deliberately induce vomiting.

1. Oil should be warm but not hot. Warm up unit if cold.

2. Adjust stopper and make three or four cuts, noting exactly at what point the Rebar is actually breaking.

3. Pinch a short piece of rebar, stopping just before it breaks off. Unplug unit From power source.

4. With partially severed rebar in place, turn unit over so that oil-plug is uppermost. (If unit is hot, allow to cool down.)

5. Remove oil-plug and seal-washer (packing).

!CAUTION: Never remove oil-plug when unit is hot or oil will spurt out.

6. Check that oil is level with bottom of plug hole (i.e. that pump case is full to the brim). If oil level is too low, top up with 20-weight hydraulic oil with Anti-foam and anti-abrasion properties (ISO viscosity grade VG46, e.g. Shell Oil Tellus 46, Mobil oil DTE-25 or Esso Uni power SQ46).

7. After topping up, extract air from system. Gently tilt cutter lengthwise

and Return it to a level position. Top up again and tilt in the opposite direction. Repeat this process until all air has been extracted. CARE: Bender cannot function properly if oil contains air bubbles.

8. Replace seal washer (packing) and plug. Connect cutter to power source and completely sever rebar.

OIL-CHANGE

1. The hydraulic oil should be changed at least once a year, sooner if it appears dirty. Unplug unit from power source. Remove oil - plug and packing. Turn bender Over and drain oil into a suitable receptacle. When oil ceases to drain out, tilt unit to rear so that oil trapped in the piston housing can run out. When housing is empty, tilt unit in the opposite direction to empty the residue in the pump case.

2. With drain-hole uppermost, slowly fill the unit with fresh oil. Replace plug And lightly tighten. Connect unit to power source and advance piston two or three times. Unplug unit and remove oil-plug. Top up oil level and replace plug.

3. Finally, follow procedure for oil-level check. (Steps 2~8.)

Note: Dispose of hydraulic oil in accordance with local regulations. Do not Pour into the sea, a river, a lake or drains.

BOLT TIGHTNESS

Once a week, or after every 500 bends, check the tightness of all bolts, especially those securing the housing to the cylinder. Loose bolts will result in a loss of power.

CARBON BRUSHES

Inspect the two carbon brushes at least once every two months, (Nominal brush life is 200 hours).

CARE: worn brushes will result in power loss, cause the motor to run hot And irreparably damage the armature's commutator.

1. Disconnect unit.
2. Unscrew both brush caps and pull out carbon brushes.
3. Replace brushes if less than 6 cm in length.