

LEISTER Triac S

Hot Air Blower

Order No. 1G3, 1G4



Read operating instructions carefully before use and keep it for further reference.



APPLICATION

- **Welding** of thermoplastic materials as well as single-ply flexible plastics and modified bitumen in the form of boards, tubes, profiles, lining membranes, coated materials, films, foams, tiles, and sheets. The following procedures are possible: overlap welding, welding with rod, with tape, butt welding and melt welding
- **Heating-up** for forming, bending and sealing of thermoplastic semi-finished materials and plastic granules
- **Drying** of water-damp surfaces
- **Shrinking** of heat-shrink sleeves, films, tapes, solder sleeves, pre formed and moulded parts
- **Soldering** of copper pipes, solder joints and metal foils
- **Defrosting** of frozen water pipes
- **Activating/dissolving** of solvent free adhesives and fusion adhesives
- **Igniting** of wood shavings, paper, coal or straw in furnaces

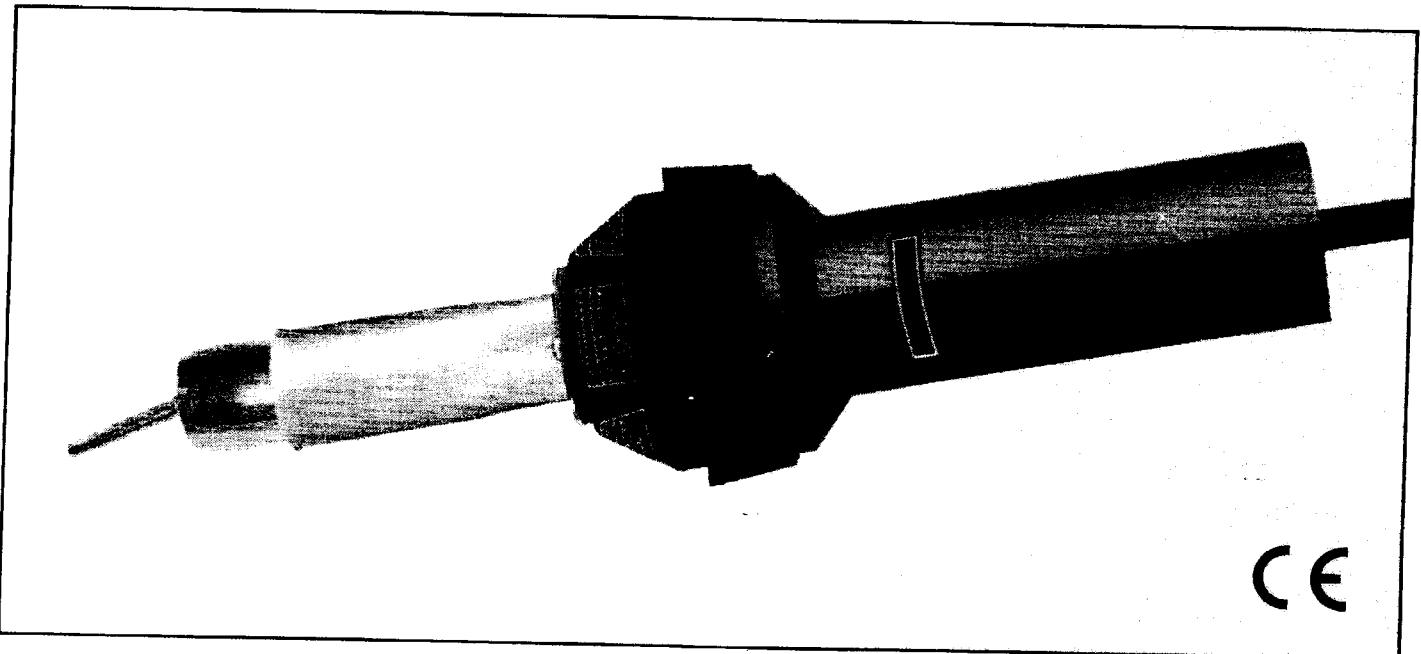



WARNING



Danger to life when opening the tool, as live components and connections are exposed. Unplug the tool before opening it.



Incorrect use of hot air blowers can cause **fire and explosion hazard**, especially near combustible materials and explosive gases.



Do not touch the element housing and nozzle when they are hot as they can cause **burns**. Let the tool cool down. Do not point hot air flow in the direction of people or animals.



CAUTION



The **voltage rating** stated on the tool must correspond to the line/mains voltage.



For personal protection on building sites we strongly recommend the tool be connected to a **GFCI** (Ground Fault Circuit Interrupter) or a **RCCB** (Residual Current Circuit Breaker).



The tool must be operated **with supervision**. Heat can reach combustible materials, which are out of sight.



Protect tool from **damp** and **wet**.

APPROVAL MARKS



This tool is **CCA** certified (CENELEC Certification Agreement).

TECHNICAL DATA

Electrical safety: **DOUBLE INSULATED**

Voltage	V~	42, 100, 120, 200, 230, for 50/60 Hz	
Power consumption	W	960, 1400, 1600, 1400, 1600	Line/mains voltage cannot be switched over
Temperature	°C	20 – 700, infinitely controlled	
Air flow	l/min.	max. 230	
Air pressure	Pa	3000 (30 mbar) after about 24 h operating time	
Weight	kg	1,3 with 3m cord	
Size	mm	Ø 100 x 330 Handle Ø 56	

Description of the tool

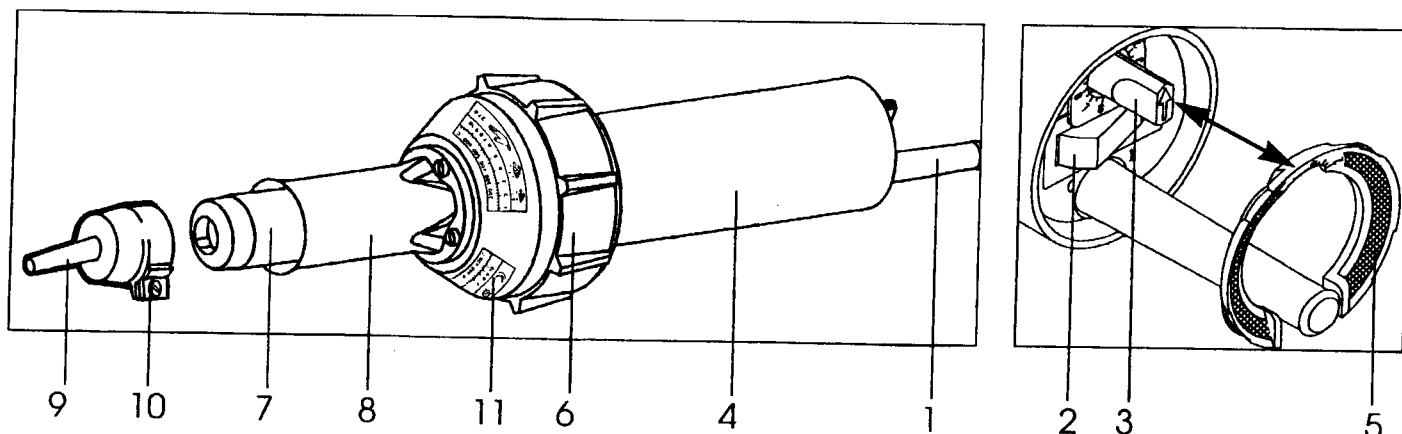

- | | |
|---|-------------------------|
| 1. Power cord | 6. Rubber stand |
| 2. Main switch | 7. Adapter tube |
| 3. Potentiometer for temperature adjustment | 8. Heat protection tube |
| 4. Handle | 9. Nozzle |
| 5. Air filter | 10. Screw on the clamp |
| | 11. Temperature scale |

Readiness for working

- Fit appropriate nozzle as required.
- Connect tool to the line/mains.
- Adjust the hot air temperature by using the **potentiometer (3)**. Standard values see **temperature scale 11**.
- Switch on **main switch (2)** and heat up the tool for approximately 5 minutes.

Operation

- The LEISTER company as well as the Service Centers offer free training courses and advice in all areas of application (see page 1).
- Cool down the tool after use.

Change of nozzles

- Before changing nozzles cool down the tool or use only pliers/wrench.
- Do not touch hot **nozzle (9)** and make sure to place it on a heat resistant surface, because of fire hazard.
- Triac S 1G3 – Push the **nozzle (9)** on the **adapter tube (7)** and secure the nozzle by the **screw on the clamp (10)**.
- Triac S 1G4 – Screw the **nozzle (9)** and secure by wrench.
- Use LEISTER nozzles only.



LEISTER Triac S Hot Air Blower



Order No. 1G3, 1G4



Read operating instructions carefully before use and keep it for further reference.



APPLICATION

- **Welding** of thermoplastic materials as well as single-ply flexible plastics and modified bitumen in the form of boards, tubes, profiles, lining membranes, coated materials, films, foams, tiles, and sheets. The following procedures are possible: overlap welding, welding with rod, with tape, butt welding and melt welding
- **Heating-up** for forming, bending and sealing of thermoplastic semi-finished materials and plastic granules
- **Drying** of water-damp surfaces
- **Shrinking** of heat-shrink sleeves, films, tapes, solder sleeves, pre formed and moulded parts
- **Soldering** of copper pipes, solder joints and metal foils
- **Defrosting** of frozen water pipes
- **Activating/dissolving** of solvent free adhesives and fusion adhesives
- **Igniting** of wood shavings, paper, coal or straw in furnaces

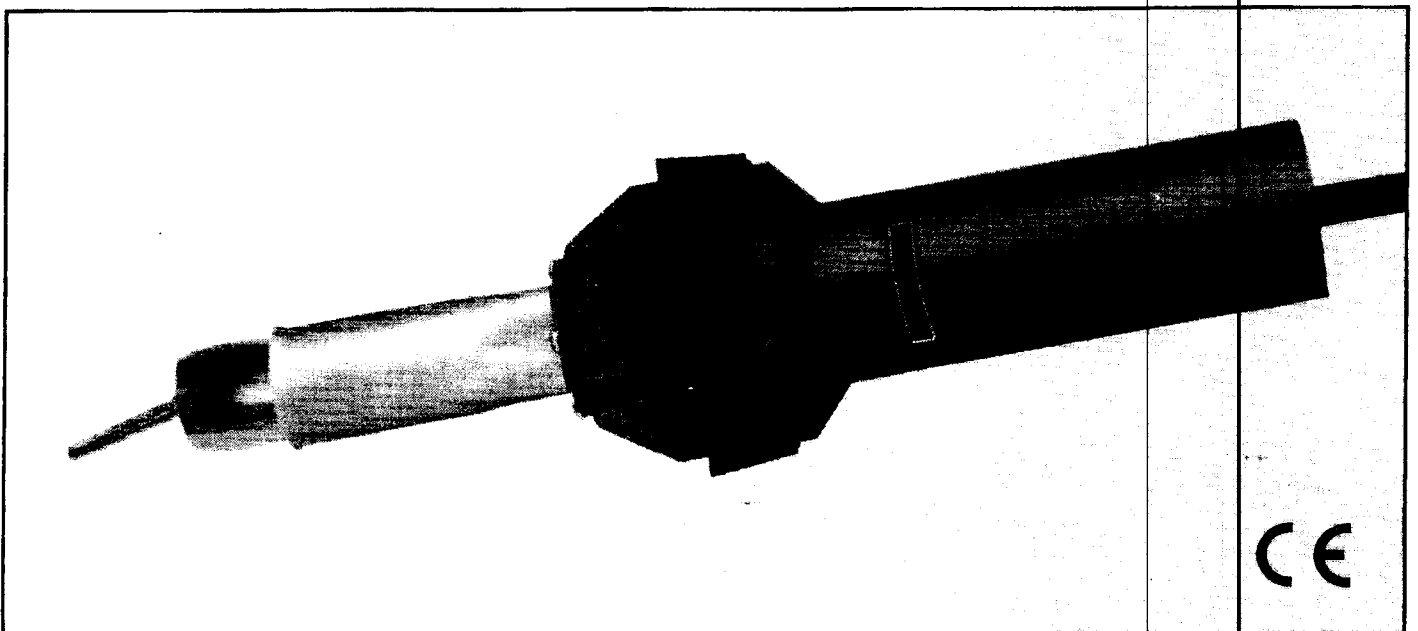



WARNING



Danger to life when opening the tool, as live components and connections are exposed. Unplug the tool before opening it.



Incorrect use of hot air blowers can cause **fire and explosion hazard**, especially near combustible materials and explosive gases.



Do not touch the element housing and nozzle when they are hot as they can cause **burns**. Let the tool cool down. Do not point hot air flow in the direction of people or animals.



CAUTION



The **voltage rating** stated on the tool must correspond to the line/mains voltage.



For personal protection on building sites we strongly recommend the tool be connected to a **GFCI** (Ground Fault Circuit Interrupter) or a **RCCB** (Residual Current Circuit Breaker).



The tool must be operated **with supervision**. Health can reach combustible materials, which are out of sight.



Protect tool from **damp** and **wet**.

APPROVAL MARKS



This tool is **CCA** certified (CENELEC Certification Agreement).

TECHNICAL DATA

Electrical safety: **DOUBLE INSULATED**

Voltage	V~	42, 100, 120, 200, 230, for 50/60 Hz	
Power consumption	W	960, 1400, 1600, 1400, 1600	Line/mains voltage cannot be switched over
Temperature	°C	20 - 700, infinitely controlled	
Air flow	l/min.	max. 230	
Air pressure	Pa	3000 (30 mbar) after about 24 h operating time	
Weight	kg	1,3 with 3m cord	
Size	mm	Ø 100 x 330 Handle Ø 56	

Description of the tool

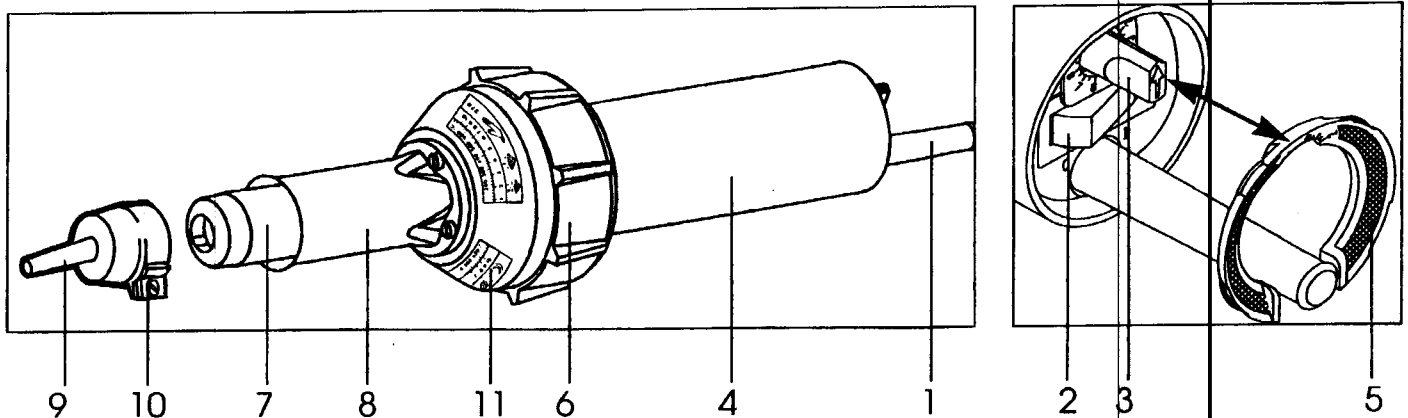

- | | |
|---|-------------------------|
| 1. Power cord | 6. Rubber stand |
| 2. Main switch | 7. Adapter tube |
| 3. Potentiometer for temperature adjustment | 8. Heat protection tube |
| 4. Handle | 9. Nozzle |
| 5. Air filter | 10. Screw on the clamp |
| | 11. Temperature scale |

Readiness for working

- Fit appropriate nozzle as required.
- Connect tool to the line/mains.
- Adjust the hot air temperature by using the **potentiometer (3)**. Standard values see **temperature scale 11**.
- Switch on **main switch (2)** and heat up the tool for approximately 5 minutes.

Operation

- The LEISTER company as well as the Service Centers offer free training courses and advice in all areas of application (see page 1).
- Cool down the tool after use.

Change of nozzles

- Before changing nozzles cool down the tool or use only pliers/wrench.
- Do not touch hot **nozzle (9)** and make sure to place it on a heat resistant surface, because of fire hazard.
- Triac S 1G3 – Push the **nozzle (9)** on the **adapter tube (7)** and secure the nozzle by the **screw on the clamp (10)**.
- Triac S 1G4 – Screw the **nozzle (9)** and secure by wrench.
- Use LEISTER nozzles only.

Car Repairs

- Effortless welding thanks to light weight and smaller handle
- Reproducible welding results thanks to digital temperature display of SET and ACTUAL value
- Adaptor tube with heat protection
- Stepless electronic temperature control, therefore independent of voltage fluctuations and varying ambient temperature (PID control)
- Electronic heating element protection and automatic shut-off of the motor at minimal carbon level
- Multiple replace of carbon brushes possible, therefore suitable for continuous operation

Repair welding and forming of bumpers, air conditioning systems, heating units, spoilers, batteries, lamps, tanks for fuel, oil and water, as well as complete bodywork sections for motor vehicles.

Shrinking and solder shrinking of electronic and electrical interconnect devices and connections.

Hand-welding tools

TRIAC S

The reliable hot air tool

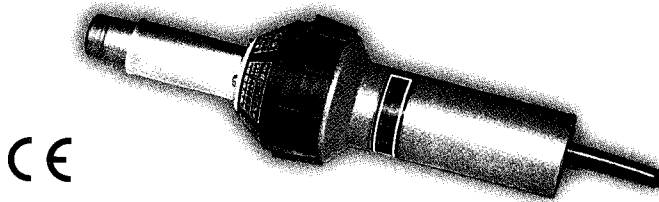

CE

Technical Data

Type	Triaic S	
Voltage	V~	42, 100, 120, 200, 230
Power consumption	W	1000, 1400, 1600, 1400, 1600
Frequency	Hz	50/60
Temperature	°C	20 – 700, steplessly controlled
Air flow	l/min.	max. 230
Pressure stat.	Pa	ca. 3000 (30 mbar), after 24 h operating time
Emission level	L _{pA} (dB)	65
Size	mm	340 × 90, handle ø 56
Weight	kg	1.3 with 3 m cord
Approval mark:		CCA certified

TRIAC PID

The welding tool for quality assurance

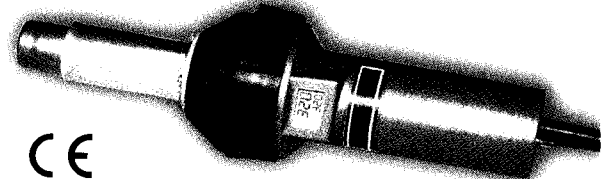

CE

Technical Data

Type	Triaic PID	
Voltage	V~	42, 100, 120, 200, 230
Power consumption	W	1000, 1400, 1600, 1400, 1600
Frequency	Hz	50/60
Temperature	°C	50 – 600, steplessly controlled
Air flow	l/min.	max. 230
Pressure stat.	Pa	ca. 3000 (30 mbar), after 24 h operating time
Emission level	L _{pA} (dB)	65
Size	mm	340 × 90, handle ø 56
Weight	kg	1.4 with 3 m cord
Approval mark:		CCA certified



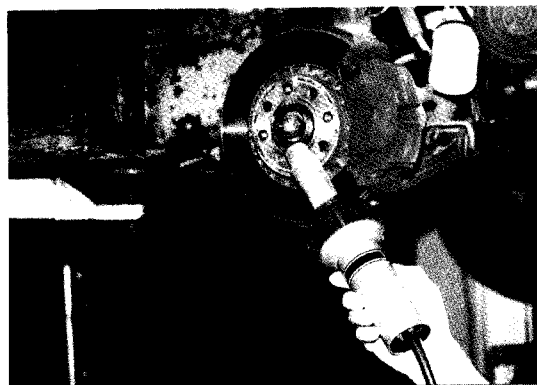

Tight bearings, bolts, bushings, gear wheels, screws and cylinder head gaskets can easily and without damage be loosened or pushed on.



TRIAC S and sieve reflector being used for the splice of an electric cable with a solder sleeve.

HOT JET S

The lightest compact welding tool



Technical Data

Type	Hot Jet S	
Voltage	V~	100, 120, 230
Power consumption	W	460, 460, 460
Frequency	Hz	50/60
Temperature	°C	20 – 600, steplessly controlled
Air flow	l/min.	20 – 80, steplessly adjustable
Pressure stat.	Pa	max. 1600 (16 mbar)
Emission level	L _{PA} (dB)	59
Size	mm	235 × 70, handle ø 40
Weight	g	580 with 3 m cord
Approval mark:		CCA certified

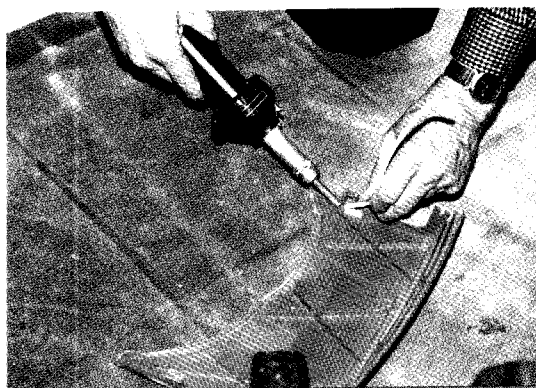

HOT JET S with tubular nozzle Ø 5 mm being used for pendulum welding on an ABS cover.

GHIBLI 

The universal tool

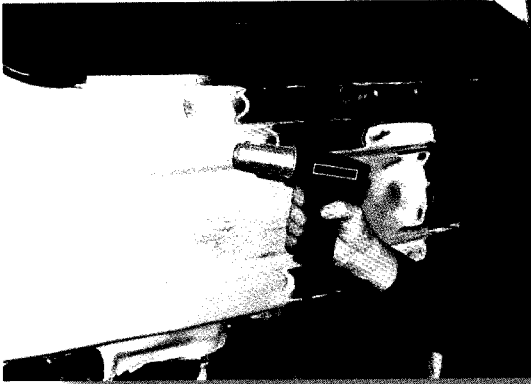

Acceleration of the drying process of varnish, paint and filler with the GHIBLI.

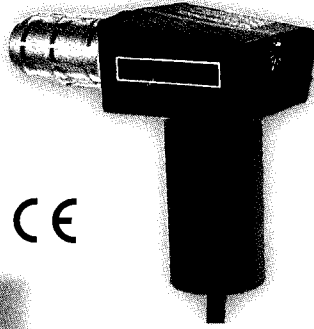

CE

Technical Data

Type	Ghibli	
Voltage	V~	100, 120, 200, 230
Power consumption	W	1500, 1500, 1500, 2000
Frequency	Hz	50 / 60
Temperature	°C	20 – 600, steplessly controlled
Air flow	l/min.	Level 2: 300 Level 3: 350
Pressure stat.	Pa	Level 2: 1500 (15 mbar) Level 3: 2100 (21 mbar)
Emission level	L _{PA} (dB)	67
Size	mm	160 × 195 × 92, handle ø 57
Weight	kg	1.2 with 3 m cord
Approval mark:		CCA certified

Hot air blower**ELECTRON** 

Powerful but still small

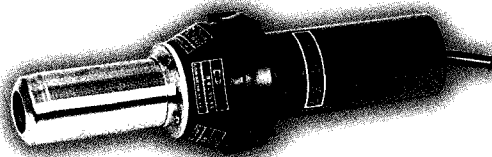

CE

Technical Data

Type	Electron	
Voltage	V~	42, 120, 200, 230
Power consumption	W	1000, 2700, 3000, 2300/3400
Frequency	Hz	50/60
Temperature	°C	20 – 650, steplessly controlled
Air flow	l/min.	max. 500, manual air slide
Pressure stat.	Pa	3000 (30 mbar)
Emission level	L _{PA} (dB)	65
Size	mm	320 × 95, handle ø 64
Weight	kg	1.5 with 3 m cord
Approval mark:		



Fitting of a PVC shear rail to a boat with the ELECTRON.

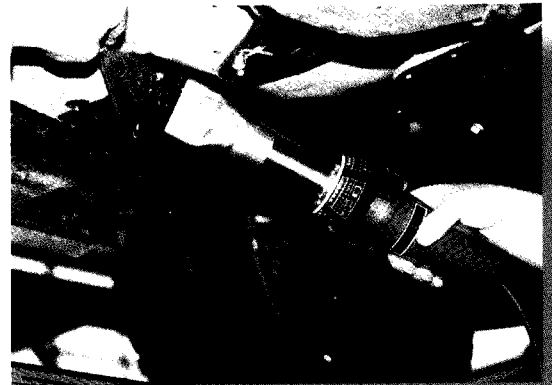

Effortless and smokeless removal of under-floor sealant with the ELECTRON.

Order-Number	Illustration not to scale	
106.975		One-arm pressure roller 40mm with ball bearings (silicon)
106.992		Speed welding nozzle 5.7mm push-fit on tubular nozzle ø 5mm
106.993		Speed welding nozzle 7mm push-fit on tubular nozzle ø 5mm
106.996		Tacking nozzle push-fit on tubular nozzle ø 5mm
106.997		Rotary burr ø 5.5mm
106.998		Wide slot nozzle 20mm push-fit on Ghibli
107.123		Wide slot nozzle ø 20mm, push-fit on Triac PID/Triac S
107.137		Speed welding nozzle for tape 8mm push-fit on tubular nozzle ø 5mm
107.142		Wide slot nozzle 20mm push-fit on Hot Jet S
107.144		Tubular nozzle ø 5mm push-fit on Hot Jet S
100.303		Tubular nozzle ø 5mm push-fit on Triac PID/Triac S
107.154		Tubular nozzle ø 5mm push-fit on Ghibli
107.258		Wide slot nozzle 70 × 10mm push-fit on Electron
107.310		Sieve reflector 35 × 20mm push-fit on Hot Jet S
107.311		Sieve reflector 50 × 35mm push-fit on Hot Jet S
107.324		Sieve reflector 12 × 10mm push-fit on tubular nozzle ø 5mm
107.337		Sieve reflector 50 × 35mm push-fit on Triac PID/Triac S
107.338		Sieve reflector 35 × 20mm push-fit on Triac PID/Triac S
106.654		Welding tape Xenoy, 8 × 2mm, grey
106.649		Welding tape PP 8 × 2mm, self-coloured
107.036		Test bundle profiled welding rod
	Profil A	Endless profiled welding rod 5.7 × 3.7 mm or 7 × 5 mm PP (beige, black), PE-HD (black, white) or ABS (white).
	Profil B	
	Profil A	Endless profiled welding rod 5.7 × 3.7 mm or 7 × 5 mm in PA (black). Endless profiled welding rod 5.7 × 3.7 mm, PC (transparent), ABS-PC-alpha (black), PC thermoplast polyester (Xenoy grey).

Technical data are subject to change without notice



LEISTER Process Technologies
Riedstrasse
CH-6060 Sarnen / Switzerland

Tel. + 41 - 41 662 74 74
Fax + 41 - 41 662 74 16
www.leister.com e-mail leister@leister.com

ISO 9001:2000