

# **DIAMOND**

## **DBR-32WH**

### **REBAR STRAIGHTENER HANDLING INSTRUCTIONS**

**READ THESE INSTRUCTIONS CAREFULLY BEFORE  
ATTEMPTING TO USE REBAR STRAIGHTENER**

**Ignorance of proper operating procedures can lead to accidents.  
If in doubt any procedure, contact your nearest authorized agent.**

**ISHIHARA KIKAI KOGYO CO.,LTD.**

**396-59Ashitaka, Numazu-shi,  
Shizuoka-ken, Japan**

**Phone: (0559)22-8811**

**Fax: (0559)22-2880**

1. Oil should be warm but not hot. Warm up unit if cold.
2. Unplug unit from power source.
3. Remove oil plug and seal washer (packing).

**CAUTION:** Never remove oil-plug when unit is hot or oil spurt out.

4. Check that oil is level with bottom of plug hole (i.e. that pump case is full to the brim). If oil level is too low, top up with 20-weight hydraulic oil with anti-foam and anti-abrasion properties (ISO viscosity grade VG46, e.g. Shell Tellus 46, Mobil oil DTE-25 or Esso Uni Power SQ46).
5. After topping up, extract air from system. Gently tilt the unit and return it to a level position.

Top up again and tilt in the opposite direction. Repeat this process until all air has been extracted.

**CARE:** Rebar straightener cannot function properly if oil contains air bubbles.

6. Replace seal washer (packing) and plug. Extend piston to its full stroke, and remove oil-plug and seal washer. Then repeat the procedure of above 5.
7. Replace oil-plug and seal washer.

**OIL CHANGE**

The hydraulic oil should be changed at least once a year, sooner if it appears dirty.

1. Unplug unit from power source. Remove oil-plug and packing. Turn unit over and drain oil into a suitable receptacle.
2. With drain-hole uppermost, slowly fill the unit with fresh oil. Replace plug and lightly tighten. Connect unit to power source and advance piston two or three times. Unplug unit and remove oil-plug. Top up oil level and replace plug.
3. Finally, follow procedure for oil-level check.

**NOTE:** Dispose of hydraulic oil in accordance with local regulations. Do not pour into sea, a river, a lake or drains.

**BOLT TIGHTNESS**

Once a week, or after every 30 times use, check the tightness of all bolts, especially those securing housing to the cylinder.

**CARBON BRUSHES**

Inspect the two carbon brushes at least once every two months. (Nominal brush life is 200 hours.)

**CARE:** Worn carbon brushes will result in power loss, cause the motor to run hot and irreparably damage the armature's commutator.

1. Disconnect unit.
2. Unscrew both brush caps and pull out carbon brushes.
3. Replace brushes if less than 6mm in length.

**OVERHAUL**

Return the unit to an authorized agent for overhaul at least once every two years, sooner if subject to heavy use.

\*Specifications are subject to change without prior notice.

To pull

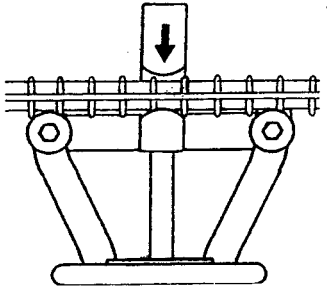

Set the hook in the correct starting position, make sure that the mode control lever is in the "B" position and fit the rebar as illustrated. Pull the trigger switch until the desired angle is attained.

N.B. It is important that the rebar be properly fitted in the hook and against the rollers.

#### Interior angle

Since the piston stroke is limited, interior straightening/bending angle will vary according to rebar diameter and operating mode. Refer to the table below:

Rebar diameter	Straightening capacity		Bending capacity	
	Push	Pull	Push	Pull
13mm (1/2")	Upto 125°	Upto 121°	Upto 94°	Upto 92°
16mm (5/8")	128°	124°	90°	90°
20mm (3/4")	130°	124°	90°	90°
25mm (1")	132°	124°	90°	90°
29mm (1 1/8")	140°	135°	90°	90°
32mm (1 1/4")	144°	138°	90°	90°

( 7 )

#### CLEANING

Clean rebar straightener everyday, preferably immediately after use.

**CAUTION:** Wear gloves to protect hands from metal splinters. Do not use and air-gun : blasting with air can cause metal filings and/or dust to get into eyes and respiratory system.

1. Disconnect unit.
2. Wipe or brush away all dirt and metal filings. Pay particular attention to the lower half of the piston, where dirt is more easily accumulated.
3. Once piston has been retracted, pull trigger switch long enough to partially. Unplug unit. Check piston for accumulated dirt and iron filings that may be jamming the piston.

#### OIL LEVEL CHECK

As rebar straightener is hydraulically operated, the oil-level must be checked at frequent intervals, preferably every day. Failure to maintain the oil at proper level results in a drop in pressure and loss of hydraulic power.

**CAUTION:** Hydraulic oil is highly flammable. Keep away from sparks and naked flame. Do not smoke.

**CAUTION:** Hydraulic oil may cause inflammation of the eyes and skin. If ingested, it will cause diarrhoea and vomiting. In case of eye contact, rinse in clean water for at least 15 minutes and consult a physician. In case of skin contact, wash thoroughly with soap and water.

In case of ingestion, consult a physician immediately. Do not deliberately induce vomiting.

( 8 )

5. Before plugging in, make sure that the switch lock is OFF.

**CAUTION:** If switch lock is ON, rebar straightener will start as soon as it is plugged in. To disengage lock, pull trigger switch, lock button will pop out.

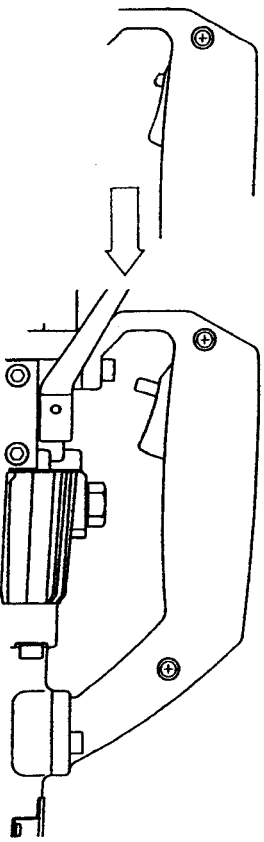

### **WARM UP**

In cold weather, warm up unit for 30~60 seconds so that the hydraulic oil reaches the proper viscosity. Pull trigger switch to extend piston and release when it has reached its full stroke. Repeat 3~5 times.

### **POINTS OF ATTENTION**

1. Do not cover air vents.

**CARE :** If vents are covered, motor will overheat and may burn out.

2. If hydraulic oil exceeds 70°C (158°F) in temperature, power will drop.

Allow unit to cool before resuming operation. (Be particularly careful in summer, when the aluminum pumpcase heats up quicker.)

2. If a drop in power is observed and motor is unusually hot, check carbon brushes.

(5)

### **OPERATION**

The DBR-32WH is primarily intended to straighten deformed rebars. It can, of course, also be used to bend a straight rebar.

To enable the unit to be used in confined spaces, there are two operating modes: push and pull.

The mode is selected by moving the mode control lever to the appropriate position. "A" for push (piston advances) and "B" for pull (piston retracts). In either mode, simply press the switch to move the piston.

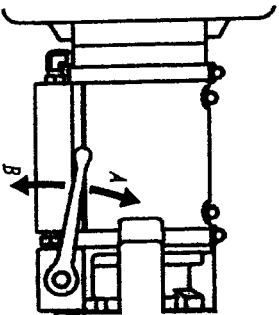

N.B. The movement of the piston is limited by a safety valve. To prevent overheating, release the trigger switch when the piston has reached its travel limit.

**To push**

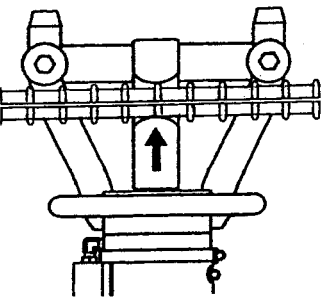

Advance or retract the piston so that the hook is in a suitable starting position. Set the mode control lever to "A" and fit the rebar as shown at left. Pull the trigger switch until the rebar is at the desired angle.

(6)

**STORE CAREFULLY**

When not in use, store rebar straightener and accessories in a dry place where they cannot be accessed by unauthorized persons.

**PARTS AND SPECIFICATIONS**

1. Handle
2. Switch
3. Mode control lever
4. Oil plug
5. Front handle
6. Hook
7. Roller
8. Housing
9. Motor

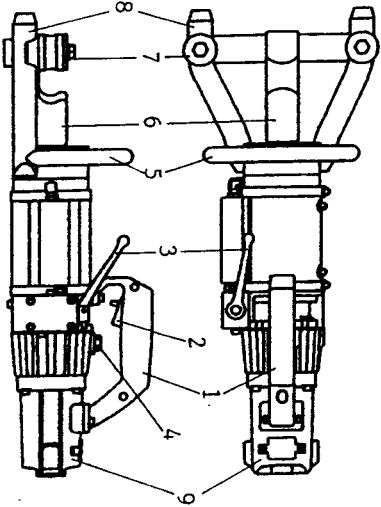

Max. rebar dia.	32mm $\phi$			
Straightening	Max yield point 345N/mm <sup>2</sup> Max yield point 295N/mm <sup>2</sup>			
Rebar diameter	Straightening capacity		Bending capacity	
	Push	Pull	Push	Pull
13mm	upto 125°	upto 121°	upto 94°	upto 92°
16mm	128°	124°	90°	90°
20mm	130°	126°	90°	90°
25mm	132°	124°	90°	90°
29mm	140°	135°	90°	90°
32mm	144°	138°	90°	90°
Max pressure	11 tons	8.5 tons	11 tons	8.5 tons
Output	1.5 HP			
Weight	22.5 Kg			
Dimensions	660x270x200mm (LxWxH)			

( 3 )

**OPERATING INSTRUCTIONS**

**CAUTION:** Indicates hazard that could result in minor personal injury and/or product damage.

**CARE** : Indicates hazard that will result in products damage.

**Pre-use check**

1. Check oil level. (See oil-check page 9.)

2. Check that the power source is appropriate to the rebar straightener.

**CARE** : If voltage is too high, the motor will burn out, If voltage is low, insufficient power will be generated.

Never use DC current.

3. Check that power supply is properly earthed.

**CAUTION:** Failure to earth power supply may result in electric shock to operator.

4. Check that cord is undamaged and that plug is not loose.

**CAUTION:** Cut or abraded covering could result in a short and electric shock to operator.

If an extension cable is to be used, make sure that it is undamaged and that it is the proper thickness for the length. See the table below.

Cable length	100/115V		230V
	Cable size (AWG)	Nominal diameter	
Upto 10m (33 ft)	16	1.0mm <sup>2</sup>	1.25mm <sup>2</sup> 1.5mm <sup>2</sup>
Upto 15m (50 ft)	14		
Upto 30m (100 ft)	10		

( 4 )

**GENERAL SAFETY PRECAUTIONS**

Application: Use DBR-32WH on concrete re-inforcing bars only. (See specifications on page 3.)

**RESTRICT USE TO DESIGNATE MATERIALS**

There is always a chance that the end of material may break and shoot out, especially if the material is harder than those specified. Exceeding designated material specifications greatly increase this risk and will also damage the tool. Do not attempt to use the tool for rebars harder, thicker or thinner than those specified (see page 4).

**USE EYE PROTECTION**

Wear safety goggles, safety glasses with side shields or a face shield when using rebar straightener.

**KEEP HANDS AWAY**

Do not touch rebar, housing, hook, rollers and piston while rebar straightener is being operated.

**GUARD AGAINST ELECTRIC SHOCK**

To avoid possible electric shock, do not handle DBR-32WH with wet hands or use it in the rain or damp places. Be aware of all power lines, electric circuit and other hazards that may be contacted, especially those that are below the surface or otherwise hidden from view.

**UNPLUG TOOL**

Disconnect tool from outlet when not in use and before cleaning, adjusting or servicing. Do not disconnect plug from outlet by pulling the cord. Always check that the switch lock is OFF before plugging in.

( 1 )

**BEWARE OF ENVIRONMENT**

Do not use rebar straightener in the presence of flammable materials (e.g. paint, thinner, petroleum products, adhesives). Do not use rebar straightener in a possibly explosive environment (e.g. an area containing fumes, gas or dust) or poorly ventilated areas.

**KEEP WORK AREA TIDY AND WELL LIT**

Make sure that work area is properly lighted and clear of obstructions. Operator should at all times have an unobstructed view of rebar straightener, rebar and surrounding area.

**WEAR PROPER APPAREL**

Do not wear loose cloths, dangling objects or jewellery. Restrain long hair. The use of safety-helmet and rubber soled boots is recommended. If safety gloves are worn, be especially careful that glove does not get caught in moving parts.

**KEEP VISITORS AWAY**

Keep all visitors at a safety distance from the work area for their own protection and to prevent distraction of the operator.

**MAINTAIN REBAR STRAIGHTENER WITH CARE**

Inspect rebar straightener before each application. Faulty or loose bending hook could result in personal injury. Keep handle dry, clean and free from oil and/or grease. Keep housing and piston free of dirt and iron filings. Check that no screws or bolts are loose or missing. Follow instructions for maintenance. Inspect switch, cord, plug and any extension cable at regular intervals.

( 2 )