

SCANNED
No. 725

Ogura ELECTRO-HYDRAULIC REBAR STRAIGHTENER Model: HBB-25 HBB-525 HBB-32 HBB-32HPW ELECTRO-HYDRAULIC REBAR BENDER Model: HBB-19180 06165004

Instruction Manual

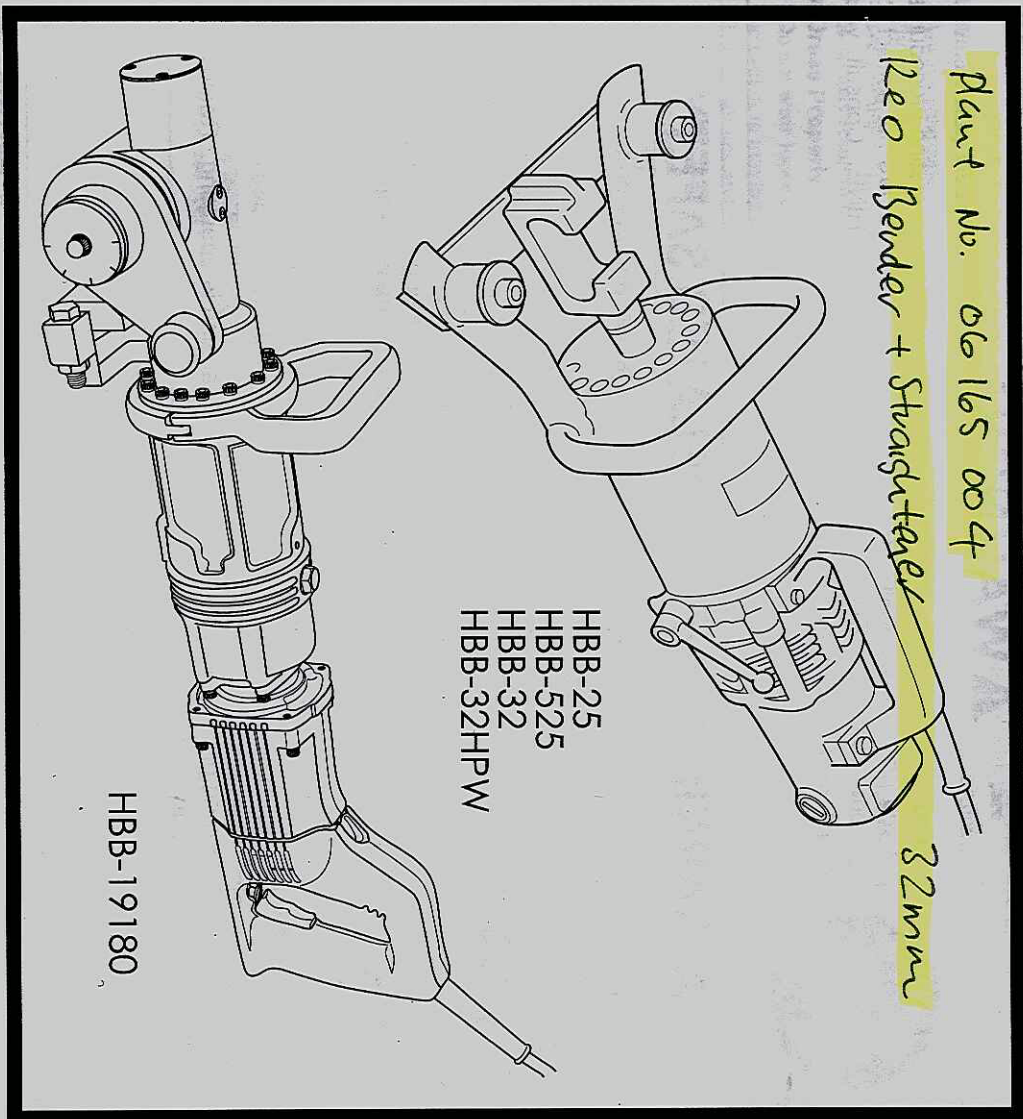

TABLE OF CONTENTS

IMPORTANT SAFETY INSTRUCTIONS	3
SPECIFICATIONS	5
PARTS NAMES (HBB-25/HBB-525/HBB-32/HBB-32HPW).....	6
OPERATING PROCEDURE (HBB-25/HBB-525/HBB-32/HBB-32HPW).....	7
SPECIAL INSTRUCTIONS FOR BENDING AND STRAIGHTENING REBAR.....	9
PARTS NAMES (HBB-19180)	10
OPERATING PROCEDURE (HBB-19180)	11
ADDING OIL	13

Meaning of "caution" and "warning" indications

Caution: Indicates a potentially hazardous situation which, if not avoided, may result in minor or moderate injury. This is also used to alert against unsafe practices associated with events that could lead to personal injury.

Warning: Indicates a potentially hazardous situation which, if not avoided, will result in death or serious injury.



***** Ogura & Co., Ltd. shall not be responsible for any incidental damages or personal injuries resulting from negligence of Warnings and Safety Instructions contained in the Instruction Manual.**

▲ WARNING



Read, understand and follow all safety instructions and operating procedures. If you do not understand the instructions, or if conditions are not correct for proper operation, DO NOT OPERATE THE MACHINE. Consult your supervisor or other responsible person.

▲ WARNING LABELS RELATED SAFETY

	Flying debris and loud noise hazards. Wear ear and eye protection.
	Hazardous voltage. Remove battery before working on this equipment. Failure to observe this instruction will result in death or serious injury.
	Moving parts. Keep hands clear while machine is operating. Remove battery before servicing.

SAVE THESE INSTRUCTIONS

IMPORTANT SAFETY INSTRUCTIONS

WARNING

1. **Before use, read this Instruction Manual thoroughly.**
2. **Keep Work Area Clean.**
 - Cluttered areas and benches invite injuries.
3. **Keep the work area well lighted.**
 - Working where there is insufficient light may cause an accident.
4. **Keep Children Away.**
 - Do not allow children or unauthorised personnel to handle tool.
5. **Store Idle Tools.**
 - All visitors should be kept away from work area.
 - When not in use, tools should be stored in a dry and secure place - out of reach of children.
6. **Do Not Force Tool.**
 - It will do the job better and safer at the rate for which it was intended.
 - Do not force tool to work beyond its ability. Excessive load will cause seizure of the motor, overheating, smoke and fire.
7. **Use Right Tool.**
 - Do not force small tool or attachment to do the job of a heavy-duty tool.
8. **Wear Safety Glasses and Protective Clothing.**
 - Do not use tool for purpose not intended.
 - Always wear safety glasses, safety footwear, safety gloves, and any other mandated or necessary protective clothing while using this equipment. Failure to do so may result in injury.
9. **Dress Properly.**
 - Do not wear loose clothing or jewellery as they can be caught in moving parts.
 - Rubber gloves and non-skid footwear are recommended when working outdoors.
 - Wear protective hair covering to contain long hair.
10. **Hold Tool Securely.**
 - A tool that is not held securely may injure you.
 - Use clamps or a vice to hold the work. This frees both hands to properly hold, control, and operate the tool. Failure to properly secure the work may result in injury.
11. **Disconnect the tools power supply, by removing the Battery and engaging the Trigger Switch Lock, whenever one of the following situations occur.**
 - The tool is not in use or is being serviced.
 - Any parts, such as a blade, are being replaced.
 - There is a recognised hazard. Failure to do so may result in unexpected operation and damage or injury.
12. **Avoid Unexpected Operation.**
 - Do not carry the tool by the Trigger Switch as this may cause unexpected operation and damage or injury.
13. **Do Not Abuse Power Cord.**
 - Keep cord away from heat, oil and sharp edges.
 - Place cord so that it will not be stepped on, tripped over, or otherwise subjected to damage or stress.
 - If the tool is dropped or struck check carefully that body is not damaged, cracked, or deformed.
14. **Do Not Overreach.**
 - Keep proper footing and balance at all times.
15. **Maintain Tools Carefully.**
 - Keep tools sharp and clean for better and safer performance.
 - Follow instructions for lubricating and changing accessories.
 - Inspect battery charger power cord periodically and, if damaged, have them repaired by authorized service facility.
 - Keep handles dry, clean, and free from oil and grease.
16. **Remove Keys and Wrenches.**
 - Form habit of checking to see that keys and wrenches are removed from tool before starting operation.
17. **Stay Alert When Using Electric Tools.**
 - Consider safety of others.
 - Operate tool with care.
 - Watch what you are doing.
 - Use common sense.
 - Do not operate tool when you are tired.
18. **Check For Damaged Parts.**
 - Before using the tool, carefully check all parts for damage, including guards, to ensure that they will operate properly and perform their intended function.
 - Check for any misalignment or binding of moving parts; damaged or broken parts and mountings; and any other conditions that may affect its operation.
 - A guard or other part that is damaged should be properly repaired or replaced by an authorized service centre unless otherwise indicated in this instruction manual.
 - Do not use tool if switch does not turn it on and off. Have damaged or defective switch replaced by an authorised service centre.
19. **Service at Factory Authorized Repair Centre Only.**
 - Service this electric appliance in accordance with the relevant safety regulations.
 - Repairs to electric appliances should only be done by a qualified person. Repairs by others may endanger the user.
 - Contact your dealer to arrange servicing.
20. **Only Use the Specified Accessories or Attachment.**
 - Use only the accessories or attachment described in this Instruction Manual and the Ogura catalog. Use of any other accessories or attachments may result in an accident or injury.

SAFETY INSTRUCTIONS FOR ELECTRO HYDRAULIC REBAR BENDER

▲WARNING

- Models which are not double insulated should be grounded when in use to protect the operator from electric shock.
- See Specifications in page 5 for the bending capacity and page 9 for the required dimension of rebar. Do not bend harder material or in dimension beyond its ability.
- Before bending, rebar must rest fully within bending area. Failure to do so cause the rebar may fly off during bending.
- Always consider safety of surroundings. Keep face or fingers away from bending area during operation. Failure to do so may cause serious injury to operator and others.
- Replace the worn, deformed, damaged or cracked parts immediately. Keep using these parts may cause damage to tool, resulting in serious accident. Replace them with Ogura genuine parts.
- Tool should be connected only to power supply of the same voltage as indicated on the name label.
- If extension cord must be used, the wire size is at least as large as one specified below. (Use only 3-wire extension cord that has 3-prong grounding type plugs and 3-pole receptacles that accept the tool's plug). Replace or repair the damaged cord.

USA cord size	Maximum cord length
(Nominal cross sectional area of conductor)	15 m
1,25 mm ²	30 m
2,00 mm ²	
- Confirm the bolts are tighten properly before bending and retighten if necessary.

▲CAUTION

- Avoid Electric Shock**
 - Power source with a breaker is recommended to avoid the electric shock.
- Follow Local Noise Level Regulations**
 - Operate tools within a soundproofed enclosure if necessary.
- Check Before Operation**
 - Do not use the tool for a purpose it was not intended for. Replace parts when and as directed in this instruction manual.
 - Confirm that all bolts and screws are tightened properly before operation begins.
- Operate Tool With Proper Voltage**
 - The tool should be connected only to a power supply of the same voltage as indicated on the product label. If connected to a higher voltage the motor will over speed and eventually burn out. If connected to a lower voltage the motor will be damaged and eventually break up.
- Pay Attention When Operating**
 - Keep proper footing and balance at all times.
 - Stop operation immediately when the tool is out of order or makes abnormal sound during use.
 - During tool operation, keep hands and face away from the blades, all moving parts and the scrap ejection section.
 - Cutting ability falls as the tool temperature rises. If tool temperature reaches 70°C or higher, cutting operation should be stopped for 30 to 60 minutes to allow the tool to cool.
 - Carbon brushes should be replaced every 200 hours or when the length of the brush is reduced to 6 mm.
- Protect Tool**
 - Handle tool carefully. If it is dropped or struck it could be damaged.
 - The motor air vents should be open and unobstructed as they provide cooling for the motor. Keep the air vents clear of dust, dirt and debris or the motor will over heat and be damaged.
- Maintain Tool**
 - Keep tool clean to stay in best condition. Always wipe off dirt and oil from the motor, switch, and handles.
 - Use only Ogura genuine parts for replacement.
 - Check the tool regularly so that it can be used safely and effectively.
 - Stop operation immediately and contact your dealer if the tool is making abnormal sounds or is out of order in any way. Do not disassemble the tool as the internal components are sensitive to damage from dust, dirt, contamination of the hydraulic fluid or improper handling.
 - This is a hydraulic tool powered by electricity. When the temperature is low, the oil will thicken and tool may not work properly. Idle tool for a few minutes before use.

SPECIFICATIONS

Bending Capacity (Diameter)	HBB-525	HBB-25	HBB-32	HBB-32HPW
	Intermediate Grade (490N/mm ²) 49 kgf/mm ² 70,000 psi	up to 25 mm	up to 32 mm	up to 32 mm
Hard Grade (560N/mm ²) 57 kgf/mm ² 80,000 psi	up to 22 mm	up to 29 mm	up to 29 mm	up to 29 mm
High Strength Grade (620N/mm ²) 63 kgf/mm ² 90,000 psi	up to 22 mm	up to 29 mm	up to 32 mm	
Bending Angle (Degree)	0 ~ 90			
Bending Speed (Second)	90 degrees (25 mm) Push Bending - 7 Pull Bending - 6	90 degrees (25 mm) Push Bending - 8.5 Pull Bending - 8	90 degrees (32 mm) Push Bending - 14.5 Pull Bending - 15.5	90 degrees (32 mm) Push Bending - 16 Pull Bending - 15
	1,330 W □ Single - phase, AC 115/230 V, 50/60 Hz	700 W Single - phase, AC 115/230 V, 50/60 Hz		1,330 W □ Single - phase, AC 115/230 V, 50/60 Hz
Dimensions (L×W×H mm)	486×194×226	481×190×207	590×290×210	670×302×219
Weight	15.2 kg	14 kg	22.6 kg	25.4 kg
		Wooden box Hydraulic oil #46 Double end spanner (17 · 19 mm) Clamping Nut Spanner Spanner (24 mm)		
Standard Equipment	Hex wrenches (4 · 5 · 6 mm)		Hex wrenches (3 · 4 · 5 · 6 mm)	
	Bending roller (46 mm, 52 mm)		Bending roller (60 mm)	Bending roller (80 mm)
	Roller washer			

● Specifications and design may be subject to change without prior notice.

PARTS NAMES HBB-25/HBB-525 HBB-32/HBB-32HPW

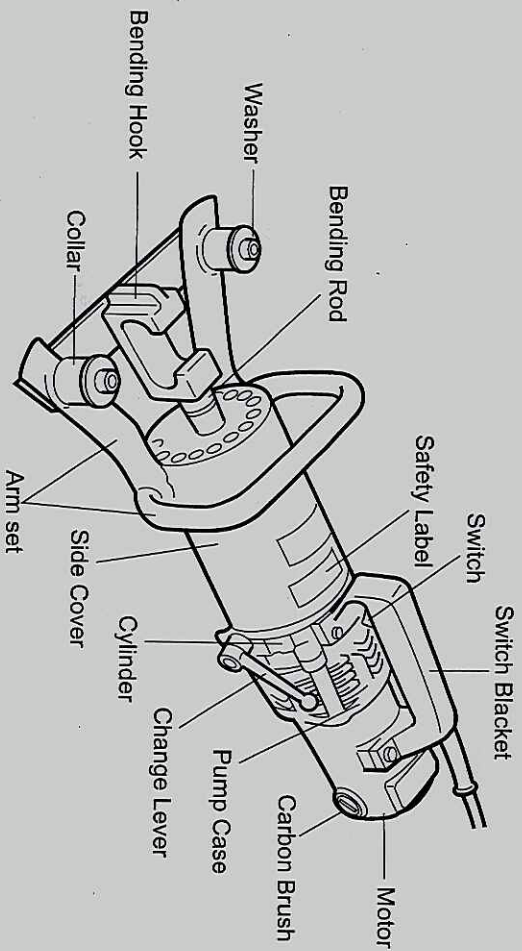

■ Angle for Bending

	Bending Angle			
	with Roller		without Roller	
HBB-25	HBB-32	HBB-32	HBB-25	HBB-32
HBB-525	HPW	HBB-525	HPW	
φ13	85°	95°	82°	-
φ16	80°	90°	78°	-
φ19	75°	85°	69°	-
φ22	-	80°	65°	90°
φ25	-	-	65°	85°
φ29	-	-	-	90°
φ32	-	-	-	85°

■ With Roller

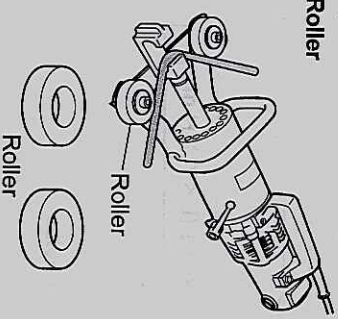

■ Bending angle

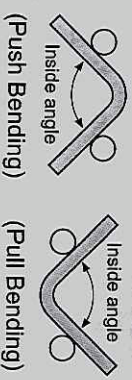

■ Bending Hook C (Option)



■ Angle for Modification

	Inside Angle of Existing Bends		
	Standard Hook	HBB-32	HBB-32 HPW
HBB-25			
HBB-525			
φ13	153°	124°	125°
φ16	158°	126°	130°
φ19	163°	133°	135°
φ22	168°	136°	137°
φ25	172°	142°	138°
φ29	-	147°	145°
φ32	-	149°	147°

■ Carbon Brush Size

Model	Part Number	Size
HBB-25	6071070	12.5 (W) × 6.5 (T) × 17 (L) mm
HBB-32	6071070	12.5 (W) × 6.5 (T) × 17 (L) mm
HBB-32HPW	6415720	13.5 (W) × 6.5 (T) × 18 (L) mm
HBB-525	6415720	13.5 (W) × 6.5 (T) × 18 (L) mm

*For modification of 90° inside angle

OPERATING PROCEDURE

Push Bending

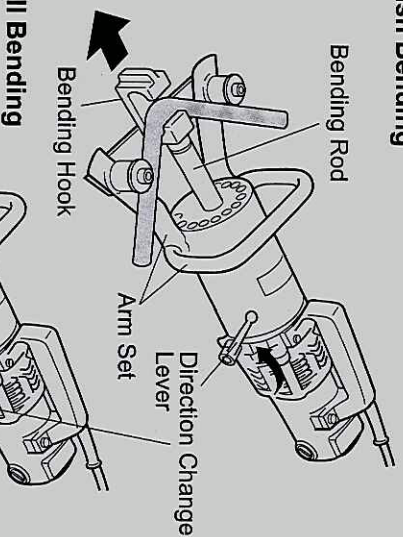

1. Confirm that the power supply is 115V/230V single phase. Insert the plug into the power outlet and connect the plug to ground. If your power outlet has no earth, first install a ground adapter on the tool side, before inserting the plug.

2-1. Push Bending

With the Bending Rod fully retracted, position the reinforcing steel bar to be bent in the Hook at the tip of the Bending Rod. Turn the Direction Change Lever to the "rod extend" position and operate the Switch for bending.

2-2. Pull Bending

With the Bending Rod fully extended, position the reinforcing steel bar to be bent in the Hook at the tip of the Bending Rod. Turn the Direction Change Lever to the "rod retract" position and operate the Switch for bending.

Note: Do not operate the tool when the Direction Change Lever is between the two operating positions.

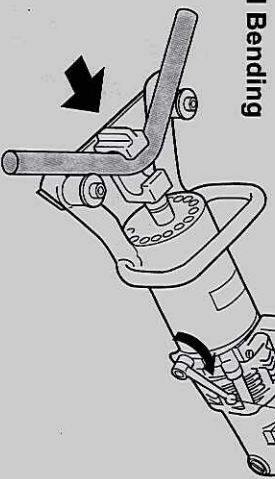

Note: After the bending operation is completed it will be necessary to reverse the direction of movement of the Bending Rod so that the reinforcing steel bar can be removed from the tool.

*Rotating function of the Bending Arm Set

The Bending Arm Set with Handle can be rotated freely through 360 degrees to achieve the best position for the operating environment.

2-3. To modify bends in reinforcing steel bar

To straighten or change the bend angle, place the Bending Hook over the top of the bends of the reinforcing steel bar to be modified and operate as 2. and 3. above. When the inside angle of the bent to be modified is less than the minimum degrees for standard Hook A as in the Table (Page 8), the optional Bending Hook C should be used up to 90 degrees of minimum inside angle.

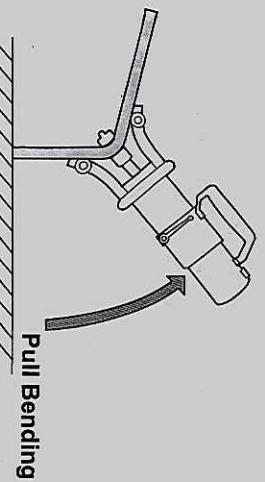
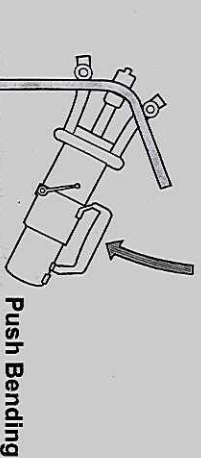
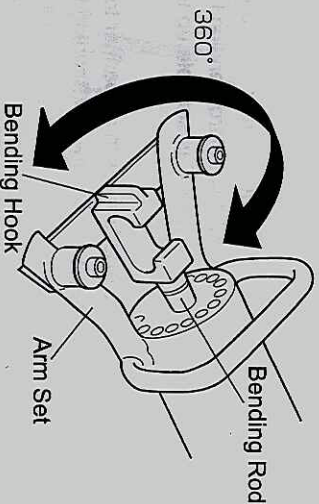

▲ CAUTION

Make sure to place the Bending Hook over the top of the bends when modifying. To modify bends with the Bending Hook to be placed out of the top may cause the excessive force to the Bending Rod and the Bending Hook, resulting in the damage or the breakage of the Bending Rod and the Bending Hook.

Operating Procedure

▲ CAUTION

To avoid damaging or breaking the Bending Hook

- The Bending Hook is screwed onto the Bending Rod and together they are free to rotate. To prevent damage to the Hook and Rod during operation ensure that the Bending Hook is screwed firmly onto the Bending Rod. See "Instructions for changing the Bending Hook" on this page.

- When bending reinforcing steel bar that is fixed in position the tool, not being fixed, will move. Ensure that there is enough space to allow the tool to move. If there is insufficient space and the tool contacts the floor, wall, ceiling, etc., the excessive forces generated may damage or break the Bending Rod. See "SPECIAL INSTRUCTION FOR BENDING AND STRAIGHTENING REBAR" on page 9.

Instructions for changing the Bending Hook

The Bending Hook, which is screwed onto the Bending Rod, which is screwed onto the Bending Hook, can be replaced with the optional Bending Hook C. This is done when the inside angle of a bend to be modified is too acute for the standard Bending Hook. The optional Bending Hook C is suitable up to 90 degrees.

1. Hold the Bending Rod firmly with a spanner to prevent it from turning and unscrew the Bending Hook in a counter clockwise direction, to remove it from the Rod. If it is tight it may be necessary to use a spanner or bar through the hook to loosen it first.
2. Screw the optional Bending Hook C onto the Bending Rod by hand in a clockwise direction until it will go no further. Using a spanner or bar through the hook give it a final tighten to ensure that it is fully screwed onto the Rod.
3. With a spanner rotate the Bending Rod so that the opening in the Bending Hook is facing up.

The Bending Hook and Bending Rod can be rotated together. The Bending Arm Set and the Bending Rod with Bending Hook can be turned to the best position for the bending situation.

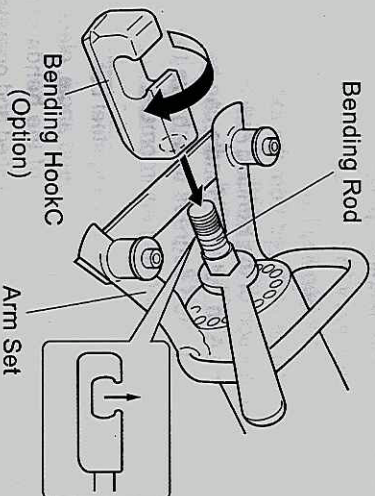

SPECIAL INSTRUCTIONS FOR BENDING AND STRAIGHTENING REBAR

Bending

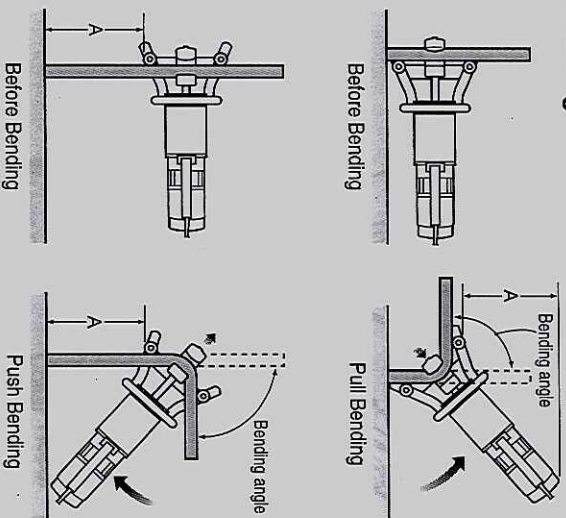

To bend reinforcing steel bar that has one end fixed to the floor, wall, ceiling, etc.

• When bending reinforcing steel bar close to the floor, wall, ceiling, etc., the "Pull Bending" method should be used. When "Pull Bending", the tool will move in the direction of the arrow and away from the surface, as shown in the drawing on the left. Before starting, ensure that there is sufficient space for the tool to move (see "A" in the drawing on the left and its dimension in the following table).

• When there is not enough space for "Pull Bending", the "Push Bending" method should be used. When "Push Bending", the tool will move in the direction of the arrow and towards the floor, wall, or ceiling etc., as shown in the drawing on the left. Before starting, ensure that there is sufficient space for the tool to move (see "A" in the drawing on the left and its dimension in the following table).

	A (Bending angle 45°)	A (Bending angle 90°)
HBB-25/HBB-525	160 mm	310 mm
HBB-32	170 mm	360 mm
HBB-32HPW	180 mm	385 mm

Modifying Existing Bends Standard Hook

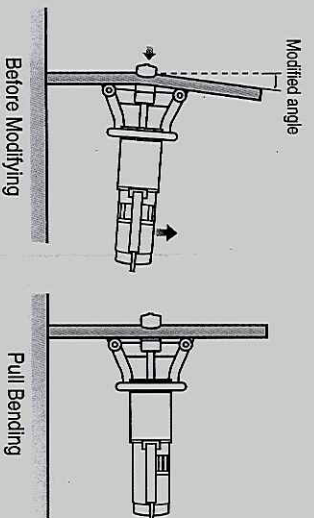

The tool will move parallel to the floor, wall, ceiling, etc., as shown in the drawing on the left. The max achievable modified angle is shown in the following table.

	Modified angle
HBB-25/HBB-525	8° (D25)
HBB-32	31° (D32)
HBB-32HPW	33° (D32)

Note: Up to 90 degrees of modification is possible by using the Bending Hook C, but it should be noted that the steel bar can fracture during the bending process depending on the material of the bar. When modifying the bend the tool will move in the direction of the arrow as shown in the drawing on the left. Before Starting, ensure that there is sufficient space for the tool to move when modifying the bend (see "B" in the drawing on the left and its dimension in the following table).

	B (Modified angle 90°)
HBB-25/HBB-525	503 mm
HBB-32	670 mm
HBB-32HPW	710 mm

⚠ WARNING

Operating the tool where there is insufficient space (see table) will result in forces contact between the tool and obstacle causing damage to the tool and Bending Rod.

⚠ WARNING

Do not bend material that is cracked or chipped as this may cause an accident or injury to the operator.

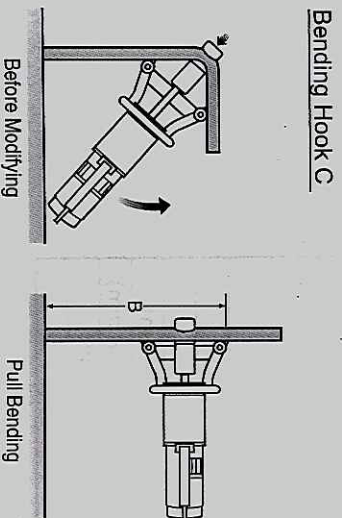

PARTS NAME HBB-19180

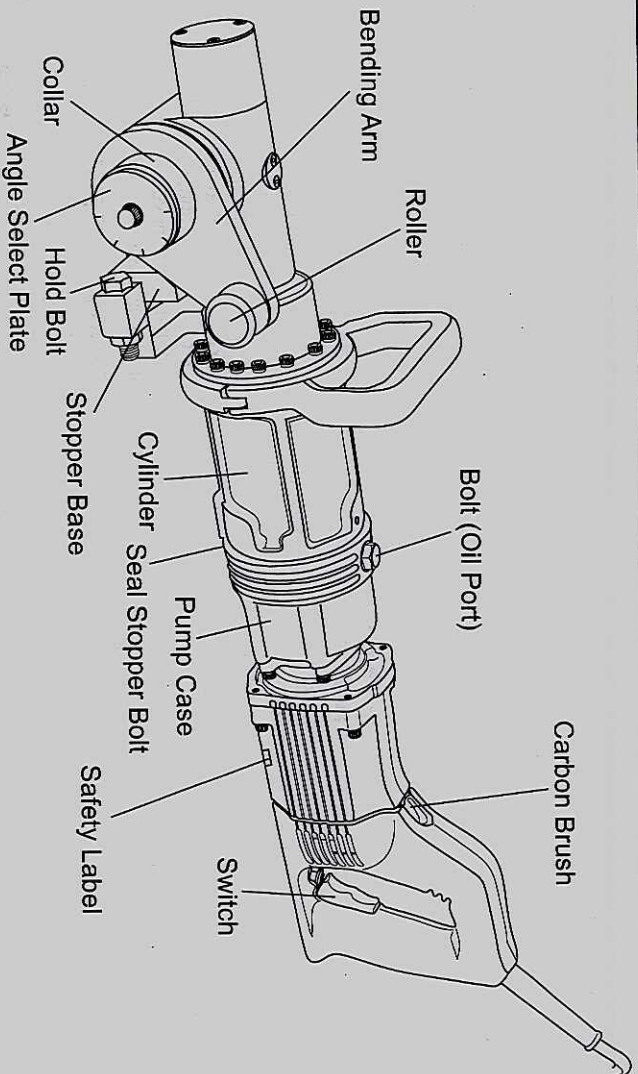

Bending Capacity (Diameter)	HBB-19180
Intermediate Grade (490N/mm ²) 49 kgf/mm ² 70,000 psi	up to 19 mm
Hard Grade (560N/mm ²) 57 kgf/mm ² 80,000 psi	up to 19 mm
High Strength Grade (620N/mm ²) 63 kgf/mm ² 90,000 psi	up to 19 mm
Bending Angle (Degree)	0~180
Bending Speed (Second)	180 degrees (19 mm) Push Bending - 15 sec.
Motor	1,050W  Single - phase, AC 115/230V, 50/60 Hz
Dimensions	730 X 165 X 195 mm
Weight	13 kg
Standard Equipment	Wooden box
	Hydraulic oil #46
	Double end spanner (17・19 mm)
	Hex wrenches (2.5・3・4・5・6・8 mm)
	Bending roller (32 mm, 52 mm)
	Collar (52 mm, 60 mm)

■ Carbon Brush Size

Model	Part Number	Size
HBB-19180	6400580	11 (W) X 7 (T) X 17 (L) mm

OPERATING PROCEDURE



WARNING

Failure to obey the following instructions may damage the tool and cause serious injury to the operator.

- Do not bend any material that is not reinforcing bar.
- Do not bend rebar that is more than 19 mm diameter.
- Do not bend rebar which has a hardness of more than 620N/mm² (63kgf/mm²), 9,000 psi.

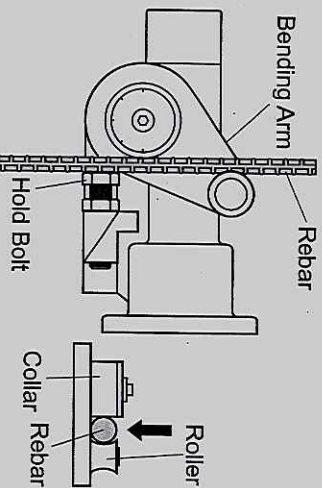

1. Confirm that the tool rating (115V or 230V single phase) is the same as the power supply and plug into the power outlet.
2. Position the rebar to be bent so that it is fully between the Roller and the Collar on the Bending Arm as shown in the figure on the left.



WARNING

If the rebar is not positioned fully between the Roller and the Collar, the rebar will be ejected violently from the Bending Arm, during bending operation, and may cause serious personal injury.

3. Adjust the Hold Bolt so it is just touching the rebar and then tighten the Hold Nut to lock it in position. The head of the Hold Bolt supports the rebar during bending.
4. Pull the Trigger Switch on the Motor to start the bending operation. The Bending Arm will rotate. Release the Trigger Switch when the rebar is bent to the required angle between 0 degrees and 90 degrees. The Bending Arm returns to its starting position automatically.

Operating Procedure

HBB-19180

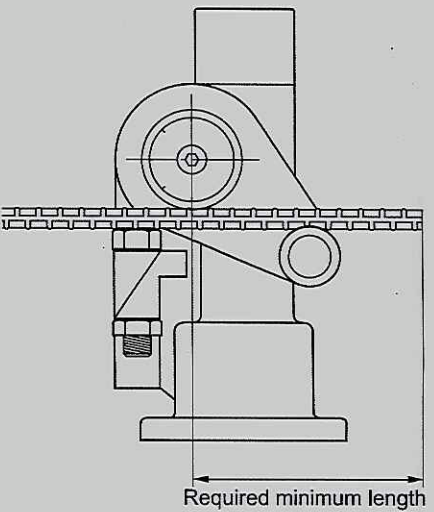

	Collar		90° bending	135° bending	180° bending
	Shaft ϕ 45	Roller (ϕ 52)			
D10	ϕ 52	(ϕ 52)	132 mm	154 mm	175 mm
	ϕ 60	(ϕ 52)	134 mm	158 mm	183 mm
D13	ϕ 52	(ϕ 52)	136 mm	164 mm	191 mm
	ϕ 60	(ϕ 52)	133 mm	159 mm	184 mm
D16	ϕ 52	(ϕ 52)	135 mm	164 mm	192 mm
	ϕ 60	(ϕ 52)	132 mm	159 mm	186 mm
D19	ϕ 60	(ϕ 52)	134 mm	164 mm	193 mm
	ϕ 60	(ϕ 32)	144 mm	175 mm	206 mm

⚠ WARNING

Rebar that is shorter than the minimum length stated in the above table will be ejected from the Bending Roller and may cause serious personal injury.

ADDING OIL

1. Set the change lever on the side of the machine to the arm set position(forward).
2. Pull the switch gradually to move the bending rod almost to the end of its stroke.
3. To supply oil, rotate the cylinder with a motor so that the change lever is located in the upper position of the machine and put the oil port upwards.
4. Loosen the bolt of the oil port on the side of the change lever, remove it, then supply oil.
5. Tighten the bolt of the oil port once, rotate the cylinder and return it to the normal position, return the change lever, and return the bending rod to the start point.
6. Repeat steps 1 to 5 until the oil level does not go down and supply oil. The internal air flows out and oil is supplied while steps 1 to 5 described above are repeated.
7. Put the arm set on ground, stand the machine, execute steps 1 to 5 again, and make air escape completely. The oil supply is then completed. If air is left, the hydraulic pump cannot show its ability to the full.

NOTE: Only pure hydraulic oil as recommended by Ogura & Company Ltd. should be used in this tool. Use Ogura supplied hydraulic oil, Super Hyrando #46 (JX Nippon Oil & Energy Corp.) or anti-wear Hydraulic Oil, ISO Viscosity Grade 46. Do not use any other oil as this may cause damage to the gaskets and other internal machine parts.

Ogura®

2661 Hongo Ebina City,
Kanagawa-pref., Japan 243-0417
TEL : 046-238-1284 FAX : 046-238-4188

SO.8503070/1211