

SCANNED  
783

INSTRUCTION MANUAL



## Cordless Combination Hammer

DHR242  
DHR243

Drill / Hammer SDS Multi Cordless

Plant No. 06 167 007.

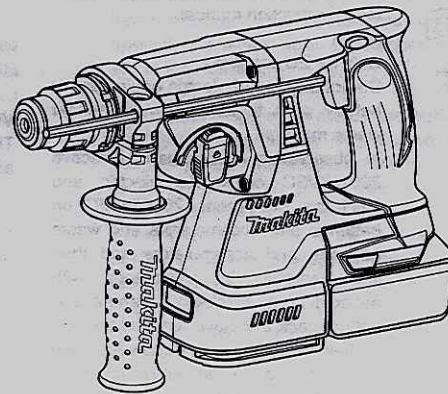

012621

## SPECIFICATIONS

Model		DHR242	DHR243
Capacities	Concrete	24 mm	
	Steel	13 mm	
	Wood	27 mm	
No load speed (min <sup>-1</sup> )		0 - 950	
Blows per minute		0 - 4,700	
Overall length		328 mm	353 mm
Net weight		3.3 kg	3.4 kg
Rated voltage		D.C. 18 V	

- Due to our continuing program of research and development, the specifications herein are subject to change without notice.
- Specifications and battery cartridge may differ from country to country.
- Weight, with battery cartridge, according to EPTA-Procedure 01/2003

END004-4

## Symbols

The following show the symbols used for the equipment. Be sure that you understand their meaning before use.



Read instruction manual.



Only for EU countries

Do not dispose of electric equipment or battery pack together with household waste material!

In observance of European Directive 2002/96/EC on waste electric and electronic equipment, 2006/66/EC on batteries and accumulators and waste batteries and accumulators and their implementation in accordance with national laws, electric equipment and battery pack that have reached the end of their life must be collected separately and returned to an environmentally compatible recycling facility.

ENE043-1

## Intended use

The tool is intended for hammer drilling and drilling in brick, concrete and stone as well as for chiselling work. It is also suitable for drilling without impact in wood, metal, ceramic and plastic.

ENG905-1

## Noise

The typical A-weighted noise level determined according to EN60745:

### Model DHR242

Sound pressure level (L<sub>PA</sub>): 90 dB(A)  
 Sound power level (L<sub>WA</sub>): 101 dB(A)  
 Uncertainty (K): 3 dB(A)

### Model DHR243

Sound pressure level (L<sub>PA</sub>): 89 dB(A)  
 Sound power level (L<sub>WA</sub>): 100 dB(A)  
 Uncertainty (K): 3 dB(A)

### Wear ear protection

ENG900-1

## Vibration

The vibration total value (tri-axial vector sum) determined according to EN60745:

### Model DHR242

Work mode : hammer drilling into concrete  
 Vibration emission (a<sub>h,HD</sub>): 13.5 m/s<sup>2</sup>  
 Uncertainty (K): 1.5 m/s<sup>2</sup>

Work mode : chiselling  
 Vibration emission (a<sub>h,CHeq</sub>): 10.5 m/s<sup>2</sup>  
 Uncertainty (K): 1.5 m/s<sup>2</sup>

Work mode: drilling into metal  
 Vibration emission (a<sub>r,D</sub>): 3.5 m/s<sup>2</sup>  
 Uncertainty (K): 1.5 m/s<sup>2</sup>

### Model DHR243

Work mode : hammer drilling into concrete  
 Vibration emission (a<sub>h,HD</sub>): 13 m/s<sup>2</sup>  
 Uncertainty (K): 1.5 m/s<sup>2</sup>

Work mode : chiselling  
 Vibration emission (a<sub>h,CHeq</sub>): 11 m/s<sup>2</sup>  
 Uncertainty (K): 1.5 m/s<sup>2</sup>

Work mode: drilling into metal  
 Vibration emission (a<sub>r,D</sub>): 2.5 m/s<sup>2</sup> or less  
 Uncertainty (K): 1.5 m/s<sup>2</sup>

- The declared vibration emission value has been measured in accordance with the standard test method and may be used for comparing one tool with another.
- The declared vibration emission value may also be used in a preliminary assessment of exposure.

## WARNING:

- The vibration emission during actual use of the power tool can differ from the declared emission value depending on the ways in which the tool is used.
- Be sure to identify safety measures to protect the operator that are based on an estimation of exposure in the actual conditions of use (taking account of all parts of the operating cycle such as the times when the tool is switched off and when it is running idle in addition to the trigger time).

ENH101-15

## For European countries only

### EC Declaration of Conformity

We Makita Corporation as the responsible manufacturer declare that the following Makita machine(s):

Designation of Machine:  
 Cordless Combination Hammer  
 Model No./ Type: DHR242, DHR243  
 are of series production and

Conforms to the following European Directives:  
 2006/42/EC

And are manufactured in accordance with the following standards or standardised documents:

EN60745

The technical documentation is kept by our authorised representative in Europe who is:

Makita International Europe Ltd.  
 Michigan Drive, Tongwell,  
 Milton Keynes, Bucks MK15 8JD, England

6.21.2011

000230

Tomoyasu Kato  
 Director

Makita Corporation  
 3-11-8, Sumiyoshi-cho,  
 Anjo, Aichi, 446-8502, JAPAN

## General Power Tool Safety Warnings

**⚠ WARNING** Read all safety warnings and all instructions. Failure to follow the warnings and instructions may result in electric shock, fire and/or serious injury.

## Save all warnings and instructions for future reference.

The term "power tool" in the warnings refers to your mains-operated (corded) power tool or battery-operated (cordless) power tool.

### Work area safety

1. **Keep work area clean and well lit.** Cluttered or dark areas invite accidents.
2. **Do not operate power tools in explosive atmospheres, such as in the presence of flammable liquids, gases or dust.** Power tools create sparks which may ignite the dust or fumes.
3. **Keep children and bystanders away while operating a power tool.** Distractions can cause you to lose control.

### Electrical safety

4. **Power tool plugs must match the outlet. Never modify the plug in any way. Do not use any adapter plugs with earthed (grounded) power tools.** Unmodified plugs and matching outlets will reduce risk of electric shock.
5. **Avoid body contact with earthed or grounded surfaces such as pipes, radiators, ranges and refrigerators.** There is an increased risk of electric shock if your body is earthed or grounded.
6. **Do not expose power tools to rain or wet conditions.** Water entering a power tool will increase the risk of electric shock.
7. **Do not abuse the cord. Never use the cord for carrying, pulling or unplugging the power tool. Keep cord away from heat, oil, sharp edges or moving parts.** Damaged or entangled cords increase the risk of electric shock.
8. **When operating a power tool outdoors, use an extension cord suitable for outdoor use.** Use of a cord suitable for outdoor use reduces the risk of electric shock.
9. **If operating a power tool in a damp location is unavoidable, use a ground fault circuit interrupter (GFCI) protected supply.** Use of an GFCI reduces the risk of electric shock.

### Personal safety

10. **Stay alert, watch what you are doing and use common sense when operating a power tool. Do not use a power tool while you are tired or**

under the influence of drugs, alcohol or medication. A moment of inattention while operating power tools may result in serious personal injury.

11. **Use personal protective equipment. Always wear eye protection.** Protective equipment such as dust mask, non-skid safety shoes, hard hat, or hearing protection used for appropriate conditions will reduce personal injuries.
12. **Prevent unintentional starting. Ensure the switch is in the off-position before connecting to power source and/or battery pack, picking up or carrying the tool.** Carrying power tools with your finger on the switch or energising power tools that have the switch on invites accidents.
13. **Remove any adjusting key or wrench before turning the power tool on.** A wrench or a key left attached to a rotating part of the power tool may result in personal injury.
14. **Do not overreach. Keep proper footing and balance at all times.** This enables better control of the power tool in unexpected situations.
15. **Dress properly. Do not wear loose clothing or jewellery. Keep your hair, clothing, and gloves away from moving parts.** Loose clothes, jewellery or long hair can be caught in moving parts.
16. **If devices are provided for the connection of dust extraction and collection facilities, ensure these are connected and properly used.** Use of dust collection can reduce dust-related hazards.

#### Power tool use and care

17. **Do not force the power tool. Use the correct power tool for your application.** The correct power tool will do the job better and safer at the rate for which it was designed.
18. **Do not use the power tool if the switch does not turn it on and off.** Any power tool that cannot be controlled with the switch is dangerous and must be repaired.
19. **Disconnect the plug from the power source and/or the battery pack from the power tool before making any adjustments, changing accessories, or storing power tools.** Such preventive safety measures reduce the risk of starting the power tool accidentally.
20. **Store idle power tools out of the reach of children and do not allow persons unfamiliar with the power tool or these instructions to operate the power tool.** Power tools are dangerous in the hands of untrained users.
21. **Maintain power tools. Check for misalignment or binding of moving parts, breakage of parts and any other condition that may affect the power tool's operation. If damaged, have the**

power tool repaired before use. Many accidents are caused by poorly maintained power tools.

22. **Keep cutting tools sharp and clean.** Properly maintained cutting tools with sharp cutting edges are less likely to bind and are easier to control.
  23. **Use the power tool, accessories and tool bits etc. in accordance with these instructions, taking into account the working conditions and the work to be performed.** Use of the power tool for operations different from those intended could result in a hazardous situation.
- #### Battery tool use and care
24. **Recharge only with the charger specified by the manufacturer.** A charger that is suitable for one type of battery pack may create a risk of fire when used with another battery pack.
  25. **Use power tools only with specifically designated battery packs.** Use of any other battery packs may create a risk of injury and fire.
  26. **When battery pack is not in use, keep it away from other metal objects, like paper clips, coins, keys, nails, screws or other small metal objects, that can make a connection from one terminal to another.** Shorting the battery terminals together may cause burns or a fire.
  27. **Under abusive conditions, liquid may be ejected from the battery; avoid contact. If contact accidentally occurs, flush with water. If liquid contacts eyes, additionally seek medical help.** Liquid ejected from the battery may cause irritation or burns.

#### Service

28. **Have your power tool serviced by a qualified repair person using only identical replacement parts.** This will ensure that the safety of the power tool is maintained.
29. **Follow instruction for lubricating and changing accessories.**
30. **Keep handles dry, clean and free from oil and grease.**

GEB046-2

## CORDLESS ROTARY HAMMER SAFETY WARNINGS

1. **Wear ear protectors.** Exposure to noise can cause hearing loss.
2. **Use auxiliary handle(s), if supplied with the tool.** Loss of control can cause personal injury.
3. **Hold power tool by insulated gripping surfaces, when performing an operation where the cutting accessory may contact hidden wiring.** Cutting accessory contacting a "live" wire may make exposed metal parts of the power tool "live" and could give the operator an electric shock.

4. **Wear a hard hat (safety helmet), safety glasses and/or face shield. Ordinary eye or sun glasses are NOT safety glasses. It is also highly recommended that you wear a dust mask and thickly padded gloves.**
5. **Be sure the bit is secured in place before operation.**
6. **Under normal operation, the tool is designed to produce vibration. The screws can come loose easily, causing a breakdown or accident. Check tightness of screws carefully before operation.**
7. **In cold weather or when the tool has not been used for a long time, let the tool warm up for a while by operating it under no load. This will loosen up the lubrication. Without proper warm-up, hammering operation is difficult.**
8. **Always be sure you have a firm footing. Be sure no one is below when using the tool in high locations.**
9. **Hold the tool firmly with both hands.**
10. **Keep hands away from moving parts.**
11. **Do not leave the tool running. Operate the tool only when hand-held.**
12. **Do not point the tool at any one in the area when operating. The bit could fly out and injure someone seriously.**
13. **Do not touch the bit or parts close to the bit immediately after operation; they may be extremely hot and could burn your skin.**
14. **Some material contains chemicals which may be toxic. Take caution to prevent dust inhalation and skin contact. Follow material supplier safety data.**

## SAVE THESE INSTRUCTIONS.

### ⚠WARNING:

DO NOT let comfort or familiarity with product (gained from repeated use) replace strict adherence to safety rules for the subject product. MISUSE or failure to follow the safety rules stated in this instruction manual may cause serious personal injury.

ENC007-7

## IMPORTANT SAFETY INSTRUCTIONS

### FOR BATTERY CARTRIDGE

1. **Before using battery cartridge, read all instructions and cautionary markings on (1) battery charger, (2) battery, and (3) product using battery.**

2. **Do not disassemble battery cartridge.**
3. **If operating time has become excessively shorter, stop operating immediately. It may result in a risk of overheating, possible burns and even an explosion.**
4. **If electrolyte gets into your eyes, rinse them out with clear water and seek medical attention right away. It may result in loss of your eyesight.**
5. **Do not short the battery cartridge:**
  - (1) **Do not touch the terminals with any conductive material.**
  - (2) **Avoid storing battery cartridge in a container with other metal objects such as nails, coins, etc.**
  - (3) **Do not expose battery cartridge to water or rain.**

**A battery short can cause a large current flow, overheating, possible burns and even a breakdown.**
6. **Do not store the tool and battery cartridge in locations where the temperature may reach or exceed 50 ° C (122 ° F).**
7. **Do not incinerate the battery cartridge even if it is severely damaged or is completely worn out. The battery cartridge can explode in a fire.**
8. **Be careful not to drop or strike battery.**
9. **Do not use a damaged battery.**

## SAVE THESE INSTRUCTIONS.

### Tips for maintaining maximum battery life

1. **Charge the battery cartridge before completely discharged. Always stop tool operation and charge the battery cartridge when you notice less tool power.**
2. **Never recharge a fully charged battery cartridge. Overcharging shortens the battery service life.**
3. **Charge the battery cartridge with room temperature at 10 ° C - 40 ° C (50 ° F - 104 ° F). Let a hot battery cartridge cool down before charging it.**
4. **Charge the battery cartridge once in every six months if you do not use it for a long period of time.**

## FUNCTIONAL DESCRIPTION

### ⚠CAUTION:

- Always be sure that the tool is switched off and the battery cartridge is removed before adjusting or checking function on the tool.

### Installing or removing battery cartridge

### ⚠CAUTION:

- Hold the tool and the battery cartridge firmly when installing or removing battery cartridge. Failure to hold the tool and the battery cartridge firmly may cause them to slip off your hands and result in damage to the tool and battery cartridge and a personal injury.

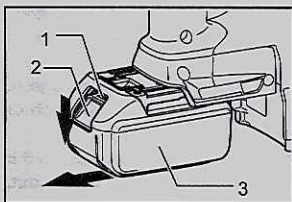

1. Red indicator
2. Button
3. Battery cartridge

012622

- Always switch off the tool before installing or removing of the battery cartridge.
- To remove the battery cartridge, slide it from the tool while sliding the button on the front of the cartridge.
- To install the battery cartridge, align the tongue on the battery cartridge with the groove in the housing and slip it into place. Always insert it all the way until it locks in place with a little click. If you can see the red indicator on the upper side of the button, it is not locked completely. Install it fully until the red indicator cannot be seen. If not, it may accidentally fall out of the tool, causing injury to you or someone around you.
- Do not use force when installing the battery cartridge. If the cartridge does not slide in easily, it is not being inserted correctly.

### Battery protection system (Lithium-ion battery with star marking)

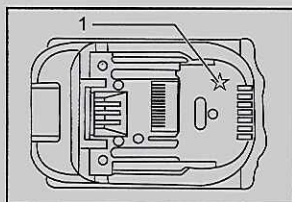

1. Star marking

012128

Lithium-ion batteries with a star marking are equipped with a protection system. This system automatically cuts off power to the tool to extend battery life.

The tool will automatically stop during operation if the tool and/or battery are placed under one of the following conditions:

- Overloaded:**  
The tool is operated in a manner that causes it to draw an abnormally high current. In this situation, release the trigger switch on the tool and stop the application that caused the tool to become overloaded. Then pull the trigger switch again to restart. If the tool does not start, the battery is overheated. In this situation, let the battery cool before pulling the trigger switch again.
- Low battery voltage:**  
The remaining battery capacity is too low and the tool will not operate. In this situation, remove and recharge the battery.

### Switch action

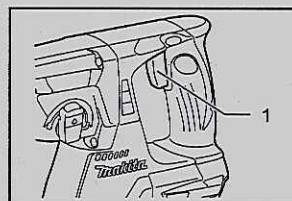

1. Switch trigger

012627

### ⚠CAUTION:

- Before inserting the battery cartridge into the tool, always check to see that the switch trigger actuates properly and returns to the "OFF" position when released.

To start the tool, simply pull the switch trigger. Tool speed is increased by increasing pressure on the switch trigger. Release the switch trigger to stop.

### Reversing switch action

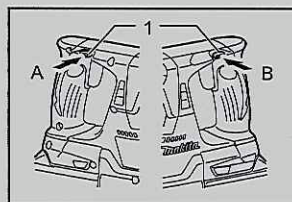

1. Reversing switch lever

012628

This tool has a reversing switch to change the direction of rotation. Depress the reversing switch lever from the A side for clockwise rotation or from the B side for counterclockwise rotation.

When the reversing switch lever is in the neutral position, the switch trigger cannot be pulled.

### ⚠CAUTION:

- Always check the direction of rotation before operation.
- Use the reversing switch only after the tool comes to a complete stop. Changing the direction of rotation before the tool stops may damage the tool.
- When not operating the tool, always set the reversing switch lever to the neutral position.

### Changing the quick change chuck for SDS-plus

#### For model DHR243

The quick change chuck for SDS-plus can be easily exchanged for the quick change drill chuck.

#### Removing the quick change chuck for SDS-plus

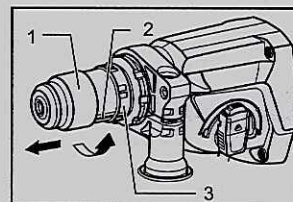

1. Quick change chuck for SDS-plus
2. Change cover line
3. Change cover

012690

### ⚠CAUTION:

- Before removing the quick change chuck for SDS-plus, always remove the bit.

Grasp the change cover of the quick change chuck for SDS-plus and turn in the direction of the arrow until the change cover line moves from the symbol to the symbol. Pull forcefully in the direction of the arrow.

#### Attaching the quick change drill chuck

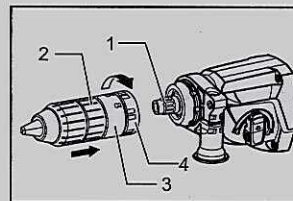

1. Spindle
2. Quick change drill chuck
3. Change cover
4. Change cover line

012689

Check the line of the quick change drill chuck shows the symbol. Grasp the change cover of the quick change drill chuck and set the line to the symbol. Place the quick change drill chuck on the spindle of the tool.

Grasp the change cover of the quick change drill chuck and turn the change cover line to the symbol until a click can clearly be heard.

### Selecting the action mode Rotation with hammering

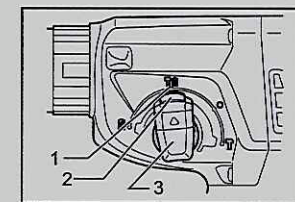

1. Rotation with hammering
2. Lock button
3. Action mode changing knob

012629

For drilling in concrete, masonry, etc., depress the lock button and rotate the action mode changing knob to the symbol. Use a tungsten-carbide tipped bit.

#### Rotation only

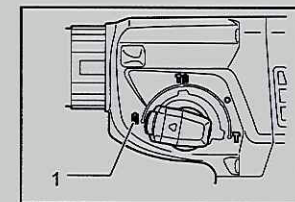

1. Rotation only

012631

For drilling in wood, metal or plastic materials, depress the lock button and rotate the action mode changing knob to the symbol. Use a twist drill bit or wood bit.

#### Hammering only

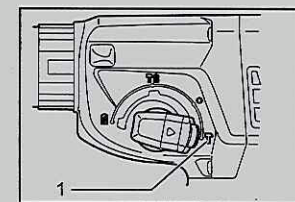

1. Hammering only

012630

For chipping, scaling or demolition operations, depress the lock button and rotate the action mode changing knob to the symbol. Use a bull point, cold chisel, scaling chisel, etc.

### ⚠CAUTION:

- Do not rotate the action mode changing knob when the tool is running. The tool will be damaged.
- To avoid rapid wear on the mode change mechanism, be sure that the action mode changing knob is always positively located in one of the three action mode positions.
- When changing from the mode to the symbol mode, the action mode changing knob may no longer move in the position. At

this time, turn the tool on or turn the chuck by hand in the  symbol position and then rotate the action mode changing knob. Forcing the action mode changing knob may cause tool damage.

### Torque limiter

The torque limiter will actuate when a certain torque level is reached. The motor will disengage from the output shaft. When this happens, the bit will stop turning.

### CAUTION:

- As soon as the torque limiter actuates, switch off the tool immediately. This will help prevent premature wear of the tool.
- Hole saws cannot be used with this tool. They tend to pinch or catch easily in the hole. This will cause the torque limiter to actuate too frequently.

## ASSEMBLY

### CAUTION:

- Always be sure that the tool is switched off and the battery cartridge is removed before carrying out any work on the tool.

### Side grip (auxiliary handle)

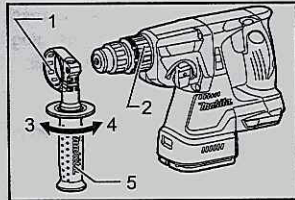

- Protusion
- Groove
- Loosen
- Tighten
- Side grip

012623

### CAUTION:

- Always use the side grip to ensure operating safety. Install the side grip so that the protusion on the grip fit in between the grooves in the tool barrel. Then tighten the grip by turning clockwise at the desired position. It may be swung 360° so as to be secured at any position.

### Bit grease

Coat the bit shank head beforehand with a small amount of bit grease (about 0.5 -1 g). This chuck lubrication assures smooth action and longer service life.

### Installing or removing the bit

Clean the bit shank and apply bit grease before installing the bit.

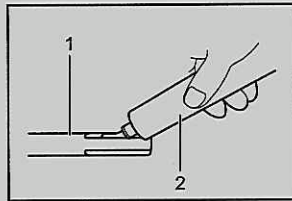

- Bit shank
- Bit grease

001296

Insert the bit into the tool. Turn the bit and push it in until it engages.

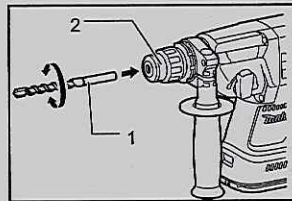

- Bit
- Chuck cover

012624

If the bit cannot be pushed in, remove the bit. Pull the chuck cover down a couple of times. Then insert the bit again. Turn the bit and push it in until it engages.

After installing, always make sure that the bit is securely held in place by trying to pull it out.

To remove the bit, pull the chuck cover down all the way and pull the bit out.

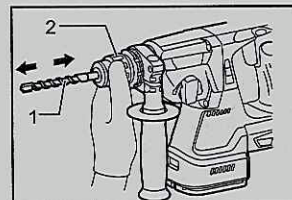

- Bit
- Chuck cover

012625

### Bit angle (when chipping, scaling or demolishing)

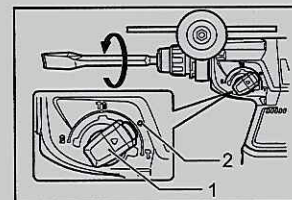

- Action mode changing knob
- O symbol

012632

The bit can be secured at the desired angle. To change the bit angle, depress the lock button and rotate the action mode changing knob to the  symbol. Turn the bit to the desired angle.

Depress the lock button and rotate the action mode changing knob to the  symbol. Then make sure that the bit is securely held in place by turning it slightly.

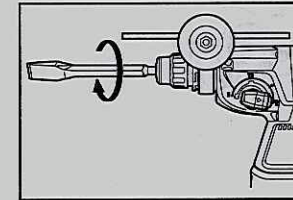

012633

### Depth gauge

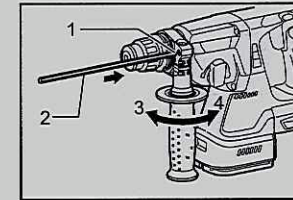

- Hole
- Depth gauge
- Loosen
- Tighten

012626

The depth gauge is convenient for drilling holes of uniform depth. Loosen the side grip and insert the depth gauge into the hole in the side grip. Adjust the depth gauge to the desired depth and tighten the side grip.

### NOTE:

- The depth gauge cannot be used at the position where the depth gauge strikes against the gear housing.

### Dust cup

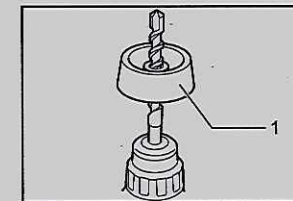

- Dust cup

012636

Use the dust cup to prevent dust from falling over the tool and on yourself when performing overhead drilling operations. Attach the dust cup to the bit as shown in the figure. The size of bits which the dust cup can be attached to is as follows.

	Bit diameter
Dust cup 5	6 mm - 14.5 mm
Dust cup 9	12 mm - 16 mm

006382

## OPERATION

### Hammer drilling operation

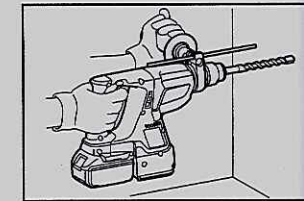

012634

Set the action mode changing knob to the  symbol. Position the bit at the desired location for the hole, then pull the switch trigger.

Do not force the tool. Light pressure gives best results. Keep the tool in position and prevent it from slipping away from the hole.

Do not apply more pressure when the hole becomes clogged with chips or particles. Instead, run the tool at an idle, then remove the bit partially from the hole. By repeating this several times, the hole will be cleaned out and normal drilling may be resumed.

### CAUTION:

- There is a tremendous and sudden twisting force exerted on the tool/bit at the time of hole break-through, when the hole becomes clogged with chips and particles, or when striking reinforcing rods embedded in the concrete. Always use the side grip (auxiliary handle) and firmly hold the tool by both side grip and switch handle during operations. Failure to do so may result in the loss of control of the tool and potentially severe injury.

### NOTE:

Eccentricity in the bit rotation may occur while operating the tool with no load. The tool automatically centers itself during operation. This does not affect the drilling precision.

### Blow-out bulb (optional accessory)

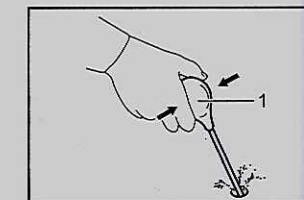

- Blow-out bulb

002449

After drilling the hole, use the blow-out bulb to clean the dust out of the hole.

## Chipping/Scaling/Demolition

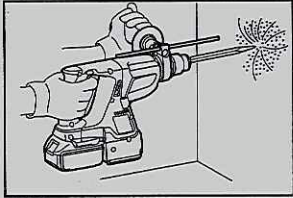

012686

Set the action mode changing knob to the  symbol. Hold the tool firmly with both hands. Turn the tool on and apply slight pressure on the tool so that the tool will not bounce around, uncontrolled. Pressing very hard on the tool will not increase the efficiency.

## Drilling in wood or metal

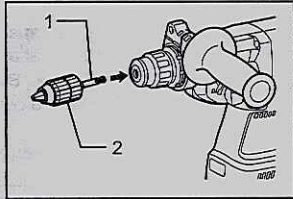

012684

1. Chuck adapter
2. Keyless drill chuck

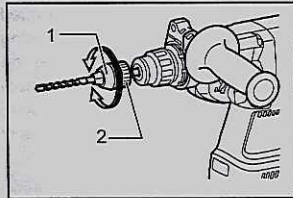

012685

1. Sleeve
2. Ring

Use the optional drill chuck assembly. When installing it, refer to "Installing or removing the bit" described on the previous page.

Set the action mode changing knob so that the pointer points to the  symbol.

For model DHR243

### ⚠CAUTION:

- Never use "rotation with hammering" when the drill chuck assembly is installed on the tool. The drill chuck assembly may be damaged. Also, the drill chuck will come off when reversing the tool.

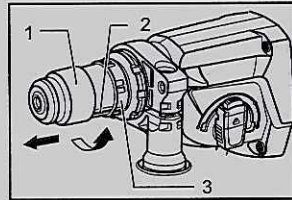

012690

1. Quick change chuck for SDS-plus
2. Change cover line
3. Change cover

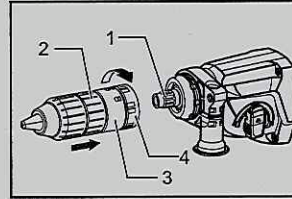

012689

1. Spindle
2. Quick change drill chuck
3. Change cover
4. Change cover line

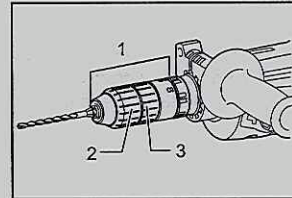

012720

1. Quick change drill chuck
2. Sleeve
3. Ring

Hold the ring and turn the sleeve counterclockwise to open the chuck jaws. Place the bit in the chuck as far as it will go. Hold the ring firmly and turn the sleeve clockwise to tighten the chuck. To remove the bit, hold the ring and turn the sleeve counterclockwise.

Set the action mode changing knob to the  symbol. You can drill up to 13 mm diameter in metal and up to 32 mm diameter in wood.

### ⚠CAUTION:

- Never use "rotation with hammering" when the quick change drill chuck is installed on the tool. The quick change drill chuck may be damaged. Also, the drill chuck will come off when reversing the tool.
- Pressing excessively on the tool will not speed up the drilling. In fact, this excessive pressure will only serve to damage the tip of your bit, decrease the tool performance and shorten the service life of the tool.
- There is a tremendous twisting force exerted on the tool/bit at the time of hole breakthrough. Hold the

tool firmly and exert care when the bit begins to break through the workpiece.

- A stuck bit can be removed simply by setting the reversing switch to reverse rotation in order to back out. However, the tool may back out abruptly if you do not hold it firmly.
- Always secure small workpieces in a vise or similar hold-down device.

### NOTE:

- Some items in the list may be included in the tool package as standard accessories. They may differ from country to country.

## MAINTENANCE

### ⚠CAUTION:

- Always be sure that the tool is switched off and the battery cartridge is removed before attempting to perform inspection or maintenance.
- Never use gasoline, benzine, thinner, alcohol or the like. Discoloration, deformation or cracks may result.

To maintain product SAFETY and RELIABILITY, repairs, carbon brush inspection and replacement, any other maintenance or adjustment should be performed by Makita Authorized Service Centers, always using Makita replacement parts.

## OPTIONAL ACCESSORIES

### ⚠CAUTION:

- These accessories or attachments are recommended for use with your Makita tool specified in this manual. The use of any other accessories or attachments might present a risk of injury to persons. Only use accessory or attachment for its stated purpose.

If you need any assistance for more details regarding these accessories, ask your local Makita Service Center.

- SDS-Plus Carbide-tipped bits
- Bull point
- Cold chisel
- Scaling chisel
- Grooving chisel
- Drill chuck assembly
- Drill chuck S13
- Chuck adapter
- Chuck key S13
- Bit grease
- Side grip
- Depth gauge
- Blow-out bulb
- Dust cup
- Dust extractor attachment
- Safety goggles
- Plastic carrying case
- Keyless drill chuck
- Various type of Makita genuine batteries and chargers



**DC18RA**  
**DC18RC**

**GB** **Fast Charger**

**D** **Schnellladegerät**

**PL** **Szybka ładowarka**

**RU** **Зарядное устройство для быстрой зарядки**

### Symbols

The followings show the symbols used for the equipment. Be sure that you understand their meaning before use.

### Symbole

Die folgenden Symbole werden für das Gerät verwendet. Machen Sie sich vor der Benutzung unbedingt mit ihrer Bedeutung vertraut.

### Symbole

Poniższe symbole używane są do opisu urządzenia. Przed użyciem należy upewnić się, że rozumie się ich znaczenie.

### Символы

Следующие объяснения показывают символы, используемые для оборудования. Убедитесь перед использованием, что Вы понимаете их значение.



- Indoor use only
- Nur für trockene Räume
- Tylko do użytku w pomieszczeniach
- Использование только внутри помещения



- Read instruction manual
- Bitte Betriebsanleitung lesen
- Przeczytaj instrukcję obsługi
- Прочитайте инструкцию по эксплуатации



- DOUBLE INSULATION
- DOPPELT SCHUTZISOLIERT
- PODWÓJNA IZOLACJA
- ДВОЙНАЯ ИЗОЛЯЦИЯ



- Delay charge (Battery cooling or too cold battery)
- Ladungsverzögerung (Akku ist abgekühlt oder zu kalt)
- Ładowanie opóźnione (Trwa chłodzenie akumulatora lub zbyt niska temperatura akumulatora)
- Задержка зарядки (Охлаждение батареи или слишком холодная батарея)



- Defective battery
- Akku defekt
- Uszkodzony akumulator
- Дефектная батарея



- Conditioning
- Anpassungsladung
- Ładowanie optymalne
- Кондиционирование



- Cooling abnormality
- Kühlungsstörung
- Nieprawidłowość w chłodzeniu
- Неисправность охлаждения



- Do not destroy battery by fire.
- Werfen Sie die Batterie nicht ins Feuer.
- Nie uszkodzaj akumulatora przez kontakt z ogniem.
- Не сжигайте батарею.



- Do not expose battery to water or rain.
- Setzen Sie die Batterie weder Wasser noch Regen aus.
- Nie wystawiaj akumulatora na działanie wody lub deszczu.
- Не подвергайте батарею воздействию воды или дождя.



- Do not short batteries.
- Schließen Sie die Kontakte nicht kurz. Brandgefahr!
- Nie zwieraj akumulatorów.
- Не закорачивайте батареи.



- Always recycle batteries.
- Verbrauchte Akkus stets dem Recycling zuführen.
- Zawsze kieruj akumulatory do odzysku.
- Всегда выбрасывайте батареи для рециркуляции.

NI-MH  
Li-ion



- Only for EU countries

Do not dispose of electric equipment or battery pack together with household waste material!  
In observance of the European Directives, on Waste Electric and Electronic Equipment and Batteries and Accumulators and Waste Batteries and Accumulators and their implementation in accordance with national laws, electric equipment and batteries and battery pack(s) that have reached the end of their life must be collected separately and returned to an environmentally compatible recycling facility.

- Nur für EU-Länder

Werfen Sie Elektrogeräte oder Akkus nicht in den Hausmüll!  
Gemäß den Europäischen Richtlinien für Elektro- und Elektronik-Altgeräte, für Batterien, Akkus sowie verbrauchte Batterien und Akkus und ihre Umsetzung gemäß den Landesgesetzen müssen Elektrogeräte, Batterien und Akkus, die das Ende ihrer Lebensdauer erreicht haben, getrennt gesammelt und einer umweltgerechten Recycling-Einrichtung zugeführt werden.

- Dotyczy tylko państw UE

Nie wyrzucać urządzeń elektrycznych ani akumulatorów wraz z odpadami z gospodarstwa domowego!

Zgodnie z dyrektywami w sprawie zużytego sprzętu elektrycznego i elektronicznego, jak również w sprawie akumulatorów i baterii oraz zużytych akumulatorów i baterii, oraz dostosowaniem ich do prawa krajowego, zużyte urządzenia elektryczne oraz baterie i akumulatory po zakończeniu okresu ich użytkowania należy segregować i przekazywać do odpowiedniego punktu zbiórki odpadów.

- Только для стран ЕС

Не утилизируйте электрическое оборудование или батарейный блок вместе с бытовым мусором!

Согласно Европейским Директивам об утилизации электрического и электронного оборудования, о батареях и аккумуляторах, об утилизации батарей и аккумуляторов, и для их выполнения в соответствии с государственными законами, электрическое оборудование, батареи и батарейный(е) блок(и), срок службы которых истек, должны быть отдельно собраны и возвращены в пункт утилизации вторично используемого сырья с соблюдением требований охраны окружающей среды.

## ENGLISH

### CAUTION:

1. SAVE THESE INSTRUCTIONS – This manual contains important safety and operating instructions for battery charger.
2. Before using battery charger, read all instructions and cautionary markings on (1) battery charger, (2) battery, and (3) product using battery.
3. CAUTION – To reduce risk of injury, charge only Makita type rechargeable batteries. Other types of batteries may burst causing personal injury and damage.
4. Non-rechargeable batteries cannot be charged with this battery charger.
5. Use a power source with the voltage specified on the nameplate of the charger.
6. Do not charge the battery cartridge in presence of flammable liquids or gases.
7. Do not expose charger to rain or snow.
8. Never carry charger by cord or yank it to disconnect from receptacle.
9. After charging or before attempting any maintenance or cleaning, unplug the charger from the power source. Pull by plug rather than cord whenever disconnecting charger.
10. Make sure cord is located so that it will not be stepped on, tripped over, or otherwise subjected to damage or stress.
11. Do not operate charger with damaged cord or plug. If the cord or plug is damaged, ask Makita authorized service center to replace it in order to avoid a hazard.
12. Do not operate or disassemble charger if it has received a sharp blow, been dropped, or otherwise damaged in any way; take it to a qualified serviceman. Incorrect use or reassembly may result in a risk of electric shock or fire.
13. This appliance is not intended for use by persons (including children) with reduced physical, sensory or mental capabilities, or lack of experience and knowledge, unless they have been given supervision or instruction concerning use of the appliance by a person responsible for their safety.
14. Children should be supervised to ensure that they do not play with the battery charger.
15. Do not charge battery cartridge when room temperature is BELOW 10°C (50°F) or ABOVE 40°C (104°F). When the battery temperature is under 0°C (32°F), charging may not start.
16. Do not attempt to use a step-up transformer, an engine generator or DC power receptacle.
17. Do not allow anything to cover or clog the charger vents.

### Charging

1. Plug the battery charger into the proper AC voltage source. Charging light will flash in green color repeatedly.
2. Insert the battery cartridge into charger until it stops adjusting to the guide of charger. Terminal cover of charger can be opened with inserting and closed with pulling out the battery cartridge.
3. When the battery cartridge is inserted, the red charging light will light up and charging will begin with a preset brief melody sound coming out for assurance as to which sound will come out to notify the completion of charging.
4. With finish of charge, the charging light will change from red one to green one and the melody sound or buzzer sound (a long beep) comes out to notify completion of charge.
5. Charging time varies by temperature (10°C (50°F) – 40°C (104°F)) that battery cartridge is charged at and conditions of the battery cartridge, such as a battery cartridge which is new or has not been used for a long period of time.
6. After charging, remove the battery cartridge from charger and unplug the charger.

### Changing melody of completed charging

1. Inserting the battery cartridge into charger brings out last preset brief melody sound of completed charging.
2. Removing and re-inserting it within five seconds after this action makes the melody sound change.
3. Every time removing and re-inserting it within another five seconds after this, the melody sound changes in order.
4. When the desired melody sound comes out, leave the battery cartridge being inserted and the charge will begin. When a "short beep" mode is selected, no completed charging signals comes out. (Silent Mode)
5. With finish of charge, the green light remains lit with the red light going out and the melody sound preset at the insertion of battery cartridge or buzzer sound (a long beep) comes out to notify completion of charge. (In selected silent mode, no sounds come out.)
6. Preset melody sound remains stored even when the charger is unplugged.

Voltage	9.6 V	12 V	14.4 V	Capacity (Ah)	Charging time (Minutes)
Number of cells	8	10	12		
Ni-MH Battery cartridge	B9017A	—	—	1.7	20
	BH9020/A	—	—	1.8 (IEC61951-2)	20
	—	BH1220/C	BH1420	1.8 (IEC61951-2)	15
	—	—	BH1427	2.5 (IEC61951-2)	20
	BH9033/A	—	—	3.1 (IEC61951-2)	30
	—	BH1233/C	BH1433	3.1 (IEC61951-2)	22

Voltage	14.4 V	18 V	14.4 V	18 V	Capacity (Ah) according to IEC61960	Charging time (Minutes)
Number of cells	4	5	8	10		
Li-ion Battery cartridge	BL1415	BL1815	—	—	1.3	15
	—	—	BL1430/A	BL1830	3.0	22
	BL1415NA	BL1815N	—	—	1.5	15
	—	BL1820*1	—	—	2.0	18
	—	—	BL1440*1	BL1840*1	4.0	36

\*1 These batteries can be charged with DC18RC only.

### NOTE:

- The battery charger is for charging Makita-battery cartridge. Never use it for other purposes or for other manufacturer's batteries.
- When you charge a battery cartridge which is new or has not been used for a long period of time, it may not accept a full charge until after discharging it completely and recharging a couple of times. (Ni-MH battery only)
- If charging light may flash in red color, battery condition is as below and charging may not start.
  - Battery cartridge from just-operated tool or battery cartridge that has been left in a location exposed to direct sunlight for a long time.
  - Battery cartridge that has been left for a long time in a location exposed to cold air.
 When the battery cartridge is too hot, charging will begin after the cooling fan installed in the charger cools the battery cartridge. Charging will begin after the battery cartridge temperature reaches the degree at which charging is possible.
- If the charging light flashes alternately in green and red color, charging is not possible. The terminals on the charger or battery cartridge are clogged with dust or the battery cartridge is worn out or damaged.

### Cooling system

- This charger is equipped with cooling fan for heated battery in order to enable the battery to prove its own performance. Sound of cooling air comes out during cooling, which means no trouble on the charger.
- Yellow light will flash for warning in the following cases.
  - Trouble on cooling fan
  - Incomplete cool down of battery, such as, being clogged with dust
 The battery can be charged in spite of the yellow warning light. But the charging time will be longer than usual in this case. Check the sound of cooling fan, vent on the charger, which can be sometime clogged with dust.
- The cooling system is in order although no sound of cooling fan comes out, if the yellow warning light will not flash.
- Always keep clean the vent on charger and battery for cooling.
- The products should be sent to repair or maintenance, if the yellow warning light will frequently flash.

### Conditioning charge

Conditioning charge can extend the life of battery by automatically searching the optimum charging condition for the batteries in every situation.

The battery employed in the following conditions repeatedly requires "conditioning charge" to prevent fast wear out. In that case, yellow light lights up.

1. Recharge of battery with its high temperature
2. Recharge of battery with its low temperature
3. Recharge of full charged battery
4. Over-discharge of battery (continue to discharge battery in spite of down of power.)

The charging time of such battery is longer than usual.