

# Makita

## Trimmer

Machine Type NO. 06225

Machine type: Trimmer 1/4"

Manual NO.: 417

R/A NO. 246

6 mm (1/4") MODEL 3701  
6 mm (1/4") MODEL N3701

### INSTRUCTION MANUAL

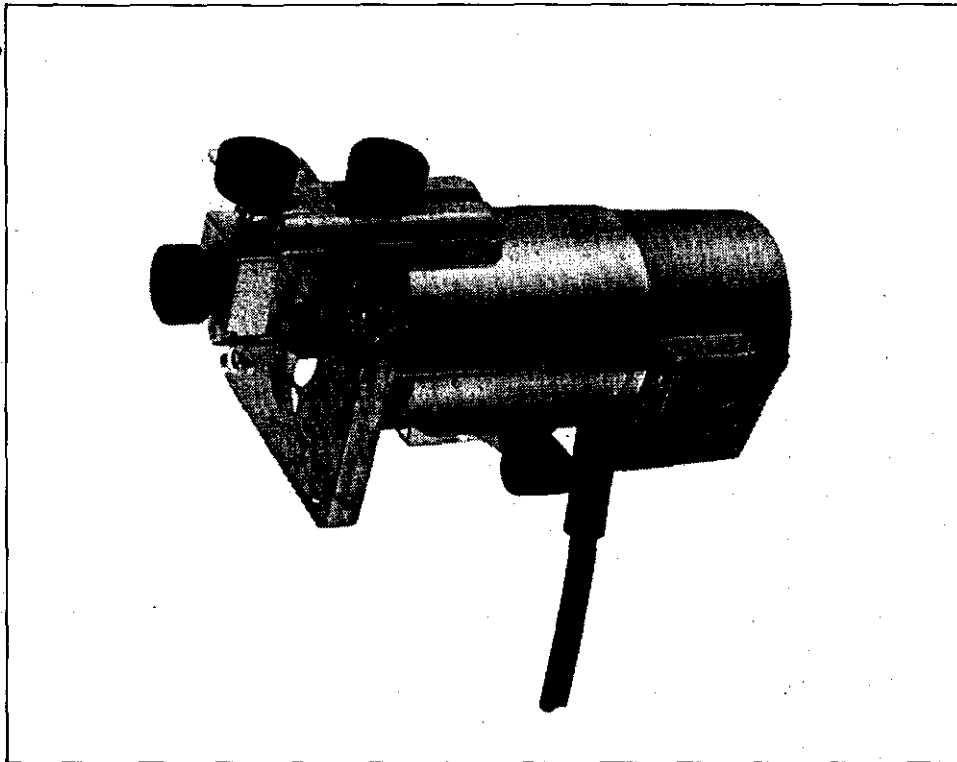

#### SPECIFICATIONS

Collet chuck capacity	No load speed (RPM)	Overall length	Net weight
6 mm or 1/4"	30,000	220 mm (8-5/8")	1.7 kg (3.7 lbs)

- Manufacturer reserves the right to change specifications without notice.
- Note: Specifications may differ from country to country.

## IMPORTANT SAFETY INSTRUCTIONS

**WARNING:** When using electric tools, basic safety precautions should always be followed to reduce the risk of fire, electric shock, and personal injury, including the following:

### READ ALL INSTRUCTIONS.

1. **KEEP WORK AREA CLEAN.** Cluttered areas and benches invite injuries.
2. **CONSIDER WORK AREA ENVIRONMENT.** Don't use power tools in damp or wet locations. Keep work area well lit. Don't expose power tools to rain. Don't use tool in presence of flammable liquids or gases.
3. **KEEP CHILDREN AWAY.** All visitors should be kept away from work area. Don't let visitors contact tool or extension cord.
4. **STORE IDLE TOOLS.** When not in use, tools should be stored in dry, and high or locked-up place — out of reach of children.
5. **DON'T FORCE TOOL.** It will do the job better and safer at the rate for which it was intended.
6. **USE RIGHT TOOL.** Don't force small tool or attachment to do the job of a heavy-duty tool. Don't use tool for purpose not intended.
7. **DRESS PROPERLY.** Don't wear loose clothing or jewelry. They can be caught in moving parts. Rubber gloves and non-skid footwear are recommended when working outdoors. Wear protective hair covering to contain long hair.
8. **USE SAFETY GLASSES.** Also use face or dust mask if cutting operation is dusty.
9. **DON'T ABUSE CORD.** Never carry tool by cord or yank it to disconnect from receptacle. Keep cord from heat, oil, and sharp edges.
10. **SECURE WORK.** Use clamps or a vise to hold work. It's safer than using your hand and it frees both hands to operate tool.
11. **DON'T OVERREACH.** Keep proper footing and balance at all times.
12. **MAINTAIN TOOLS WITH CARE.** Keep tools sharp and clean for better and safer performance. Follow instructions for lubricating and changing accessories. Inspect tool cords periodically and if damaged, have repaired by authorized service facility. Inspect extension cords periodically and replace if damaged. Keep handles dry, clean, and free from oil and grease.
13. **DISCONNECT TOOLS.** When not in use, before servicing, and when changing accessories, such as blades, bits, cutters.
14. **REMOVE ADJUSTING KEYS AND WRENCHES.** Form habit of checking to see that keys and adjusting wrenches are removed from tool before turning it on.
15. **AVOID UNINTENTIONAL STARTING.** Don't carry plugged-in tool with finger on switch. Be sure switch is OFF when plugging in.
16. **OUTDOOR USE EXTENSION CORDS.** When tool is used outdoors, use only extension cords intended for use outdoors and so marked.

17. **STAY ALERT.** Watch what you are doing, use common sense. Don't operate tool when you are tired.

18. **CHECK DAMAGED PARTS.** Before further use of the tool, a guard or other part that is damaged should be carefully checked to determine that it will operate properly and perform its intended function. Check for alignment of moving parts, binding of moving parts, breakage of parts, mounting, and any other conditions that may affect its operation. A guard or other part that is damaged should be properly repaired or replaced by an authorized service center unless otherwise indicated elsewhere in this instruction manual. Have defective switches replaced by authorized service center. Don't use tool if switch does not turn it on and off.

19. **GUARD AGAINST ELECTRIC SHOCK.** Prevent body contact with grounded surfaces. For example: pipes, radiators, ranges, refrigerator enclosures.

20. **PROPER GROUNDING.** This tool should be grounded while in use to protect the operator from electric shock.

21. **EXTENSION CORDS:** Use only three-wire extension cords which have three-prong grounding-type plugs and three-pole receptacles which accept the tool's plug. Replace or repair damaged or worn cord immediately.

**VOLTAGE WARNING:** Before connecting the tool to a power source (receptacle, outlet, etc.) be sure the voltage supplied is the same as that specified on the nameplate of the tool. A power source with voltage greater than that specified for the tool can result in **SERIOUS INJURY** to the user — as well as damage to the tool. If in doubt, **DO NOT PLUG IN THE TOOL.** Using a power source with voltage less than the nameplate rating is harmful to the motor.

## ADDITIONAL SAFETY RULES

1. Wear hearing protection during extended periods of operation.
2. Handle the bits very carefully.
3. Check the bit carefully for cracks or damage before operation. Replace cracked or damaged bit immediately.
4. Avoid cutting nails. Inspect for and remove all nails from the workpiece before operation.
5. Hold the tool firmly.
6. Keep hands away from rotating parts.
7. Make sure the bit is not contacting the workpiece before the switch is turned on.
8. Before using the tool on an actual workpiece, let it run for a while. Watch for vibration or wobbling that could indicate improperly installed bit.
9. Be careful of the bit rotating direction and the feed direction.
10. Do not leave the tool running. Operate the tool only when hand-held.
11. Always switch off and wait for the bit to come to a complete stop before removing the tool from workpiece.
12. Do not touch the bit immediately after operation; it may be extremely hot and could burn your skin.
13. Don't smear the tool base carelessly with thinner, gasoline, oil or the like. They may cause cracks in the tool base.

**SAVE THESE INSTRUCTIONS.**

### Installing or removing trimmer bit

#### CAUTION:

Always be sure that the tool is switched off and unplugged before installing or removing the bit.

Insert the bit all the way into the collet cone and tighten the collet nut securely with the two wrenches. To remove the bit, follow the installation procedure in reverse.

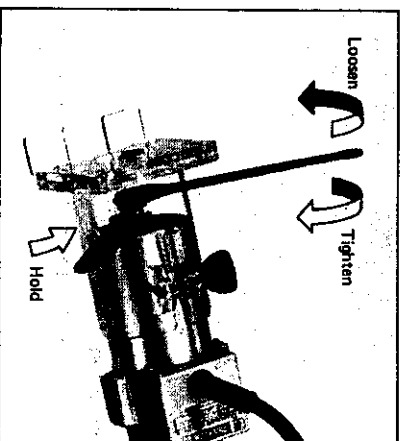

#### CAUTION:

Do not tighten the collet nut without inserting a bit, or the collet cone will break.

### Adjusting depth of cut

Place the tool on a flat surface. Loosen the clamp screw and move the tool body until the bit just touches the flat surface. Tighten the clamp screw slightly. Place the tool on its side and loosen the clamp screw. Move the tool base until the desired depth of cut is obtained. Depth of cut can be checked with the scale label (1 mm or about 3/64" per graduation) on the tool. Then tighten the clamp screw securely.



#### CAUTION:

Since excessive cutting may cause overload of the motor or difficulty in controlling the tool, the depth of cut should not be more than 3 mm (1/8") at a pass when cutting grooves. When you wish to cut grooves more than 3 mm (1/8") deep, make several passes with progressively deeper bit settings.

### Switch action

To start the tool, move the switch lever to the "ON" position. To stop, move the switch lever to the "OFF" position.



### Operation

- Set the tool base on the workpiece to be cut without the bit making any contact. Then turn the tool on and wait until the bit attains full speed. Move the tool forward over the workpiece surface, keeping the tool base flush and advancing smoothly until the cutting is complete.
- When doing edge cutting, the workpiece surface should be on the left side of the bit in the feed direction. (See the figure below)

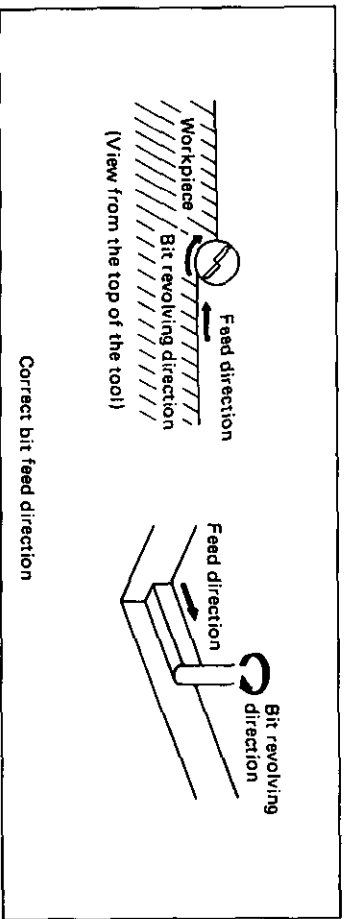

### NOTE:

- Moving the tool forward too fast may cause a poor quality of cut, or damage to the bit or motor. Moving the tool forward too slowly may burn and mar the cut. The proper feed rate will depend on the bit size, the kind of workpiece and depth of cut. Before beginning the cut on the actual workpiece, it is advisable to make a sample cut on a piece of scrap lumber. This will show exactly how the cut will look as well as enable you to check dimensions.
- When using the straight guide or the trimmer guide, be sure to install it on the right side in the feed direction. This will help to keep it flush with the side of the workpiece.

### Straight guide

The straight guide is effectively used for straight cuts when chamfering or grooving.



Attach the guide plate to the straight guide with the bolt, the wave washer, the flat washer and the wing nut.

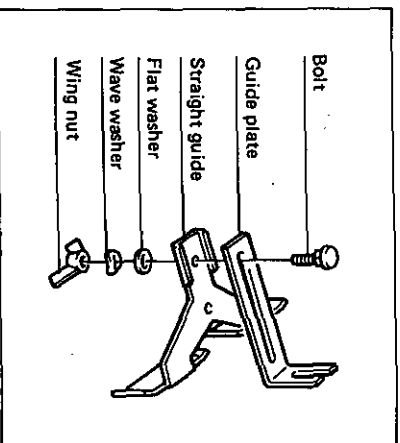

Remove the chip deflector. Attach the straight guide with the clamp screw (A). Loosen the wing nut on the guide and adjust the distance between the bit and the straight guide. At the desired distance, tighten the wing nut securely.

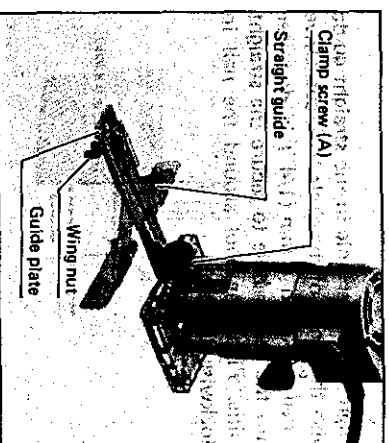

When cutting, move the tool with the straight guide flush with the side of the workpiece.

**Circular work**

- Circular work may be accomplished if you assemble the straight guide and guide plate as shown in the figure below.
- Min. and max. radius of circles to be cut (distance between the center of circle and the center of bit) are as follows:  
 Min.: 70 mm (2-3/4")  
 Max.: 221 mm (8-11/16")

(Note)

Circles between 172 mm (6-3/4") and 186 mm (7-5/16") in radius cannot be cut using this guide.

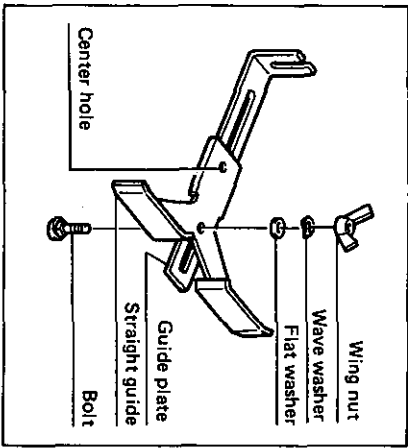

For cutting circles between 70 mm (2-3/4") and 121 mm (4-3/4") in radius.

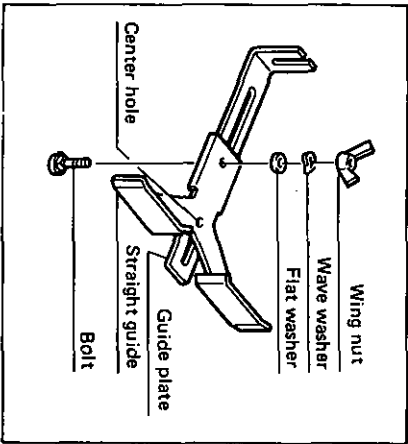

For cutting circles between 121 mm (4-3/4") and 221 mm (8-11/16") in radius.

Align the center hole in the straight guide with the center of the circle to be cut. Drive a nail less than 6 mm (1/4") in diameter into the center hole to secure the straight guide. Pivot the tool around the nail in clockwise direction.

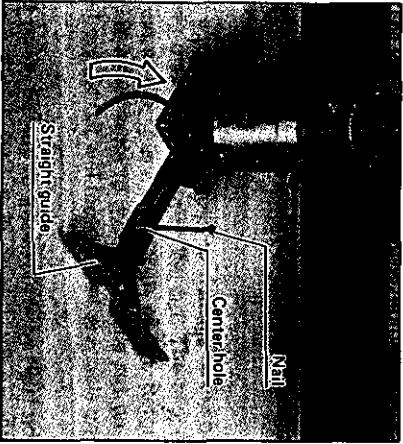

**Trimmer guide**

Trimming, curved cuts in veneers for furniture and the like can be done easily with the trimmer guide. The guide roller rides the curve and assures a fine cut.

Install the trimmer guide on the tool base with the clamp screw (A). Loosen the clamp screw (B) and adjust the distance between the bit and the trimmer guide by turning the adjusting screw (1 mm or about 3/64" per turn). At the desired distance, tighten the clamp screw (B) to secure the trimmer guide in place.

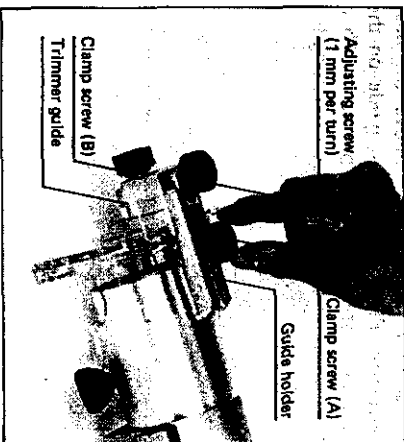
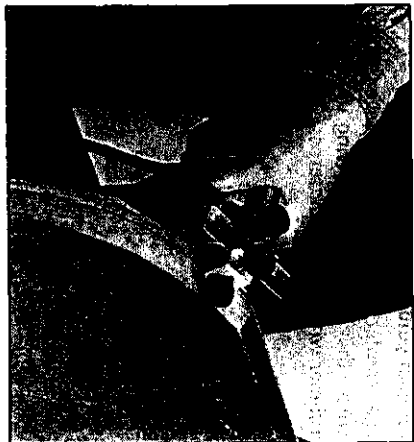

When cutting, move the tool with the guide roller riding the side of the workpiece.

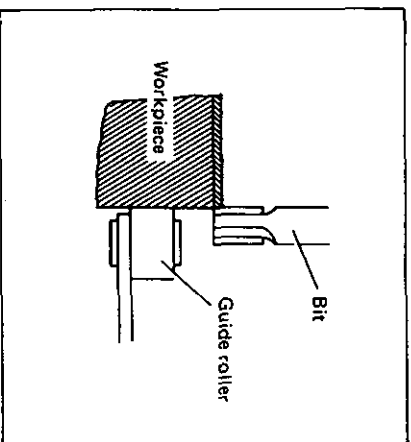

**Templet guide**  
 The templet guide provides a sleeve through which the bit passes, allowing use of the trimmer with templet patterns.

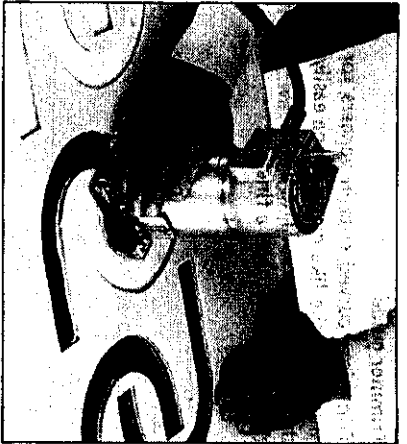

Loosen the screws and remove the base protector. Place the templet guide on the base and replace the base protector. Then secure the base protector by tightening the screws.

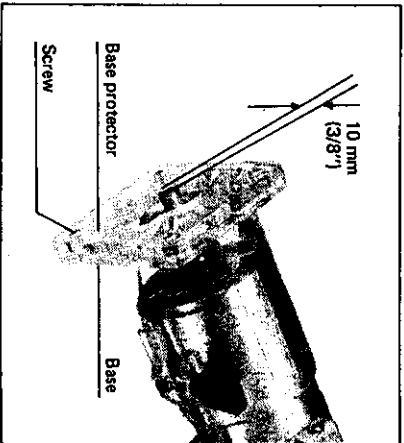

Secure the templet to the workpiece. Place the tool on the templet and move the tool with the templet guide sliding along the side of the templet.

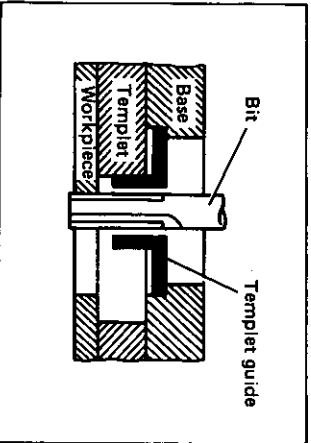

**Trimmer shoe (Optional accessory)**  
 By attaching the trimmer shoe you can obtain a right-angle guide surface for the trimmer base guide. This enables accurate chamfering and similar edge work.



Remove the trimmer guide from the tool. Install the trimmer shoe on the tool base with the adjusting screw and the clamp screw (B). Loosen the clamp screw (B) and adjust the distance between the bit and the trimmer shoe by turning the adjusting screw (1 mm or 3/64" per turn). At the desired distance, tighten the clamp screw (B) to secure the trimmer shoe in place. When cutting, feed the tool in the direction of the arrow on the trimmer shoe.

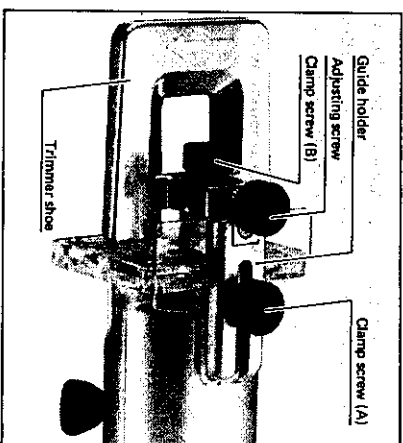

## MAINTENANCE

### CAUTION:

Always be sure that the tool is switched off and unplugged before attempting to perform inspection or maintenance.

### Replacing carbon brushes

Remove and check the carbon brushes regularly. Replace when they wear down to the limit mark. Keep the carbon brushes clean and free to slip in the holders. Both carbon brushes should be replaced at the same time. Use only identical carbon brushes.

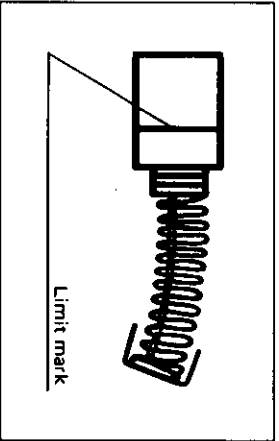

Use a screwdriver to remove the brush holder caps. Take out the worn carbon brushes, insert the new ones and secure the brush holder caps.

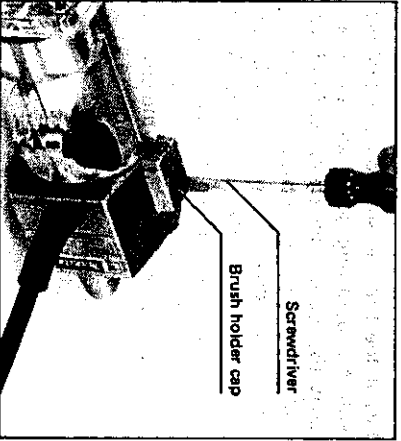

To maintain product **SAFETY** and **RELIABILITY**, repairs, any other maintenance or adjustment should be performed by Makita Authorized or Factory Service Centers, always using Makita replacement parts.

## ACCESSORIES

### CAUTION:

These accessories or attachments are recommended for use with your Makita tool specified in this manual. The use of any other accessories or attachments might present a risk of injury to persons. The accessories or attachments should be used only in the proper and intended manner.

### • Straight guide assembly Part No. 122391-0

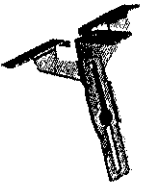

### • Trimmer base assembly

Part No. 122202-9 (Green color base)  
Part No. 122238-8 (Transparent base)



### • Trimmer guide assembly Part No. 132384-9



### • Trimmer shoe Part No. 155263-4



### • Template guide Part No. 343577-5



### • Sash router base assembly Part No. STEX 122201



### • Collet cone 6 mm Part No. 763607-0



### • Collet cone 1/4" Part No. 763608-8



### • Wrench 10 Part No. 781003-0



### • Wrench 17 Part No. 781008-0



**Bits**

**Straight bit**

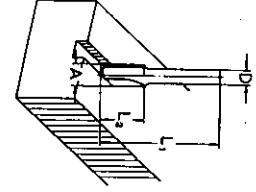

Part No.	D	A	L <sub>1</sub>	L <sub>2</sub>	L <sub>3</sub>	L <sub>4</sub>	R
793143.2	20	20	50	18	18	18	18
793160.3	20E	1/4	(25.02")	(1.3132")	(1.3132")	(1.3132")	(1.3132")
793077.9	8	8	50	18	18	18	18
793103.4	8	1/4	(5.078")	(1.3132")	(1.3132")	(1.3132")	(1.3132")
793078.1	6	6	50	18	18	18	18
793074.5	6E	1/4	(5.078")	(1.3132")	(1.3132")	(1.3132")	(1.3132")

**"U" Grooving bit**

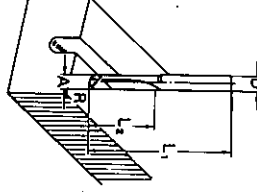

Part No.	D	A	L <sub>1</sub>	L <sub>2</sub>	L <sub>3</sub>	L <sub>4</sub>	R
793218.0	6	6	50	18	18	18	18
793218.8	6E	1/4	(5.078")	(1.3132")	(1.3132")	(1.3132")	(1.3132")

**"V" Grooving bit**

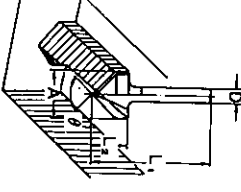

Part No.	D	A	L <sub>1</sub>	L <sub>2</sub>	L <sub>3</sub>	L <sub>4</sub>	R
793193.7	20	20	50	18	18	18	90°
793194.5	20E	1/4	(25.02")	(1.3132")	(1.3132")	(1.3132")	90°

**Drill point flush trimming bit**

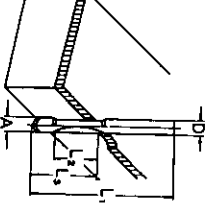

Part No.	D	A	L <sub>1</sub>	L <sub>2</sub>	L <sub>3</sub>	L <sub>4</sub>	R
793078.7	6	6	50	18	18	18	28
793104.4	6E	1/4	(5.078")	(1.3132")	(1.3132")	(1.3132")	28

**Drill point double flush trimming bit**

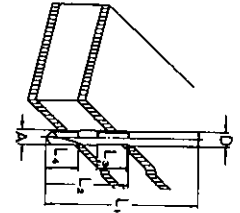

Part No.	D	A	L <sub>1</sub>	L <sub>2</sub>	L <sub>3</sub>	L <sub>4</sub>	R
793091.5	6	6	70	40	12	14	14
793111.9	6E	1/4	(5.078")	(2.364")	(1.3132")	(1.3132")	(1.3132")

**Corner rounding bit**

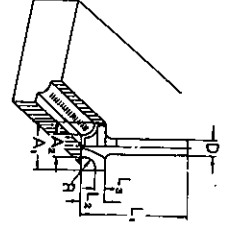

Part No.	D	A <sub>1</sub>	A <sub>2</sub>	L <sub>1</sub>	L <sub>2</sub>	L <sub>3</sub>	L <sub>4</sub>	R
793143.4	8R	25	8	48	12	5	8	8
793158.2	8RE	1/4	(6.350")	(2.364")	(1.5748")	(1.3132")	(1.3132")	(1.3132")
793081.8	4R	6	6	18	10	4	4	4
793105.0	4RE	1/4	(2.520")	(5.078")	(1.2538")	(1.3132")	(1.3132")	(1.3132")

**Chamfering bit**

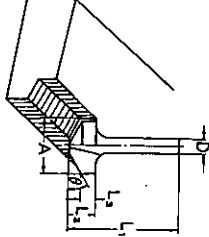

Part No.	D	A	L <sub>1</sub>	L <sub>2</sub>	L <sub>3</sub>	L <sub>4</sub>	R
793144.0	30°	23	48	11	6	6	30°
793161.0	30°E	1/4	(1.3132")	(0.7187")	(1.5649")	(1.5649")	30°
793040.0	45°	20	50	13	5	5	45°
793078.3	45°E	1/4	(25.02")	(1.3132")	(2.3649")	(1.3132")	45°
793145.8	60°	20	48	14	2	2	60°
793162.8	60°E	1/4	(25.02")	(1.3132")	(2.3649")	(1.3132")	60°

**Cove heading bit**

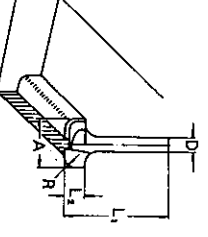

Part No.	D	A	L <sub>1</sub>	L <sub>2</sub>	L <sub>3</sub>	L <sub>4</sub>	R
793146.6	4R	20	48	6	6	6	4
793163.6	4RE	1/4	(25.02")	(1.3132")	(1.3132")	(1.3132")	(1.3132")
793147.4	8R	8	48	15	15	15	8
793164.4	8RE	1/4	(5.078")	(1.3132")	(2.3649")	(2.3649")	(1.3132")

**Ball bearing flush trimming bit**

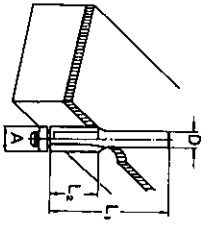

Part No.	D	A	L <sub>1</sub>	L <sub>2</sub>	L <sub>3</sub>	R
793144-2	10	10	50	20	20	3
793144-2	1/4	(25.04")	(1.31732")	(.8127")	(.8127")	(.0787")

**Ball bearing corner rounding bit**

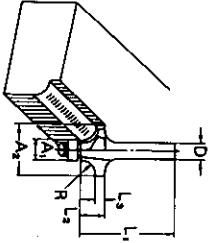

Part No.	D	A <sub>1</sub>	A <sub>2</sub>	L <sub>1</sub>	L <sub>2</sub>	L <sub>3</sub>	R
793151-3	1	15	8	37	7	3.5	3
793151-3	1/4	(3.8127")	(.618")	(1.1532")	(.9127")	(.884")	(.118")
793152-1	2	21	8	40	10	2.5	8
793152-1	1/4	(5.3044")	(.618")	(1.5704")	(2.5404")	(.635")	(.1584")

**Ball bearing chamfering bit**

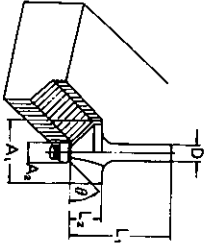

Part No.	D	A <sub>1</sub>	A <sub>2</sub>	L <sub>1</sub>	L <sub>2</sub>	L <sub>3</sub>	R
793148-0	45°	6	26	42	11	11	60°
793148-0	45°E	1/4	(3.175")	(1.7127")	(.8127")	(.8127")	(.45°)
793150-5	60°	6	20	41	11	11	60°
793150-5	60°E	1/4	(2.5404")	(.8127")	(.8127")	(.8127")	(.60°)

**Ball bearing beading bit**

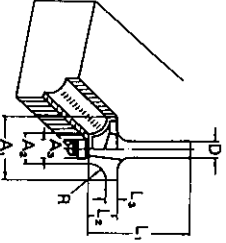

Part No.	D	A <sub>1</sub>	A <sub>2</sub>	L <sub>1</sub>	L <sub>2</sub>	L <sub>3</sub>	R
793153-8	2	20	12	40	10	5.5	4
793153-8	2E	1/4	(3.8127")	(.8127")	(1.3704")	(2.6404")	(.6327")
793170-9	3	26	12	42	12	4.5	7
793170-9	3E	1/4	(1.1232")	(.8127")	(1.5232")	(1.1794")	(.8327")

**Ball bearing cove beading bit**

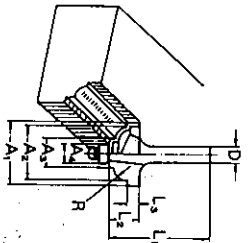

Part No.	D	A <sub>1</sub>	A <sub>2</sub>	A <sub>3</sub>	A <sub>4</sub>	L <sub>1</sub>	L <sub>2</sub>	L <sub>3</sub>	R
793157-1	2	20	18	12	8	40	10	5.5	3
793174-1	2E	1/4	(2.5404")	(.635")	(.8127")	(.8127")	(1.3704")	(2.6404")	(.7032")
793158-8	3	26	22	12	8	42	12	5	5
793175-9	3E	1/4	(1.1232")	(.762")	(.8127")	(.8127")	(1.5232")	(1.3284")	(.1584")

**Ball bearing roman ogee bit**

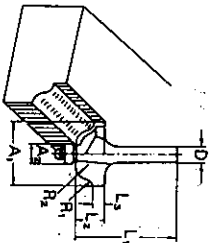

Part No.	D	A <sub>1</sub>	A <sub>2</sub>	A <sub>3</sub>	A <sub>4</sub>	L <sub>1</sub>	L <sub>2</sub>	L <sub>3</sub>	R <sub>1</sub>	R <sub>2</sub>
793155-5	2	20	8	40	10	4.5	4.5	4.5	2.5	4.5
793172-5	2E	1/4	(.618")	(1.3704")	(.8127")	(.8127")	(.8127")	(.8127")	(.1584")	(.8127")
793173-3	3	26	8	42	12	4.5	4.5	4.5	3	4.5
793173-3	3E	1/4	(1.1232")	(.618")	(1.3704")	(.8127")	(.8127")	(.8127")	(.1184")	(.8127")

**6 mm (1/4")  
TRIMMER  
Model 3701  
Model N3701**

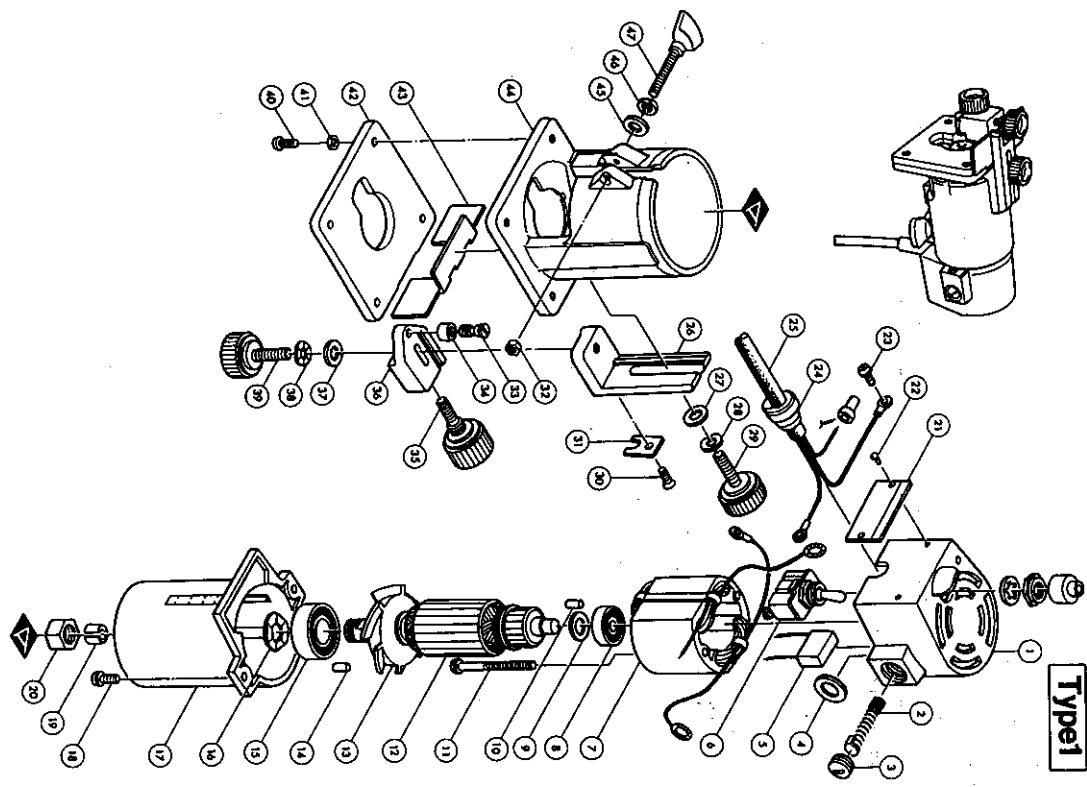

Note: The switch, noise suppressor and other part configurations may differ from country to country.

ITEM NO. USED	DESCRIPTION	ITEM NO. USED	DESCRIPTION
1	MOTOR REAR HOUSING	24	Cord Guard
2	Carbon Brush CR-50	25	Card
3	Brush Holder Cap	26	Guide Holder
4	Insulation Washer	27	Flat Washer 6
5	Noise Suppressor	28	Wave Washer 6
6	Switch	29	Screw M6x25
7	FIELD ASSEMBLY	30	Countersunk Head Screw M4x12 (With Washer)
8	Ball Bearing 627LB	31	Hook
9	Ball Bearing 627LB	32	Hex. Nut M5
10	Flat Washer 7	33	Flat Head Screw M5
11	Rubber Pin 4	34	Roller 11
12	ARMATURE ASSEMBLY	35	Screw M6
13	(With Item 8, 9, 12, 13 & 15)	36	Trimmer Guide
14	Fan 52	37	Flat Washer 6
15	Rubber Pin 6	38	Wave Washer 6
16	Ball Bearing 6002DDW	39	Screw M5x25
17	Wave Washer 23	40	Flat Head Screw M4x10
18	Motor Housing	41	Flat Washer 4
19	Pen Head Screw M4x12 (With Washer)	42	Base Protector
20	Collar Nut 6	43	Chip Deflector
21	Hexa Plate	44	Base
22	Pinet 0-5	45	Flat Washer 5
23	Pen Head Screw M4x8 (With Washer)	46	Spring Washer 5
24	Cord Guard	47	Screw M5x30

Note: The switch, noise suppressor and other part specifications may differ from country to country.