



RISK CONTROL MANAGEMENT PROCEDURE

2. Risk Control

Consequence	Probability	
	L	UL
S	High	Medium
M	Medium	Low

Implementation of Risk Control:

Where a risk to health and safety has been identified utilizing the Risk Severity Table, controls to eliminate or minimise the risk are required.

The control is to be selected from the following hierarchy of controls:

- Level 1 Eliminate the hazard
- Level 2 Minimise the risk from the hazard
If the hazard cannot be eliminated, the machine should be constructed to minimise the risk *as far as practicable*
- Level 3 Provide back up controls
Provided levels 1 & 2 have been exhausted, back up controls include administrative controls governing work practices (eg operator's manual safe working instructions) and personal protective equipment.

Risk Control Table

RISK	CONTROL MEASURE (how/who/time frame)	Implementation date	Review date
Entanglement in tracks	SOP in manual, Safety Decals, Travel Alarm, Operating Clearance Zone	2/7/2006	On Going
Machine Roll Over	Certifies ROPS/FOPS, SOP	2/7/2006	On Going
Crushing by boom or tracks	SOP, safety decals, Operating Clearance Zone, Travel Alarm and horn	2/7/2006	On Going
Shearing from blade	SOP, Safety Decals, Operating Clearance Zone	2/7/2006	On Going
Striking by Boom or Machine	Boom Swivel Pedal Lockout, Operator control locks, horn	2/7/2006	On Going
Electrocution	SOP, Decals, "Dial before you gig, "Look up and live"	2/7/2006	On Going
Slipping/tripping from Mounting/Dismounting	Hand Rail, Non slip Mat	2/7/2006	On Going
Engine Noise	Complies to current regulations	2/7/2006	On Going
Eye damages from dust/debris	PPE, SOP	2/7/2006	On Going

KTA OHS HRA Form 001 Version Oct 2005

3. Review

The above Risk Assessment to be reviewed during the life of the product if an upgraded model is introduced or information is obtained about a previously unknown hazard.



104 Wetherill Street Silverwater NSW 2128 P.O. Box 6466 Silverwater NSW 2128

Ph:(02) 9748 1999 Fax:(02) 9748 2414

Emails: sales@australianhammer.com.au

www.australianhammer.com.au

Australian Hammer Supplies Pty Ltd ABN 35 050 106 431 KubFORCE Pty Ltd ABN 46 896 048 429

sales@kubforce.com.au

www.kubforce.com.au



RISK CONTROL MANAGEMENT PROCEDURE

Product Description Excavator Series Kubota
 Model KX41-3 Serial No. 3188
 Attachment/s 1/2 Hitch, 300, 450 # Revision _____
m Buckets Date 26-9-2006
 Date of Inspection 26-9-2006 Location Silverwater
 Inspected by David Sellon Title Sales Rep
 Signature

Select unit type with a tick

SAMPLE UNIT

PRODUCTION UNIT

Select risk type with a tick

OPERATIONAL

MAINTENANCE

1. Hazard Analysis and Risk Assessment

HAZARD	RISK SOURCE	SAFETY MEASURE	OCCURANCE	
			Probability	Consequence
Entanglement	Tracks	SOR Decals, Travel Alarm, Operating Clearance Zone	UL	S
Crushing	Roll over, boom & tracks	Certified ROPS/FOPS and seatbelt, SOR Decals, Operating Clearance Zone, Travel Alarm & horn.	UL	S
Cutting/Stabbing/Puncturing				
Shearing	Blade (bystanders)	SOR Decals, Operating Clearance Zone	UL	S
Friction				
Striking	Boom, Machine, Twin pattern selection system	Boom swivel pedal lockout, Operator control, locks, horns, decals	UL	S
Electrical	Overhead/underground power	SOR Decals, Dial before you dig, "Look up and Live"	UL	S
Slipping/Tripping/Falling	Mount/Dismount	Hand Rail, Non Slip Mat	L	M
Noise	Engine	Within regulation sound level	L	M
Manual Handling				
Other Hazards	Dust/debris	PPE	L	M

KTA OHS HRA Form D01 Version Oct 2005

Probability Scale
 L = likely
 UL = Unlikely

Consequence Scale
 S = major injury/fatality
 M = minor injury



104 Wetherill Street Silverwater NSW 2128 P.O. Box 6466 Silverwater NSW 2128
 Ph: (02) 9748 1999 Fax: (02) 9748 2414

Emails: sales@australianhammer.com.au
 www.australianhammer.com.au

sales@kubforce.com.au
 www.kubforce.com.au

Australian Hammer Supplies Pty Ltd ABN 35 050 106 431 KubFORCE Pty Ltd ABN 46 896 046 429

OPERATOR'S MANUAL

KUBOTA EXCAVATOR

MODELE

KX 41-3

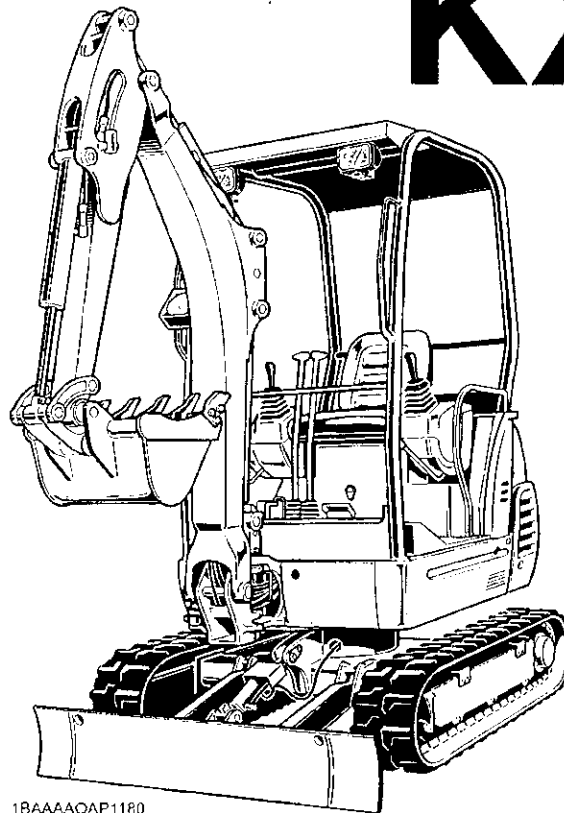

1BAAAAQAP1180

READ AND SAVE THIS MANUAL

Kubota

LIST OF ABBREVIATION

Abbreviations	Description
API	American Petroleum Institute
ASTM	American Society for Testing and Materials, USA
CECE	Committee for European Construction Equipment
DIN	German Institute for Standards, Federal Republic of Germany
EN	European Standard
FOPS	Falling Object Protective Structures
FRONT	"Front" means the front view towards the boom and dozer
Hi	High speed
ISO	International Standardization Organization
JIS	Japanese Industrial Standard
L	Volume (Liter)
L/min	Liter per minute
Lo	Low speed
MIL	Military Standards
rpm	Revolutions per minute
ROPS	Roll-Over Protective Structures
SAE	Society of Automotive Engineers, USA
TPSS	Two Pattern Selection System
AI	Auto Idle



































California Proposition 65

WARNING

The engine exhaust from this product contains chemicals known to the State of California to cause cancer, birth defects or other reproductive harm.

GENERAL SYMBOLS

The instruments and operation elements have been marked with a series of symbols in order to simplify the operation of your excavator. These symbols are listed below with the respective descriptions.

 Safety alert Symbol	 Boom swing (left)
 Warning lamp "Fuel level too low"	 Boom swing (Right)
 System lamp	 Dozer raise
 Warning lamp "Engine Oil pressure "	 Dozer lower
 Warning lamp "Battery charge"	 Operation direction of control lever
 Warning lamp "Auto Idle (AI) Lamp"	 Operation direction of control lever
 Indicator lamp "Glow"	 Read operator's manual
 Working light switch	 Engine stop control lamp
 Horn	 Lock
 Wiper/Washer switch	 Unlock
 Diesel	 Reducing / Increasing track width
 Hydraulic fluid	
 Gear oil	
 Grease	
 Fast	
 Slow	
 Excavator - Overhead movement toward the front	
 Excavator - Overhead movement toward the rear	
 Boom up	
 Boom down	
 Arm up	
 Arm crowd	
 Bucket crowd	
 Bucket dump	

FOREWORD

You are now the proud owner of a KUBOTA excavator. This excavator is a product of KUBOTA quality engineering and manufacturing. It is made of the fine materials and under rigid quality control systems. It will give you long, satisfactory service. To obtain the best use of your excavator, please read this manual carefully. It will help you become familiar with the operation of the excavator and contains many helpful hints about excavator maintenance. It is KUBOTA's policy to utilize as quick as possible every advance in our research. The immediate use of new techniques in the manufacture of products may cause some small parts of this manual to be outdated. KUBOTA distributors and dealers will have the most up-to-date information. Please do not hesitate to consult with them.

Please note that there may be some differences between your actual machine and the illustrations in the instructions.



SAFETY FIRST

This symbol, the industry's "Safety Alert Symbol", is used throughout this manual and on labels on the machine itself to warn of the possibility of personal injury. Read these instructions carefully. It is essential that you read the instructions and safety regulations before you attempt to assemble or use this unit.

**DANGER :**

Indicates an imminently hazardous situation which, if not avoided, will result in death or serious injury.

**WARNING :**

Indicates a potentially hazardous situation which, if not avoided, could result in death or serious injury.

**CAUTION :**

Indicates a potentially hazardous situation which, if not avoided, may result in minor or moderate injury.

IMPORTANT :

Indicates that equipment or property damage could result if instructions are not followed.

NOTE :

Gives helpful information.

CONTENTS

▲ SAFE OPERATION	1
DEALER SERVICE	1
TECHNICAL DATA	2
DESCRIPTION OF MACHINE PARTS	3
INSTRUMENT PANEL AND CONTROL ELEMENTS	4
CHECKS BEFORE START	6
DAILY CHECKS	6
OPERATION OF THE ENGINE	7
STARTING THE ENGINE	7
Display Selector Switch	8
Charge Lamp	8
Oil Lamp	8
Glow Lamp	8
LCD Display for Normal Operation	9
LCD Display for Warning	10
Warning Lamp	10
Checkpoints after Starting the Engine	11
STARTING THE ENGINE UNDER COLD CONDITIONS	11
Precautions in case of Overheat	12
STOPPING THE ENGINE	12
Emergency Engine Stop Fuse	12
STARTING WITH AN AUXILIARY BATTERY	13
Observe Following Guidelines when Starting with an Auxiliary Battery	13
EXCAVATOR OPERATION	14
RUNNING-IN OF THE NEW EXCAVATOR	14
Do not Work with Full Engine Rpm's or Full Loads during the First 50 Working Hours ..	14
Oil Change in the Run-in Stage	14
Seat Belt	14
STARTING	14
Operator's Seat	14
Operator's Seat for Australia	15
Lock Lever	15
Working Light Switch	16
Travel Buzzer (Option)	16
OPERATION OF TRACK WIDTH CHANGE AND DOZER	16
Adjustment of the Dozer Width	17
DRIVING	18
Drive Levers(Right,Left)	19
Travel Speed Switch	19
TURNS	20
Pivot Turn	20
Spin Turn	21
UP AND DOWNHILL DRIVING	22

CONTENTS

OPERATION OF THE DOZER	2
TWO PATTERN SELECTION SYSTEM(TPSS)	2
Pattern Change.....	2
OPERATION OF THE BOOM.....	2
OPERATION OF THE ARM.....	2
OPERATION OF THE BUCKET	2
UNIT SWING AND BOOM SWING OPERATION.....	2
Unit Swing Operation.....	2
Boom Swing Operation.....	2
SERVICE PORT OPERATION	2
IMPORTANT INFORMATION ON EXCAVATOR OPERATION.....	2
TRANSPORTING THE EXCAVATOR ON A VEHICLE.....	2
LIFTING OF THE EXCAVATOR.....	3
MAINTENANCE.....	3
MAINTENANCE INTERVALS	3
OPENING AND CLOSING OF PARTS.....	3
Opening and Closing of the Fuel Tank Cap.....	3
Opening/Closing of the Engine Hood	3
Where to store the Grease Gun.....	3
Where to keep Operator's Manual.....	3
DAILY CHECKS.....	3
Checking Coolant Level.....	3
Checking Fuel Level	3
Checking Engine Oil Level.....	3
Checking Hydraulic Oil Level.....	3
Lubrication Points	3
Checking Radiator and Oil Cooler	3
Checking and Cleaning Engine and Electrical Wiring.....	3
Washing Whole Machine	3
REGULAR CHECKS AND MAINTENANCE WORK	4
EVERY 50 SERVICE HOURS	4
Draining Fuel Tank	4
Draining Fuel Filter	4
Battery	4
Battery Charging.....	4
Greasing Swing Bearing Teeth.....	4
EVERY 200 SERVICE HOURS	4
Checking Fan Belt Tension.....	4
Checking Radiator Hoses and Clamps.....	4
Inspection and Cleaning Air Filter Element.....	4
Air Filter Maintenance.....	4
Greasing Swing Bearing.....	4
Checking Fuel Line and Intake Air Line	4
EVERY 250 SERVICE HOURS	4
Changing Engine Oil(First Engine Oil Change after 50 Service Hours)	4
Replacing Engine Oil Filter	4
EVERY 500 SERVICE HOURS	4
Drive unit Oil Change(First Oil Change at 100 hours)	4
Replacing Fuel Filter Element.....	4

Replacing Hydraulic Return Filter Element(first replacement after 250 service hours) ..	46
EVERY 1000 SERVICE HOURS	46
Hydraulic Oil Check for Machines with Hydraulic Breakers	46
Hydraulic Oil Change(Including Replacing Suction Filter in Hydraulic Tank)	47
EVERY 1000 SERVICE HOURS OR ONCE A YEAR	47
Replacing Air Filter Element	47
EVERY 1500 SERVICE HOURS	48
Checking Fuel Injection Nozzle(Injection Pressure)	48
EVERY 2000 SERVICE HOURS	48
Changing Front Idler and Track Roller Oil	48
Checking Alternator and Starter Motor	48
EVERY 3000 SERVICE HOURS	48
Checking Injection Pump	48
ANNUAL SERVICE	48
Electrical Wiring and Fuses	48
BIENNIAL SERVICING	48
Replacing of Radiator Hoses	48
Changing Radiator Coolant	48
Replacing Fuel Hose	49
Replacing Intake Air line	49
OTHER ADJUSTMENTS AND REPLACEMENTS	50
PURGING FUEL SYSTEM	50
ADJUSTMENT OF TRACKS	50
Rubber Tracks	50
Special Information when Using Rubber Tracks	51
FUSES	52
Replacing Fuses	52
Fuse Capacities and Circuits	52
Auxiliary Electric	52
Slow Blow Fuse	52
TROUBLESHOOTING	53
KUBOTA I.C.S. NAVIGATION LIST OF MESSAGES	55
OPERATION UNDER COLD WEATHER CONDITIONS	57
PREPARATION FOR OPERATION IN COLD WEATHER	57
PROCEDURE AFTER DONE WORK	57
LONG STORAGE	58
RECOMMENDED OILS	60
APPENDICES	61
MAIN DIMENSIONS	61
LIFTING CAPACITY	62



SAFE OPERATION

The best insurance against accidents is to abide by the safety regulations.

Read and understand this manual carefully before operating the excavator.

Every user, however experienced, should carefully read and understand this manual and those of the attachments and accessories before taking the excavator into operation. The owner is obliged to inform the operators of these instructions in detail.

Keep this manual in the pocket under the seat.

1. BEFORE OPERATION

1. Make yourself acquainted with the excavator and be aware of its limits. Read the operating instructions carefully before starting the excavator.
2. Obey the danger, warning and caution labels on the machine.
3. For your safety, ROPS/FOPS (Roll-Over Protective Structures, Falling Objects Protective Structures.) with a seat belt is installed by KUBOTA. Always use the seat belt when the machine is equipped with a ROPS/FOPS.
Do not modify structural members of ROPS by welding, drilling, bending, grinding or cutting, as this may weaken the structure. If any component is damaged, replace it. Do not attempt repairs. If ROPS is loosened or removed for any reason, make sure all parts are reinstalled correctly. Tighten mounting bolts to proper torque.
4. The seat belt must be inspected regularly and replaced if damaged.

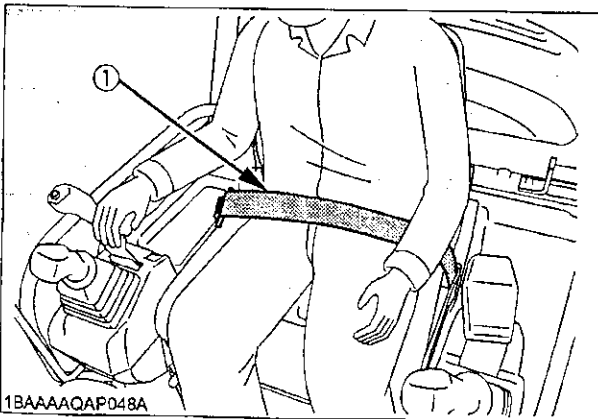

1BAAAQAP048A

(1) Seat belt

5. Always sit in the operator's seat when starting engine or operating levers or controls.

6. Study control lever pattern A and pattern B. Then choose the one which is most familiar. Familiarize yourself with the pattern selected by operation slowly at low engine speed.

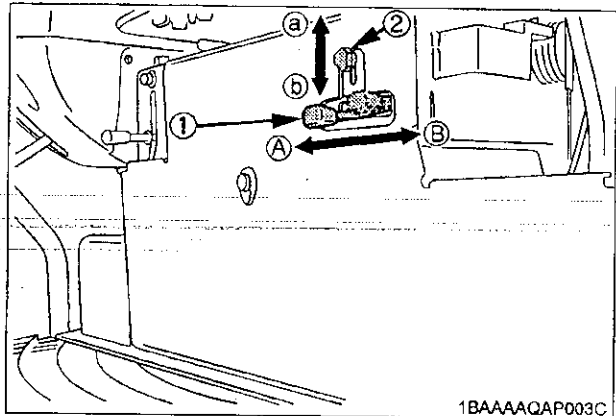

1BAAAQAP003C

- (1) Pattern selector lever
(Two Pattern Selection System:TPSS)
(2) Lever lock Knob
- (a) "UNLOCK"
(b) "LOCK"

7. Do not operate the excavator while under the influence of alcohol, medication, controlled substances or while fatigued.
8. Track can be set at the narrow width 990 mm (39.0 in.) and the standard width 1300 mm (51.2 in.).
(for details see "OPERATION OF TRACK WIDTH CHANGE AND DOZER")
Operate always in standard track width 1300 mm (51.2 in.), except to pass through narrow space.
Do not operate in narrow track width 990 mm (39.0 in.), it makes risk of the excavator tipping over.

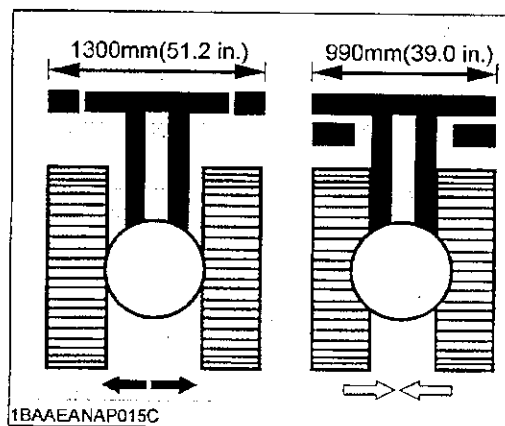

1BAAEANAP015C

8. When parking your machine, if at all possible, park on a firm, flat and level surface; if not, park across a slope. Lower the bucket and dozer to the ground, remove the key place the control lock levers in the locked position from the ignition and lock the cab door (if equipped), before you leave.

3. AFTER OPERATION

Before leaving the machine,

- Park the excavator on a firm, flat and level surface.
- Lower the attachments and the dozer blade to the ground.
- Stop the engine.
- Lock all control levers.
- Remove the key.

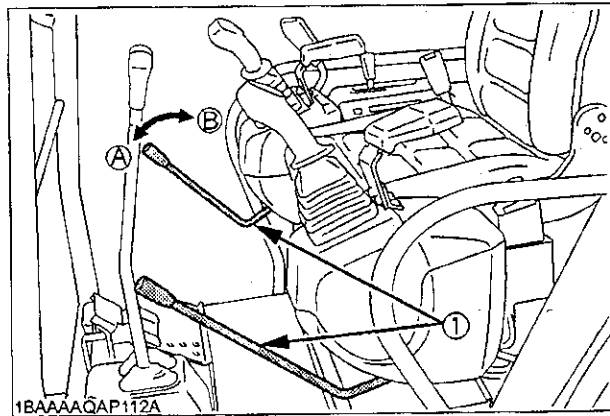
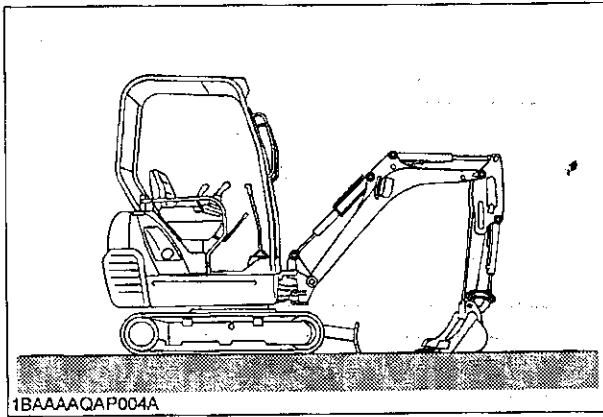

(1) Lock lever for control lever (A) "Unlock" (B) "Lock"

4. SAFE LOADING AND TRANSPORT OF THE EXCAVATOR

1. Observe all regulations concerning the transport of excavators on public roads.
2. Use adequately long and robust ramps when loading on the machine. (for details see "TRANSPORTING THE EXCAVATOR ON A VEHICLE")
3. Do not change the running direction and to avoid a tipping over, do not try to swing the attachment crosswise to the loading ramps.
4. After loading of the excavator on a truck, engage the swing lock pin. Lower the attachment on the loading bed and release the pressure from the hydraulic system. After loading the excavator on the truck, block the tracks with blocks and cable down the excavator.

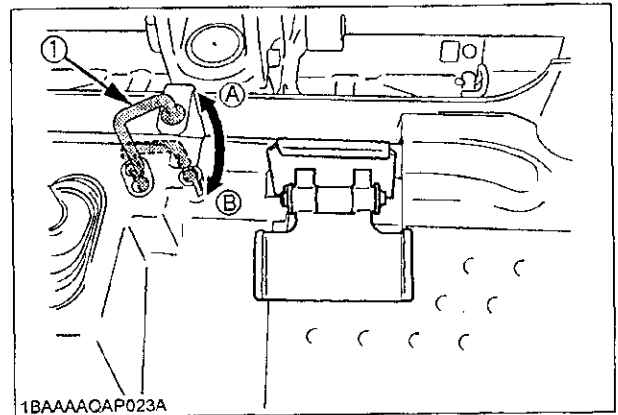

(1) Swing lock pin (A) "Unlock" (B) "Lock"

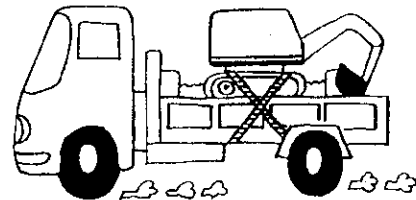

5. Avoid abrupt braking of the vehicle with the excavator loaded. Sudden braking cause the excavator to move and may cause a serious accident.
6. If the excavator is to tow another machine, make sure the load is smaller than the strength of the hook, tow chain or cable.

Max. drawbar pull at coupling hook	70450 N (15838 lbf, 7184 kgf)
Max. vertical load at coupling hook	7210 N (1621 lbf, 735 kgf)

7. Do not use hooks on the roof of canopy or CAB for lifting the excavator.

5. MAINTENANCE

Before doing maintenance work on the excavator, place the machine on even solid ground, lower the attachments to the ground, stop the engine and remove the key. When dismantling hydraulic parts, make sure that the hydraulic oil has cooled down sufficiently to avoid burns.

Start maintenance work carefully, e.g. loosen plug slowly so that oil will not squirt out.

1. Before doing work on the engine, the exhaust system, the radiator and the hydraulics, let the excavator cool down sufficiently.
2. Turn off the engine at all times when filling with fuel. Avoid spilling and over-filling of fuel.
3. Smoking is prohibited while refueling or handling the battery! Keep sparks and fire away from the fuel tank and battery. Flammable gases escape from the battery, especially during charging.
4. Do not use or charge the refillable type battery if the fluid level is below the LOWER (lower limit level) mark. Otherwise, the battery component parts may be prematurely deteriorated, which may shorten the battery's service life or cause an explosion. Check the fluid level regularly and add distilled water as required so that the fluid level is between the UPPER and LOWER levels.
5. Read and follow the directions "STARTING WITH AN AUXILIARY BATTERY" in "OPERATION OF THE ENGINE", when starting with an auxiliary battery.
6. Keep a first-aid box and a fire extinguisher at hand at all times.
7. Do not open the radiator cap before the radiator has cooled down sufficiently
First loosen the cap to the first stop and allow the system enough time to release the remaining pressure. Then loosen the cap completely.
8. To avoid short-circuiting the battery, always remove the ground cable first and attach the plus cable first.
9. Leaking hydraulic fluid has enough pressure to penetrate the skin and cause serious injuries. Leakages from pin holes can be totally invisible. Do not use hands for checking for leaks. Always use a piece of wood or cardboard. It is strongly recommended to use a face mask or eye protection. Should injuries occur with leaking hydraulic fluid, contact a doctor immediately. This fluid can cause gangrene or serious allergic reactions.

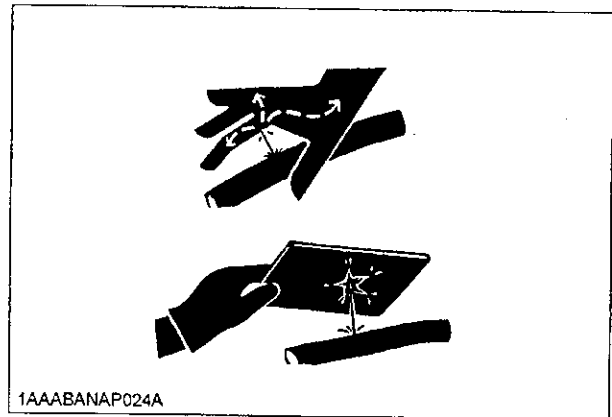

1AAABANAP024A

10. To avoid environmental damage from acid and heavy metals, do not throw the battery away.
11. Observe all laws and regulations concerning the disposal of used oil, coolants, solvents, hydraulic fluids, battery acids and batteries.
12. To avoid fire, do not heat the hydraulic components (tanks, pipes, hoses, cylinders) before they have been drained and washed.
13. Use a face mask or eye protection to protect the eyes and respiratory system against dust and other foreign particles.

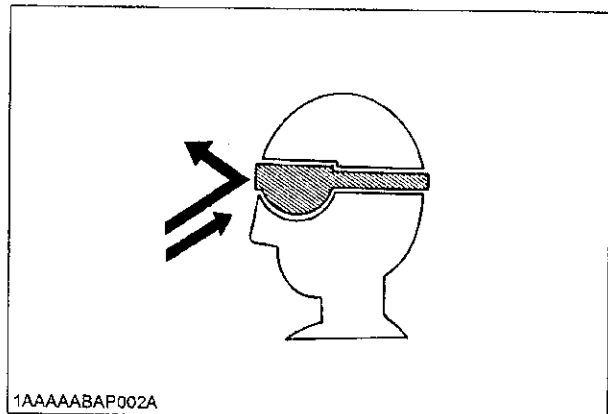

1AAAAABAP002A

14. Securely support excavator with stands or suitable blocking before working underneath. For your safety, do not work under any hydraulically supported devices. They can settle, suddenly leak down, or be accidentally lowered.
15. Do not dismantle the spring of the track tensioner. If dismantling is necessary, contact your KUBOTA dealer where the machine was purchased, or competent service shop. The assembly must be done according to the work shop manual of KUBOTA (W.S.M.) for the product involved.

6 SAFE OPERATION

16. When lifting the machine itself with an attachment, place a safety block or safety post to prevent the machine from turning over. Keep the lock lever for attachment control in the "LOCK" position.

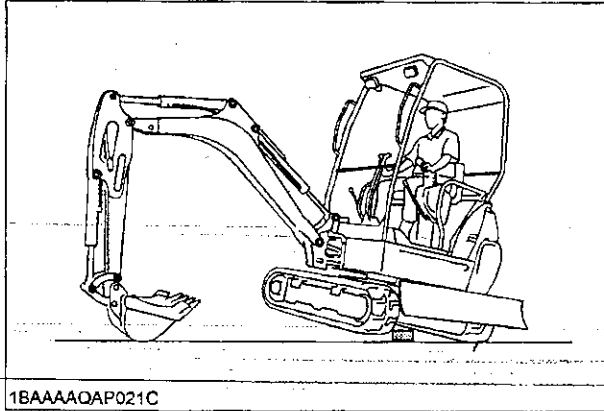

1BAAAAQAP021C

17. KUBOTA uses no parts which are lined with asbestos. Do not use these kind of parts even if they are available and can be installed.

6. DANGER, WARNING AND CAUTION LABELS

(1) Code No. RC418-5728-4

CAUTION	TO AVOID PERSONAL INJURY:
	<ol style="list-style-type: none"> 1. Read and understand operator's manual before attempting to start or operate the excavator. 2. Before starting engine, make sure all control levers are in neutral and the operating area is clear of all bystanders. 3. Never allow passengers on any part of the excavator while operating. 4. Know your work area before starting operation. <ul style="list-style-type: none"> ● Check underground pipes and cables. ● Stay off slopes and steep for safe operation. ● Check overhead clearance with electric wires. ● Check for hidden holes, obstacles, or low drift. 5. Make sure all shields are in place and securely fastened. 6. Before dismounting from the machine, lower all attachments to the ground, stop the engine and remove the key. 7. Damaged ROPS must be replaced, not repaired or rewired. <p>Never use boom, dipper, or bucket to hammer or beat sideways. Excavator is not intended for these uses.</p>
IMPORTANT	

1BAAAAQAP0780

(2) Code No. RC418-5727-4

	A WARNING
<p>TO AVOID PERSONAL INJURY OR DEATH: Before moving the excavator, KNOW THE LOCATION OF THE DOZER BLADE. The excavator will travel in the direction of the dozer blade when drive levers are moved away from the operator.</p>	<p>DO NOT OPERATE WITHOUT ROPS. YOU COULD BE CRUSHED.</p> <p>USE SEAT BELT</p>

1BAAAAQAP0790

(3) Code No. RC418-5733-2

DANGER
<p>TO AVOID SERIOUS INJURY OR DEATH: Check overhead clearance with electric wires.</p>

1BAAAAQAP0800

(4) Code No. RD517-5795-1 [Both sides]

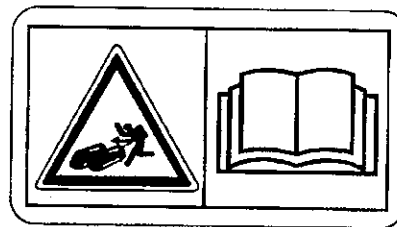

1BAABAMAP0010

(5) Code No. RB419-5796-1 [Both sides]

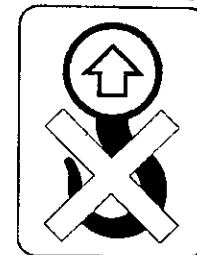

1BAABAUAP2720

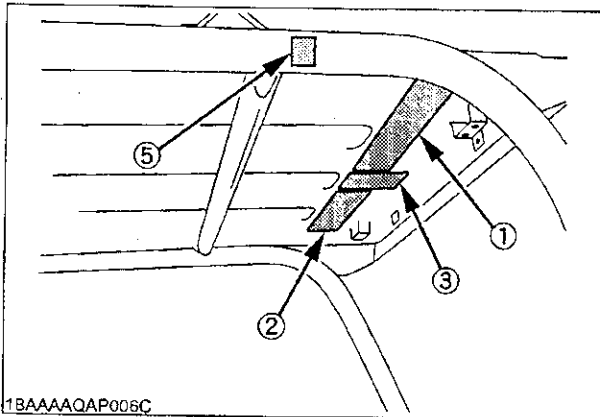

1BAAAAQAP008C

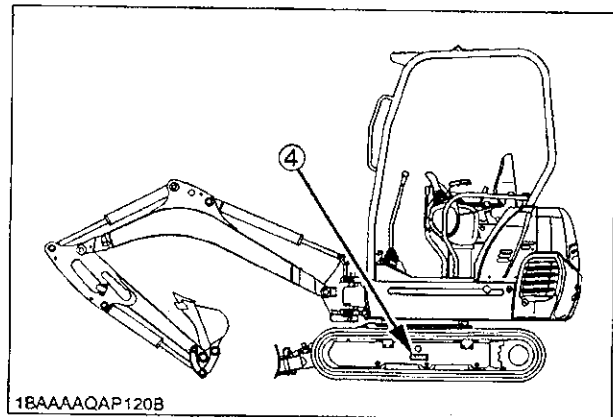

1BAAAAQAP120B

(1) Code No. RB208-5762-1

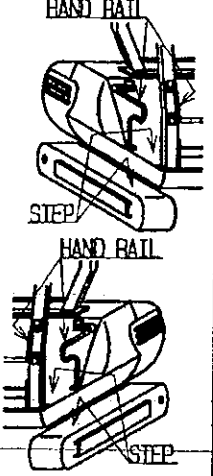

CAUTION

TO AVOID PERSONAL INJURY:
Mount and dismount safely when entering or leaving the operator's compartment.

1. Maintain a three point contact with the steps and handrails.
2. Face the machine.
3. Never jump on or off the machine.
4. Never attempt to mount or dismount a moving machine.
5. Never use control levers as handles.

1BAAAAQAP0810

(2) Code No. RB238-5732-1



CAUTION

TO AVOID PERSONAL INJURY:

1. Study control lever pattern A and pattern B. Then choose the one which is most familiar.
2. Position the pattern selector lever in either the left position (pattern A) or the right position (pattern B).
3. Engage lever lock to prevent accidental pattern change.
4. Familiarize yourself with the pattern selected by operating slowly.

1BAAAAQAP0820

(3) Code No. RC418-5753-1

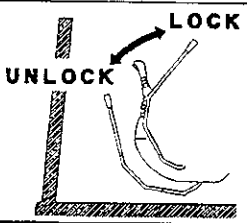

CAUTION

TO AVOID PERSONAL INJURY:
Lock control lever before leaving compartment.

1BAAAAQAP0830

(4) Code No. R2401-5736-1

Diesel fuel only No fire

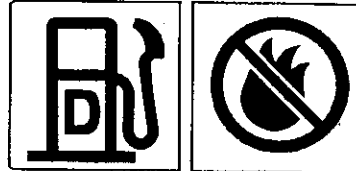

1BAAAAQAP0840

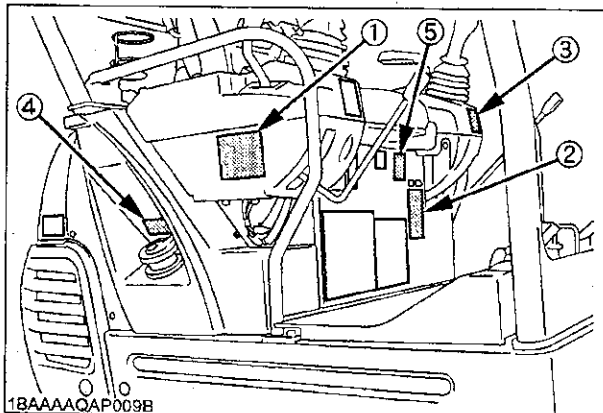

1BAAAAQAP009B

(5) Code No. RB238-5753-1



CAUTION

TO AVOID PERSONAL INJURY:
The Knob must be tightened at Lock position except TPSS pattern selected.

1BAAAAQAP0850

(1) Code No. TA040-4958-1
Do not touch hot parts such as exhaust etc.



1BAAAAQAP0860

(2) Code No. RB238-5754-1



1BAAAAQAP0870

(3) Code No. RC418-5737-2
Keep away from fan and fan belt.



1BAAAAQAP0880

(4) Code No. RC108-5754-1



1BAAAAQAP0890

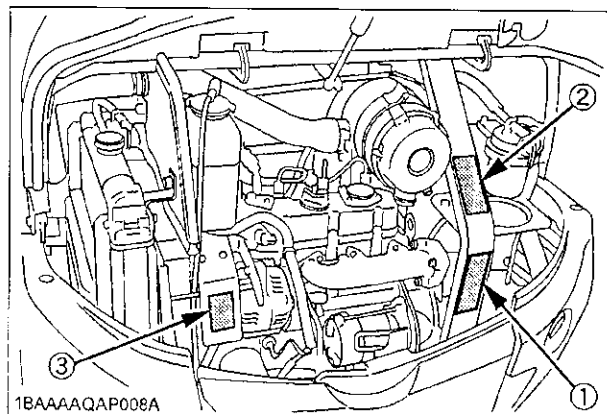

1BAAAAQAP008A

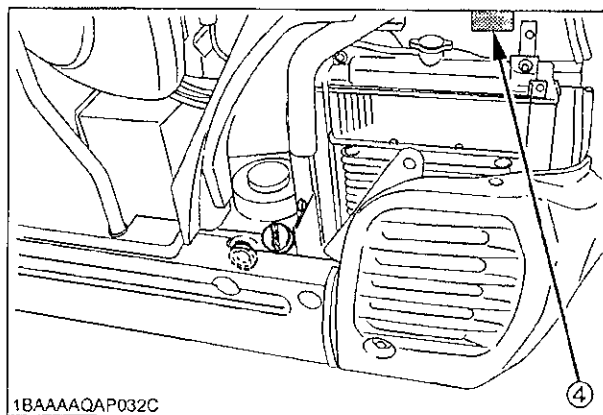

1BAAAAQAP032C

- (1) Code No. RA028-5728-1
Do not allow any persons within the working range.



1BAAAAQAP0900

- (2) Code No. RC108-5718-1

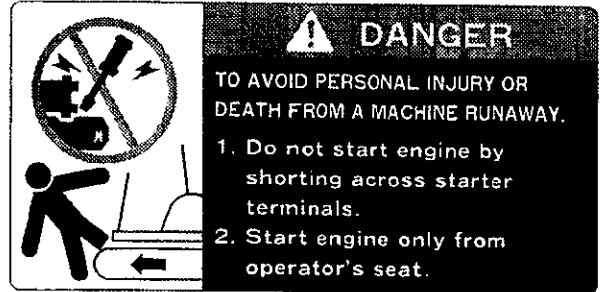

1BAAAAQAP0910

- (3) Code No. RB238-5737-1

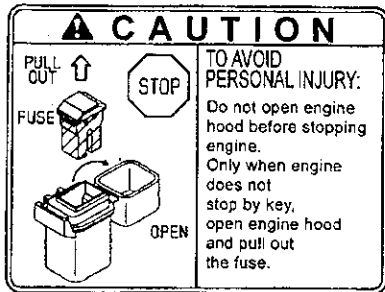

1BAAAAQAP0920

- (4) Code No. 68328-5735-1 [Both sides]

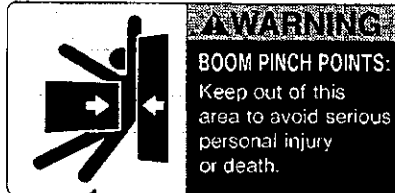

1BAAAAQAP0930

- (5) Code No. RC108-5796-1 [Both sides]

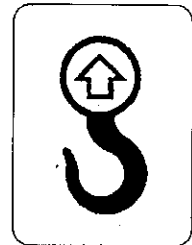

1BAAAAQAP0940

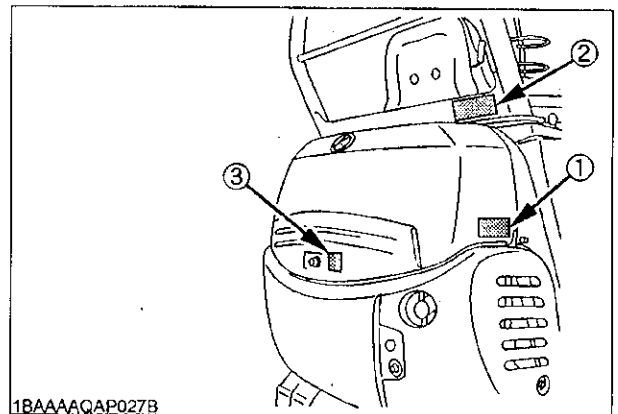

1BAAAAQAP027B

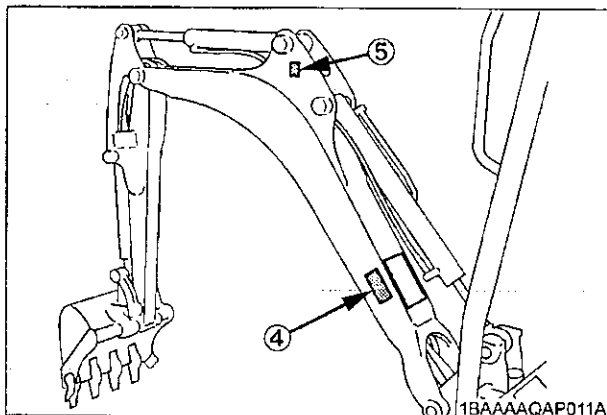

1BAAAAQAP011A

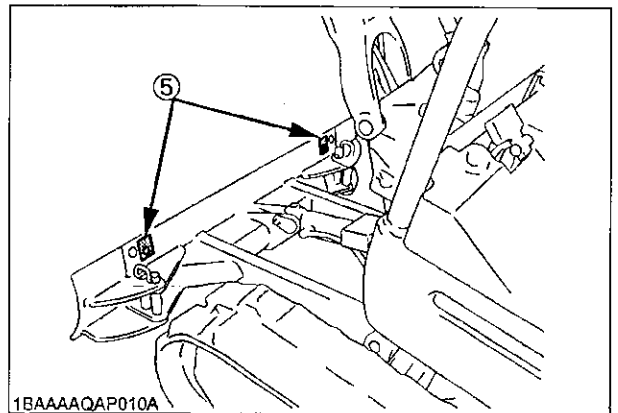

1BAAAAQAP010A

(1) Code No. RB238-5747-2

WARNING
TO AVOID PERSONAL INJURY OR DEATH.

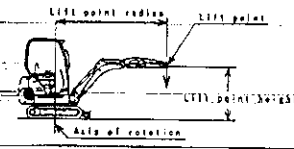

- The lifting capacities are based on ISO 10567 and do not exceed 75% of the static lift load of the machine or 87% of the hydraulic lifting capacity of the machine.
- The strokes are as follows:
 - The load point corresponds to the front bolt part of the arm.
 - The machine positions are (I) over-front (Blade up), and (II) over-side.
 - The operating cylinder is the boom cylinder.
- The bucket of the excavator, the hook, the sling and other lifting accessories are taken into consideration for the loads.

LIFT POINT HEIGHT (ft.)	LIFTING CAPACITY OVER-FRONT BLADE DOWN			LIFTING CAPACITY OVER-FRONT BLADE UP			LIFTING CAPACITY OVER-SIDE TRACK WIDTH 1900mm			LIFTING CAPACITY OVER-SIDE TRACK WIDTH 1900mm		
	LIFT POINT RADIUS (ft.)			LIFT POINT RADIUS (ft.)			LIFT POINT RADIUS (ft.)			LIFT POINT RADIUS (ft.)		
	MIN	0	MAX	MIN	0	MAX	MIN	0	MAX	MIN	0	MAX
1		0.69			0.69			0.69			0.48	
2		0.69	0.75		0.69	0.47		0.69	0.51		0.48	0.53
4	0.97	0.82	0.70	0.97	0.66	0.49	0.97	0.71	0.51	0.77	0.48	0.52
6	1.65	0.81	0.62	0.95	0.64	0.45	1.05	0.59	0.50	0.69	0.44	0.52
8	1.95	1.13	0.60	0.82	0.62	0.45	1.02	0.57	0.49	0.63	0.43	0.51
10	1.84	1.56	0.59	0.84	0.59	0.61	0.44	1.24	1.01	0.58	0.49	0.51
12	1.87	1.55	0.49	1.27	0.55	0.62		2.01	1.02	0.57	1.16	0.42

Machine with ROPS canopy and rubber crawler, without bucket

(2) Code No. 6C040-5559-1

DANGER EXPLOSIVE GASES
 Cigarettes, flames or sparks could cause battery to explode. Always shield eyes and face from battery. Do not charge or use booster cables or adjust post connections without proper instruction and training.
KEEP VENT CAPS TIGHT AND LEVEL
POISON CAUSES SEVERE BURNS
 Contains sulfuric acid. Avoid contact with skin, eyes or clothing. In event of accident flush with water and call a physician immediately.
KEEP OUT OF REACH OF CHILDREN

1BAAAAQAP0960

1BAAAAQAP0950

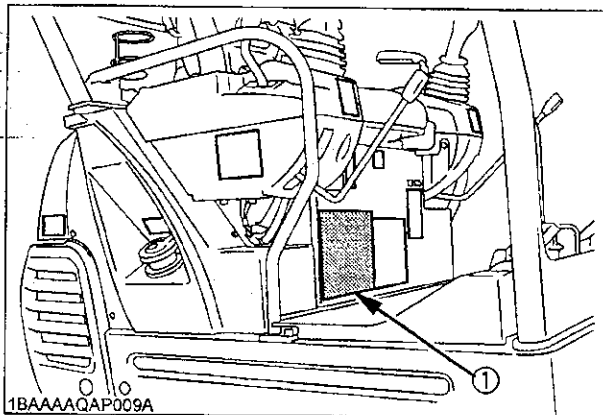

1BAAAAQAP009A

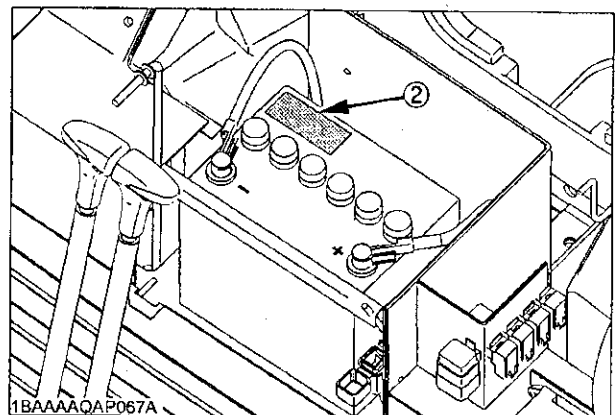

1BAAAAQAP067A

7. CARE OF DANGER, WARNING AND CAUTION LABELS

1. Keep danger, warning and caution labels, clean and free from obstructing material.
2. Clean danger, warning and caution labels with soap and water, dry with a soft cloth.
3. Replace damaged or missing danger, warning and caution labels with new labels from your KUBOTA dealer.
4. If a component with danger, warning and caution label(s) affixed is replaced with new part, make sure new label(s) is (are) attached in the same location(s) as the replaced component.
5. Mount new danger, warning and caution labels by applying on a clean dry surface and pressing any bubbles to outside edge.

DESCRIPTION OF MACHINE PARTS

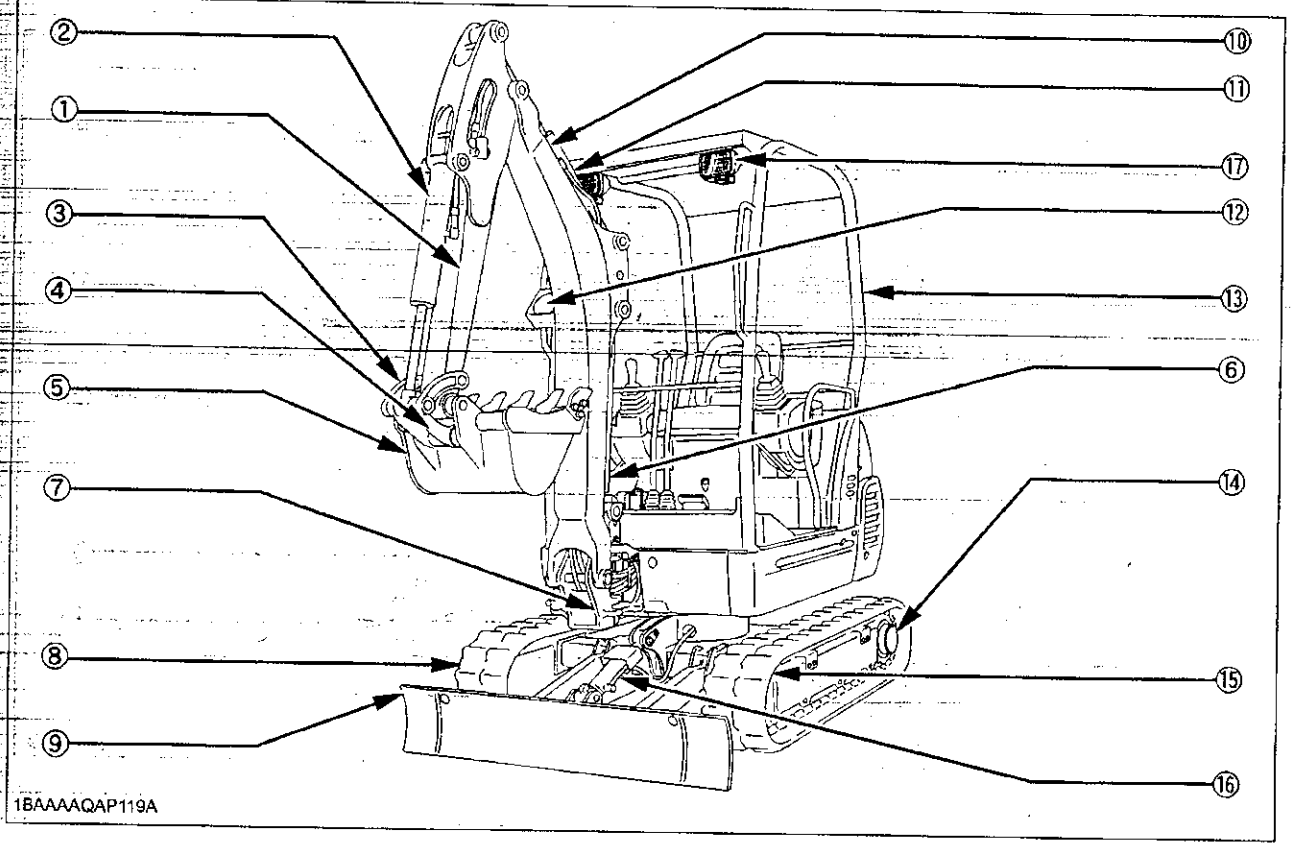

1BAAAQAP119A

- DEPICTED CONTENTS**
- (1) Arm
 - (2) Bucket cylinder
 - (3) Bucket link 2 and 3
 - (4) Bucket link 1
 - (5) Bucket
 - (6) Boom cylinder
 - (7) Swing bracket
 - (8) Track
 - (9) Dozer blade
 - (10) Boom
 - (11) Arm cylinder
 - (12) Working light
 - (13) Canopy (Rops / Fops)
 - (14) Drive sprocket
 - (15) Front idler
 - (16) Dozer cylinder
 - (17) Working light (option)

INSTRUMENT PANEL AND CONTROL ELEMENTS

Instrument Panel, Switches

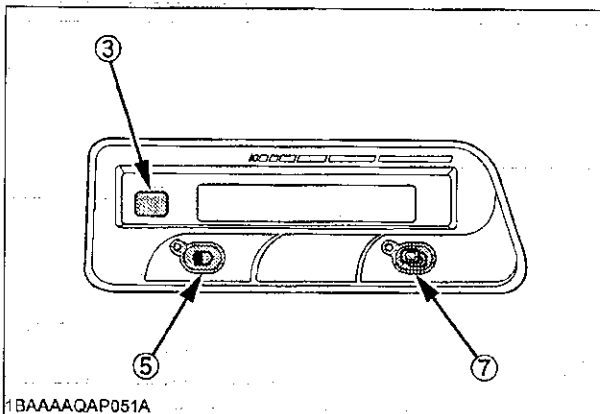
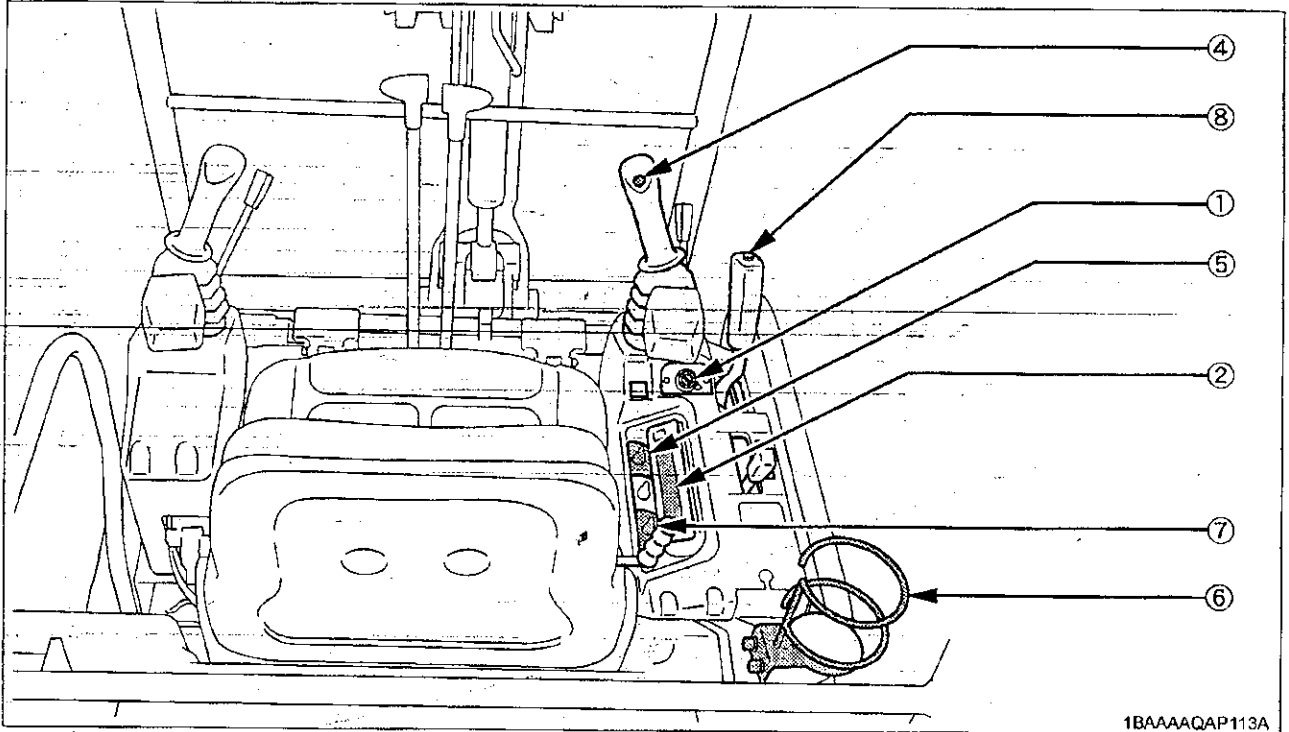

DEPICTED CONTENTS

- (1) Starter switch
- (2) LCD display
- (3) Warning lamp
- (4) Horn switch
- (5) Working Light switch
- (6) Cup holder
- (7) Display selector switch
- (8) Travel speed switch

■ Control Pedals and Levers

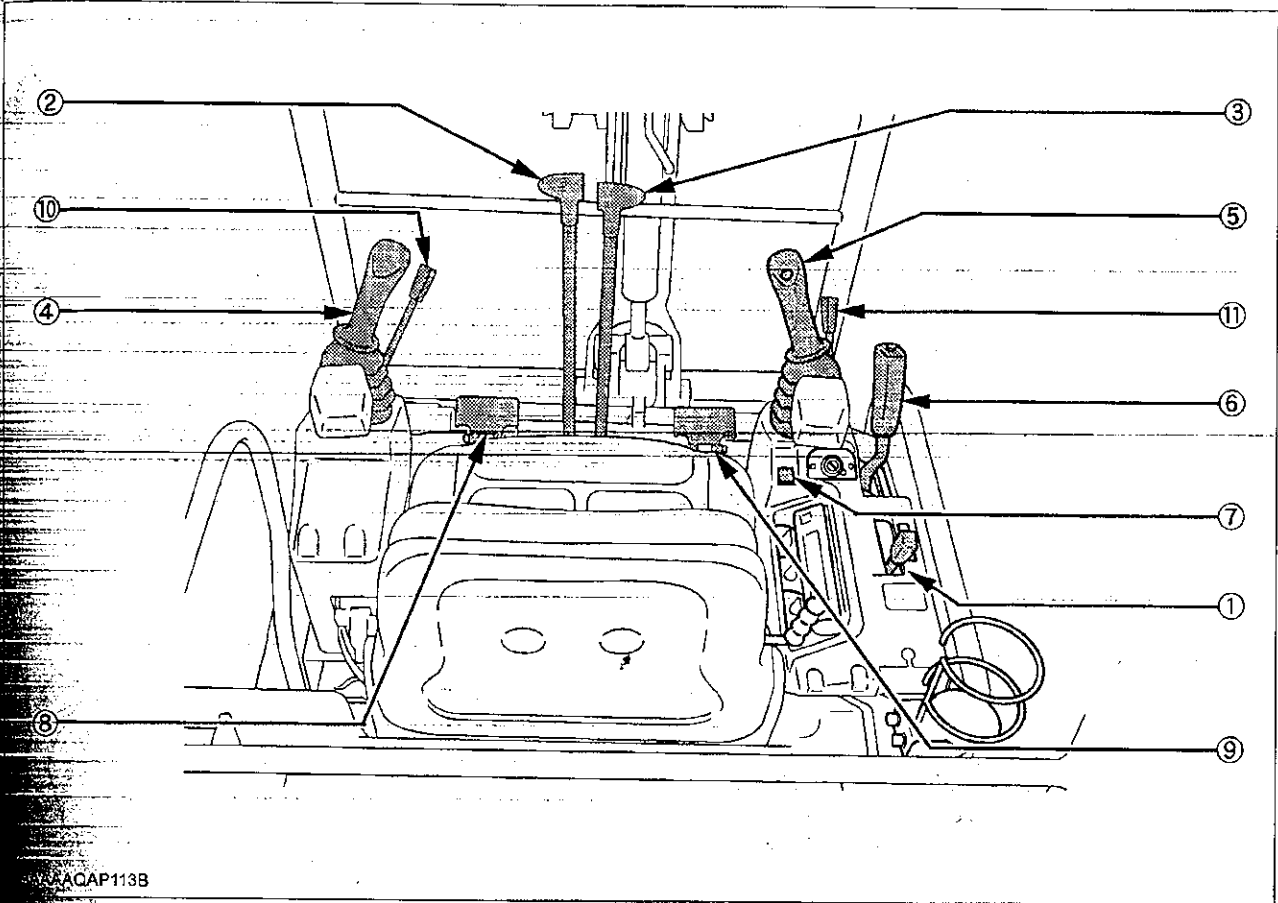

AQAP113B

INDICATED CONTENTS

- Throttle lever
- Drive lever (left)
- Drive lever (right)
- Control lever for front attachments (left)
- Control lever for front attachments (right)
- Zero control lever
- Red indicator light
- Service port pedal
- Boom swing pedal
- Lock lever*
- Lock lever*

NOTE:

When the lock lever pulled up prevents inadvertent machine movement.

CHECKS BEFORE START

DAILY CHECKS

In order to avoid damage, it is important to check the condition of the excavator before starting.



CAUTION

To avoid personal injury:

- Do maintenance work on the excavator only on even ground with the engine off and the lock lever in the "Lock" position.

Checks

Go around the excavator and check for visual damage and wear.

Check coolant level. (See regular checkpoints in the chapter on maintenance.)

Check fuel level.

Check engine oil level.

Check hydraulic fluid level.

Check air filter for clogging.

Check all control lamps, indicators, tachometer and hour meter.

Check the light system.

Check the seat belt and the ROPS/FOPS safety device.

Check the condition of the safety and warning labels.

(See "DANGER, WARNING AND CAUTION LABELS" in "SAFE OPERATION".)

OPERATION OF THE ENGINE



CAUTION

To avoid personal injury:

- Read "SAFE OPERATION" at the beginning of this operator's manual.
- Obey the danger, warning and caution labels on the excavator.
- To avoid the danger of exhaust fume poisoning, do not operate the machine in a closed building without proper ventilation.
- Always start the engine from the operator's seat. Do not start the engine while standing next to the excavator. Before starting the engine, sound the horn to get the attention of persons standing nearby.

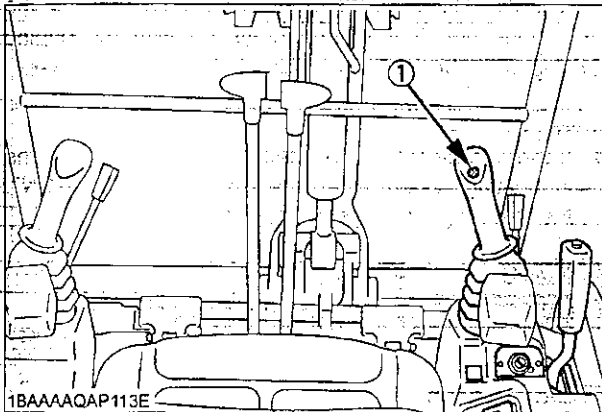

1BAAAAQAP113E

(1) Horn switch

IMPORTANT :

- Do not use starting fluid or ether.
- In order not to overload the battery and starter, avoid start-ups of more than 10 sec.
- When engine does not start in 10 sec., please wait 20 sec. or more, before attempting to restart.

STARTING THE ENGINE



CAUTION

To avoid personal injury:

- The operator should not depend solely on the warning lamps, but should always conduct the routine checks (see "MAINTENANCE").

Start the engine in the following manner:

1. Before starting the engine, make sure that all control levers are in the neutral positions.

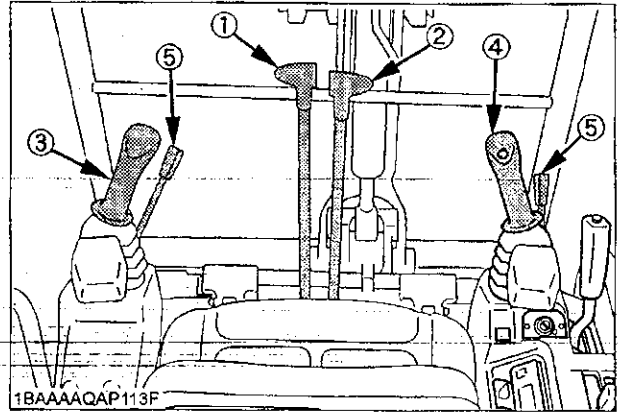

1BAAAAQAP113F

- (1) Drive lever (left)
- (2) Drive lever (right)
- (3) Attachment control lever (left)
- (4) Attachment control lever (right)
- (5) Lock lever

2. Pull the lock levers all the way back. (lock position)
 - Put the throttle lever towards
3. Insert the key into the starter switch and turn it to the position "Run". The glow lamp indicator will light up while the engine is preheated and will go out automatically after preheating is finished.

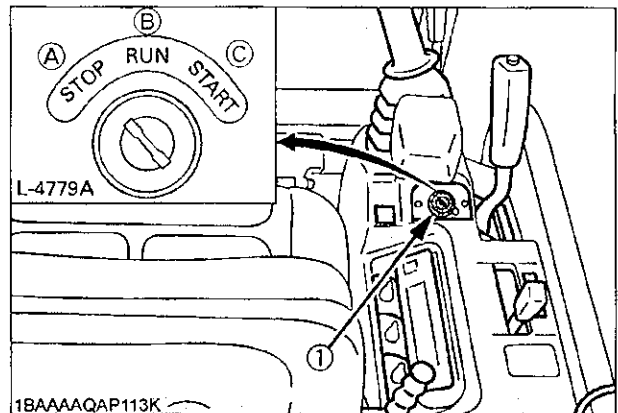

L-4779A

- (1) Starter switch
 - (A) "STOP"
 - (B) "RUN"
 - (C) "START"

4. Turn the key to the position "START" and release after the engine has started.
5. Check if oil lamp and charge lamp have gone out. Should a warning lamp still be lit up, stop the engine then remove the key and check for the cause.

■ Display Selector Switch

Press the display selector switch. The electronic meter's LCD display will change from one indication mode to the other.

Change the two-mode display according to your jobs.

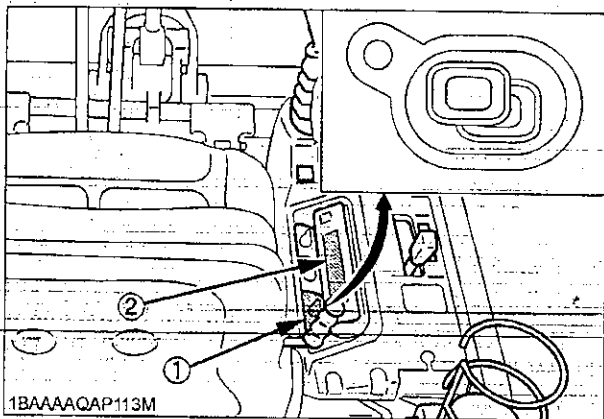

- (1) Display selector switch
- (2) LCD display

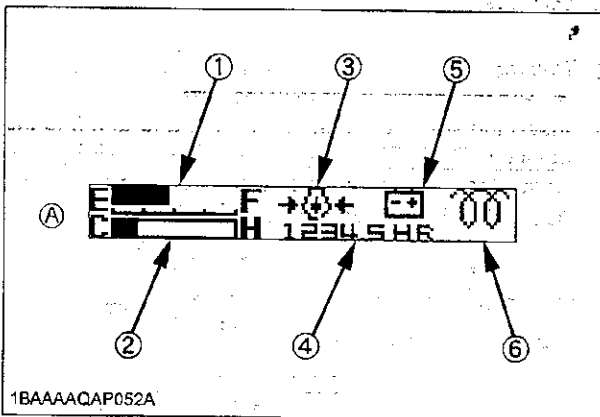

- (1) Fuel gauge
- (2) Water temperature gauge
- (3) Oil lamp
- (4) Hour meter
- (5) Charge lamp
- (6) Glow lamp

NOTE :

- With the starter key at the "STOP" position, press the electronic meter's display selector switch or the working light switch, and the LCD display shows the hour meter, fuel gauge and water temperature gauge for 10 seconds.

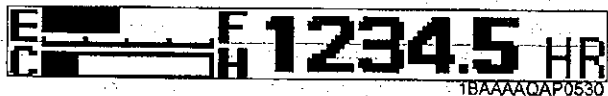

■ Charge Lamp

This warning lamp lights up if the charging system fails the engine running. When the starter switch is turned "ON" with the engine off, the lamp lights up, and when the engine gets started, the lamp goes out.

NOTE :

- If there is disconnection or failure in the charging system when the key is turned to "RUN", the following message will appear.



■ Oil Lamp

The engine oil pressure warning lamp lights up due to failure of the lubricating system with the engine running. When the starter switch is turned "ON" with the engine off, this lamp lights up, and when the engine starts, the lamp goes out. If the lamp stays on with the engine running, stop the engine and check the engine oil level.

NOTE :

- If there is disconnection, failure or breakdown in the lubricating system when the key is turned to "RUN", the following message will appear.



■ Glow Lamp

With the starter key at the "RUN" position, the engine's preheat status is indicated.

NOTE :

- When the starter switch is turned to the "RUN" position, the engine will be preheated for a given period of time and the lamp will turn on.
- The above indication appears momentarily when the engine is started, but it does not mean any trouble. (This is because the oil charge sensor output becomes unstable when the engine is started.)
- The □ symbol appears momentarily as the engine starts. This is not an error.

LCD Display for Normal Operation

Fuel gauge

CAUTION

To avoid personal injury:

- Before adding fuel, be sure to stop the engine.
- Be sure to keep open flame away from the machine. Otherwise a fire may be caused.

With the starter key at the "RUN" position, the fuel remaining in the fuel tank is indicated in the block.

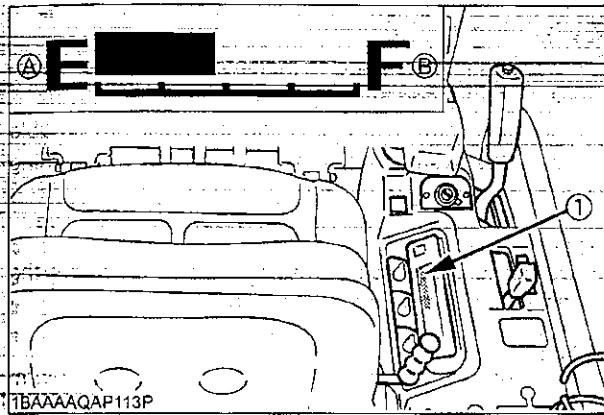

(1) Fuel gauge (A) "Empty" (B) "Full"

NOTE:

- If the fuel gauge indicator is near the "E" or the "FUEL" message appears, add fuel as soon as possible. If the indicator is near "E" and the machine runs on a slope, the engine may run out of fuel and get interrupted.

Fuel supply

CAUTION

To avoid personal injury:

- If the fuel is poured too fast, the buzzer may not sound according to the fueling process.
- The moment when the buzzer starts beeping means that the fuel tank is nearly full.
- Look into the fuel tank when pouring the fuel. Listen to the buzzer sound for rough-checking the fill-up progress.

The following functions are helpful when adding the fuel. The fueling process can be monitored by a buzzer sound.

Procedure

1. Press the work light switch or the display selector switch on the meter with the key OFF. (Keep the key at OFF.)



2. The message shown above appears.
3. Add fuel.
4. The buzzer sound interval changes according to the amount fuel added. As the fuel amount becomes close to full; the buzzer sound changes to continuous beeping.

Water Temperature Gauge

CAUTION

To avoid personal injury:

- Do not open the radiator cap during and just after operation. Hot water may gush out and scald you. Wait until the radiator cools down enough before opening the cap.

With the starter key at the "RUN" position, the cooling water temperature is indicated. If the water temperature indicator is near "H", take the steps below.

1. Discontinue the job.
2. Reduce engine rpm's to idle and keep it at idle for 5 minutes.
3. Stop the engine and check the following points (1)-(3).
 - (1) Low coolant level or leak
 - (2) Fan belt tension
 - (3) Mud or dust deposits on radiator

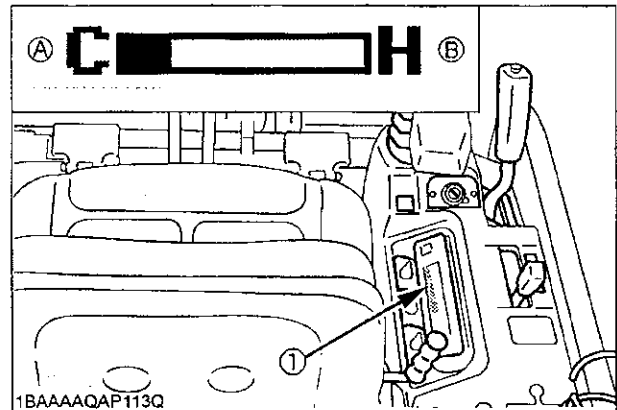

(1) Water temperature gauge (A) "WATER TEMP LOW" (B) "WATER TEMP HIGH"

◆ Hour-meter

Indicates the total operating hours of the machine.

How the indicator works

- The meter advances one hour after an hour of operation regardless of the engine rpm.

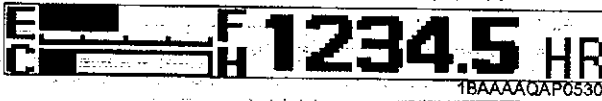

◆ Engine tachometer

Indicates the current rpm of the engine.



NOTE:

- The LCD display may be illegible when viewed from a certain angle. This is not a display failure.

■ LCD Display for Warning

◆ Remaining fuel warning

When the fuel level is very low, the ▲ lamp (yellow) starts flashing and the following message appears in the display.

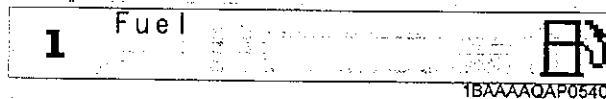

◆ Battery charge warning

If the charging system fails, the ▲ lamp (red) starts flashing and the following message appears in the display.

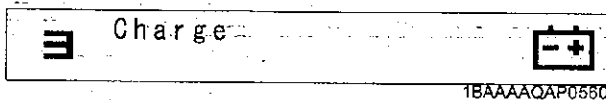

◆ Engine oil pressure low warning

When the engine oil pressure drops too low, the ▲ lamp (red) starts flashing and the following message appears in the meter.

Immediately stop the engine and check the engine oil level.

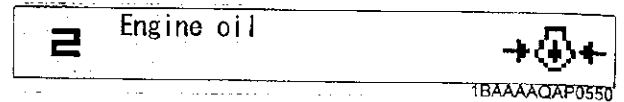

■ Warning Lamp

The warning lamp is used to indicate broken wire, short-circuit, fuel shortage and other problems.

The warning lamp starts flashing in red if any trouble occurs. If the system gets in warning signal, the warning lamp starts flashing in yellow.

IMPORTANT:

- Do not just look at the meter, but also carry out the inspection and correction accordingly.

NOTE:

- Warnings and errors are displayed and an alarm buzzer beeps.
- Let your KUBOTA dealer inform you of details concerning care and maintenance.

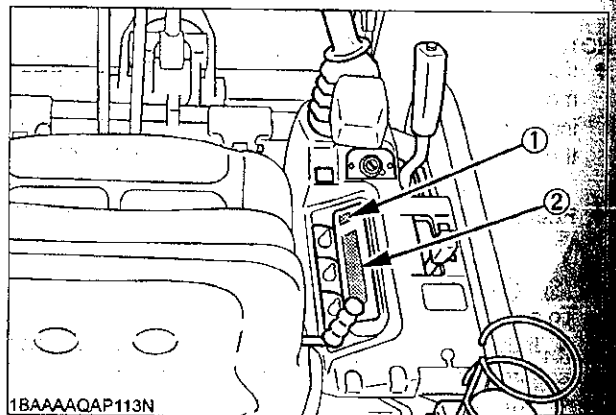

- (1) Warning lamp (red, yellow)
- (2) LCD display

STARTING THE ENGINE UNDER COLD CONDITIONS



CAUTION

To avoid personal injury:

- Make sure that the lock lever is in the lock position during warm up.

Start the engine in the following manner;

1. Pull the lock levers all the way back (lock position).
2. Turn the starter switch to the position "RUN" (glow position) and keep until the indicator lamp has gone out.
3. Move the starter switch to the position "START"; to crank and start engine.
4. Release the starter switch after the engine has started; it will automatically return to the position "RUN".

IMPORTANT :

- Let the engine warm up after start-up for approx. 10 minutes under no load conditions. If the hydraulic fluid temperature is too low, the operations will be affected. Do not operate the excavator under full load before the engine has warmed up enough.

Checkpoints after Starting the Engine

After starting the engine, but before starting operation, check the following points:

Put the throttle lever down and let the engine idle for approx. five minutes. This allows the engine lubricant to warm up and penetrate every part of the engine.

This idling is usually called "Warm-up".

Once the engine has warmed up, check:

- the warning lamp "Engine oil pressure" has gone out.
- the warning lamp "Battery charge" goes out when engine speed is increased.
- the color of the exhaust is normal and no abnormal noises or vibrations are heard or felt.
- no fluid is leaking from pipes or hoses.

Should any following conditions occur, stop the engine immediately.

- The engine rpm's increases or decreases suddenly.
- Sudden abnormal noises are heard.
- Exhaust is black.
- Warning lamp for engine oil lights up during operation.

IMPORTANT :

In these cases, the excavator must be checked and serviced by your local the KUBOTA dealer.



■ Precautions in case of Overheat

⚠ CAUTION

To avoid personal injury:

- Do not open the radiator cap during and just after operation. Hot water may gush out and get you burned. Wait long enough until the radiator cools down.

If by any chance cooling water gets heated up to the boiling point or over (overheated), the whistle at the reserve tank drain hose end blows. In such case, take the following steps:

1. Stop operation in a safe condition.
(Disconnect the engine's load.)
2. Do not stop the engine suddenly. Keep the engine idling under no load for about 5 minutes and turn it off.
3. Keep yourself enough away from the machine for another 10 minutes or while steam is given off.
4. Make sure there is no hazard of getting burned. Pinpoint and remove the cause of overheat, referring to "TROUBLESHOOTING". Then get the engine restarted.

STOPPING THE ENGINE

⚠ WARNING

To avoid personal injury or death:

- Do not keep the bucket or dozer in the lifted position, as a person could accidentally touch the levers and cause serious accidents.

1. After slowing the engine to idle, turn the key to "STOP".
2. Remove the key.

■ Emergency Engine Stop Fuse

⚠ CAUTION

To avoid personal injury:

- Do not open engine hood before stopping engine. Only when engine does not stop by key, open engine hood and pull out the fuse.

The engine will stop when the cap is removed and the fuse inside is pulled out. The engine can be restarted when the fuse is pushed back into its original position.

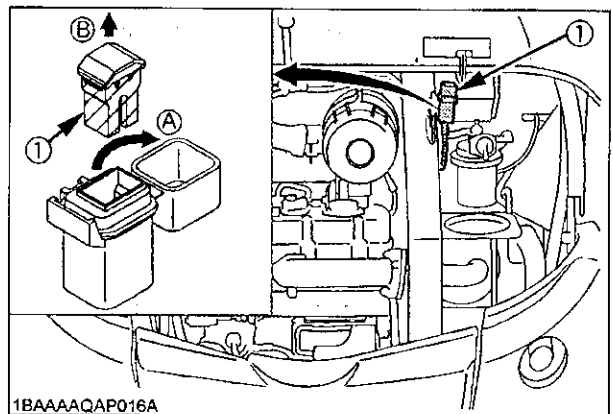

1BAAAAQAP016A

(1) Emergency engine stop fuse

(A) "OPEN"

(B) "PULL OUT"

NOTE :

- If the engine does not stop with the key, contact your KUBOTA dealer.

STARTING WITH AN AUXILIARY BATTERY**CAUTION**

To avoid personal injury:

- Battery gases can explode. Do not smoke and keep sparks and flames away.
- Do not start the engine with an auxiliary battery if excavator battery is frozen.
- Do not connect the black jumper cable to the negative (-) terminal of the excavator battery.

■ **Observe Following Guidelines when Starting with an Auxiliary Battery**

1. Bring the helping machine with the same battery voltage as near as possible to the excavator.

THE MACHINES MUST NOT COME IN CONTACT WITH EACH OTHER.

2. Bring the levers and pedal of both vehicles in the neutral position and put the lock lever in the "Lock" position.
3. Wear eye protection and rubber gloves.
4. Ensure the vent caps are securely in place (if equipped).
5. Cover the battery opening with a cloth. Make sure that the cloth does not touch the battery terminals.
6. Connect the terminal of the red jumper cable with the plus (+) terminal of the low battery and connect the other end of the cable to the plus (+) terminal of the auxiliary battery.
7. Connect the black negative cable to the minus (-) terminal of the auxiliary battery.
8. Connect the other end of the black cable (coming from the auxiliary battery) to the excavator frame as far away as possible from the low battery.
9. Start the engine of the helping machine and let it run for a while. Start the excavator with the low battery.
10. Disconnect the jumper cables in the reverse sequence (Steps 8, 7, 6).

11. Remove the cloth and replace the battery caps.

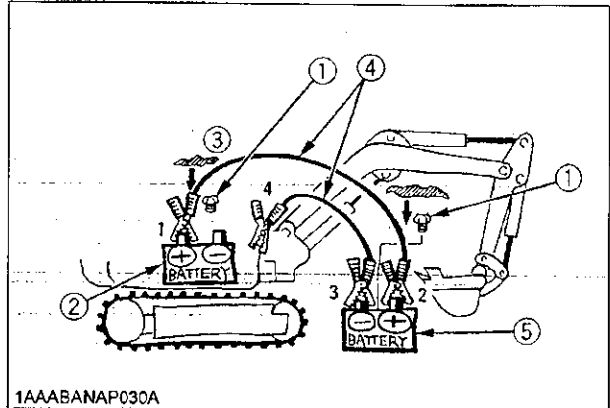

- (1) Lay a damp rag over the vent caps
- (2) Low battery
- (3) Put a cloth over the battery openings
- (4) Jumper cables
- (5) Auxiliary battery

IMPORTANT :

- This excavator has a negative (-) earthed 12 Volt starting system.
- Only use the same voltage when using an auxiliary battery.
- Using a higher voltage will cause serious damage to the electrical system. When using an auxiliary battery, only the compatible (same) voltage is permissible.

EXCAVATOR OPERATION

RUNNING-IN OF THE NEW EXCAVATOR

The operation and care of the new excavator influences its life span. Your new excavator has been carefully checked and tested before leaving the factory. In spite of this, all movable components must run-in during the first 50 work hours. Do not work with full rpm's and full loads during this period. It is most important to run-in your excavator properly in order to achieve its full performance and longevity. During the running-in, the following points should be adhered to in all cases.

■ Do not Work with Full Engine Rpm's or Full Loads during the First 50 Working Hours

- Let the engine warm up sufficiently in the cold season.
- Do not let the engine rev-up more than necessary.

■ Oil Change in the Run-in Stage

The lubrication oil plays a specific and important role during the run-in phase of the excavator. The numerous movable parts are not yet run-in, so many fine metal particles are generated and cause damage and shorten the life of many components. Pay attention to the oil-change intervals and complete them sooner than later. See the subject "Care and Maintenance" for more details on the oil-change intervals.

■ Seat Belt

WARNING

To avoid personal injury or death:

- Always use the seat belt with a ROPS/FOPS protection structure. Adjust the seat to the optimal position and buckle up.

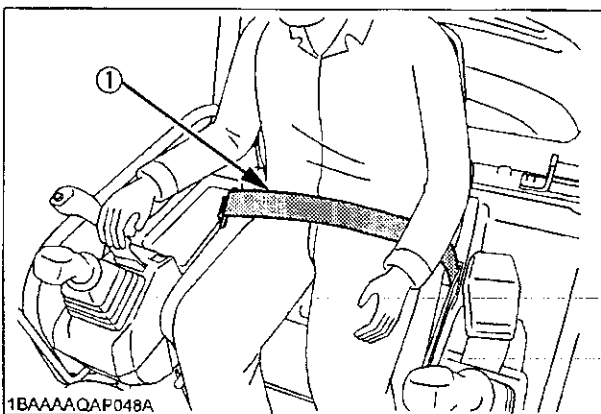

(1) Seat belt

STARTING

1. Adjusting the Operator's Position.

■ Operator's Seat

CAUTION

To avoid personal injury:

- Make sure that the seat is completely secured after each adjustment.
- Do not allow any person other than the driver to ride on the excavator.

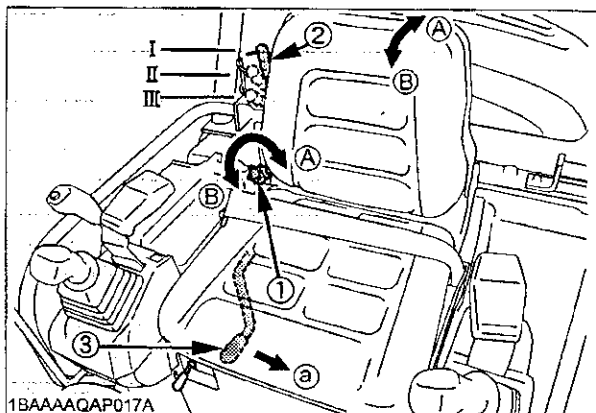

(1) Knob for tilt

(2) Adjustment lever

(3) Travel adjust lever

(a) "UNLOCK"

◆ Tilting the back rest : (1)

To tilt the backrest back (direction (A)), turn the knob clockwise.

To set the back rest forward (direction (B)), turn the knob counterclockwise.

◆ Adjustment of seat suspension : (2)

Set the lever position according to the operator's weight.
 position I : For light operator
 position II : For middle operator
 position III : For heavy operator

◆ Travel adjustment : (3)

Pull the travel adjust lever and slide the seat backward or forward, as required. The seat will lock in position when the lever is released.

Operator's Seat for Australia

CAUTION

To avoid personal injury:

- Make sure that the seat is completely secured after each adjustment.
- Do not allow any person other than the driver to ride on the excavator.

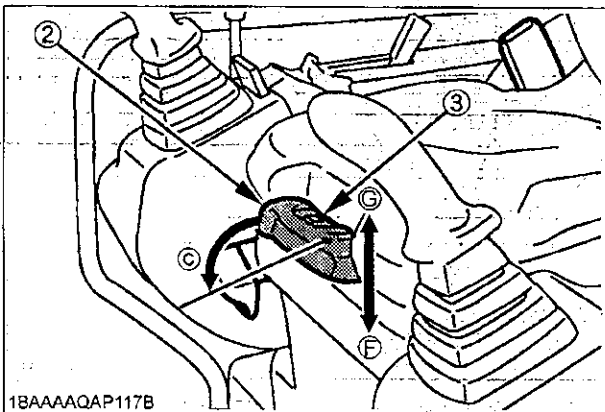
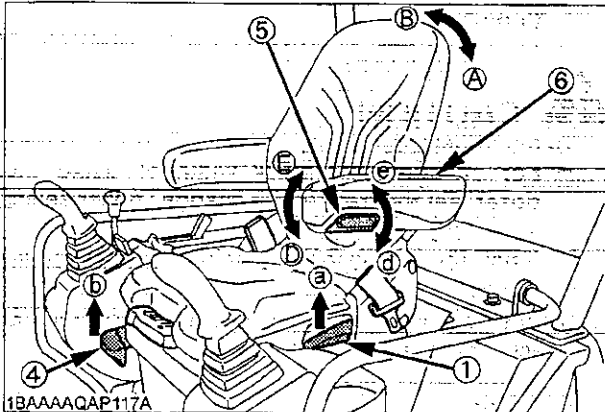

- | | |
|--------------------------------------|---------------|
| (1) Backrest angle adjust knob | (a) Unlock |
| (2) Weight adjust lever | (b) Unlock |
| (3) Weight indicator | (c) Swing 90° |
| (4) Travel adjust lever (Horizontal) | |
| (5) Armrest angle adjust knob | |
| (6) Armrest | |

◆ **Backrest angle adjust knob : (1)**

- Pull up and unlock the backrest angle adjust knob (1). Reposition the backrest in Direction A or B to an optimum angle.

◆ **Driver's weight adjustment : (2)**

- Sit on the seat and swing the weight adjust lever (2) 90° in Direction (c).
- Move up or down the lever (2) several times until the arrow mark comes to the center of the weight indicator (3).

- Move up the lever (2) toward G from the center (free state), and the spring force gets stronger. Move it down toward F, and the spring force gets weaker.

◆ **Travel adjustment (Horizontal) : (4)**

- Pull up and unlock the travel adjust lever (horizontal) (4). Slide the seat back and forth to an optimum position.
- Make sure the seat has got locked in the desired position.

◆ **Armrest angle adjustment : (5)**

- Turn up or down the armrest angle adjust knob (5) to position the armrests to an appropriate angle.
- Turn up the knob (5) toward (e) to tilt up the armrests toward E. Turn it down toward (d) to tilt them down toward D.

2. After starting the engine, bring the lock levers into the "Unlock" position to use drive lever or control lever for front attachments.

Lock Lever

CAUTION

To avoid personal injury:

- To avoid injuries, check safety features all around the excavator.

NOTE :

- With the lever lock pulled down, the engine fails to start.

If you try to start the engine with the key with the lock lever down, the following message appears momentarily on the meter display.



1BAAAQAP0670

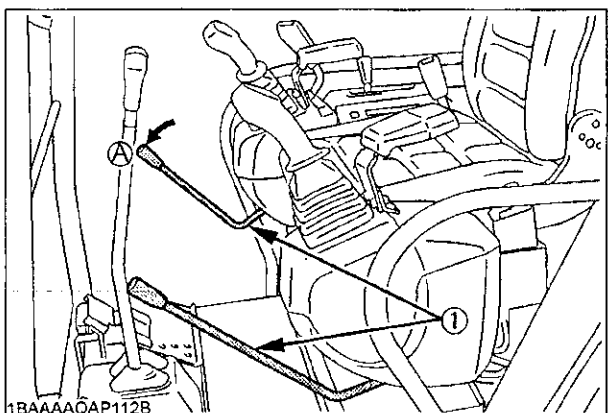

- (1) Lock lever (Unload lever) (A) "Unlock"

■ Working Light Switch

When the starter switch is in position "RUN", the light(s) can be switched on by pressing the switch.

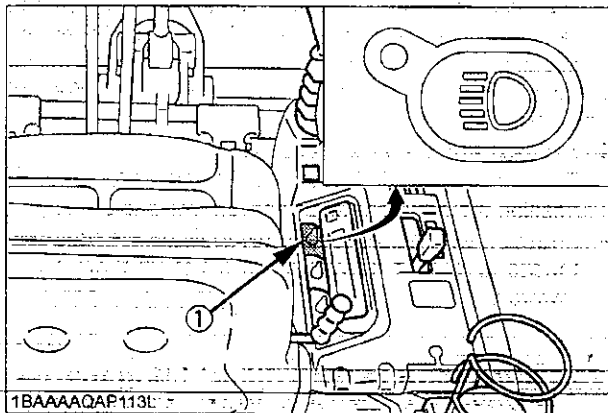

(1) Working light switch

◆ Night operation

⚠ CAUTION

To avoid personal injury:

- Visibility is reduced in darkness, therefore the work light alone may not be enough. In which case, prepare additional stationary artificial lighting, observe safety rules as well as special regulations for night work.

■ Travel Buzzer (Option)

When you handle the drive levers, the buzzer sounds at the same time or before the excavator starts to run.

OPERATION OF TRACK WIDTH CHANGE AND DOZER

⚠ WARNING

To avoid personal injury or death:

- Operate always in standard track width 1300mm(51.2 in.), except to pass through narrow space.
- Do not operate in narrow track width 990mm(39.0 in.), it makes risk of the excavator tipping over.

⚠ CAUTION

To avoid personal injury:

- For changing the track width or using the dozer, set the track width change / dozer select lever fully.
- If not, the excavator may unintentionally move.

1. Set the track width change / dozer select lever to the "Track width change" position (B).

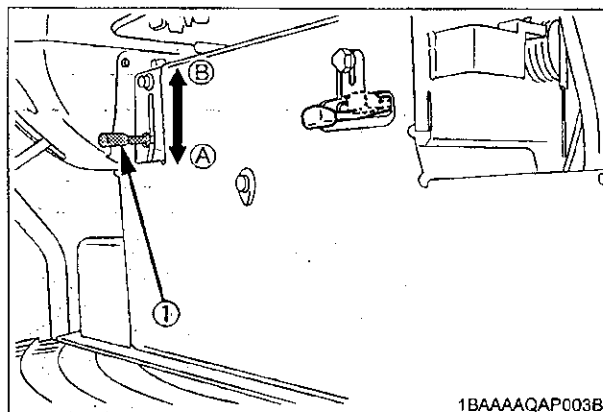

(1) Track width change / dozer select lever

(A) "Dozer"
(B) "Track width change"

2. Push the dozer control lever forward. ... The track width increases (from 990 mm (39.0 in.) to 1300 mm (51.2 in.)). Pull the dozer control lever backward. ... The track width reduces (from 1300 mm (51.2 in.) to 990 mm (39.0 in.)).

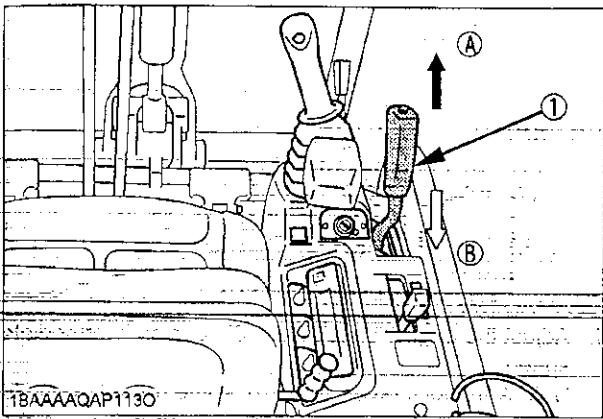

(1) Dozer control lever (A) "Increase" (B) "Reduce"

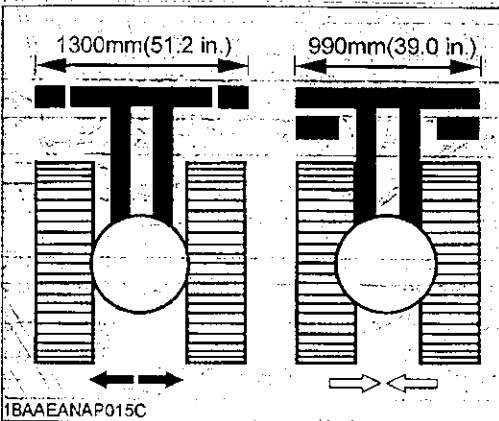

3. After track width change, be sure to set the track width change/dozer select lever to the "Dozer" position (A).

■ Adjustment of the Dozer Width

For changing from standard width to narrow width:

1. Pull out the fixing pin (2) and remove the extension dozer (1).
2. Set as under illustration the extension dozer (1), insert fixing pin (2).
3. It is the same operations for opposite side (left or right), and also for changing from standard width to wide width.

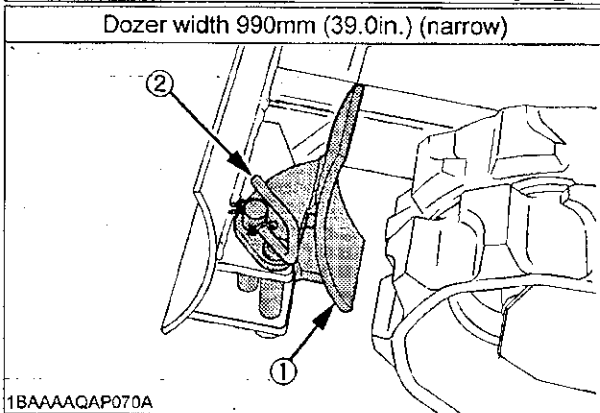
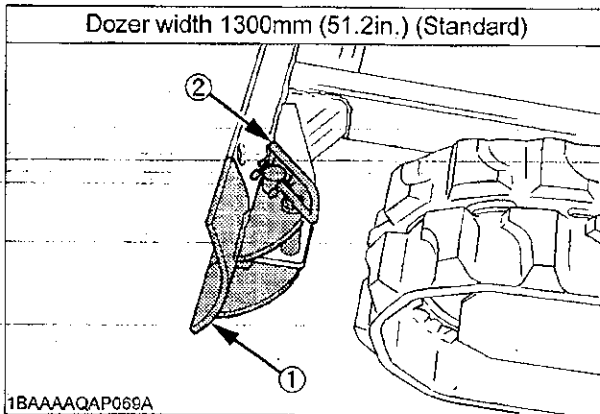

(1) Extension dozer (2) Fixing pin

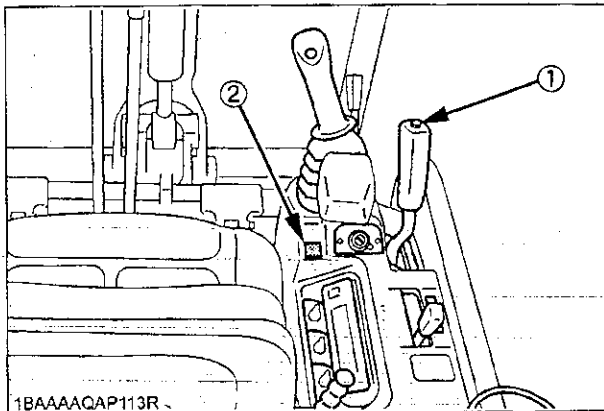

1BAAAQAP113R

- (1) Travel speed switch
- (2) Speed indicator light

NOTE:

- When activating the travel speed switch, it must be pushed down completely.
- Each time the travel speed switch is pressed, the travel speed is switched between first and second.

IMPORTANT:

- Do not activate the travel speed switch when there is increased drive resistance (e.g. driving on inclines or on uneven grounds).
- If the track are clogged with sand or gravel while working on soft ground, lift up one track with the help of the boom, arm and bucket and let the track rotate to remove the sand and gravel.

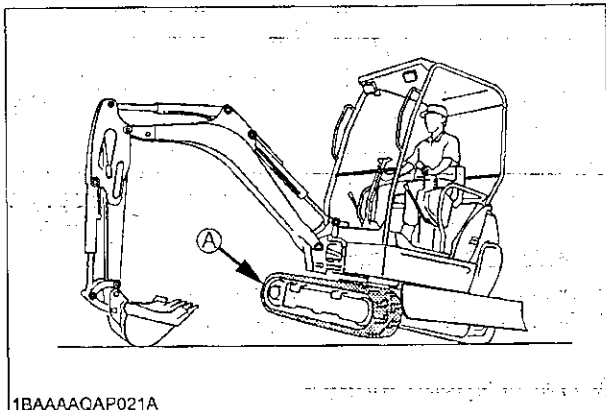

1BAAAQAP021A

(A) "Rotate to remove sand and gravel"



DANGER

To avoid serious injury or death:

- Do not work under the machine in this condition.

TURNS



CAUTION

To avoid personal injury:

- Do not change direction on steep slopes, or the excavator could tip over.
- Before changing direction, beware of people in the work area.

■ Pivot Turn

NOTE:

- Movement as illustrated is done with the dozer blade in front of the operator.

When the dozer is in the back, the steering direction is reversed.

(For example, push the left drive lever forward the excavator turns right; the left track, seen from the operator, will move backward from the operator.)

◆ Change of Direction while Travelling

1. While travelling forwards, bring the left drive lever into the neutral position; the excavator will turn to the left.

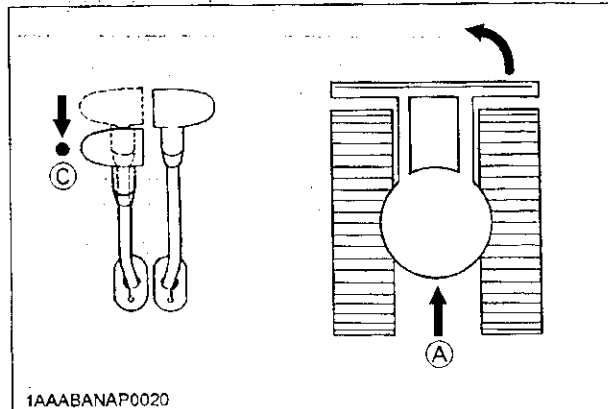

1AAABANAP0020

(A) "Travelling forward"

(C) "Neutral position"

2. While travelling backwards, bring the left drive lever into the neutral position; the excavator will turn to the right.

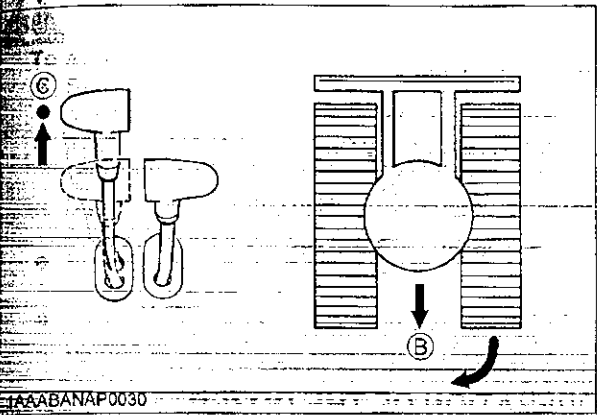

1AAABANAP0030

(B): "Travelling backward" (C): "Neutral position"

◆ Change of Direction while Stationary

1. Push the left drive lever forward; the excavator will turn to the right.

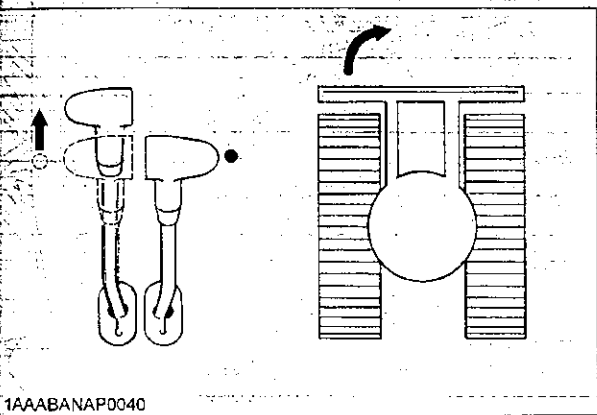

1AAABANAP0040

2. Pull the left drive lever backward; the excavator will turn to the left.

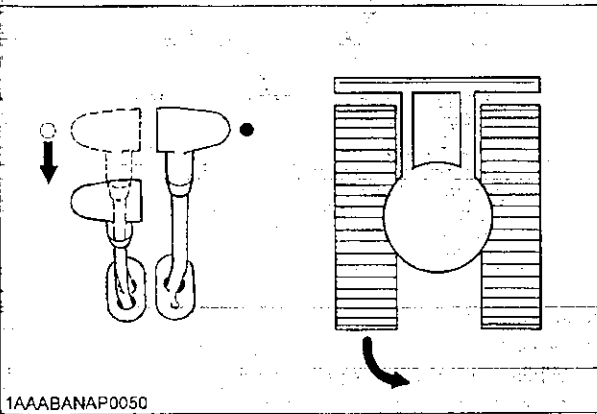

1AAABANAP0050

■ Spin Turn

When both drive levers are activated in the opposite directions, both tracks will rotate with the same speed but in opposite directions. The center of rotation is the center of the excavator.

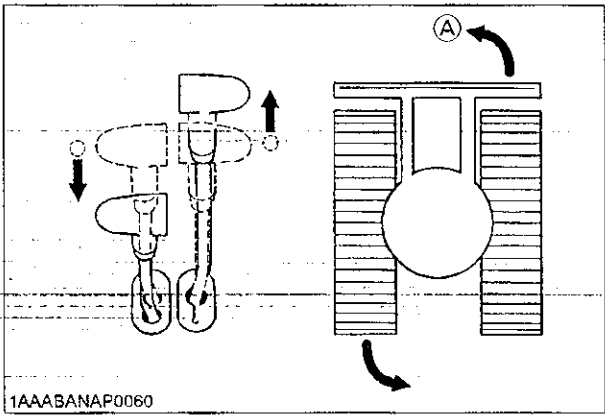

1AAABANAP0060

(A) "Left spin turn"

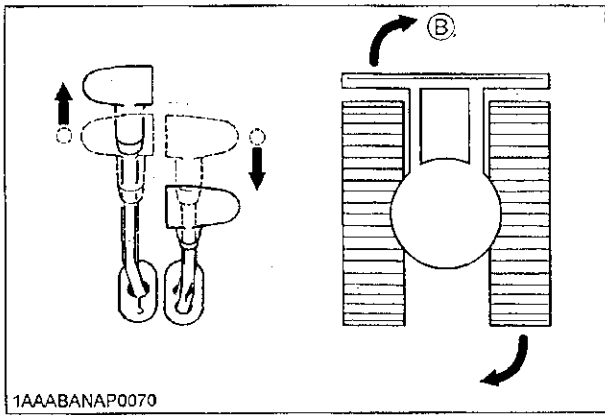

1AAABANAP0070

(B) "Right spin turn"

UP AND DOWNHILL DRIVING

CAUTION

To avoid personal injury:

- Before travelling up and downhill, be sure to be in standard track width (1300mm).
- When travelling up or down a slope for long periods of time, be sure to engage the swing lock pin. Also engage the swing lock pin when standing on a slope for a long time or the excavator is being transported.

While traveling uphill, keep the lower edge of the bucket approx. 20 to 40 cm (8 to 16 in.) above the ground. Although the KUBOTA excavator will not slip easily because of the tracks, it is safer to let the bucket slide over the ground while traveling downhill. Always choose slow speed for uphill and downhill traveling.

[UPHILL TRAVELING]

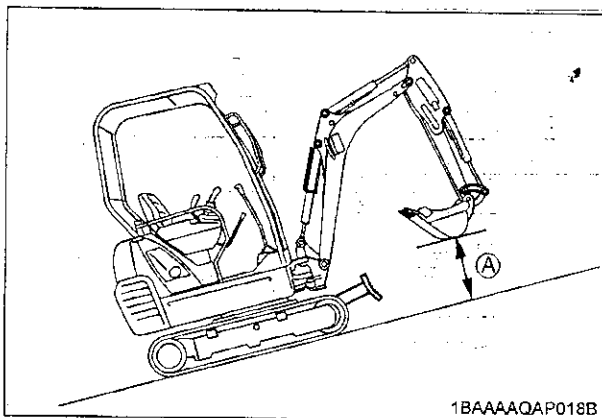

1BAAAQAP018B

(A) 20 to 40 cm (8 to 16 in.)

[DOWNHILL TRAVELING]

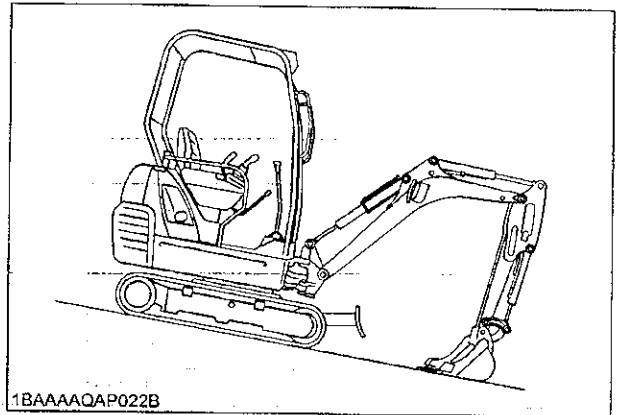

1BAAAQAP022B

OPERATION OF THE DOZER

1. To raise the dozer, set Dozer and Track selection lever in position of Dozer and pull back the control lever. Pushing the control lever forwards, lowers the dozer.

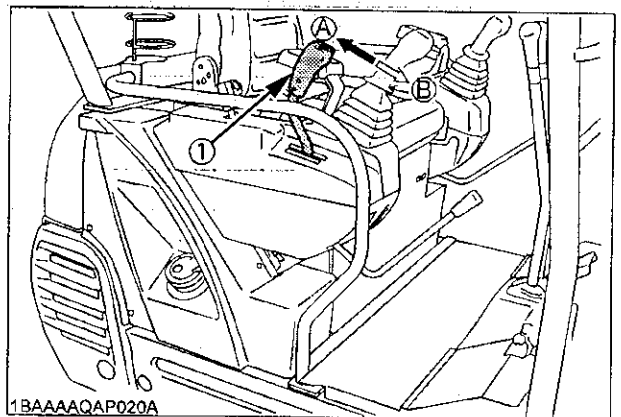

1BAAAQAP020A

(1) Dozer control lever

(A) "Raise"

(B) "Lower"

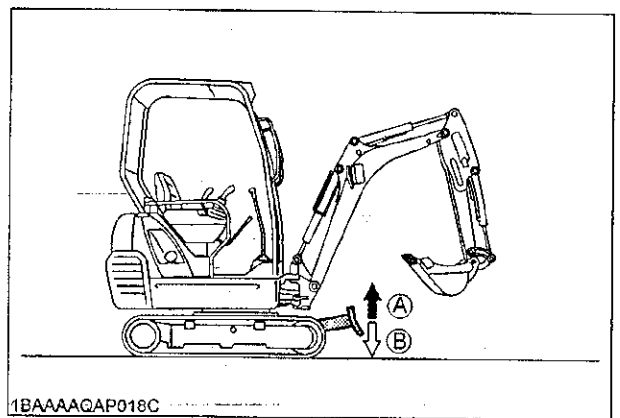

1BAAAQAP018C

(A) "Raise"

(B) "Lower"

2. While undertaking earth moving work, control both drive levers with the left hand and the dozer control lever with the right hand.

TWO PATTERN SELECTION SYSTEM(TPSS)



CAUTION

To avoid personal injury:

- Study control lever pattern A and pattern B. Then choose the one which is most familiar
- Position the pattern selector lever (located on the right side of operator's seat) in either the full left hand side position (pattern A) or the full right hand side position (pattern B).
- Engage the lever lock to prevent accidental pattern change.
- Familiarize yourself with the pattern selected by operating slowly.

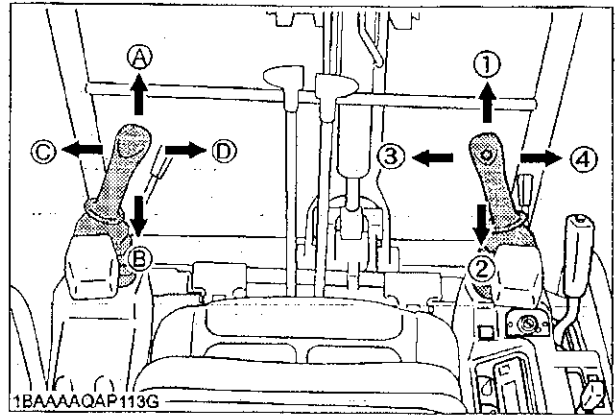

1BAAAAQAP113G

Pattern Change

1. Loosen the lever lock knob (2) and slide it to the direction (a), and position the pattern selector lever (1) to the desired position.
2. Slide the lever lock knob (2) to the direction (b) and tighten it.

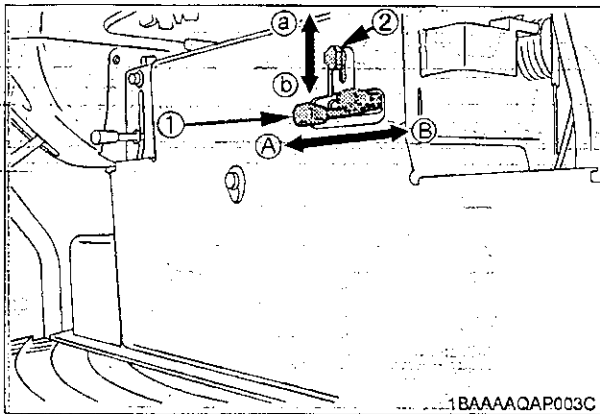

1BAAAAQAP003C

- (1) Pattern selector lever (Two Pattern Selection System:TPSS) (a) "UNLOCK"
 (2) Lever lock knob (b) "LOCK"

Lever Position		Pattern A	Pattern B
Attachment Control Lever (Left)	A	Boom down	Arm up
	B	Boom up	Arm crowd
	C	Swing left	Swing left
	D	Swing right	Swing right
Attachment Control Lever (Right)	1	Arm up	Boom down
	2	Arm crowd	Boom up
	3	Bucket crowd	Bucket crowd
	4	Bucket dump	Bucket dump

OPERATION OF THE BOOM

To raise the boom, pull the attachment control lever back. The boom is equipped with a cushion cylinder which helps prevent excavated material in the bucket from falling out. Low hydraulic oil temperature, (e.g. after starting the engine in cold weather) the cushioning function will be effected for a short period of time (approx. 3 to 5 seconds). This condition results from the viscosity of the hydraulic oil and is not a sign of malfunction.

The cushion cylinder will operate normally as the oil warms up.

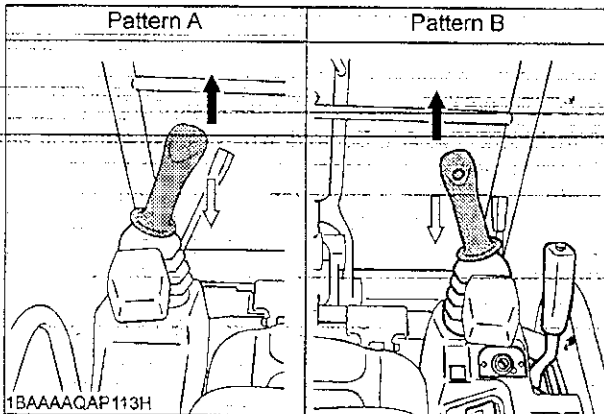

1BAAAAQAP113H

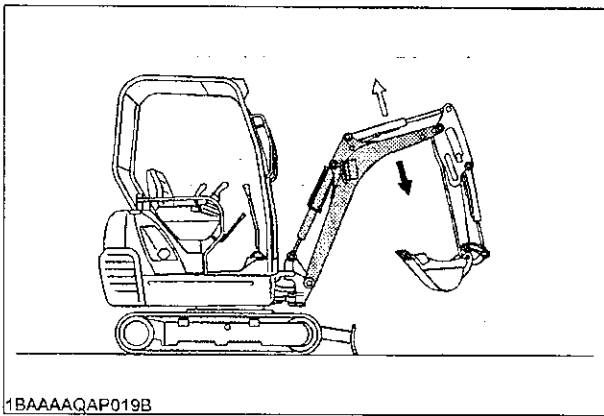

1BAAAAQAP019B

IMPORTANT :

- When lowering the boom, make sure that it does not hit the dozer and that the bucket teeth do not touch the dozer.

OPERATION OF THE ARM

Pull back the attachment control lever and the arm will be pulled in. To move the arm out, push the control lever towards the front.

NOTE :

- When pulling in the arm, the movement may stop for a short moment when the arm is in its vertical position. This is caused by the combined load of the arm and bucket moving the cylinder piston away from the hydraulic flow causing a delay in the cylinder action, until the flow catches up with cylinder piston. This is a characteristic of the hydraulic system and is no sign of a malfunction.

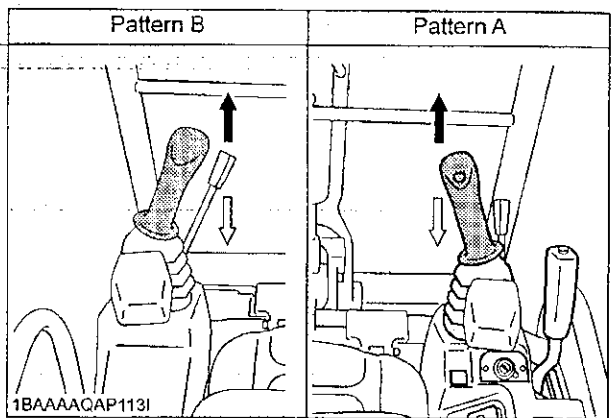

1BAAAAQAP113I

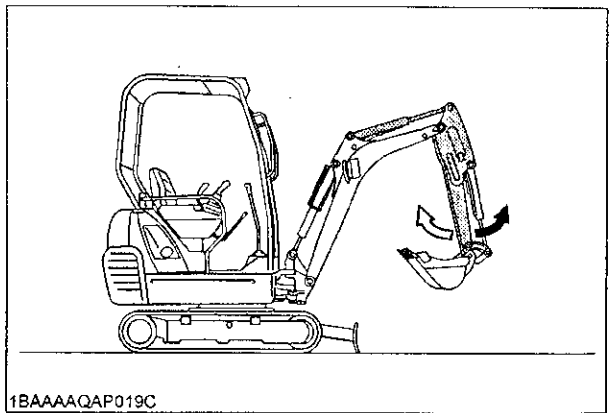

1BAAAAQAP019C

OPERATION OF THE BUCKET

To dig using the bucket, move the right attachment control lever from the neutral position, left. Moving the control lever right, moves the bucket outwards and empties its contents.

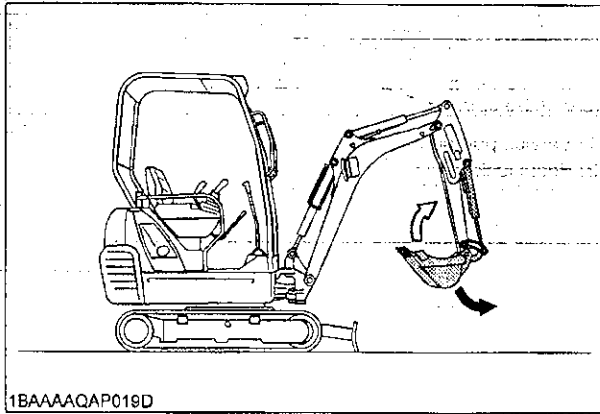
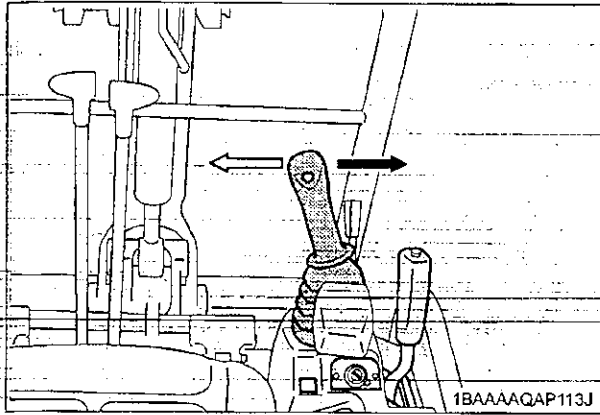

UNIT SWING AND BOOM SWING OPERATION



CAUTION

To avoid personal injury:

- When working in groups, always let the others know what you are going to do before you do it.
- Keep others away from the machine working area.
- Be sure to lock the boom swing pedal when the boom swing function is not used.

■ Unit Swing Operation

1. Move the control lever to the left and the upper structure will turn to the left.
2. Move the control lever to the right and the upper structure will turn to the right.

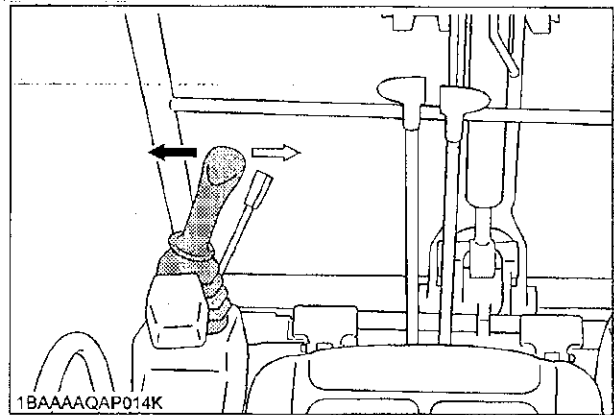

■ Boom Swing Operation

1. Tilt the pedal lock forward to unlock the pedal.
2. Step on the left side of the pedal to swing the boom to the left.
3. Step on the right side of the pedal to swing the boom to the right.

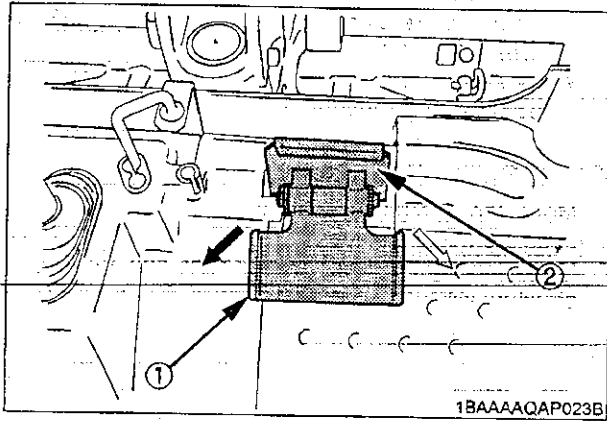

- (1) Boom swing pedal
(2) Pedal lock

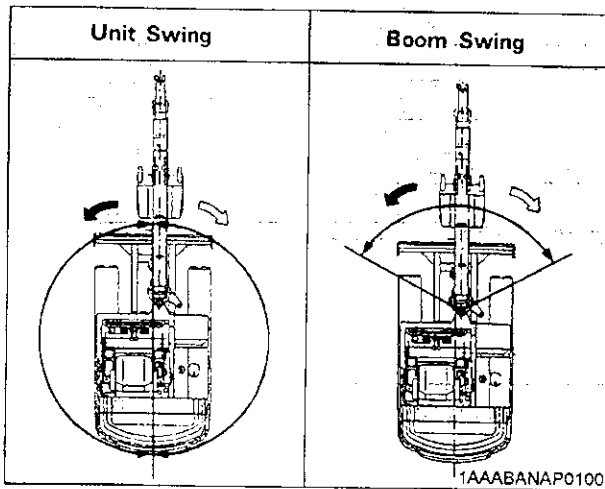

IMPORTANT:

- Do not operate the left attachment control lever abruptly from right to left (or vice versa). Because the low of inertia cause high impact load on the swing gear and the swing motor, shortening the life of the excavator.

SERVICE PORT OPERATION

⚠ CAUTION

To avoid personal injury:

- Tilt the service port pedal forward when the pedal is not used. Be sure to lock the pedal.

This pedal is used to operate hydraulic attachments such as breakers.

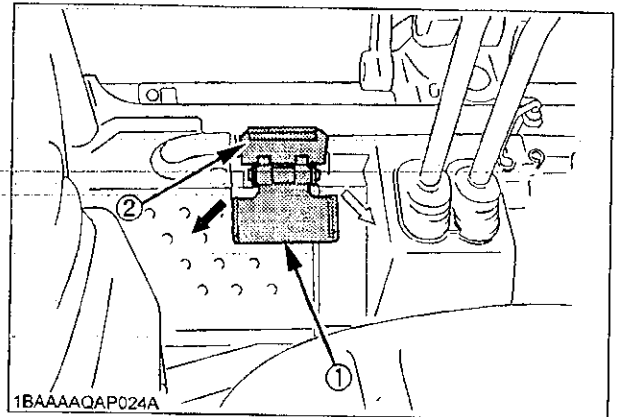

- (1) Service port pedal
(2) Pedal lock

- Push the left part of the pedal (↓), send oil to the pipe (1).
- Push the right part of the pedal (↓), send oil to the pipe (2).

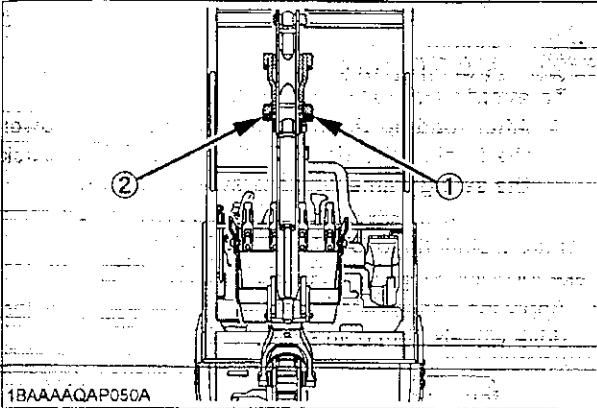

1BAAAQAP050A

Max. Flow Volume (Theoretical L (US. gal)/min.)	27.6 (7.3)
Max. Pressure MPa (kgf/cm ²) [psi]	21.6 MPa (220) [3129]

IMPORTANT :

- When the service port is not used for a long period, dirt particles can settle in the lower part of the service port lines.
When the plugs on the service port lines are removed to connect attachments, drain approx. 3.4 oz (100 cc) of oil per side before making connections.
For breaker choices, contact your dealer.

IMPORTANT INFORMATION ON EXCAVATOR OPERATION

- Do not try to crush concrete or boulders using side swings with the bucket. Also avoid using side sweeps of the bucket to move earth piles.
- Under all circumstances avoid the following operations:
 - Excavation using the gravitational impact of the machine.
 - Compacting of gravel or soil using the dropping action of the bucket.
 - Excavation using the traveling power of the machine.
- Do not try to drop or shake off soil adhering to the bucket in the manner given in the points below. This can cause damage to the machine.

Adhering soil can be shaken off when the bucket is being emptied by moving the bucket out to the maximum stroke of the cylinder. Should this not suffice, swing out the arm as far as possible and operate the bucket back and forth.

- Do not hit the dozer with the boom cylinder!
Make sure that the boom cylinder does not hit the dozer when doing deep excavation. If necessary swing around so that the dozer is in the back of the machine.
- Pay attention when pulling in the bucket!
When pulling in the bucket (for driving or transportation) avoid hitting the dozer.
- Avoid collisions!
When moving the excavator, pay attention that the dozer does not collide with obstructions such as boulders etc..
Such collisions shorten the life of the dozer and the cylinder substantially.
- Support the machine correctly!
When stabilizing the machine with the dozer, lower the dozer to engage the full width on the ground.
- If the water or mud level reaches higher than the top of the tracks, the swivel bearing, swivel motor gear and ring gear may be exposed to mud, water and other foreign objects.
The excavator must be properly pressure washed after each use.
 - Thoroughly clean the area around the swivel bearing, swivel motor gear and ring gear to remove foreign objects.
 - Inspect the swivel motor oil sump (if equipped) for water contamination. If water is present, refer to operator's manual for lubricant replacement procedure.
 - Refer to operator's manual for proper swivel bearing, swivel motor gear and ring gear lubrication procedures.
 - Reinstall any protective covering if removed earlier.

TRANSPORTING THE EXCAVATOR ON A VEHICLE

⚠ DANGER

To avoid personal injury or death:

- No directional changes should be made when the excavator is on the ramp. Should a change of direction be necessary, drive off the ramp completely and make the turn.
- When driving forwards or backwards onto the vehicle, or when swinging the upper body, make sure that neither the CAB or the gates of the vehicle will be damaged.

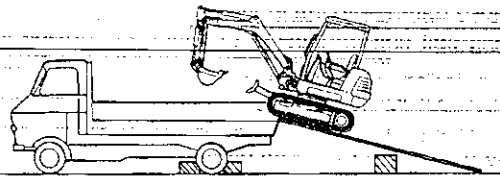

1AAABANAP0080

- When the excavator reaches the point between the ramps and the bed, halt and then move very slowly until the excavator reaches the horizontal position.
- Move the excavator onto the vehicle only with the arm completely pulled in.
- Do not jack up the machine using its boom to load or unload the excavator from the vehicle. Doing this is dangerous.
- Make sure the ramp are of sufficient capacity and securely connected to the vehicle to safely support the machine throughout the loading / unloading operation.

■ Transporting on a truck

⚠ WARNING

To avoid personal injury or death:

- After loading the machine on the truck, lower the bucket and dozer onto the truck bed. Lock the swing frame with the swing lock pin.

Prepare a platform to load or unload the excavator.

Take following steps when using ramps.

1. Apply the parking brakes of the vehicle, and block the drive wheels from both sides.

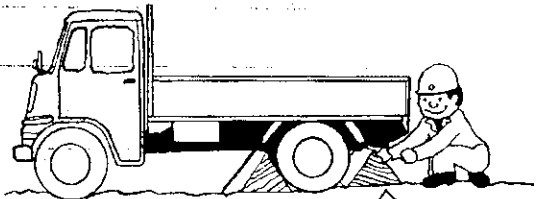

1AAAAADAP001A

2. Use mounting brackets to secure the ramp properly. Connect the ramps directly to the bed.

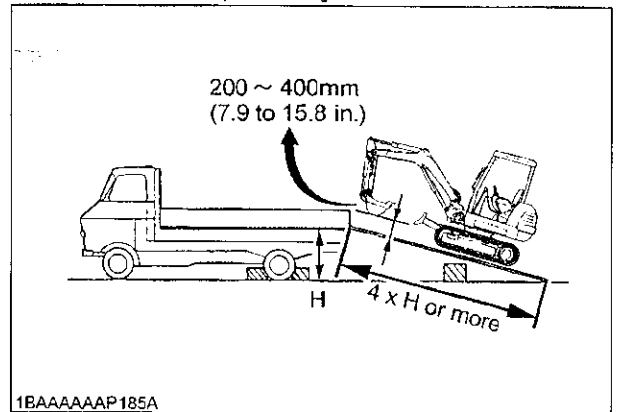

1BAAAAAAP185A

3. For additional safety, use blocks or supports under the ramps and the bed.

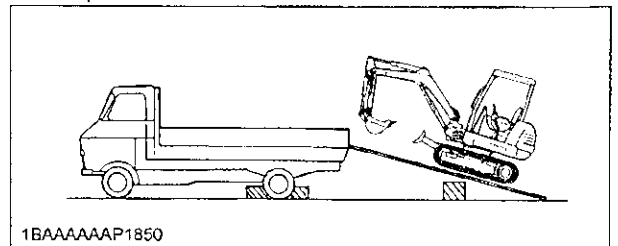

1BAAAAAAP1850

4. Align the ramps and the tracks and then drive the excavator slowly up the ramps with the dozer in the front. After ensuring that the tracks are completely on the bed, swing the upper body around to the back of the vehicle.
5. Block the tracks and cable down the excavator with suitable chains and approved method (check appropriate state regulation).

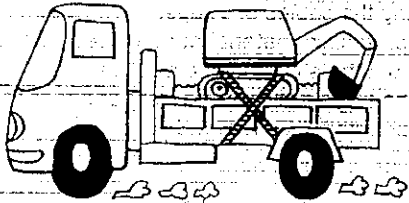

1AAABANAP032A

6. Before unloading, raise the dozer and bucket from the bed.

LIFTING OF THE EXCAVATOR



DANGER

To avoid serious injury or death:

- The correct instructions for safe handling are described here. Read these instructions carefully before moving the machine. Make sure that the operating personnel read the operator's manual carefully.

■ Basics when Lifting with Cables or Straps

1. The lifting and crane operation is to be undertaken according to the safe operation guidelines described.
2. The equipment used for lifting mentioned in these instructions are only given as reference, the standards concerning strength, control and other details are based on the respective applicable guidelines.

■ Safety Aspects when Lifting with Cables or Straps

Abide by following steps when lifting:

1. Do not lift loads that exceed the maximum load capacity of the crane.
2. Choose correct equipment suitable to the weight, size and form of the load.
3. First assess the center of gravity of the load, position the hook directly over the load and lift the load so that the center of gravity of the load is as low as possible.
4. The steel cables or straps must be fixed in the middle of the hook.
5. The load must be lifted vertically from the ground.
6. Do not enter the working area under suspended loads and do not move the load over people. The load must only be moved in an area where the balance can be easily maintained.

■ Lifting Procedure for the Excavator



WARNING

To avoid personal injury or death:

- Do not use the hooks on the roof of canopy and CAB for lifting the excavator.
- Never lift the machine with the angle blade placed at an angle.

◆ General guidelines for lifting

1. Lifting position. (see illustration below)
 - (1) Pull in the boom completely towards the CAB.
 - (2) Pull in the arm completely.
 - (3) Pull in the bucket completely.
 - (4) Adjust the swing angle to the center. (to bring the boom in a position parallel to the machine frame)
 - (5) Swing frame so that dozer blade is to the rear and frame is parallel with tracks.
 - (6) Raise the dozer blade fully.

2. Attaching the steel cables or straps.

- (1) Always hook the excavator at three points. (one on the boom and left and right of the dozer)
- (2) Always use a shackle on each lifting hole when attaching the cables or straps.
- (3) Using protective material at all places where the cables or straps contact the machine.
- (4) Keep the angle between the front and rear cables or straps within 60° (1.05 rad.).

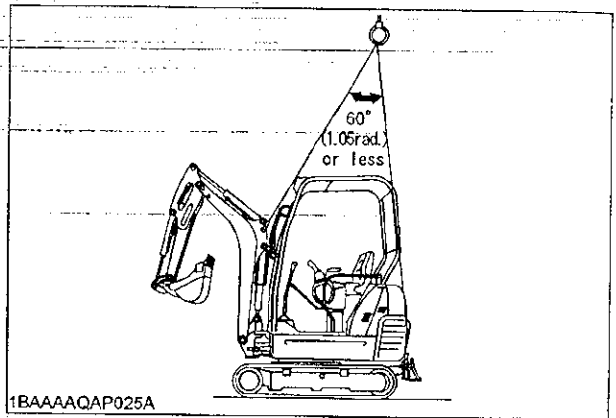

3. Tackle

The weights of the excavators and the recommended tackle for lifting these loads are mentioned in the following table. Choose components having enough strength.

Excavator Weight*	1595 kg (3516 lbs)
Load / Cable	6400 N (1420 lbf)
Minimum Cable Diameter (Safety factor=6)	10 mm (0.4 in.) or more

*Excavator Weight: With long arm.

Steel cable: 6 x 24

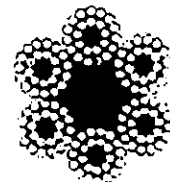

1AAABANAP034A

4. Lifting

- (1) Lift slowly and safely
- (2) Do not enter the excavator area when lifting.
- (3) Lift the excavator horizontally. (Modify cable or strap connections according to needs)

Maximum strength

for example : (JIS G 35 25) - "6 x24"

Diameter	zinc-plated	not zinc-plated.
10 mm (3/8)	45.8 KN(10296 lbf)	49.3 KN(11083 lbf)
12.5 mm (1/2)	71.5 KN(16074 lbf)	77 KN(17310 lbf)
14 mm (9/16)	89.7 KN(20165 lbf)	96.6 KN(21717 lbf)
16 mm (5/8)	117 KN(26303 lbf)	126 KN(28326 lbf)
18 mm (45/64)	148 KN(33272 lbf)	160 KN(35969 lbf)

1. Boom side

Hook in the steel cable with a shackle into the lifting hole.

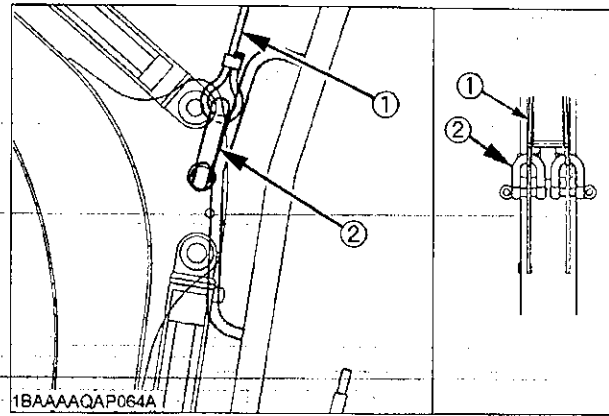

- (1) Steel cable
- (2) Shackle

2. Dozer side

Hook in the steel cable with a shackle into the lifting hole around the canopy.

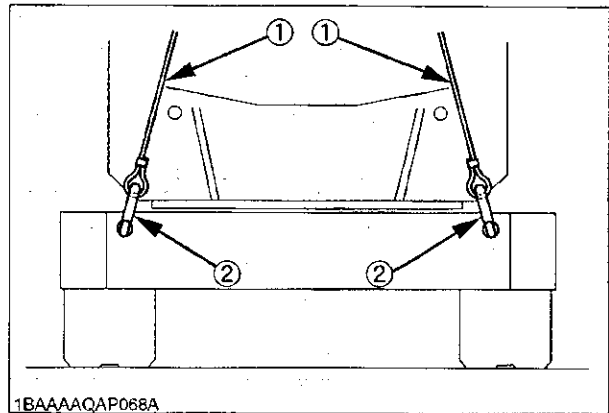

- (1) Steel cable
- (2) Shackle

OPENING AND CLOSING OF PARTS

■ Opening and Closing of the Fuel Tank Cap

1. Open the tank cap cover, insert the starter key and turn counterclockwise. Then turn the tank cap counterclockwise to open.

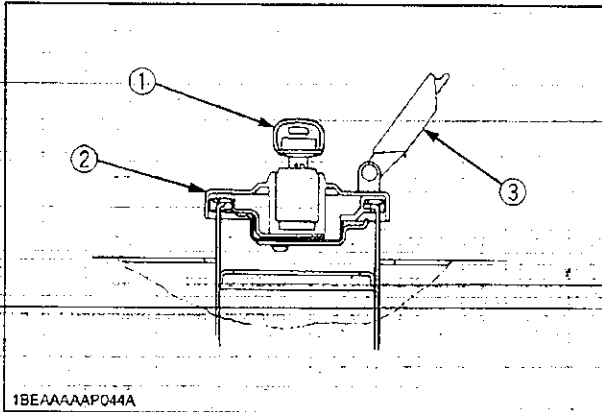

- (1) Starter key
- (2) Fuel tank cap
- (3) Tank cap cover

2. To close the tank cap, turn clockwise and turn clockwise the starter key. Then close the tank cap cover.

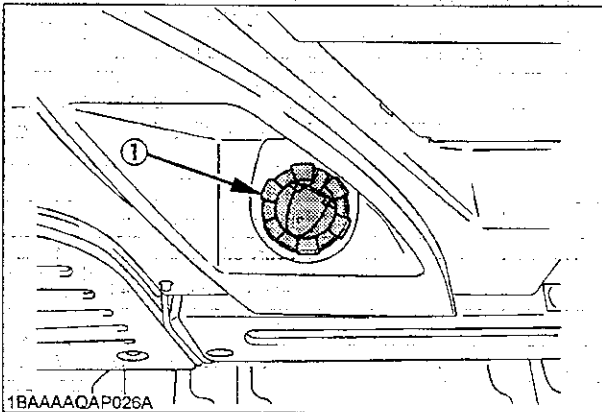

- (1) Fuel tank cap

Insert the key into the key slot and turn it clockwise to open the hood. To close it, lower the bonnet and hold it down tightly. Turn the key counterclockwise to lock the hood.

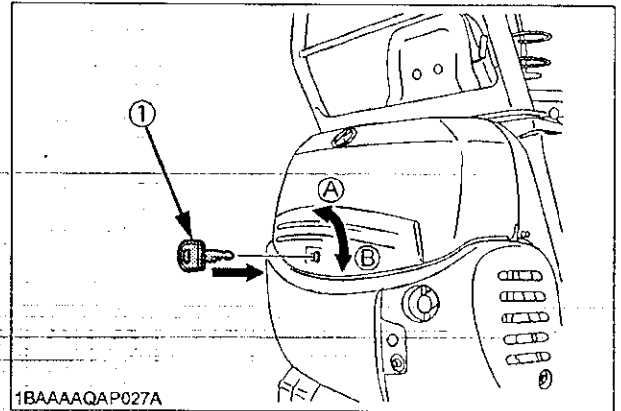

- (1) Key
- (A) "LOCK"
- (B) "UNLOCK"

■ Where to store the Grease Gun

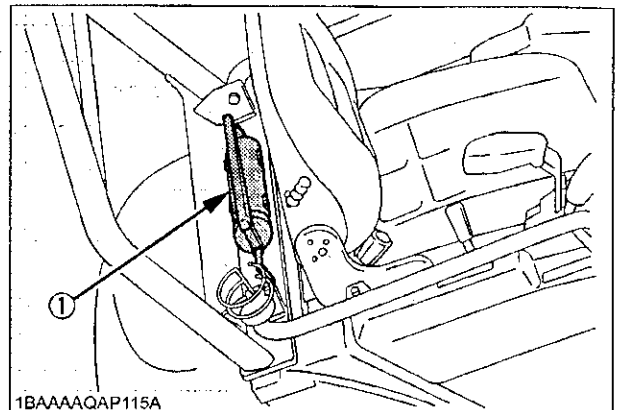

- (1) Grease gun (Option)

■ Opening/Closing of the Engine Hood



CAUTION

To avoid personal injury:

- Do not open the engine hood with the engine running unless in an emergency.
- Do not touch the exhaust muffler or the exhaust pipe; serious burns can occur.

■ Where to keep Operators Manual

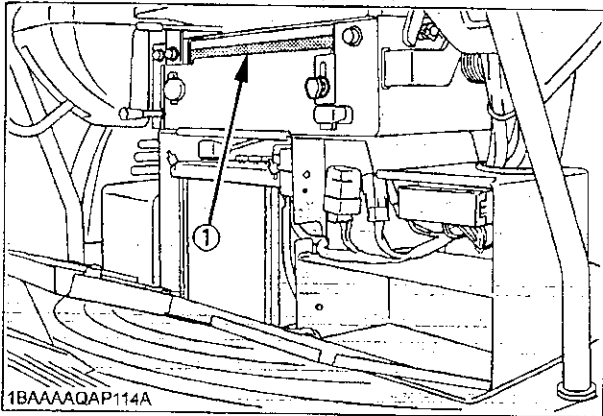

(1) Operator's manual storage

DAILY CHECKS

For your own safety and to assure the long life of your machine, a careful check should be made before each operation.

■ Checking Coolant Level

CAUTION

To avoid personal injury:

- Move the excavator to even ground.
- Make sure that the engine is turned off.
- Do not open the radiator cap right after the engine has been stopped; Serious burns can occur from contact with escaping hot coolant fluid.

- Check the coolant level in the reserve tank only after the engine has cooled down.
- Remove the radiator cap only if absolutely necessary.

1. Check to see that the coolant level is between the "FULL" and "LOW" marks of a reserve tank.
2. When the coolant level drops due to evaporation, add water only up to the full level.

In case of leakage, add anti-freeze and water in the specified mixing ratio up to the full level.
(See "Changing Radiator Coolant " in every 2 years maintenance.)

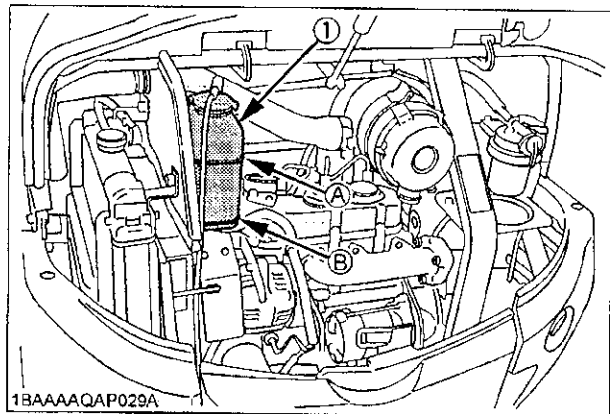

(1) Reserve tank

(A) "FULL"

(B) "LOW"

IMPORTANT :

- Do not fill the reserve tank over the "FULL" marking.
- Do not fill with dirty or salty water.

■ Checking Fuel Level



CAUTION

To avoid personal injury:

- Stop the engine and remove the key before fuelling.
- Do not smoke while fuelling.

IMPORTANT :

- By temperatures over -5°C (23°F), use No.2-D diesel fuel, when temperatures are under -5°C (23°F), use No.1-D diesel fuel.
- Make sure that the fuel tank is not run empty. Air will enter the fuel system, and must be purged before restarting.
- See "PURGING OF THE FUEL SYSTEM" in "OTHER ADJUSTMENTS AND REPLACEMENTS"
- To prevent condensation (water) accumulations in the fuel tank, fill the fuel into the tank before parking overnight.

1. Check the fuel level by the fuel level indicator.

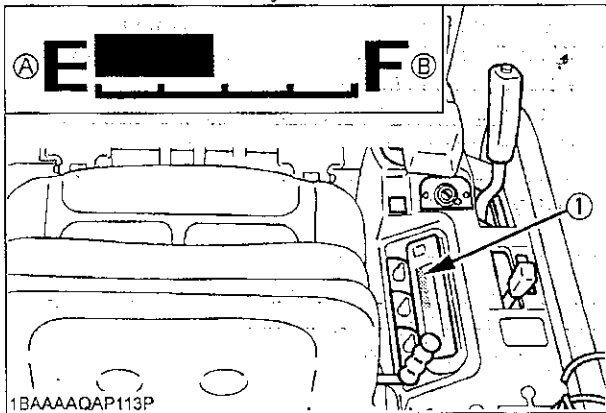

(1) Fuel gauge

(A) "EMPTY"
(B) "FULL"

2. Open the tank cap with the starter key, and add fuel.
 - See "Opening and Closing of the Fuel Tank Cap" and see "LCD Display for Normal Operation".

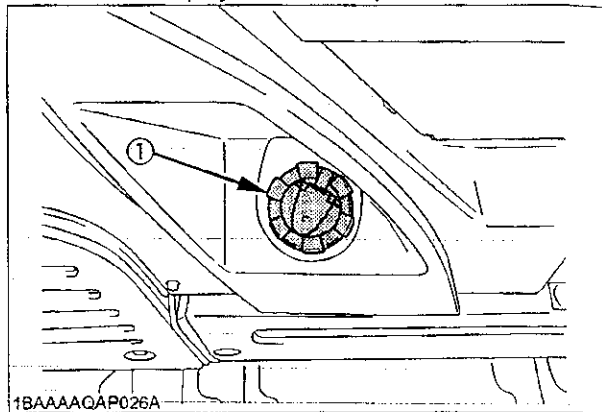

(1) Fuel tank cap

■ Checking Engine Oil Level



CAUTION

To avoid personal injury:

- Stop the engine and remove the key before checking the oil level.

IMPORTANT :

- Use engine oil with the correct viscosity. (according to the outside temperature)
- After stopping the engine and remove the key, wait five minutes, then check oil level. (Excavator must be on level ground.)

Insert the engine oil dipstick fully into the respective port opening, remove again and check the oil level; if necessary fill with oil. The machine must be on level ground when checking the oil level.

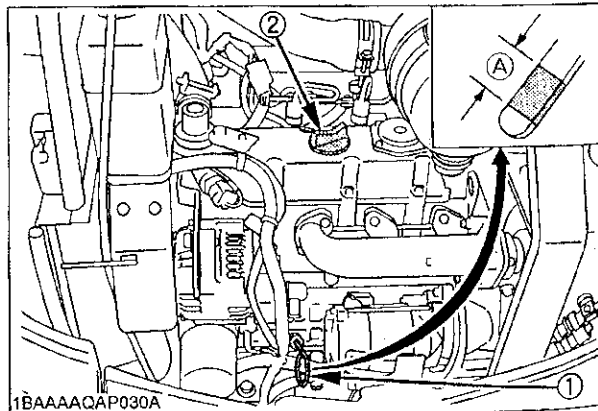

(1) Engine oil dipstick
(2) Filling port

(A) Oil level is acceptable within this range.

■ Checking Hydraulic Oil Level

⚠ CAUTION

To avoid personal injury:

- Stop the engine and remove the key before checking the oil level.

IMPORTANT:

- Before filling oil, wipe away all sand and dust from around the oil port. Make sure to use an identical type of hydraulic fluid.
 - The excavator has been filled with hydraulic fluid before delivery. See "RECOMMENDED OILS". (Do not mix different oils.)
1. Park the excavator on a firm, flat and level surface. Lower the attachments and dozer blade to the ground and stop the engine.

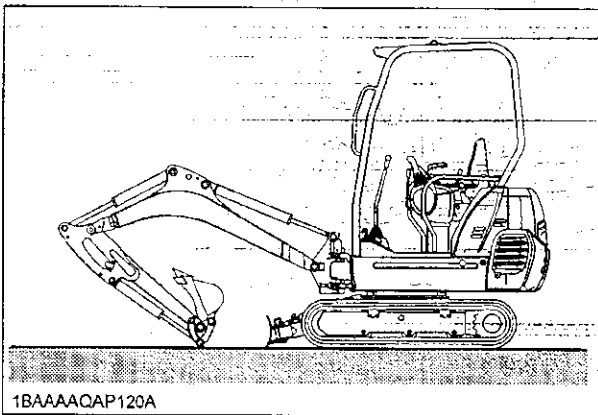

1BAAAAQAP120A

2. Check the oil level as to whether it lies on the center of the gauge at normal temperature (10 to 30°C (50 to 80°F)).
3. Enough oil is present if the oil level lies near the center of the gauge.
4. Should the oil level be too low, fill oil through the oil port before starting the engine. This step is important for the protection of the hydraulic system.

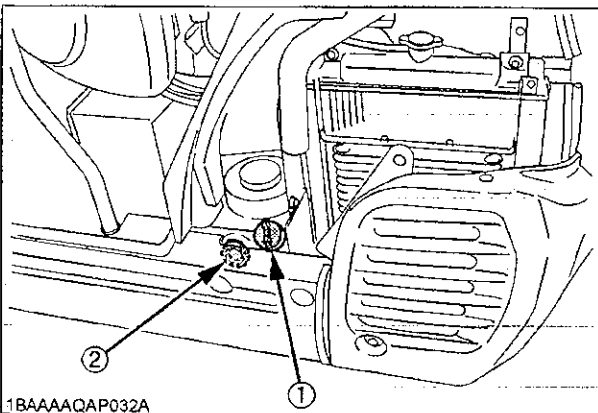

1BAAAAQAP032A

- (1) Tank cap
- (2) Gauge

■ Lubrication Points

⚠ CAUTION

To avoid personal injury:

- First lower all attachments to the ground then stop the engine and remove the key.
- While greasing, take caution not to step on the bucket teeth.
- When doing excavation work in water, generously grease the following points. After ending work, grease again.

Grease the marked grease nipples shown by arrows in the illustration below.

1. Boom bottom linkage..... 1 place
2. Arm bottom linkage..... 1 place
3. Bucket link pin..... 3 places
4. Boom cylinder boss..... 2 places
5. Arm cylinder boss..... 2 places
6. Bucket cylinder boss..... 1 place
7. Fixing pin between arm and bucket..... 1 place
8. Boom swing fulcrum..... 1 places
9. Swing cylinder bottom..... 1 place
10. Swing pin..... 2 place
11. Dozer cylinder boss (or pin)..... 2 places
12. Dozer linkage pin..... 2 places

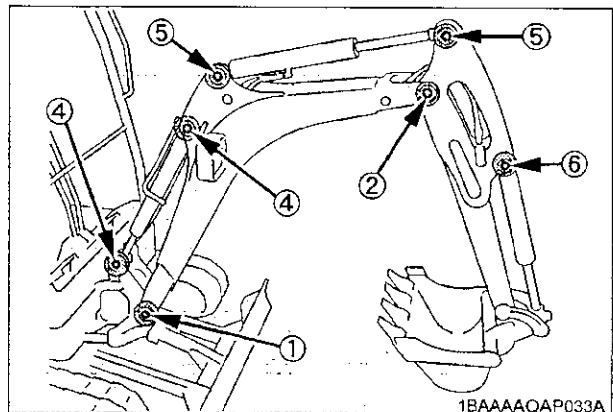

1BAAAAQAP033A

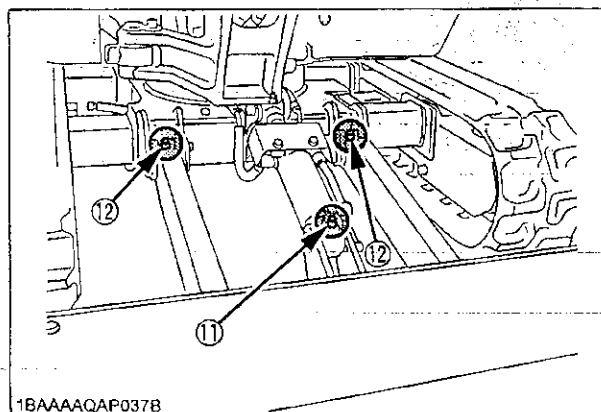
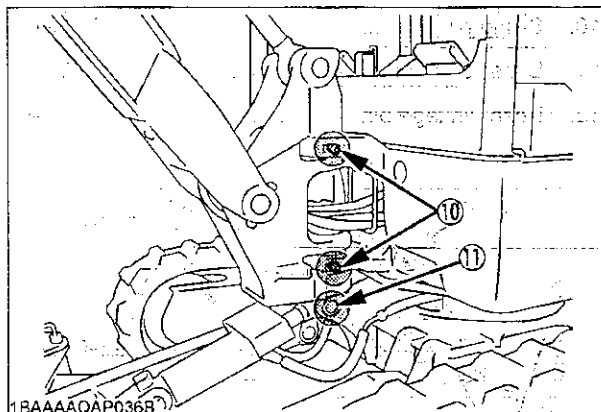
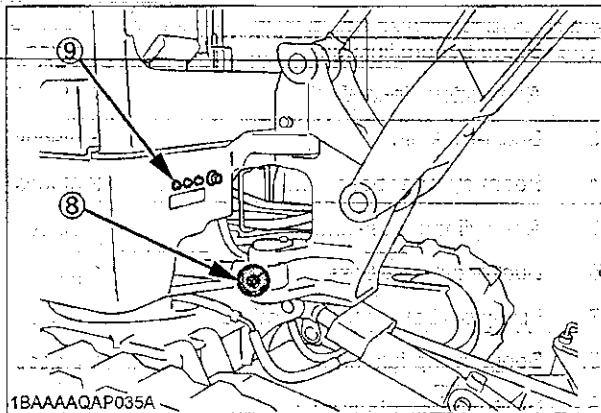
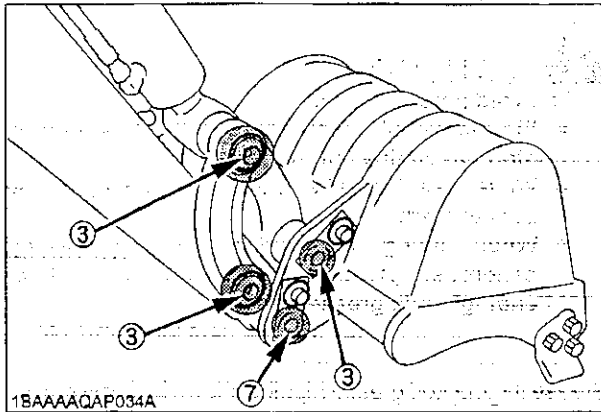

■ Checking Radiator and Oil Cooler

CAUTION

To avoid personal injury:

- Always stop the engine and remove the key before checking the radiator.
- Wear eye protection when cleaning with compressed air.

1. Check if the fins and ribs are clogged. If so clean with compressed air or steam.
- 2.- Check the rubber hoses for damage and replace if cracked or old. Check if the hose clamps are tight enough.



(1) Oil cooler

IMPORTANT :

- Radiator and oil cooler fins and ribs must be clean in order not to overheat the engine and allow free flow of air through the cooling elements.
- Pressure of compressed air must be under 205 kPa (2.1 kgf.cm², 30 psi)

■ Checking and Cleaning Engine and Electrical Wiring



CAUTION

To avoid personal injury:

- Always stop the engine and remove the key before cleaning the wiring, cables and engine.

Before starting, check whether flammable substances have gathered on the battery, the cables and wiring, the muffler or on the engine. Remove thoroughly.

Check the electrical circuitry for disconnections, shorts or loose terminals.

■ Washing Whole Machine

IMPORTANT :

- Do not wash the excavator with the engine running. Water could enter the air filter and damage the engine. Make sure that the air filter is kept dry.
- Remove the mud before washing the machine.

REGULAR CHECKS AND MAINTENANCE WORK

EVERY 50 SERVICE HOURS

■ Draining Fuel Tank



CAUTION

To avoid personal injury:

- Before draining the fuel tank, be sure to stop the engine and remove the key.
- Do not smoke during inspection.

1. Remove the drain plug on the underside of the body and drain water.
2. Re-tighten the drain plug.

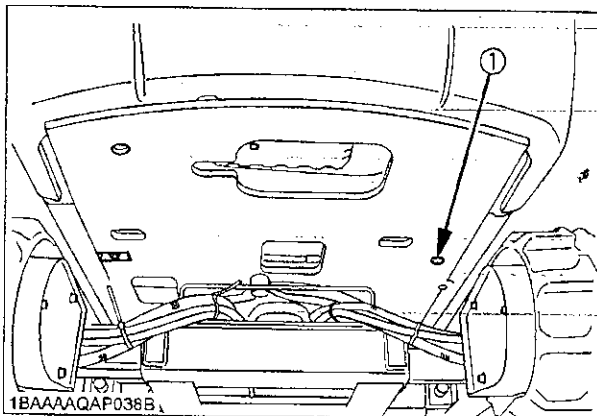

(1) Drain plug

■ Draining Fuel Filter

1. Open the hood.
2. When the separated water is being drained, the red float moves upwards. When the float reaches the filter element, close the cock so that no fuel can run out. Now loosen the ring nut, and remove the cup and empty completely.
3. Clean carefully not to damage the filter element.
4. Finally, do not forget to open the cock and fix the left side cover.

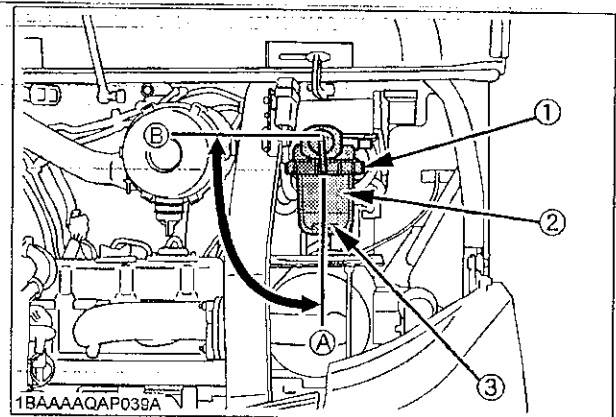

(1) Ring nut

(3) Float

(A) "Open"

(2) Filter element

(B) "Closed"

■ Battery



DANGER

To avoid the possibility of a battery explosion:

For refillable type battery, follow the instructions below.

- Do not use or charge the refillable type battery if the fluid level is below the LOWER (lower limit level) mark. Otherwise, the battery component parts may prematurely deteriorate, which may shorten the battery's service life or cause an explosion. Check the fluid level regularly and add distilled water as required so that the fluid level is between the UPPER and LOWER levels.



CAUTION

To avoid personal injury:

- Never remove the vent caps while the engine is running.
 - Keep electrolyte away from eyes, hands and clothes. If you are splattered with it, wash it away completely with water immediately and get medical attention.
 - Wear eye protection and rubber gloves when working around the battery.
 - Before inspection or dismantling the battery, be sure to turn off the engine and turn the starter switch to the "OFF" position.
 - When removing the battery, always disconnect the negative ground cable first. When installing a battery, always connect the ground cable last. This prevents a possible explosion caused by sparks.
 - Always wear eye protection when working with the battery.
1. Remove the battery from the storage and check the battery fluid level and add distilled water if necessary. Open the side hood, check the battery fluid level and add distilled water if necessary.
 2. Clean the battery caps (ventilation holes) also.

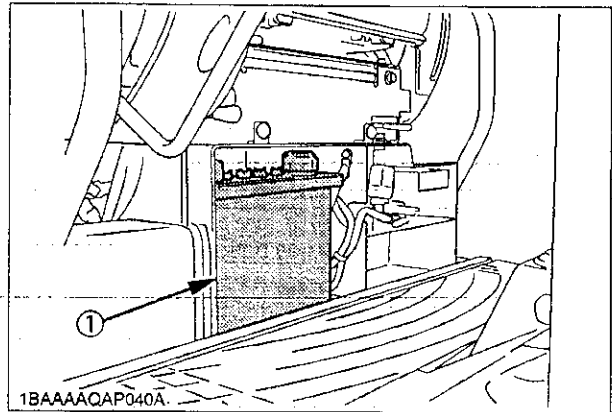

(1) Battery

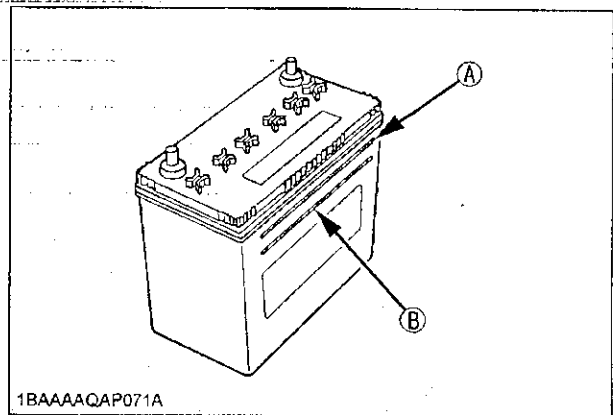

(A) "UPPER LEVEL"
(B) "LOWER LEVEL"

Battery Charging



CAUTION

To avoid personal injury:

- When the battery is being activated, hydrogen and oxygen gases in the battery are extremely explosive. Keep open sparks and flames away from the battery at all times, especially when charging the battery.
 - When charging battery, make sure battery vent plugs are securely.
 - When disconnecting the cable from the battery, start with the negative terminal first. When connecting the cable to the battery, start with the positive terminal first.
 - Do not check battery charge by placing a metal object across the terminals. Use a voltmeter or hydrometer.
1. Make sure each electrolyte level is to the bottom of vent wells. If necessary, add distilled water in a well-ventilated area.

2. The water in the electrolyte evaporates during recharging. Liquid shortage damages the battery. Excess liquid spillage damages the excavator.
3. To slow charge the battery, connect the battery positive terminal to the charge positive terminal and the negative to the negative, then recharge in the standard fashion.
4. A boost charge is only for emergencies. It will partially charge the battery at a high rate and in a short time. When using a boost-charged battery, it is necessary to recharge the battery as early as possible. Failure to do this will shorten the battery's service life.
5. When the specific gravity of electrolyte falls between 1.27 and 1.29 charge has completed.
6. When exchanging an old battery for a new one, use a battery of equal specification.

■ Greasing Swing Bearing Teeth

1. Pump grease with grease gun through the grease nipple (at the right end side).
2. Grease at each 90° (1.58 rad.) position of the swing frame.
3. Fill with approx. 50g of grease (approx. 20 to 30 pumps with the grease gun at each position).

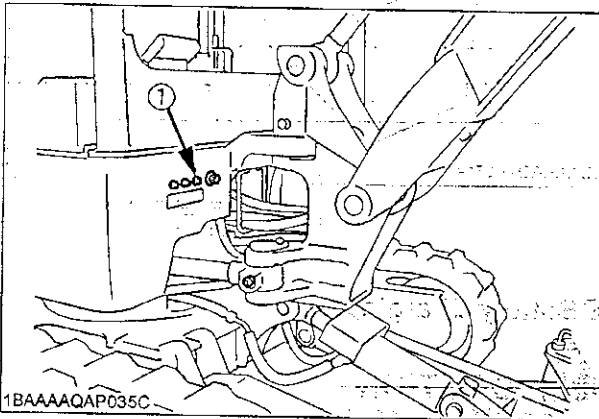

(1) Grease nipple

EVERY 200 SERVICE HOURS

Do all 50-hour servicing at the same time.

■ Checking Fan Belt Tension

◆ Check and adjustment of the fan belt tension



CAUTION

To avoid personal injury:

- First stop the engine and remove the key.
- After servicing, make sure to replace the belt cover in its original position.

1. Press the fan belt down in the middle, with a force of approx. 10 kg (22 lbs.). The belt tension is correct if it deflects about 8 mm (0.31 in). If otherwise, loosen bolt (1) shift the alternator (2) in the direction shown by the arrow.
2. Replace the fan belt if worn out, cracked or torn.

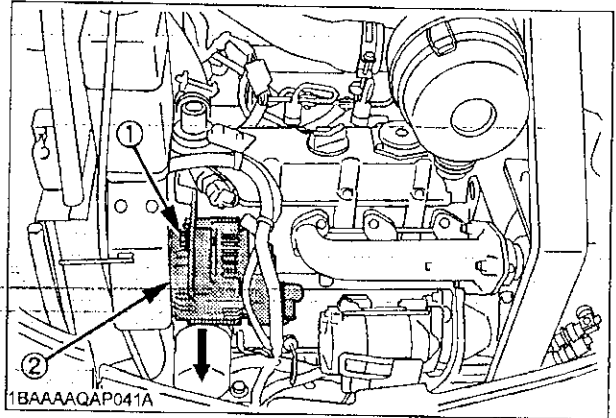

1BAAAQAP041A

- (1) Bolt
(2) Alternator

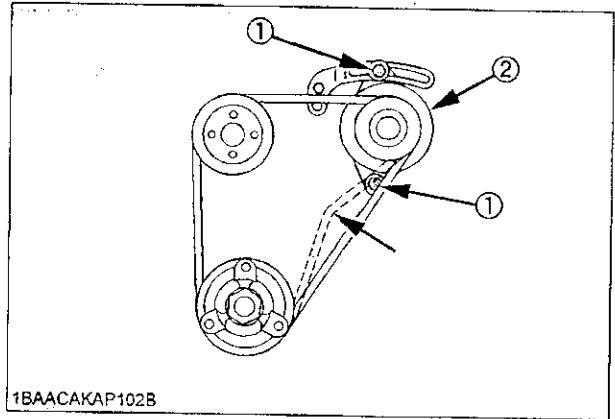

1BAACAKAP102B

- (1) Bolt
(2) Alternator

IMPORTANT :

- If the engine is run with a loose fan belt, the belt could slip and cause overheating of the engine or insufficient battery charging. Check fan belt tension regularly.
- Should the fan belt break or jump off, the Indicator light for battery charge will light up. Stop the engine and remove the key immediately.

■ Checking Radiator Hoses and Clamps



CAUTION

To avoid personal injury:

- Wait long enough for the radiator coolant to cool down.

Check the water hoses for proper connection. This check should be carried out every 200 hours or every 6 months, whichever comes first.

1. Should the hose clamps become loose or water leaks, tighten the hose clamps properly.
2. Should the radiator hoses become swollen, aged or cracked, they must be replaced and the hose clamps tightened again properly.

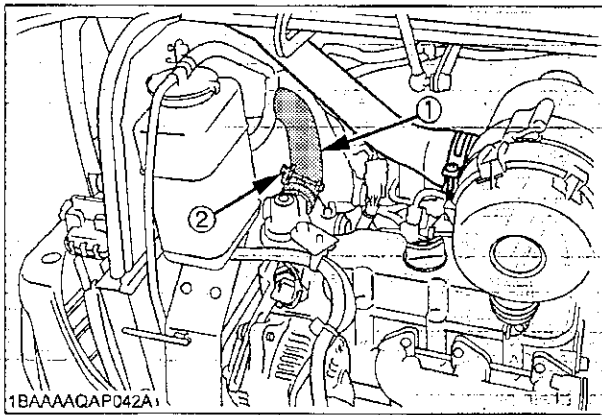

(1) Radiator hoses (2) Hose clamps

■ Inspection and Cleaning Air Filter Element

Open the engine cover and remove the dust cover. Take out only outer element, clean the element, case interior and reassemble. During reassembly, take care to install the dust cover with facing the TOP mark upwards. Do not remove the inner element (safety element).

IMPORTANT :

- Should the machine be used in extreme dusty areas, the air filter element must be inspected and cleaned more frequently than in the specified maintenance periods.
- The air filter has a dry element, keep free from oil.
- Do not run the engine without the air filter.

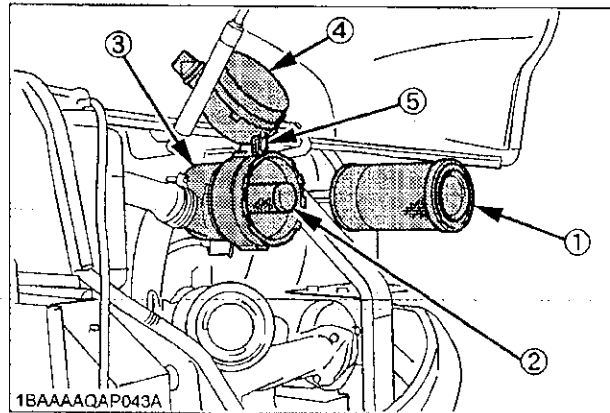

(1) Outer element
(2) Inner element (safety element)
(3) Case
(4) Dust cover
(5) Clamps

■ Air Filter Maintenance



CAUTION

To avoid personal injury:

- Wear eye protection.

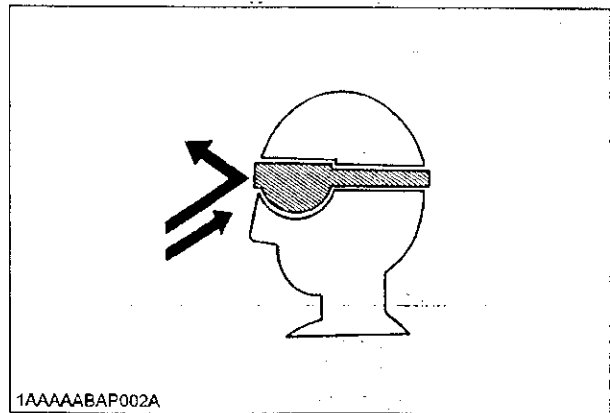

The quickest and safest method of maintenance is the exchange of the paper cartridge. Furthermore there are different methods of cleaning the cartridge.

◆ **Cleaning with compressed air**

Pressure of compressed air must be under 205 kPa (2.1 kgf/cm², 30 psi), and the cartridge should be blown clean from the inside to the outside until the dust deposits are noticeably reduced.

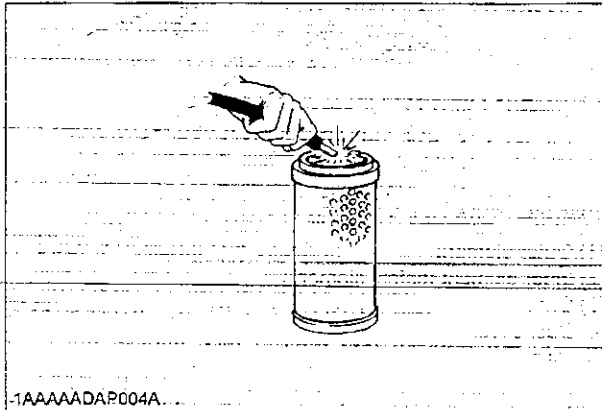

IMPORTANT :

- If the air suction is still inadequate, or the color of the exhaust gases is abnormal even after the cleaning, the air filter cartridge must be replaced.

■ **Greasing Swing Bearing**

1. Fill with grease through the respective grease nipple.
2. Grease at each 90° (1.58 rad.) position of the swing frame.

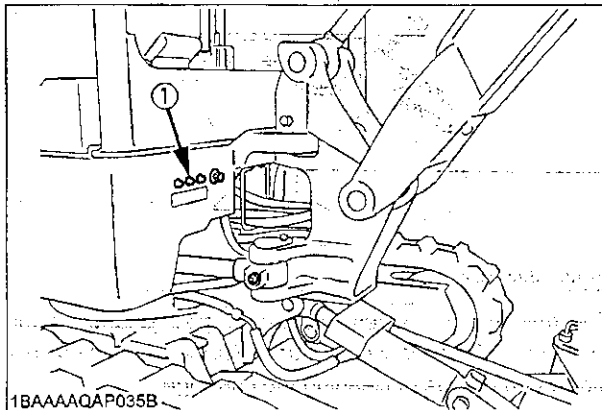

(1) Grease nipple

■ **Checking Fuel Line and Intake Air Line**

1. Check to see that all lines and hose clamps are tightened and not damaged.
2. If hoses and clamps are found worn or damaged, replace or repair them at once.

EVERY 250 SERVICE HOURS

Do all 50 hour servicing at the same time.

■ **Changing Engine Oil (First Engine Oil Change after 50 Service Hours)**

CAUTION

To avoid personal injury:

- First stop the engine then remove the key and wait long enough for the oil to cool down.

1. Remove the drain plug on the underside of the engine and drain all oil.
2. Re-tighten the drain plug.

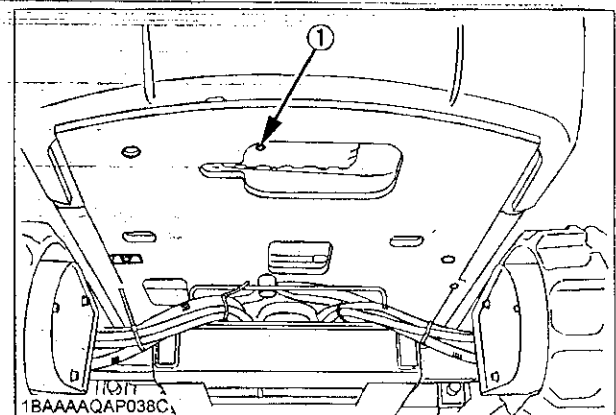

(1) Drain plug

3. Fill through the filling port up the specified level.

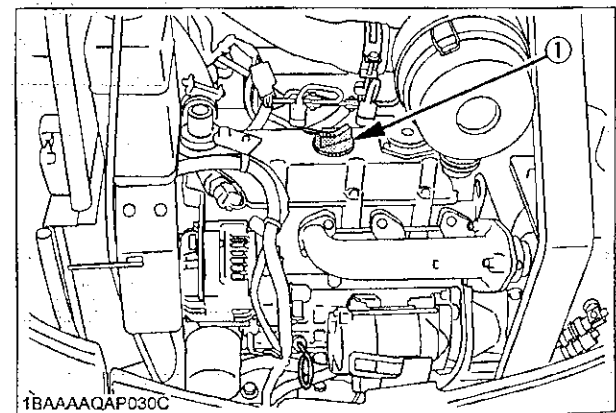

(1) Oil filling port

4. Let the engine idle for approx. 5 min. Check the engine oil level. To check the engine oil level, insert the engine oil dipstick completely into the respective port opening and pull out again. If the oil level lies between both markings, no oil must be added.

IMPORTANT :

- Regardless of the service hours, an engine oil change is due every six months.

■ Replacing Engine Oil Filter

1. Replace the oil filter cartridge at the same time as doing the engine oil change.
2. Remove the cartridge with the supplied filter wrench.

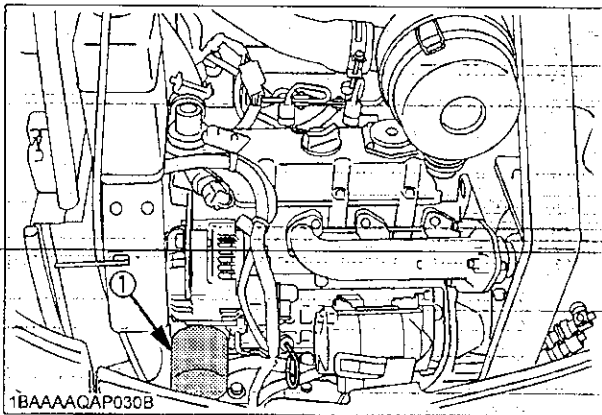

(1) Oil filter

3. Oil the O-ring of the new oil filter cartridge lightly. Then tighten the oil filter cartridge by hand.
4. Fill engine oil to the specified level.
5. Let the engine run for approx. 5 min. and make sure that the engine oil indicator lamp does not light up. Then stop the engine and remove the key.
6. The engine oil level is reduced by the amount of the filter capacity after the engine is started. It is necessary to add oil.

IMPORTANT :

- Always check the oil level after having exchanged the filter.

Engine oil volumes (with engine oil filter)	3.6L (0.951 US gal.)
--	-------------------------

EVERY 500 SERVICE HOURS

Do all 50 and 250 hour servicing at the same time.

■ Drive unit Oil Change(First Oil Change at 100 hours)



CAUTION

To avoid personal injury:

- Lower to the ground, stop the engine and remove the key before undertaking the oil change.

1. Rotate the track so that the drain plug of the drive unit is in the bottom position.
2. Remove the drain plug to let the oil run out. Screw in and tighten the drain plug again and fill with gear oil through the oil check port.
3. Fill oil until it overflows out of the oil check port.

Oil change

- first oil change after 100 hrs
- then every 500 hrs
- or at least once a year

4. Use prescribed gear oil SAE 90.

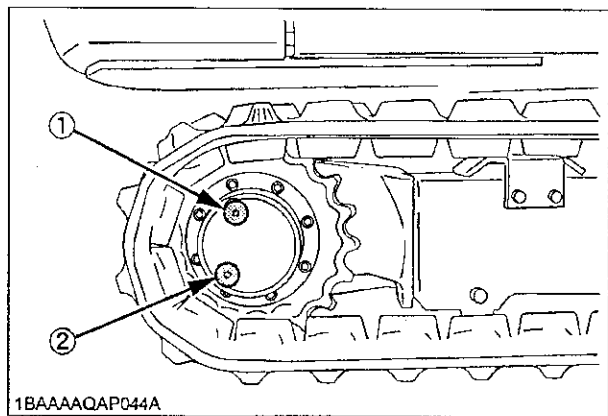

(1) Drain plug
(2) Oil filling port

Gear oil volume	approx. 0.25L (0.066 US gal.)
-----------------	----------------------------------

■ Replacing Fuel Filter Element



CAUTION

To avoid personal injury:

- Keep fire away.

1. Close the cock of the fuel filter. Remove the filter with the supplied filter wrench.

2. Apply a light film of fuel to the seal of the new filter and turn in tightly by hand.
3. Open the cock of the fuel filter again.

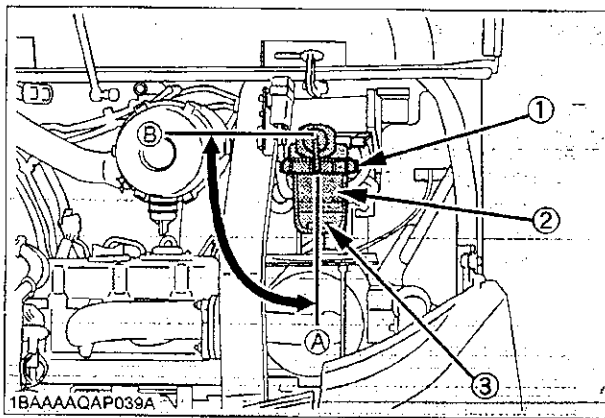

- (1) Ring nut (3) Float (A) "Open"
 (2) Filter element (B) "Closed"

IMPORTANT :

- After exchange of the filter, the fuel system must be purged of air.

■ Replacing Hydraulic Return Filter Element (first replacement after 250 service hours)



CAUTION

To avoid personal injury:

- Remove the oil filter only after the oil in the hydraulic tank has cooled down.

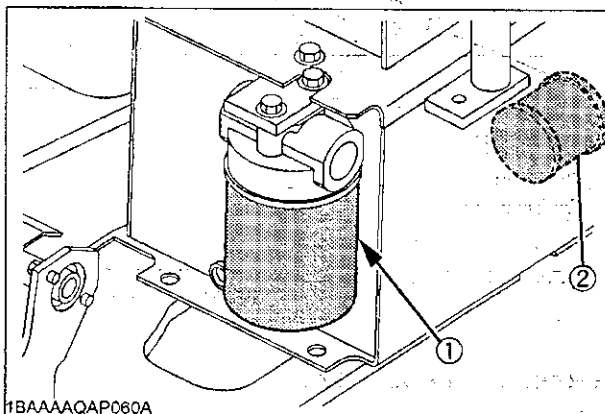

- (1) Return filter cartridge
 (2) Suction filter

1. Replace the oil filter cartridge at the same time as doing the hydraulic oil change.
2. Remove the cartridge with the supplied filter wrench.
3. Oil the O-ring of the new oil filter cartridge lightly. Then tighten the oil filter cartridge by hand.

4. Fill hydraulic oil to the specified level.

IMPORTANT :

- Always check the oil level when replacing the filter.

EVERY 1000 SERVICE HOURS

Do all 50, 200, 250 and 500 hour servicing at the same time.

■ Hydraulic Oil Check for Machines with Hydraulic Breakers

The hydraulic oil change after 1000 operating hours in the operator's manual is based on the type of work done. Following inspection measures are valid when hydraulic breakers are used:

1. Changing and filling up of hydraulic oil
 - (1) The hydraulic oil must be changed more often when breakers are used because the machine is subject to harder conditions than normal excavating work.
 - (2) Use only the recommended oils mentioned in the operator's manual when changing or filling with oil.
 - (3) When filling up oil, never mix oils of different makes.
2. Changing the return filter and oil
 - (1) The filter must be changed more often because of contamination resulting from the frequent assembly and disassembly of the hoses.
 - (2) Use the correct replacement filter.
 - (3) Oil change according to operating hours.

	Hydraulic oil	Return Filter	Suction Filter
Normal excavator work	every 1000 Hrs.	500Hrs. (250Hrs. after first operation)	1000 Hrs.
Breaker work portion	20%	evry 800 Hrs.	
	40%	evry 400 Hrs.	
	60%	evry 300 Hrs.	
	More than 80%	evry 200 Hrs.	

Hydraulic Oil Change (Including Replacing Suction Filter in Hydraulic Tank)



CAUTION

To avoid personal injury:

- Wait long enough for the hydraulic fluid to cool down. Then begin with the change of the hydraulic fluid.

1. Park the excavator on a firm, flat and level surface. Lower the attachments and dozer blade to the ground and stop the engine.

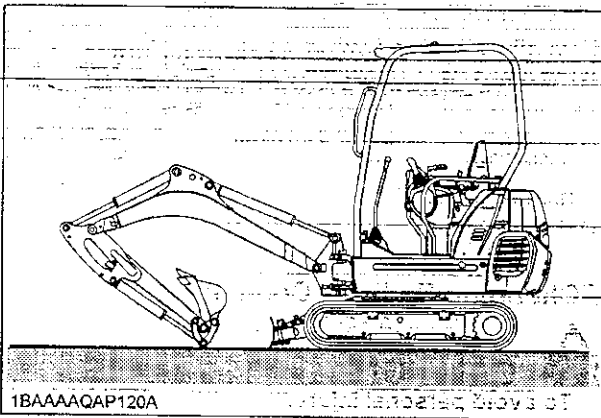

2. Remove the drain plug on the underside of the hydraulic tank and drain the oil.

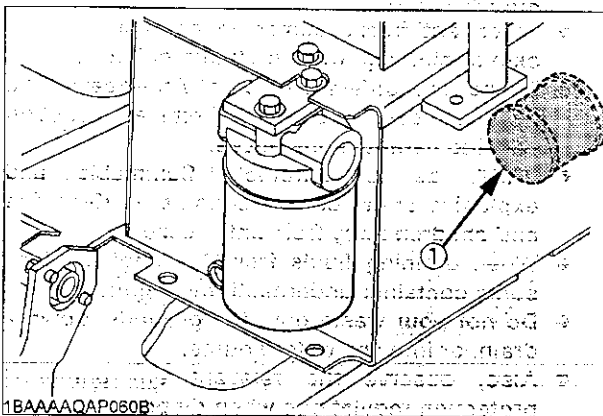

(1) Suction filter

3. Remove the cover of the hydraulic tank
4. With a fork wrench or similar, remove and replace the filter with new one.
5. Retighten the drain plug, and remove iron powder adhering to the magnet.
6. Fill oil through the oil-filling opening on the top side of the tank.
7. Let the engine run for approx. 5 min. and check the oil level again.

IMPORTANT :

- Should dirt deposits be in the hydraulic tank, remove with the help of a clean cloth and light oil.

Hydraulic oil volumes	Hydraulic tank	14L (3.699 US gal.)
	Whole oil volumes	27L (7.133 US gal.)

EVERY 1000 SERVICE HOURS OR ONCE A YEAR

Replacing Air Filter Element

Open the engine cover and remove the dust cover.

Take out outer element and inner element (safety element).

Replace inner and outer element.

Installing the dust cover, be sure to its TOP mark (arrow) faces upwards.

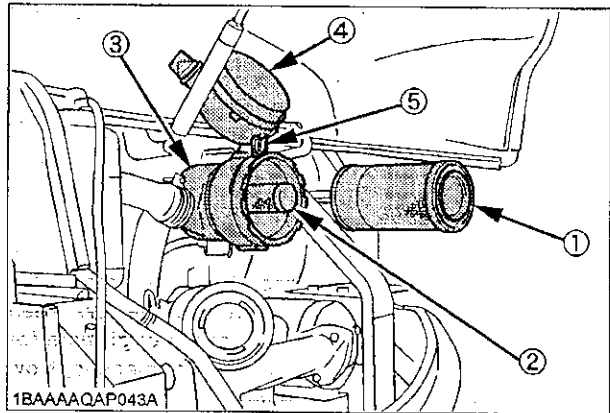

- (1) Outer element
- (2) Inner element (Safety element)
- (3) Case
- (4) Dust cover
- (5) Clamps

IMPORTANT :

- Shorten the replacement period if using in a place exposed to lots of dust or sandy areas.

EVERY 1500 SERVICE HOURS

■ Checking Fuel Injection Nozzle (Injection Pressure)

Consult your local KUBOTA Dealer for this service.

EVERY 2000 SERVICE HOURS

Do all 50, 200, 250, 500 and 1000 hour servicing at the same time.

■ Changing Front Idler and Track Roller Oil

NOTE:

- Contact your KUBOTA dealer for details.

■ Checking Alternator and Starter Motor

NOTE:

- Contact your KUBOTA dealer for details.

EVERY 3000 SERVICE HOURS

■ Checking Injection Pump

Consult your local KUBOTA Dealer for this service.

ANNUAL SERVICE

■ Electrical Wiring and Fuses

Check the terminals periodically for proper connections. Loose wiring or damaged cables can cause improper functioning or short circuiting of the electrical system. Check wiring and replace damaged components immediately. If a fuse blows out soon after having been replaced, contact your nearest KUBOTA dealer. Do not use a fuse other than specified.

BIENNIAL SERVICING



CAUTION

To avoid personal injury:

- Do not loosen the radiator cap before the radiator has cooled down sufficiently. Then only loosen the cap and allow enough time for the pressure in the system to be released. Now remove the cap completely.

■ Replacing of Radiator Hoses

Replace radiator hoses and hose clamps every two years. If the hoses are swollen, hard or cracked, they must be replaced earlier.

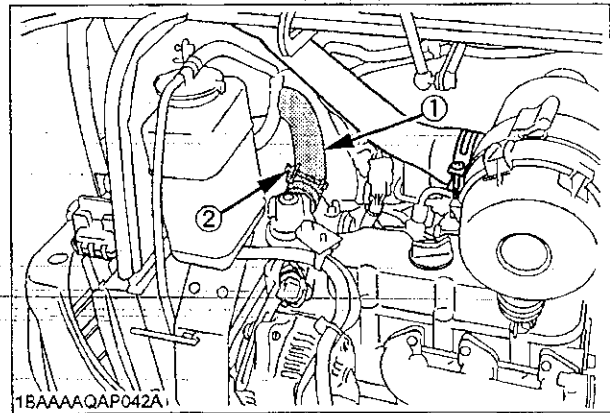

- (1) Radiator hoses
(2) Hose clamps

■ Changing Radiator Coolant



CAUTION

To avoid personal injury:

- When using anti-freeze, put on some protection such as rubber gloves (Anti-freeze contains poison.).
- If anti-freeze has been swallowed, seek medical attention at once.
- When anti-freeze comes in contact with the skin or clothing, wash it off immediately.
- Do not mix different types of Anti-freeze. The mixture can produce chemical reaction causing harmful substances.
- Anti-freeze is extremely flammable and explosive under certain conditions. Keep fire and children away from anti-freeze.
- When draining fluids from the engine, place some container underneath the engine body.
- Do not pour waste onto the grounds, down a drain, or into any water source.
- Also, observe the relevant environmental protection regulations when disposing of anti-freeze.
- Anti-freeze if swallowed is poison to people, animals and birds.

Stop the engine then remove the key and wait until it has cooled down completely.

1. Open the drain plug on the bottom of the radiator and drain coolant completely. Should a reserve tank be equipped, disconnect the line from the tank floor and then open the drain cock.
2. To clean, rinse the radiator with water.
3. Close the drain plug and fill the radiator and the reserve tank with coolant fluid. Let the engine idle for about 5 min., cut the engine and remove the key then check the coolant level.
4. The machine has been shipped filled with 50% anti-freeze solution.

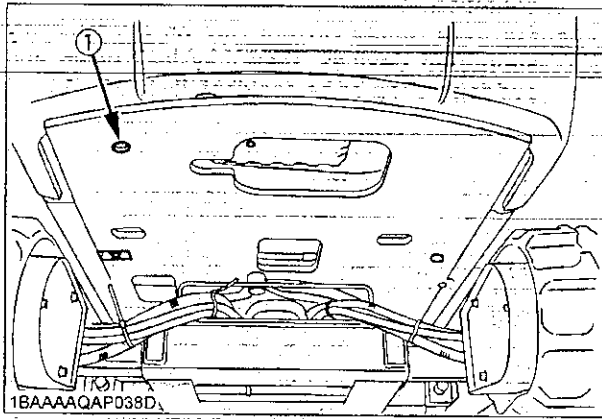

(1) Drain plug

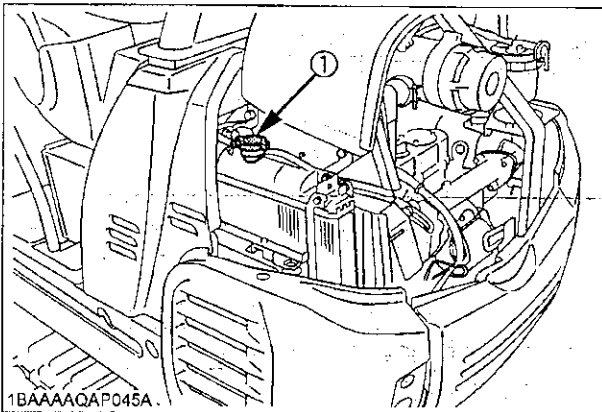

(1) Radiator cap

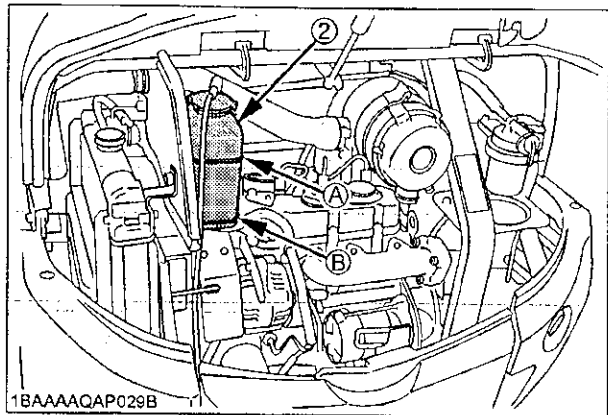

(2) Reserve tank

(A) Full
(B) Low

Radiator	approx. 2.7 L (0.713 US gal.)
Reserve tank	approx. 0.56 L (0.148 US gal.)

IMPORTANT :

- Do not operate the engine without coolant.
- To fill the radiator system and the reserve tank, use fresh water and anti-freeze fluid.
- When the anti-freeze is mixed with water, the anti-freeze mixing ratio must be less than 50%
- Tighten the radiator cap properly. If the cap is loosely or not properly fitted, overheating of the engine can result due to coolant fluid loss.

■ Replacing Fuel Hose

Replace the hoses and clamps.
(See "Checking Fuel and Intake Air Line" every 200 hours maintenance.)

■ Replacing Intake Air line

Replace the hoses and clamps, if necessary.
(See "Checking Fuel and Intake Air Line" every 200 hours maintenance.)

OTHER ADJUSTMENTS AND REPLACEMENTS

PURGING FUEL SYSTEM

1. Fill up the excavator with fuel.
2. Turn the starter key to the position "RUN".
3. The air in the fuel system will automatically be purged within one minute.

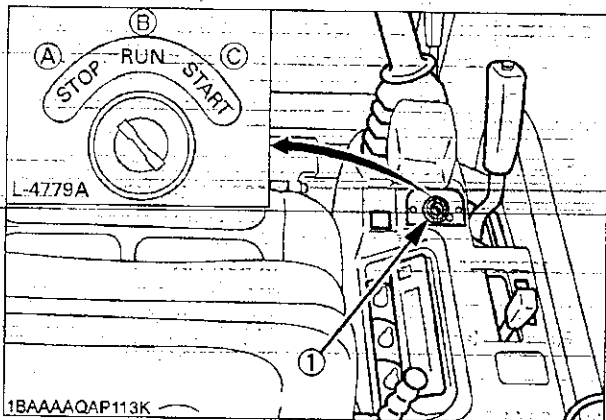

(1) Starter switch

- (A) "STOP"
- (B) "RUN"
- (C) "START"

IMPORTANT :

- If the purging was insufficient, the engine dies right after starting. In this case repeat steps (2) to (3) again.

ADJUSTMENT OF TRACKS

■ Rubber Tracks

Tension the tracks as specified:

1. Apply grease (2) to the grease nipple (1).

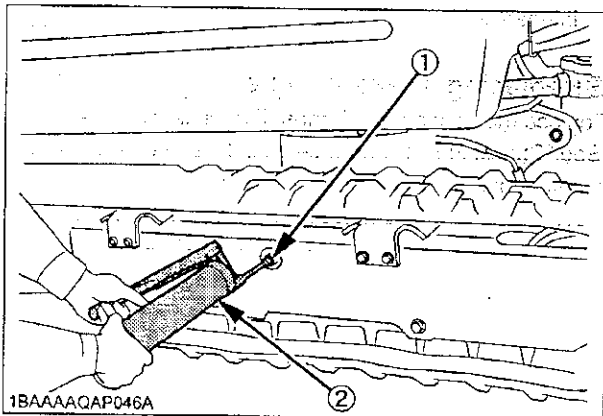

- (1) Grease nipple
- (2) Grease gun (Option)

2. Tension the track in the lifted position, so that the distance "A" (clearance between the center track roller and the track surface of the track) is 10 to 15 mm (0.4 to 0.6 in.) (see illustration) In this case, the track seam is positioned on the top center between the idler and the sprocket.



DANGER

To avoid serious injury or death:

- Do not work under the machine in this condition.
- For your safety do not rely on hydraulically supported devices, they may leak down and suddenly drop or be accidentally lowered.

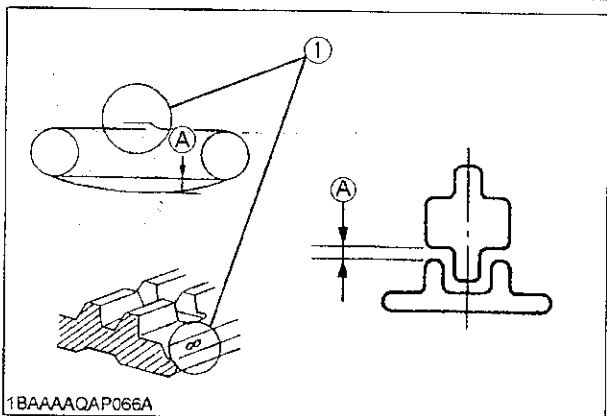
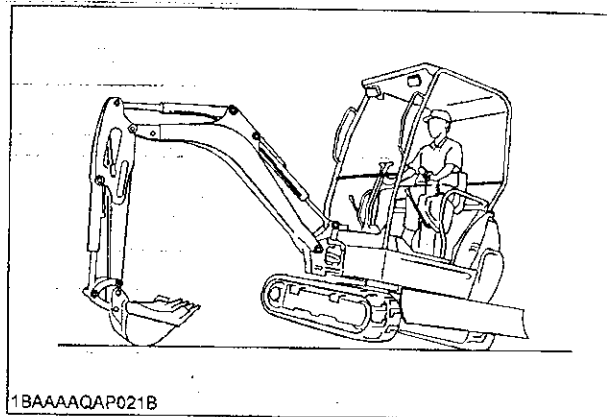

(1) Seam (Mark "∞")

(A)	10 to 15mm (0.4 to 0.6 in.)
-----	-----------------------------

IMPORTANT :

- **Track seam**
The ends of the rubber track are joined with a seam. When adjusting the tracks, the seam must be positioned on the top midway between the idler and the sprocket. By machines equipped with an upper roller, the seam mark should be positioned over the upper roller.
If the seam is positioned incorrectly, the tracks will be tensed to loosely, and a further readjustment will be necessary.
- Rotate the track after adjustment one to two times to check the tension. To loosen the rubber tracks, follow the same method as for steel tracks.
- Additionally following points are to be observed when adjusting rubber tracks.
 - (1) If the track slackens more than 25 mm (1.0 in.), readjust them.
 - (2) Check track tension 30 hours after initial use and readjust if necessary. Check and adjust thereafter every 50 service hours.

Special Information when Using Rubber Tracks

1. When turning, make a slow swing turn. Avoid spin turns to lessen lug wear and entry of dirt.
2. The relief valve may be activated if too much dirt and sand clog the tracks. In this case move the machine for a short distance straight backwards to let the earth and sand fall off, then a turn can be made.
3. Avoid using rubber track on riverbeds, stony underground, ferro-concrete and on iron plates. The rubber can damage as well as increase wear on the tracks.

- ◆ To loosen the tracks, follow following procedure:

**CAUTION**

To avoid personal injury:

- Do not loosen the grease nipple completely or too quickly. Otherwise grease under high pressure in the tension cylinder could squirt out.
 - Make sure that no obstacles, such as stones are caught in the track. Remove such obstacles before adjusting the track tension.
1. Loosen the bolt of the cover and remove the cover.
 2. Using a socket wrench, loosen the grease nipple a few turns.
 3. When grease oozes out from the thread, rotate the track and loosen the track in the lifted position (see illustration).

After adjustment is completed:

Using the socket wrench, tighten the grease nipple.

Tightening torque must be between 1000 to 1100 kgf-cm (72.3 to 79.6 ft-lbs.)

IMPORTANT :

- If the tracks are too tight, wear is increased.
- If the tracks are too loose, the track pads may collide with the sprocket, wear is increased.
The track may dislocate or come off.
- Clean the track after every use.
- Should the track tension be high due to sticking mud, lift the track with the help of the boom, arm and bucket, idle the engine and remove mud from the track, especially from the openings of the link plate carefully.

FUSES



CAUTION

To avoid personal injury:

- When changing fuse, stop the engine and turn the key in position "STOP".

■ Replacing Fuses

1. Remove the cover of the fuse box.
2. Replace the burnt out fuse with a fuse having the same capacity.

■ Fuse Capacities and Circuits

5A Glow 10A Main (with AI)		10A High speed
5A ROOM LIGHT	Spare	15A AUXILIARY
20A WORK LAMP		10A WIPER/WASHER
5A METER SUB		15A P. SOURCE/ BEACON
	5A	
	10A	
10A ALTERNATOR		5A HI SPEED
5A LEVER LOCK		5A WORK LAMP
10A HORN		10A METER MAIN

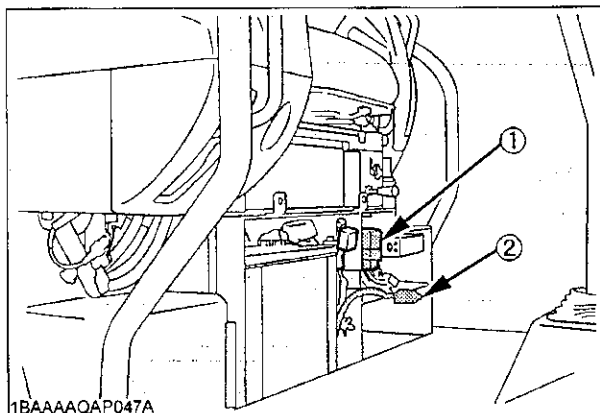

1BAAAAQAP047A

- (1) Fuse box
(2) Auxiliary electric

■ Slow Blow Fuse

Slow blow fuse is provided to protect the electrical circuits. If the fusible link is blown, check the electrical circuits for trouble and then replace with a new compatible slow blow fuse.

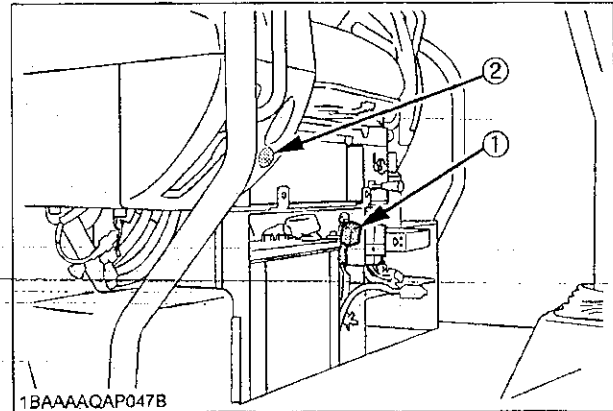

1BAAAAQAP047B

- (1) Slow blow fuse (50 A)
(2) Auxiliary electric

NOTE:

- If the machine keeps idling on the reserve power, the battery gets discharged. Raise the engine rpm.

■ Auxiliary Electric

Max power is less than 120 W including the "Beacon" (Auxiliary electric).

TROUBLESHOOTING

If the mini-excavator does not show the desired performance, or when trouble arises, refer to the table below and undertake appropriate measures.

Trouble		Cause	Countermeasure
		Lock levers in "UNLOCK" position	* Bring lock lever into "LOCK" position
		Fuel is too viscous	* Check fuel tank and filter * Remove impurities and water * If necessary, replace filter
		Air or water in the fuel system	* Remove water from the fuel tank * Check fuel pipe joint bolts and nuts for looseness * Purging of the fuel system (for fuel filter and injection pump see "PURGING OF THE FUEL SYSTEM" in the chapter "OTHER ADJUSTMENTS AND REPLACEMENTS".)
Engine	Starting difficulties	Oil viscosity is too high the engine runs sluggishly in winter	* Pour hot water over the radiator * Use oils of different viscosities depending on the ambient temperature. (Use SAE10W, SAE10W-30 or SAE10W-40)
		Battery is almost dead; insufficient compression	* Recharge battery
	Insufficient engine power	Low fuel level	* Check fuel and add if necessary
		Clogged air cleaner	* Clean the air filter element
	Engine suddenly stops	Low fuel level	* Check fuel and add if necessary * Purge the fuel system
	Abnormal exhaust gas colour	Poor fuel	* Use high quality fuel
		Too much engine oil	* Drain engine oil to prescribed oil level
	Water temperature in red zone (Overheating)	Defective seal of the water pump	* Replace
		Worn or torn fan belt	* Adjust or replace
		Thermostat is defect	* Replace
		Coolant level too low	* Fill to prescribed level
		Radiator grill or fins are clogged	* Clean
		Coolant is contaminated with rust from the cylinder head or crank case	* Replace coolant fluid and add anti-rust
		Defective radiator cap (Evaporation)	* Replace
Corroded coolant pipes		* Clean	
Continuous operation under full load		* Reduce load	
Cylinder head gasket is damaged (Coolant loss)		* Replace	
Engine oil level too low		* Fill to prescribed level	
Maladjustment of fuel injection		* Readjust ignition timing	
Use of poor fuel	* Use prescribed fuel		

Hydraulic System	Boom, arm, bucket, drive, swing and dozer power is too low	Hydraulic oil level too low	* Add oil
		Leakages of hoses and / or joints	* Replace hose or joint
	Swing motor and front attachment does not work	Lock lever in "LOCK" position	* Bring lock lever into "UNLOCK" position
Drive System	Deviation of drive direction	Blocked through stones	* Remove
		Track too loose or too tight	* Adjust accordingly
	Drive lever does not move	Lock lever in "LOCK" position	* Bring lock lever into "UNLOCK" position
AI	System indicator light flashes Models with AI	Fuse in fuse box defective	* Replace the fuse