



---

# Illustrated Parts Manual

**Operation and Safety  
Service and Maintenance  
Illustrated Parts Manual**

*Models*

**6308AN, 6308AN-6,  
8308AN & 9308AN**

1730616

September 09, 2020



Quality  
Endorsed  
Company

ISO 9001Lic 6080



## INTRODUCTION

This manual provides the information necessary for the safe use and operation of the JLG Model 6308AN, 6308AN-6, 8308AN and 9308AN Lighting Tower.

Specific operating details are contained in this publication to familiarise the operating personnel with the correct and safe procedures necessary to operate this equipment.

A separate Illustrated Parts and Service Manual is also available to easily identify the component parts required for service and maintenance purposes.

Take time to read this book thoroughly. If you are uncertain about any of the information presented, contact your JLG Service Office before operations commence.

All instructions in this manual are based on the machine being used under the operating conditions for which it was designed. In reading this manual, particular attention should be given to safety related Cautions and Warnings. Proper use and care will see this machine providing years of reliable service.

# CONTENTS

<b>Section One</b>	.....	<b>Operator and Safety</b>
<b>Section Two</b>	.....	<b>Service and Maintenance</b>
<b>Section Three</b>	.....	<b>Illustrated Parts</b>
<b>Section Four</b>	.....	<b>Recommended Spares Quick Reference</b>

## Customer Support

**JLG Industries (Port Macquarie)**  
11 Bolwarra Road  
PORT MACQUARIE NSW 2444  
Phone: (02) 6581 1111

**JLG Industries (Victoria)**  
30-32 Cyber Loop  
Dandenong VIC 3175  
Phone: (03) 9554 4333

**JLG Industries (Queensland)**  
223 Fison Avenue West  
Eagle Farm QLD 4009  
Phone: (07) 3309 9111

**JLG Industries (Western Australia)**  
39 Kewdale Road  
Kewdale, PERTH WA 6105  
Phone: (08) 9356 9811

**JLG Industries (NSW)**  
358 Park Road  
REGENTS PARK NSW 2143  
Phone: (02) 8718 6300

**JLG Industries (SA)**  
9 Nucera Court  
GREEN FIELDS SA 5107  
Phone: (08) 8259 8777

**JLG Industries (New Zealand)**  
2b Fisher Cresent  
Mt Wellington, Auckland  
New Zealand  
Phone: + 64 9276 1728

# SECTION ONE

## OPERATORS AND SAFETY MANUAL

<b>CONTENTS</b>	<b>Page</b>
• General	1-1
• Safety Precautions	1-2
• Preparation for Use	1-5
• Delivery and Periodic Inspection	1-5
• Controls Identification	1-6
• Machine Set up/Pack up Instructions.	1-8
• Forklifting Machine	1-11
• Craning Machine	1-11
• Towing Instructions	1-12

## GENERAL

This section prescribes the proper and safe practices for machine operation. In order to promote proper usage of the machine, it is mandatory that a daily routine be established based on the regular maintenance schedule in the service and maintenance section of this manual. A maintenance program shall also be established by a qualified person and should be followed to ensure that the machine is safe to operate.

The user/operator of the machine shall not accept operating responsibility until this manual has been read and operation of the machine under the supervision of an experienced and qualified operator has been completed. If there is a question on application and/or operation, JLG Industries Customer Support Department should be consulted on (02) 6581 1111 (Australia).



**MODIFICATION OF THE MACHINE WITHOUT THE PRIOR WRITTEN APPROVAL OF JLG INDUSTRIES (AUSTRALIA) IS PROHIBITED.**

## SAFETY ALERT SYMBOLS AND SAFETY SIGNAL WORDS



This is the Safety Alert Symbol. It is used to alert you to the potential personal injury hazards. Obey all safety messages that follow this symbol to avoid possible injury or death.

### **DANGER**

INDICATES AN IMMINENTLY HAZARDOUS SITUATION. IF NOT AVOIDED, WILL RESULT IN SERIOUS INJURY OR DEATH. THIS DECAL WILL HAVE A RED BACKGROUND.

### **WARNING**

INDICATES A POTENTIALLY HAZARDOUS SITUATION. IF NOT AVOIDED, COULD RESULT IN SERIOUS INJURY OR DEATH. THIS DECAL WILL HAVE AN ORANGE BACKGROUND.

### **CAUTION**

INDICATES A POTENTIALLY HAZARDOUS SITUATION. IF NOT AVOIDED, MAY RESULT IN MINOR OR MODERATE INJURY. IT MAY ALSO ALERT AGAINST UNSAFE PRACTICES. THIS DECAL WILL HAVE A YELLOW BACKGROUND.

### **IMPORTANT**

INDICATES PROCEDURES ESSENTIAL FOR SAFE OPERATION. THIS DECAL WILL HAVE A GREEN BACKGROUND.

**SAFETY PRECAUTIONS**

**SAFETY PRECAUTIONS**

This section outlines the safety precautions applicable to the general use of this product.

Throughout the Operator and Safety section of this manual, cautions and warnings are shown in **BOLD TYPE**. These outline where special care is required when undertaking the various procedures outlined.

**NOTE:** The safety precautions applicable to the service and maintenance of the machine are covered in the SAFETY PRECAUTIONS section of the Service and Maintenance Manual.

The user of this machine should read this manual thoroughly to ensure that all operating procedures are clearly understood prior to accepting responsibility.

- Modifications or alterations to the lighting tower are not permitted without the prior written permission of the manufacturer.
- Failure to comply with the safety precautions listed here and elsewhere in the manual may result in injury or death.
- When handling the lighting tower other than towing for the purposes of lifting or manoeuvring, there are forklift pockets provided at the rear of the machine and 4 lifting points provided on the main frame for lifting by a crane. Ensure that the forklift or crane is of suitable capacity prior to attempting the lift. Refer to the diagrams shown elsewhere in this manual for correct handling procedures using a crane and forklift.

- Prior to erecting the mast the operator should ensure that no overhead obstructions are within a 6-metre radius of the base of the machine.



**THERE IS ELECTROCUTION HAZARD TO THE OPERATORS IF THE MACHINE IS OPERATED NEAR OVERHEAD POWERLINES**

The following chart is a guide to the applicable safe operating distances from overhead power lines.

Contact local authorities for the relevant minimum safe approach distances (MSAD's) in your area. Local statutory requirements may take precedence over MSAD's listed here.

Voltage Range (Phase to Phase)	MINIMUM SAFE DISTANCE In Metres (feet)
0-300V	AVOID CONTACT
Over 300 to 50 KV	3 (10)
Over 50KV to 200 KV	5 (15)
Over 200 KV to 350 KV	6 (20)
Over 350 KV to 500 KV	8 (25)
Over 500 KV to 750KV	11 (35)
Over 750 KV to 1000 KV	14 (45)

Be aware of the radius of the mast when telescoped out and lowered. Be aware of swaying power lines and swaying tree branches in strong winds.

- Be familiar with all controls on the machine prior to operation. The machine incorporates powerful hydraulic mechanisms that can cause serious mechanical damage if the machine is allowed to strike external structures such as buildings etc.

**SAFETY PRECAUTIONS**

- Ensure that the ground is suitable to support the machine, particularly under each of the outrigger pads. A suitable packing material such as a timber block may be required on soft surfaces to ensure that the outriggers do not sink under the weight.

**⚠ WARNING**

**FAILURE OF THE OUTRIGGERS TO SUPPORT THE MACHINE DUE TO SOFT SURFACES COULD CAUSE THE MACHINE TO TIP OVER IN WINDY CONDITIONS.**

- Do not erect the machine in winds greater than 118kmh. Tipping of the machine is possible.

**⚠ WARNING**

**NEVER RAISE THE MAST FULLY WITHOUT FIRST SETTING ALL OUTRIGGERS AND ENSURING THE LIGHTING TOWER IS LEVEL. A BUBBLE LEVEL IS MOUNTED AT THE FRONT OF THE MACHINE NEAR THE BASE OF THE MAST TO AID IN LEVELLING OF THE MACHINE.**

- The model 6308AN Lighting Tower incorporates an A.C. alternator which generates lethal voltages. Do NOT operate the machine without all safety covers in place covering all wiring and electrical devices.

**⚠ DANGER**

**DO NOT TOUCH LAMP TERMINALS OR SOCKETS. DANGEROUS VOLTAGES MAY BE PRESENT EVEN WHEN POWER IS OFF.**

Shutdown engine, switch off all circuit breakers, and allow 10-minutes for ballast capacitors to discharge before replacing lamps. Check capacitors are below 10VDC before service to lamp sockets or ballast circuits by trained service personnel only.

- Do not alter the electrical wiring type, size or standard in any way without prior written approval from the manufacturer.
- The lighting tower is NOT a mobile generator set. It should only be used for the specific purpose for which it was designed.
- The hydraulically operated mast has hazardous crushing/pinch points. Do NOT put arms, hands etc. near the mast structure while it is in operation.
- The metal halide lamp fixtures can get extremely hot during operation. Do not operate the lights in easy reach of people's hands. Even after lights have extinguished, the lamp fixtures can remain hot for up to 20 minutes.
- The mast of the Lighting Tower is designed specifically to carry the 4 lights supplied. Alternative lights should not be adopted unless specifically authorised by the manufacturer.
- The mast is not a crane. Do not attempt to lift any objects by using the mast and hydraulic system.
- There are moving parts in and around the engine and alternator area of the unit. Prior to carrying out any maintenance, checks or accessing the engine area ensure engine is shut down and the mast retracted.

## PREPARATION FOR USE

### PREPARATION FOR USE

Before a new machine is put into operation it must be carefully inspected for any evidence of damage resulting from shipment.

**Note:** Regular periodic inspections are a required aspect of the ongoing maintenance of the machine.

Preparation for use of the machine requires good common sense principles ensuring that a complete function check together with visual inspections show that everything is working correctly.

Function checks are to include the following items.

1. Outriggers slide in and out freely.
2. Outrigger Jacks operate freely.
3. Operation of the 3 mast hydraulic levers in both directions to ensure free correct movement of the mast.

Prior to use all fluid levels should be checked including

- Radiator coolant.
- Engine oil level.
- Fuel level.

Ensure that all warning decals have been read and understood prior to operating machine.

Ensure that machine set up location is clear of any dangers such as roadways with moving traffic, moving machinery etc.

Some locations may require that checks are made with the regulatory authority such as councils prior to the set up and use of this lighting tower.

Ensure that machine is securely parked prior to use. Barriers, fences and warning signs may need to be

erected to ensure awareness of the unit in operation.

### DELIVERY AND PERIODIC INSPECTION

## **IMPORTANT**

This machine requires periodic safety and maintenance inspections by a qualified person.

Particular attention is required during checks to ensure that the machine functions as it was designed to. There should be no abnormal noises or vibrations evident during the machine's operation. In the event that an operator becomes aware of any abnormal operation while using the machine, then it should be shutdown immediately, stowed safely and the problem reported to an authorised person.

Reference should be made to Section 2 (Service and Maintenance) for procedures in regular and periodic inspections of this machine. All machines require both preventive and corrective maintenance throughout their useful service life to maintain the machine in a safe and reliable condition.

**CONTROLS IDENTIFICATION**

**CONTROLS IDENTIFICATION**

**Engine Control Panel**

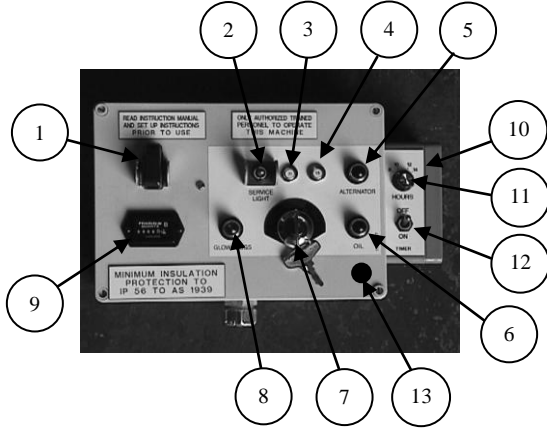

1. Ignition on – emergency shutdown switch.
2. Service light switch for optional cabin light.
3. Circuit breaker 15 Amp protects D.C. control circuits.
4. Circuit breaker 20 Amp master D.C. circuit protection.
5. Alternator warning light. This light will illuminate if loss of alternator charge is experienced.
6. On some units without an engine shutdown system, this is a low engine oil pressure warning light. On units retrofitted with an Engine Shutdown System this is an Engine distress light indicating, low oil pressure, low water level, high engine temperature condition.
7. Keyswitch. Turn left for engine glow preheat. Hold for 2 to 3 seconds then turn the key to the right to start the engine.
8. Glow plug light as described in item 7.
9. Hourmeter. Shows number of hours that the machine has been on.
10. Engine shutdown timer module.
11. Timer duration selector switch.
12. Timer on/off switch.
13. Start Override Switch (Prior to S/N 6308AN081).

**Engine Shutdown Unit**

Located within the above control box is an engine monitoring shutdown system. In the event that one of the following conditions should take place, the engine will shutdown and illuminate the Engine Distress Light.

1. Low oil pressure
2. Low water level
3. High engine temperature

Should a shutdown occur, the system can be reset by turning off the ignition. The fault should be corrected prior to restarting.

**Light Control Panel**

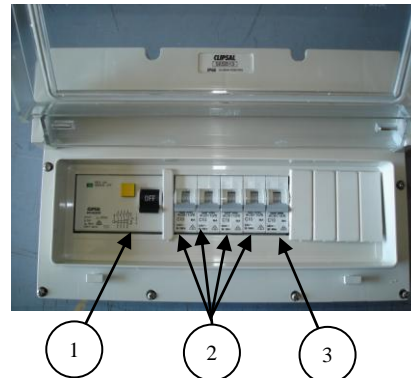

1. A.C. Residual Current Device (R.C.D.) provides protection to all A.C. circuits connected to the Alternator.
2. Switch/circuit breaker for lights one to four (one to six for 6308AN-6 & 9308AN). Protects against overload on these lights.
3. Circuit breaker for General Purpose Outlet (G.P.O) or R.C.D. test point. Also provides overload protection.

**Hydraulic Controls for Mast**

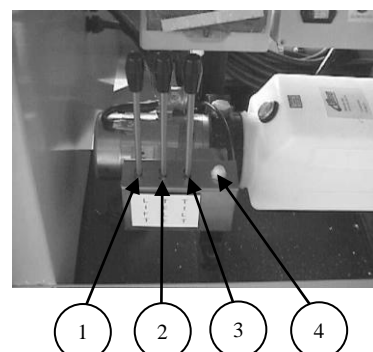

**CONTROLS IDENTIFICATION**

1. Mast raise and lower control lever. Pushing forward or pulling back will raise and lower the mast respectively. Speed of the raise and lower function can be controlled by pushing or pulling the lever further away from the centre off position.
2. Telescope in/out control lever. Operating this lever will telescope the upper boom extend in and out.
3. Tilt mechanism control lever. Operating this lever will allow the light bar head to be tilted up and down for aiming lights. It is also used when stowing the mast to ensure the lighting bar head is tucked in for transport.
4. Hydraulic controls Enable Switch which must be pressed during the operation of any of the hydraulic control levers.

3. Mast Rotate Lockpin. This pin is spring loaded into the locked position. It must be pulled out prior to rotating mast. The pin locks the mast every 15°. The mast may be locked in any position by using the rotate lock, however, in exceptionally high winds the mast may move slightly if it is positioned between the 15° lockpin indents. It will move to the nearest lockpin position and the lockpin will engage to prevent further movement.

**Mast Rotate Mechanism**

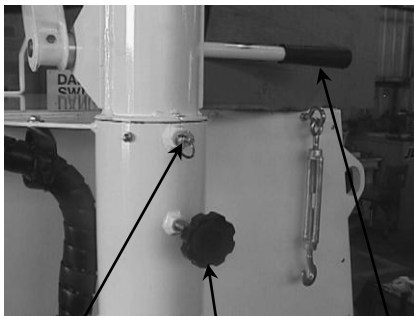

3. Rotate Lockpin    1. Rotate Lock    2. Rotate Handle

1. Mast Rotate Locking Mechanism. Rotate this knob counter-clockwise to release mast lock prior to rotating.
2. Mast Rotate Handle. Use this control to manually rotate mast through 350 degrees to desired position. Ensure mast lock is rotated clockwise to lock mast prior to use.

**Park Brake**

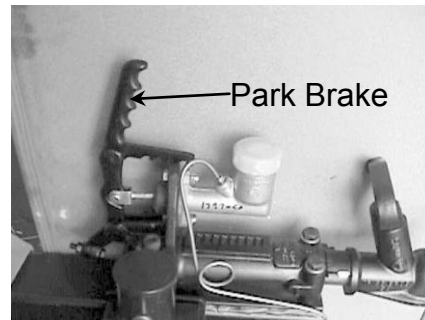

The Park brake handle shown above acts on the hydraulic master cylinder. It is locked into position by the ratchet locking bar. To apply the park brake, pull the handle forward and lock the ratchet bar into place as shown.

**⚠ WARNING**

**PRIOR TO TOWING THE VEHICLE, ENSURE THE PARK BRAKE IS RELEASED AND THAT THE RATCHET BAR IS SWUNG WELL OUT OF THE WAY. FAILURE TO DO THIS COULD CAUSE THE BRAKES TO LOCK ON DURING TOWING.**

**MACHINE SET UP AND PACK UP**

**MACHINE SET UP AND PACK UP INSTRUCTIONS**

**IMPORTANT**

The following setup instructions are applicable when the Light Tower is towed into position. When the machine is transported by truck and then forklifted into position, ensure that the retractable drawbar is extended and pinned prior to setup and raising the mast. Failure to do so may affect the stability of the machine under some operating conditions. The front outrigger leg may then be lowered to support the front of the machine and the transport leg raised and pinned in the upper position. A jockey wheel is provided to assist in manually manoeuvring the machine. Do not use the transport leg or jockey wheel to support the machine when raising the mast.

**Machine Setup Instructions**

1. Select a flat level area to park the machine.
2. Ensure parking brake is applied prior to unhitching unit, removing safety chain and electrical cable.
3. Lower the front outrigger jack to take the weight of the unit. Raise unit until it unhitches from the towing vehicle. Drive the towing vehicle forward clear of the draw bar.
4. Lower the front outrigger jack down until the draw bar is sloping forward slightly. Ensure that Jockey wheel is raised.
5. At the rear of the unit, locate and slide out the left outrigger arm and lock pin into position. Rotate the jack from the stowed position through 180° until the foot is just above the ground. Turn the jack handle to lower the foot against the ground.

6. Repeat step 5 for the right hand outrigger arm and jack.
7. Raise the front of the machine by adjusting the front outrigger jack until the machine is level and each outrigger support jack is pressing firmly against the ground. There is a fourth outrigger leg located at the rear of the machine for 6308AN-6 and 9308AN. Release the remote locking pin and withdraw the outrigger leg outwards to the locked position approx. 0.6 metre. Rotate the outrigger leg through 90 degrees and adjust by turning the handle clockwise until the leg is in firm contact with the ground. (Approx. 2 turns after contact). Do not attempt to jack up the machine by overextending.



**IMPORTANT**

It is not necessary to raise the wheels of the machine off the ground when lowering the outrigger jacks. When set up correctly the wheels may still be in firm contact with the ground. If the surface is uneven though, one wheel may need to be raised off the ground to level the machine. A bubble level is provided on the front of the machine to assist in levelling.

**MACHINE SET UP AND PACK UP**

**⚠ CAUTION**

DO NOT USE THE JOCKEY WHEEL TO SUPPORT THE MACHINE WHEN THE MAST IS RAISED.

- Unlatch the transport turnbuckles. Ensure that the light bar assembly is clear to swing out and away from its stowed position.

**⚠ CAUTION**

PRIOR TO RAISING THE MAST, CHECK AND ENSURE THAT NO OBSTRUCTIONS ARE LOCATED ABOVE THE UNIT TO A HEIGHT OF 10 METRES. REFER ALSO TO SAFE DISTANCES FROM POWER LINES AS DESCRIBED IN SECTION 1 (SAFETY PRECAUTIONS).

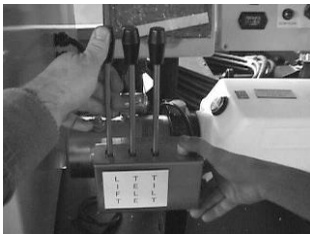

- Slowly operate the light bar tilt hydraulic lever and hydraulic controls enable switch to move the light bar forward, up and away from the front of the tow hitch.
- Operate the lift control lever and hydraulic controls enable switch to continue to raise the mast to full elevation.
- Operate the telescope lever and hydraulic controls enable switch to extend the mast to desired height.
- Finally, adjust the light bar tilt to the desired angle by operating the tilt control lever and hydraulic controls enable switch.

**⚠ CAUTION**

TO AVOID CRUSHING INJURY, KEEP HANDS AND ARMS AWAY FROM THE MOVING PARTS OF THE MAST.

**Turning Lights On**



- Start the engine by switching on the ignition switch, turning the key counter-clockwise to the Glow Preheat position and hold for 2 to 3 seconds, then turning to the right to start the Engine. Once started, allow the engine to warm for a minute prior to using.

**NOTE:** For machines prior to S/N 6308AN081, the Engine Distress Shutdown system if installed requires a build up of engine oil pressure before the engine will start. To overcome a delay in starting, a momentary pushbutton called “Start Override” is located on the control panel below the Engine Distress Light. Hold this button in when cranking engine to start.



- Switch on main circuit breaker. Then switch on the light circuit breakers 1, 2, 3 & 4 (1, 2, 3, 4, 5 & 6 for 6308AN-6 and 9308AN) to activate lights.

## MACHINE SET UP AND PACK UP

15. Allow lights to warm up and reach full brightness (about 3 minutes).

**NOTE:** The lamps used are a Metal Halide Gas Discharge type. If they are switched off and back on again after they have been running they may take up to 15 minutes to re-ignite. This is normal for this type of lamp.

### Machine Pack Up

Packing up the machine for towing or transport is a reversal of the setup steps. Take special care when lowering the boom and ensure it rests neatly in the boom cradle at the rear of the machine.



Ensure the light bar is stowed in towards the mast and is locked against the stop prior to towing.

### **IMPORTANT**

The light bar tilt mechanism is hydraulically locked into place during transport. However, for added safety 2 turn buckles attached to the front of the machine provide rigid support for extended transport. The turnbuckles need only be tightened "lightly" to provide adequate support.

When retracting the rear outrigger legs, ensure that they are pinned and locked in the retracted position. Rotate the outrigger jack 180 degrees and turn the handle so that the jack pulls down lightly on the rubber anti shake pads as shown below.

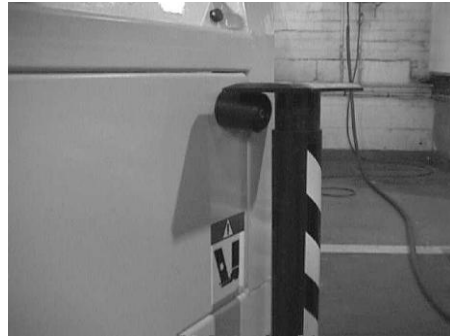

Once the mast is lowered the front drawbar mounted jockey wheel may be lowered and locked into position. The machine can then be manually positioned for stowage or prepared for towing. Once the machine is attached to the towing vehicle, ensure that the jockey wheel is raised and locked in the stowed position.

### **IMPORTANT**

When loading the machine onto a tilt-tray truck, do not winch the machine while it is supported by the jockey wheel. Lateral forces can cause the jockey wheel to collapse resulting in machine damage.

**LIFTING MACHINE**

**FORKLIFTING MACHINE**



**Forklifting Procedure**

**⚠ CAUTION**

WHEN USING A FORKLIFT TO MOVE THE MACHINE ONLY THE FORKLIFT POCKETS LOCATED AT THE REAR OF THE MACHINE SHOULD BE USED.

Prior to using a forklift to lift the machine, ensure that the mast is lowered to the stowed position, the lights are stowed and the engine generator is shut down.

The machine weighs approximately 1700kg. Ensure that only a suitable forklift with adequate capacity is used to lift the machine.

When positioning the forklift tines into the forklift pockets, ensure the tines go through far enough to pick up the tine support bar located across the main frame of the unit. Tine penetration should be at least 800mm from the rear wall of the light tower.

**CRANING MACHINE**



**Craning Procedure**

**⚠ WARNING**

USE ONLY THE 4 LIFTING POINTS PROVIDED TO LIFT THE LIGHTING TOWER WITH A CRANE. DO NOT LIFT THE ASSEMBLY BY THE MAST. DOING SO WILL RESULT IN SEVERE DAMAGE TO THE UNIT AND POSSIBLE INJURY TO THE PERSONNEL UNDERTAKING THIS TASK.

The mast and lights should be in the stowed position and the engine generator shut down prior to lifting the machine off the ground. Ensure all outrigger legs and the drawbar are in the retracted and locked position.

Using suitable lifting equipment attached to the lifting lug at each corner of the machine, proceed to lift the machine as per the instructions provided for the lifting crane.

**TOWING INSTRUCTIONS**

**⚠ CAUTION**

PRIOR TO TOWING THE LIGHT TOWER UNIT THIS MANUAL SHOULD BE READ AND UNDERSTOOD.

THE LIGHT TOWER HAS A GROSS VEHICLE MAXIMUM WEIGHT OF UP TO 1700 KGS. ENSURE THAT THE TOWING VEHICLE AND TOW BAR ARE RATED TO TOW A VEHICLE OF THIS WEIGHT SAFELY.

THE STANDARD TOW COUPLING IS 2 INCH 51MM BALL TYPE. OTHERS ARE AVAILABLE AS AN OPTION ON REQUEST. THE LIGHT TOWER USES A HYDRAULIC OVERRIDING BRAKE MECHANISM. YOU SHOULD MAKE SURE YOU UNDERSTAND THE OPERATION OF THIS MECHANISM PRIOR TO USE.

**⚠ WARNING**

FAILURE TO PROPERLY ENGAGE THE OVERRIDING BRAKE MECHANISM COULD CAUSE THE VEHICLE TO GET OUT OF CONTROL AND CAUSE DEATH OR SERIOUS INJURY.

**Prior to Towing**

- Ensure that machine is shut down, the mast correctly stowed and access doors closed.
- Retract and stow the rear outriggers.
- Ensure the extendable tow bar is extended and locked.
- Attach the Light Tower to the towing vehicle and ensure ball coupling is locked in.
- Attach the safety chain.
- Connect and test the lights including turn indicators and brake lights.
- Disconnect the hand brake by unlocking and swinging the toothed ratchet up and towards the rear.

- Swing the front outrigger leg up into the horizontal stowed position.
- Ensure that the overriding brake lockout mechanism is swung up to allow brakes to work.

**NOTE:** For reversing the unit the overriding brake lockout mechanism may need to be swung down to prevent brakes being applied when reversing.

- Move off slowly and apply the brake gently to test the coupling and brake action.

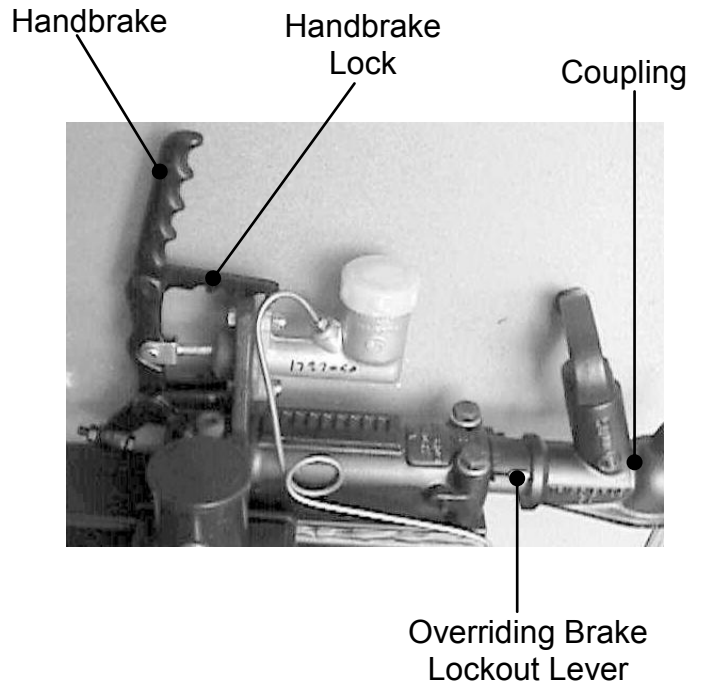

# SECTION TWO

## SERVICE AND MAINTENANCE

### CONTENTS:

	<b>Page</b>
• SAFETY PRECAUTIONS	2-2
• SPECIFICATIONS	2-4
• PRODUCT DESCRIPTION	2-6
• MAINTENANCE PROCEDURES	2-9
➤ Changing engine oil	2-10
➤ Floodlight lamp change	2-10
➤ Removing floodlight assembly	2-12
➤ Removing mast assembly	2-13
➤ Replacement of AC circuit breakers	2-13
➤ Remove/replace lamp ballasts.	2-14
➤ Setting hydraulic pressure	2-15
• FAULT DIAGNOSIS CHART	2-16
➤ Lights generator circuit	2-16
➤ Engine	2-17
➤ Electrical Safety Tests	2-18
• MAINTENANCE SCHEDULE	2-20
• HYDRAULIC SCHEMATIC DIAGRAM	2-21
• ELECTRICAL SCHEMATIC DIAGRAM	
➤ AC System	2-22
➤ DC System	2-23

## SAFETY ALERT SYMBOLS AND SAFETY SIGNAL WORDS



This is the Safety Alert Symbol. It is used to alert you to the potential personal injury hazards. Obey all safety messages that follow this symbol to avoid possible injury or death.

### **! DANGER**

INDICATES AN IMMINENTLY HAZARDOUS SITUATION. IF NOT AVOIDED, WILL RESULT IN SERIOUS INJURY OR DEATH. THIS DECAL WILL HAVE A RED BACKGROUND.

### **! WARNING**

INDICATES A POTENTIALLY HAZARDOUS SITUATION. IF NOT AVOIDED, COULD RESULT IN SERIOUS INJURY OR DEATH. THIS DECAL WILL HAVE AN ORANGE BACKGROUND.

### **! CAUTION**

INDICATES A POTENTIALLY HAZARDOUS SITUATION. IF NOT AVOIDED, MAY RESULT IN MINOR OR MODERATE INJURY. IT MAY ALSO ALERT AGAINST UNSAFE PRACTICES. THIS DECAL WILL HAVE A YELLOW BACKGROUND.

### **IMPORTANT**

INDICATES PROCEDURES ESSENTIAL FOR SAFE OPERATION. THIS DECAL WILL HAVE A GREEN BACKGROUND.

**SAFETY PRECAUTIONS**

Throughout the service and maintenance section of this manual cautions and warnings are shown in **BOLD TYPE**. These outline where special care is required when undertaking the various procedures outlined.

**⚠ CAUTION**

**WHEN AN ABNORMAL CONDITION IS NOTED WITH THE MACHINE AND THE PROCEDURES WITHIN THIS MANUAL DO NOT COVER THE CONDITION, WORK SHOULD BE STOPPED UNTIL TECHNICALLY QUALIFIED GUIDANCE CAN BE CONSULTED.**

- Modifications or alterations to the lighting tower are not permitted without the prior written permission of the manufacturer.
- Failure to comply with the safety precautions listed here and elsewhere in the manual may result in severe injury or death.
- When handling the lighting tower other than towing for the purposes of lifting or manoeuvring, there are forklift pockets provided at the rear of the machine and 4 lifting points provided on the main frame for lifting by a crane. Ensure that the forklift or crane is of suitable capacity prior to attempting the lift. Refer to the diagrams shown elsewhere in this manual for correct handling procedures using a crane and forklift.

**HYDRAULIC SYSTEM**

The lighting tower incorporates a hydraulic system for the purpose of operating the mast functions. Dangerous hydraulic pressures are created by this system. All applicable

safety precautions should be taken when working on the hydraulic system.

**⚠ WARNING**

**SHUTDOWN THE MACHINE PRIOR TO DISCONNECTING HYDRAULIC LINES. ENSURE THE MACHINE IS SAFELY SUPPORTED PRIOR TO REMOVAL OF HYDRAULIC LINES, CYLINDERS ETC.**

**ELECTRICAL SYSTEM**

**⚠ WARNING**

**THE LIGHTING TOWER INCORPORATES AN ELECTRICAL SYSTEM WHICH GENERATES VOLTAGES IN EXCESS OF 500 VOLTS AC.**

**SEVERE INJURY OR DEATH MAY RESULT IF WORK IS UNDERTAKEN BY UNTRAINED AND UNQUALIFIED PERSONNEL.**

**ALL SAFETY PRECAUTIONS SHOULD BE UNDERTAKEN WHEN WORKING ON THE MACHINE.**

**SHUTDOWN THE MACHINE PRIOR TO DISCONNECTING ELECTRICAL WIRING.**

**⚠ DANGER**

**DANGEROUS VOLTAGES MAY BE PRESENT EVEN WHEN POWER IS OFF.**

**SAFETY PRECAUTIONS**

**SHUTDOWN ENGINE**

Shutdown engine, switch off all circuit breakers and allow 10-minutes for ballast capacitors to discharge before replacing lamps. Check capacitors are below 10VDC before service to lamp sockets or ballast circuits by trained service personnel only.

**SPECIFICATIONS**

**1.1 CAPACITIES**

**6308AN & 6308AN-6**

Hydraulic Oil Tank	5.6 L
Fuel Tank	167 L
Radiator	4.2 L
Engine Crank Case	7.0 L (D1403) 4.9 L (403D-11)

**8308AN**

Hydraulic Oil Tank	5.6 L
Fuel Tank	167 L
Radiator	5.5 L
Engine Crank Case	5.6 L

**9308AN**

Hydraulic Oil Tank	5.6 L
Fuel Tank	167 L
Radiator	8.1 L
Engine Crank Case	5.6 L

**1.2 COMPONENT DATA**

**Engine**

**6308AN & 6308AN-6**

Kubota D1403BG  
3 Cylinder, water-cooled  
Rated Power 14.3HP SAE Net  
@1500RPM (10.7 kW)

Perkins 403D-11  
3 Cylinder, water-cooled  
Rated Power 11.5HP SAE Net  
@1500RPM (8.6 kW)

**8308AN & 9308AN**

Kubota D1703BG  
3 Cylinder, water-cooled  
Rated Power 17.2HP SAE Net  
@1500RPM (12.8 kW)

Kubota V2203BG  
4 Cylinder, 2.2 litre, water-cooled  
Rated Power 23.3HP SAE Net  
@1500RPM (17.2 kW)

**Alternator**

**6308AN & 6308AN-6**

Sincro - Model HB45AR  
Rated Power 14 kVA (opt 16 kVA)  
Configuration 3 phase

**8308AN & 9308AN**

Sincro - Model HB4  
Rated Power. 16.5 k VA  
Configuration 3 phase

Sincro - Model SK160MB  
Rated Power. 20 kVA  
Configuration 3 phase

**Hydraulics – Fenner Fluid Power**

Motor 12 Volt D.C.  
Operating Pressure 2500 psi  
17.23 MPa  
Pump Volume 0.8 cm<sup>3</sup>/rev

**Lights – Sylvania Briteline 2000**

**6308AN & 9308AN**

HID Metal Halide  
rated power 1500 W

**6308AN-6**

HID Metal Halide  
rated power 1000 W

**6308AN-6 HPS**

High Pressure Sodium  
rated power 1000 W

**8308AN**

HID Metal Halide  
Rated power 2000 W

**Electrical Controls**

R.C.D. trip rating 30 mA  
Lamp Switches/  
Circuit breakers 10 A

**SPECIFICATIONS**

**Axle**

Single Axle (IRS) Independent Rubber Suspension.

**Brakes**

Hydraulic Overriding. Drum.

**Tyres and Wheels**

Tyre Dimensions: 205/80 x 16"  
Wheel Dimensions: 16" x 6J

Wheel Nuts            ½"UNF  
Tightening Torque    125 Nm

**Battery**

Model                    N70ZZ Marine  
Voltage                  12 V DC  
C.C.A.                    600 A  
Reserve Current        130 A

**1.3 DIMENSIONS**

Length (Drawbar Stowed) 2.5 m  
Width                    1.74 m  
Height Stowed            2.4 m  
Height Erected            8 m

**1.4 WEIGHT**

aggregate trailer mass 1650 kg  
Towball weight            80 kg

**1.5 PERFORMANCE**

Mast lift time            110 s  
Mast Lower time         90 s  
Rated Towing Speed     80 km/hr  
Fuel Consumption        2.6 L/hr  
(6308AN & 6308AN-6)  
Fuel Consumption        2.9 L/hr  
(8308AN & 9308AN)

**1.6 PRESSURE SETTINGS**

System Pressure 2400 psi (165.5 bar)

**PRODUCT DESCRIPTION**

**PRODUCT DESCRIPTION**

The model 6308AN Lighting Tower is an ultra compact unit designed for maximum performance incorporating all the features of an advanced design while maintaining a compact overall size.

Its unique mast design allows for maximum height while still maintaining a compact stowed profile. The Tower's short length allows for "across the tray" stowing on trucks which allows for a greater number of units to be carried on an 8 foot wide truck tray.

The unit is powered by a Kubota 3 cylinder water cooled diesel engine coupled to a three phase star configured self regulating alternator.

Four 1500 Watt Sylvania Briteline metal halide floodlight fixtures provide a wide light dispersion while maintaining a compact overall size for minimum sail area and maximum stability in high winds.

**Mast Operation**

The unique mast design allows for a working height of 8m. It is actuated by a single lift cylinder for the raise lower function. In addition, the upper section has a double acting cylinder for the telescope function. The four lamps are mounted on a light bar assembly which has a single double acting cylinder for tilting the complete assembly. This function aids in the directional control of the light array together with providing adjustment when the mast is lowered for compact storage.

Three lever type hydraulic valve controls are provided for the operation

of the three mast functions of lift up, telescope, tilt.

A manual mast rotation system is employed with locking mechanism to allow for easy light positioning through 350 degrees of operation.

**Frame**

The light tower unit is constructed on a fully welded robust steel chassis.

Two large gas strut assisted doors swing up to provide access to all internal components for service and maintenance.

An additional small door is provided on the left side of the machine to access both the electrical and hydraulic function controls.

An Independent Rubber Suspension (IRS) axle is fitted to the machine providing a smoother ride with minimal maintenance and optimum towing stability. Hydraulic override brakes are fitted for good stopping performance and a park brake is fitted for secure stowage of the machine.

Stability of the machine is provided by four outrigger legs stowed integrally on the machine.

Three pull out legs are provided at the rear, each with a wind down jack mechanism.

A single support leg is provided as an integral part of the retractable tow bar mechanism at the front of the machine. Together the four outrigger legs provide a wide footprint to maintain machine stability in winds up to 118km/h.

**PRODUCT DESCRIPTION**

**Transport**

In addition, a transport leg is provided on the draw bar near the base of the mast. This leg may be pinned in the lowered position to support the front of the machine for transport or storage in a yard without the need to extend the draw bar.



**ENSURE THE TRANSPORT LEG IS RAISED AND PINNED PRIOR TO TOWING THE LIGHTING TOWER.**



**DO NOT CHAIN THE MACHINE DOWN USING THE DRAWBAR IN THE EXTENDED POSITION AND THE FRONT JACK OR JOCKEY WHEEL DOWN. DAMAGE TO THE DRAWBAR, JACK OR JOCKEY WHEEL MAY RESULT FROM EXCESSIVE FORCES. USE THE TRANSPORT LEG.**

**Electrical**

Power for the four metal halide lights comes from a 13KVA three-phase alternator. The output of the alternator connects directly to a main Residual Current Device (RCD) located in the light's electrical control box. The RCD has a rated trip current of 30 milliamps providing protection to operators against hazards of electrocution.

Four separate circuit breakers each rated at 10 amps provide protection to each of the Four light circuits. They also act as the main light circuit isolation switches.

An optional single phase 10 amp General Purpose Outlet (GPO) is also provided. This circuit has a separate

10 Amp breaker for protection. On machines without a GPO, a separate RCD test point is fitted.

**Engine Control Panel**

A compact engine control panel provides a key operated ignition switch with a glow and start position. Warning lamps are also provided on this panel for alternator charge, low engine oil pressure, and glow plugs. Also included is a master ignition toggle switch with emergency quick shut off mechanism. An hour meter and two D.C. push to reset type circuit breakers rated at 20 amps for main D.C. circuit protection and 15 amps for control circuit protection.

Located within the engine control panel enclosure is a timer module which forms part of the glow plug circuit. It provides a preset preheat time for the glow plugs ensuring reliable performance.

**Hydraulic System**

A 12VDC Hydraulic power pack provides the power source to control the mast assembly.

Three lever actuated directional control valves combined with hydraulic controls enable switch, allow for proportional directional control of mast lift, telescope, and tilt functions.

A main pressure relief valve protects the hydraulic system and mast mechanics from over pressure. It is set for an operating pressure of 2500PSI.

The pump motor draws power from the engine start battery, which is a marine/deep cycle style, therefore the mast can be raised and lowered without the main engine running.

**PRODUCT DESCRIPTION**

**Engine Shutdown Timer**

An optional Engine shutdown timer may also be fitted. This allows a preselectable engine run time of 8, 10, 12 or 14 hours. The timer will commence when the timer switch is turned on and will continue to run for the approximate time selected. At completion of the timed period, the engine will shutdown until the ignition is turned off which resets the system.

**Engine Distress Shutdown System**

An optional Engine Distress Shutdown System may also be fitted to the Light Tower.

This unit is housed in a small black box (early machines) or a grey box (later machines) within the control panel box. The unit monitors high engine temperature, low engine oil pressure, and low coolant level. It will shutdown the Engine if any of the above conditions occur.

The unit is connected to the oil pressure switch in the engine block; a normally open temperature switch in the head which closes above 115 degrees C; and a coolant sensor probe (early machines) or Float level switch (later machines) located in the radiator overflow bottle.

**NOTE:** On early machines fitted with sensor probe. As Glycol is highly resistant, the system is sensitive to a high level of Glycol in the water. Do not exceed 50 percent Glycol to 50 percent water as false triggering may occur.

A mark on the overflow bottle indicates minimum fluid level required in the system.

On later machines that are fitted with a float level switch, a new engine

shutdown module coloured light grey is fitted. This provides improved performance.

**MAINTENANCE PROCEDURES**

**MAINTENANCE PROCEDURES**

Refer to the supplement manual for all service procedures in relation to the Kubota D1403 Diesel Engine.

**IMPORTANT**

**WHEN UNDERTAKING ANY MAINTENANCE OR REPAIR PROCEDURES ON THE LIGHTING TOWER, PARTICULAR ATTENTION SHOULD BE TAKEN ON ALL PROCEDURES INVOLVING WORKING IN, UNDER OR OVER THE MACHINE.**

**THE FOLLOWING GENERAL GUIDELINES SHOULD BE READ AND UNDERSTOOD PRIOR TO CARRYING OUT ANY MAINTENANCE OR REPAIR WORK.**

**General**

The following information is provided to assist you in the use of maintenance procedures contained in this section.

**Safety and workmanship**

Your safety, and that of others, is the first consideration when engaging in the maintenance of equipment. Always be conscious of weight. Never attempt to move heavy parts without the aid of a mechanical device. Do not allow heavy objects to rest in an unstable position. When raising a portion of the equipment, ensure that adequate support is provided.

**Cleanliness**

- (1) The most important single item in preserving the long service life of a machine is to keep dirt and foreign materials out of the vital components. Precautions have been taken to safeguard against this. Shields, covers, seals, and filters are provided to keep air, fuel, and oil supplies clean; however, these items must be maintained on a scheduled basis in order to function properly.
- (2) At any time when air, fuel, or oil lines are disconnected, clean adjacent areas as well as the openings of fittings themselves. As soon as a line or component is disconnected, cap or cover all openings to prevent entry of foreign matter.
- (3) Clean and inspect all parts during servicing or maintenance, and ensure that all passages and openings are unobstructed. Cover all parts to keep them clean. Be sure all parts are clean before they are installed. New parts should remain in their containers until they are ready to be used.

## MAINTENANCE PROCEDURES

### **Components Removal and Installation**

---

- (1) Use adjustable lifting devices, whenever possible, if mechanical assistance is required. All slings (chains, cables, etc.) should be parallel to each other and as near perpendicular as possible to top of part being lifted.
- (2) If a part resists removal, check to see whether all nuts, bolts, cables, brackets, wiring etc., have been removed and that no adjacent parts are interfering.

### **Hydraulic Lines and Electrical Wiring**

---

Clearly mark or tag hydraulic lines and electrical wiring, as well as their receptacles when disconnecting or removing them from the unit. This will ensure that they are correctly reinstalled. Refer to electrical schematics when re-assembling to ensure correct wiring and connections are achieved.

### **Hydraulic System**

---

- (1) Keep the system clean. If evidence of metal or rubber particles are found in the hydraulic system, drain and flush the entire system.
- (2) Disassemble and reassemble parts on a clean work surface. Clean all metal parts with a non-flammable cleaning solvent. Lubricate components as required to aid assembly.

### **Lubrication & Servicing**

---

Components and assemblies requiring lubrication and servicing are listed in the machine's regular maintenance schedule.

Service applicable components with the amount, type and grade of lubricant recommended in this manual, at the specified intervals. When not available, consult your local supplier for an equivalent that meets or exceeds the specifications listed.

### **Battery**

---

Clean battery, using a non-metallic brush and a solution of baking soda and water. Rinse with clean water. After cleaning, thoroughly dry battery and coat terminals with an anti-corrosion compound.

### **Engine Distress Coolant Level Probe (Early Machines)**

---

The engine distress coolant level probe located in the radiator overflow bottle may need periodic cleaning to maintain its effectiveness in sensing coolant level. If false triggering occurs, which will cause the engine to shut down or fail to start, then slide the probe out of the bottle and clean the metal surfaces with a very light abrasive such as a scourers and then reinsert the probe into the bottle.

**MAINTENANCE PROCEDURES**

**CHANGING ENGINE OIL**

Refer to supplement manual on Kubota Diesel Engine for procedures relating to engine oil/filter changes.

**CHANGING FLOODLIGHT LAMPS**

**⚠ DANGER**

**PRIOR TO ATTEMPTING TO REMOVE OR REPLACE THE LAMPS IN THE LAMP FITTINGS, ENSURE THAT THE ENGINE IS SHUT OFF AND THE GENERATOR IS NOT RUNNING.**

**⚠ DANGER**

**DO NOT TOUCH LAMP TERMINALS OR SOCKETS. DANGEROUS VOLTAGES MAY BE PRESENT EVEN WHEN POWER IS OFF. IT IS VERY IMPORTANT TO SWITCH OFF ALL CIRCUIT BREAKERS, EVEN THOUGH THE ENGINE HAS BEEN SHUTDOWN. THIS ISOLATES THE BALLAST CIRCUITS FROM EARTH, PREVENTING A SHOCK HAZARD FROM EITHER LAMP TERMINAL TO EARTH. ALLOW 10 MINUTES FOR BALLAST CAPACITORS TO DISCHARGE BEFORE REPLACING LAMPS. CHECK CAPACITORS ARE BELOW 10VDC BEFORE SERVICE TO LAMP SOCKETS OR BALLAST CIRCUITS BY TRAINED SERVICE PERSONNEL ONLY. SERIES BALLAST CAPACITOR VOLTAGE CAN BE MEASURED ACROSS THE LAMP ASSOCIATED WITH THAT BALLAST USING A 1000 VDC RATED MULTIMETER WITH 1000 VDC RATED SHARP TIP PROBES.**

**⚠ WARNING**

**THE LAMPS AND LAMP FITTINGS BECOME VERY HOT AFTER THEY HAVE BEEN RUNNING. PLEASE ALLOW FOR THE LAMP ASSEMBLY TO COOL TO AN ACCEPTABLE TEMPERATURE PRIOR TO ATTEMPTING ANY SERVICE WORK.**

Access to the metal halide lamp is through the front glass shield. Open the glass shield by unlatching the clip on either side of the glass and swinging the shield open on its hinges.

**IMPORTANT**

**APPLICABLE EYE PROTECTION AND GLOVES SHOULD BE WORN TO AVOID INJURY FROM BREAKING GLASS.**

Disconnect the lamp away from the spring-loaded contacts and remove the lamp from the fitting.

A new lamp is installed in the reverse order with particular attention paid to NOT touching or contaminating the surface of the lamp tube during the installation process.

Ensure the tube is correctly seated on the spring contacts at each end.

Close the glass shield and latch on each side.

Start the engine, switch on the lamp and run the unit for 15 minutes to ensure lamp ignites and runs correctly.

**MAINTENANCE PROCEDURES**

**REMOVING FLOODLIGHT ASSEMBLY**

**! DANGER**

**ENSURE ENGINE IS SHUT DOWN PRIOR TO REMOVING FLOOD LIGHTS.**

Prior to removing any of the 4 floodlight assemblies from the light bar, first remove the electrical lead connections at the light bar assembly junction box.

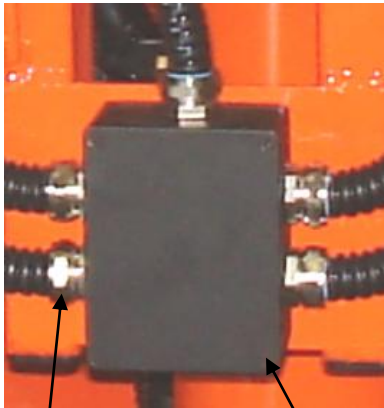

Conduit Glands    Remove Screws

Open the lid of the junction box by removing the 4 screws (6 for 6308AN-6 and 9308AN). Locate the relevant B.P. connectors and loosen the wires. Loosen the steel conduit gland as applicable and withdraw the wire from the gland.

Loosen and remove the nut on the lamp assembly attachment bolt and lower the lamp assembly away from the light bar.

Reinstallation is a reversal of the removal procedure.

**NOTE:** Ensure that the electrical wires are in good condition and reconnected correctly. Pay particular attention to the

connection colours. Refer to the electrical schematic for guidance.

**MAINTENANCE PROCEDURES**

**REMOVING MAST ASSEMBLY**



THE MAST ASSEMBLY ON THE LIGHTING TOWER HAS CONSIDERABLE WEIGHT. USE SUITABLE LIFTING DEVICES WHEN LIFTING HEAVY COMPONENTS. THE USE OF A CRANE AND SUITABLE SLING IS HIGHLY RECOMMENDED.

Prior to removal of the mast assembly, the following steps should be taken.



1. Remove the 4 flood lamp assemblies from the light bar as described earlier.
2. Disconnect and cap the hydraulic hoses at the base of the machine.
3. Disconnect the electrical cabling at the ballast compartment.
4. Loosen and remove the one inch UNC nyloc nut at the base of the mast assembly. Access to this nut is through the gap just above the draw bar at the mast pivot weldment. Take note not to lose the thrust washers as the mast is raised up.

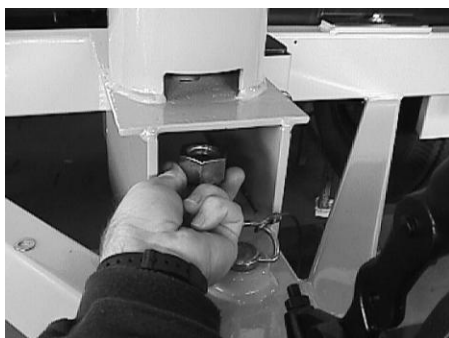

**NOTE:** It is possible to remove the mast assembly with all light assemblies attached, however, the risk of damage to the front glass of the light is possible.

**REPLACEMENT OF AC CIRCUIT BREAKERS**



LETHAL VOLTAGES ARE PRESENT WITHIN THE LIGHT CONTROL BOX ENSURE ENGINE/GENERATOR IS SHUTDOWN PRIOR TO CARRYING OUT ANY ELECTRICAL WORK OR REMOVING ANY PROTECTIVE COVERS.

Remove the cover to the light control box which houses the main circuit breaker R.C.D. and light circuit breakers by loosening the 4 cover mounting screws.

On the breaker to be removed, loosen the screw clamp terminals and remove the wires from the terminals.

With the aid of a flat bladed screw driver, dislodge the clip holding the circuit breaker onto the din rail and remove the breaker from the box.

Replacement of the circuit breaker involves clipping the new breaker into place on the din rail and reconnecting the wires.

**NOTE:** To avoid confusion when reconnecting the wires to a circuit breaker it is advisable that only one circuit breaker at a time be removed and that the wires are suitably labelled prior to removal.

**MAINTENANCE PROCEDURES**

**REMOVE/REPLACEMENT OF LAMP BALLASTS**

The lamp ballasts are located behind the front cover of the lighting tower frame.

**! DANGER**

PRIOR TO ATTEMPTING TO REMOVE THE LAMP BALLASTS, ENSURE THAT THE ENGINE IS SHUT OFF AND THE GENERATOR IS NOT RUNNING.

**! DANGER**

DO NOT TOUCH LAMP TERMINALS OR BALLAST TERMINALS OR SOCKETS. DANGEROUS VOLTAGES MAY BE PRESENT EVEN WHEN POWER IS OFF. IT IS VERY IMPORTANT TO SWITCH OFF ALL CIRCUIT BREAKERS, EVEN THOUGH THE ENGINE HAS BEEN SHUTDOWN. THIS ISOLATES THE BALLAST CIRCUITS FROM EARTH, PREVENTING A SHOCK HAZARD FROM EITHER LAMP TERMINAL TO EARTH. ALLOW 10 MINUTES FOR BALLAST CAPACITORS TO DISCHARGE BEFORE REPLACING LAMPS. ONLY TRAINED SERVICE PERSONNEL SHOULD CHECK THAT CAPACITORS ARE BELOW 10 VDC BEFORE SERVICING LAMP SOCKETS OR BALLAST CIRCUITS BY TRAINED SERVICE PERSONNEL ONLY. SERIES BALLAST CAPACITOR VOLTAGE CAN BE MEASURED ACROSS THE LAMP ASSOCIATED WITH THAT BALLAST USING A 1000 VDC RATED MULTIMETER WITH 1000 VDC RATED SHARP TIP PROBES.

**! WARNING**

THE LAMPS AND LAMP FITTINGS BECOME VERY HOT AFTER THEY HAVE BEEN RUNNING. PLEASE ALLOW FOR THE LAMP ASSEMBLY TO COOL TO AN ACCEPTABLE TEMPERATURE PRIOR TO ATTEMPTING ANY SERVICE WORK. ACCESS TO THE METAL HALIDE LAMP IS THROUGH THE FRONT GLASS SHEILD BY UNLATCHING THE CLIP ON EITHER SIDE OF THE GLASS AND SWIGNING THE SHIELD OPEN ON ITS HINGES.

- First remove the cover by removing the TEK screws holding the cover in place. This will expose the Ballast assemblies.

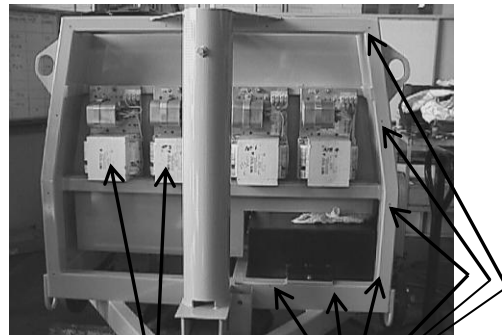

Ballast Assembly x 4

TEK Screws

- Take a note of the wire connections to the ballast to be removed and loosen the screw terminals and remove the wires.
- Loosen and remove the 5/16" nyloc nut holding the top of the ballast in place. Remove the washer and tilt the top of the ballast forward.

## MAINTENANCE PROCEDURES

- Lift the ballast assembly up and out of the lower mounting slot, taking note that the ballast is reasonably heavy.
- Replacement is a reversal of the above removal procedure.

---

### SETTING HYDRAULIC OIL PRESSURE

The hydraulic oil operating pressure is set to 17.23 MPa or 2500 psi.

The pressure is set by adjusting the system relief valve located on the pump/motor assembly.

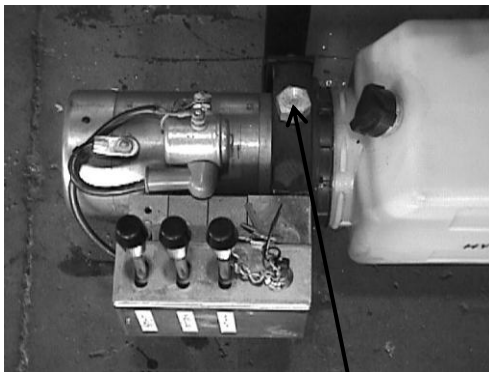

System Pressure Adjustment.

- Remove the Hex cap cover from the valve.
- Connect a suitable pressure gauge to the lift up circuit.
- Operate and bottom out the lift up function.
- While monitoring the pressure gauge continue to operate the lift up function.
- Set the relief valve to the pressure specified above.
- Remove gauge. Reinstall protective cap on relief valve and check system operation.

**FAULT DIAGNOSIS CHART**  
**Lights and Generator Circuit**

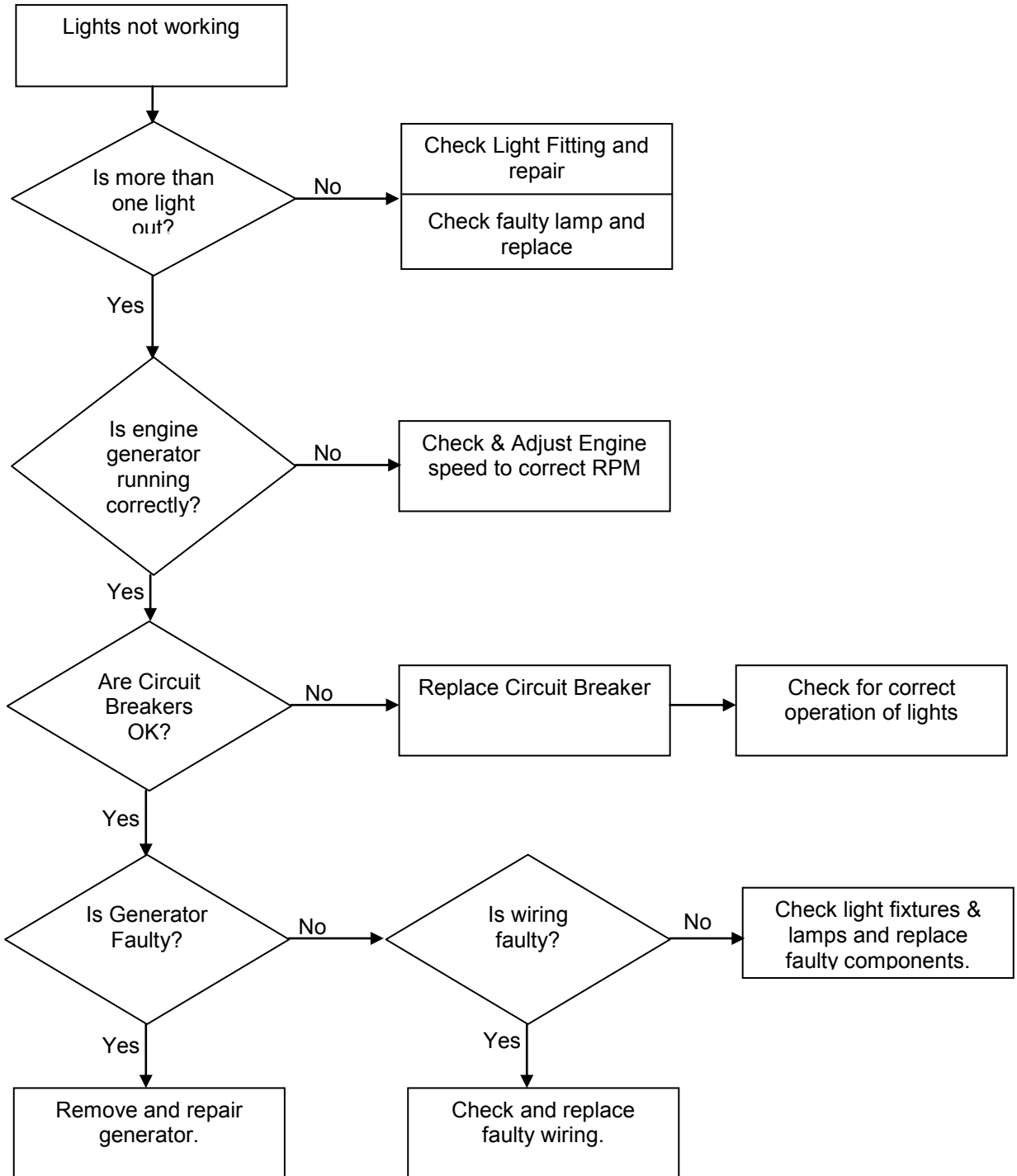

**FAULT DIAGNOSIS CHART**  
**Engine**

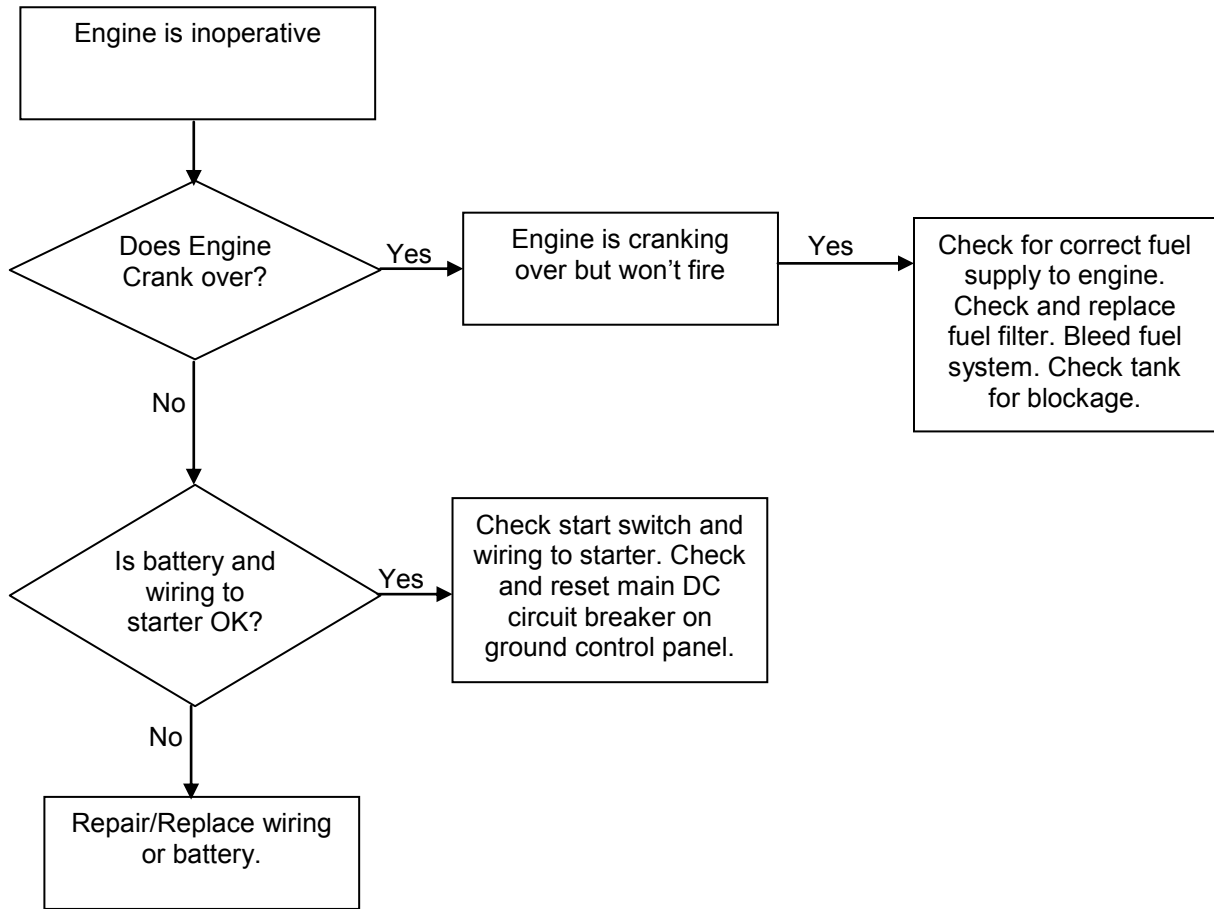

**ELECTRICAL SAFETY TESTS**

The machine needs to have a GPO (or a dedicated RCD test connector) wired to the load side of the 3 phase MCB/RCD to perform the tests (earthing continuity, insulation, and RCD tests).

Machines fitted with a GPO prior to serial # 6308AN222 had the 240v feed for the GPO taken from the alternator side of the MCB/RCD with its own RCD. These machines can easily be modified for testing by qualified electrical personnel by wiring the 240v GPO feed on the load side of the MCB/RCD, and replacing the single phase GPO RCD with a 10 amp 1 pole circuit breaker and 1 module width blank plate.

**DANGER!**

**DO NOT TOUCH LAMP TERMINALS OR SOCKETS.**

Dangerous voltages may be present even when power is off. Shutdown engine, **SWITCH OFF ALL CIRCUIT BREAKERS**, and allow 10 minutes for ballast capacitors to discharge before replacing lamps. Check capacitors are below 10vdc before service to lamp sockets or ballast circuits by trained service personnel only.

Ballast safety tests

Ballast safety tests should be carried out by trained personnel, using suitable test equipment, at 6 monthly intervals. Before testing, turn off all circuit breakers, shutdown engine, and allow lamps to cool. Wait at least 10 minutes after switch off to allow capacitor discharge before testing ballast circuits –

1. Ballast circuits insulation test – Switch the 3 phase RCD/MCB on and the GPO switch on. To test the GPO neutral is connected correctly, check the resistance between earth and neutral at the GPO (with a multimeter) is less than 1 ohm. Switch the 3 phase MCB/RCD off, and with the GPO switch still on, measure insulation resistance at 500vdc between neutral and earth at the GPO (or dedicated test connector). This should be greater than 1 Mohm (typically >100Mohm). If the GPO is not wired on the load side of the 3 phase MCB/RCD, neutral is best accessed by removing the front panel of the electrical switchboard.
2. Ballast capacitor discharge resistor test –
  - a) Residual voltage across ballast capacitors - Open the glass cover on one of the lamp housings. Using a digital multimeter with 1000vdc rated sharp tip test probes, measure the voltage across the lamp globe on the 200vdc range. The reading should be less than 0.5vdc (typically zero). If the voltage measured is greater than this, one or both of the capacitor discharge resistors on the associated ballast is faulty and that capacitor should be replaced. Remove the ballast compartment cover, and on the associated ballast, discharge each capacitor individually using a 1000v rated test lead with sharp tipped probes. Confirm with a voltmeter that the voltage across each capacitor is below 0.5vdc before proceeding to step b.
  - b) Discharge resistor resistance measurement – If the voltage across the lamp measured in step a) was below 0.5vdc, measure the resistance across the lamp with a multimeter set to the 2Mohm range. Each capacitor has a 470Kohm discharge resistor, so the series resistance measured across the lamp should be 940Kohm +/- 10% - ie between 846Kohm (0.846Mohm) and 1,034Kohm (1.034Mohm). Allow a minute or two for the resistance reading to stabilize as the meter current charges the capacitors. Replace any capacitors with faulty discharge resistors.
  - c) Repeat the test for each lamp circuit.

## ELECTRICAL SAFETY TESTS

### Alternator voltage tests

AC voltage tests should be done every 1000 hours or 12 months by trained personnel with suitable test equipment. Voltage tests should not be done with any faulty lamp circuits switched on. Abnormal loading by a faulty ballast or lamp can cause variations in engine speed and voltage.

Before starting the tests, remove the front panel from the switchboard. Check the bottom engine pulley and make sure it has a timing mark suitable for optical tachometer registration. Check that the tacho is functioning correctly by starting the engine and measuring RPM. Double check the tachometer accuracy with a frequency meter plugged into the GPO before any adjustments are made during the test procedures below. Multiply AC frequency x 30 to calculate engine RPM. 50Hz AC corresponds to 1500RPM.

1. Switch all lamps on. Allow the engine and lamps to reach operating temperature (1/4 hr).
2. Loaded engine speed - Engine revs under full load should be between 1500 and 1550 RPM.
3. Loaded voltage – Using a digital multimeter with 1000vac rated probes on the 600vac or 1000vac range, measure between active and neutral for each phase on the MCB/RCD. The loaded voltage on each phase should be between 230vac and 250vac.
4. Unloaded engine speed – Switch all 4 lamp circuit breakers off, but leave the engine running. Engine speed should be between 1530 and 1600 RPM
5. Unloaded voltage measurement – With the engine still running from step 3, the unloaded voltage should be between 230vac and 250vac. The alternator does not reach its true unloaded voltage after each start up until it has first been run under load.
  - a) If both engine speeds are high, and both voltages are high, adjust the engine speed down to the correct setting ie 1550 RPM unloaded. Go back to step 5 and recheck that the unloaded voltage is within the acceptable range. If it isn't, go to step 5 d). If it is, allow time for the lamps to cool (20min after switch off) and go back to step 1 to repeat the voltage test.
  - b) If the engine speeds are low, and the voltages are low, adjust the engine speed up to the correct setting ie 1550 RPM unloaded. Go back to step 5 and recheck that the unloaded voltage is within the acceptable range. If it isn't, go to step 5 d). If it is, allow time for the lamps to cool (20min after switch off) and go back to step 1 to repeat the voltage test.
  - c) If the loaded and unloaded engine revs are more than 50 RPM different, there is abnormal loading (AC current to each ballast should be apx 6.9amps), or the governor on the diesel engine is not functioning correctly.
  - d) If the engine speeds are good, but both voltages are too high or too low, the open circuit voltage on the alternator needs to be reset. Consult the alternator manual and Meccalte in SA or JLG Industries (Australia) in Port Macquarie NSW for the correct procedure. Do not operate the lamps until the open circuit voltage is correctly set. Use a 2400w test load plugged into the GPO to load the alternator for a few seconds before measuring the unloaded voltage out of the alternator during the adjustment procedure. Repeat the voltage tests after the alternator adjustment.
  - e) If the engine speeds are good, but the difference between unloaded and loaded voltages is too great, the alternator load compensation setting and the open circuit voltage setting may need to be adjusted. Consult the alternator manual and Meccalte in SA or JLG Industries (Australia) in Port Macquarie NSW for the correct procedure. Do not operate the lamps until the open circuit voltage is correctly set. Use a 2400w test load plugged into the GPO to load the alternator for a few seconds before measuring the unloaded voltage out of the alternator during the adjustment procedure. Repeat the voltage tests after the alternator adjustments.

**6308AN 6308AN-6 8308AN 9308AN**

**REGULAR MAINTENANCE SCHEDULE**

Item	Daily	50hrs	100hrs	200hrs	400hrs	500hrs	Yearly	1500hrs	3000hrs	20000hrs
Check Engine Oil Level	K,P									
Check Radiator Coolant Level	K,P									
Check Machine for damage/leaks	K,P									
Check Decals Legible	K,P									
Check all controls function as per manual	K,P									
Check RCD operation			K,P							
Change Engine oil		*		K		P				
Check tyre pressure		K,P								
Clean Air Cleaner element			K			P				
Check battery water level			K,P							
Check fan belt tightness	P		K							
Check radiator hoses clamps				K		P				
Replace oil filter cartridge					K	P				
Replace fuel filter cartridge					K	P				
Drain clean fuel tank.						K,P				
Clean & flush radiator cooling system.						K,P				
Replace Air cleaner element.							K,P			
Check valve clearance.							K,P			
Check fuel injection for correct operation.								K,P		
Check fuel injection pump.								K,P		
Bleed brake hydraulic system.								K,P		
Mast rotate mechanism lift/tilt cylinder bushes grease.					K,P					
Outrigger legs locking pins – check free operation, lubricate with WD40 or equivalent.				K,P						
Check mast pins bushings for wear.						K,P				
Check fuel injection timer									K,P	
Check tow hitch and safety chains for secure operation				K,P						
Check chassis frame for cracks and damage.						K,P				
Replace alternator bearing										K,P
Check tyres for wear, splits, damage.				K,P						
Visual check of all electrical wires and connections for damage.				K,P						
Lights are in place, secure and undamaged.	K,P									

K = Kubota Engine Lighting Tower

P = Perkins Engine Lighting Tower

\*1<sup>st</sup> oil change after 50hrs, subsequent oil changes at every 200hrs. Kubota engine only.

Note: For other specific maintenance requirements refer to the OEM manual for that component.

HYDRAULIC SCHEMATIC

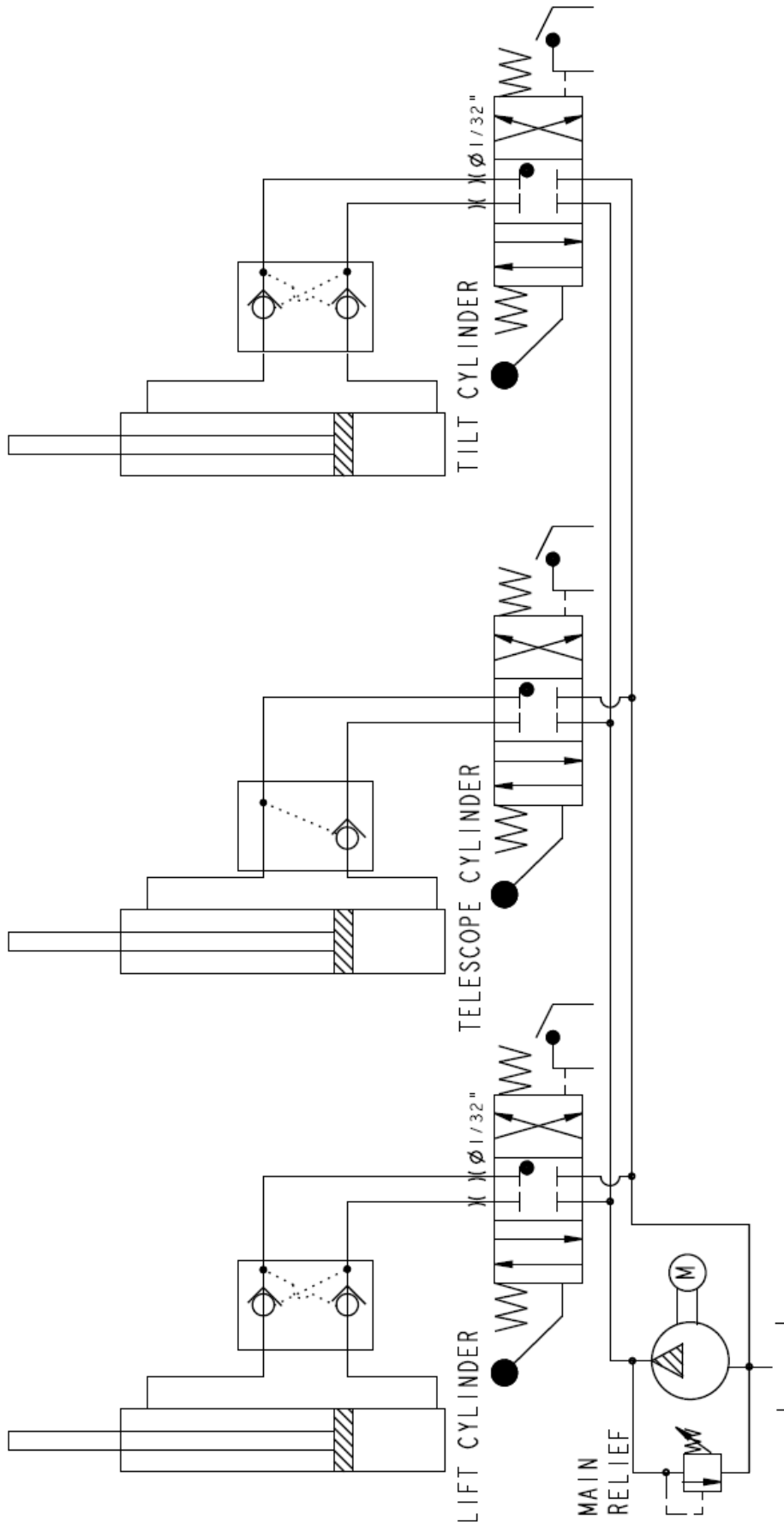

**ELECTRICAL SCHEMATIC – AC – 6308AN & 8308AN**

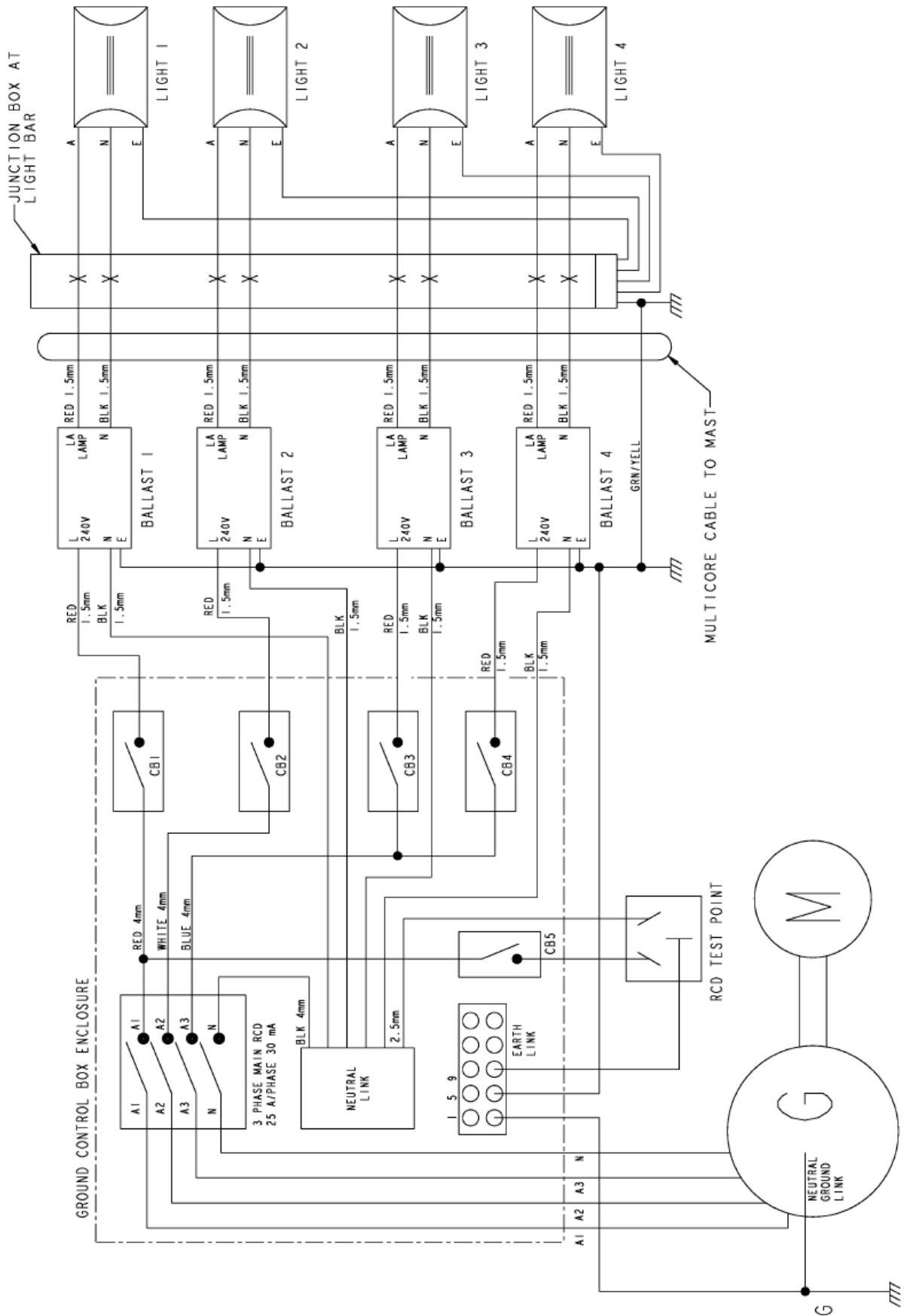

**ELECTRICAL SCHEMATIC – AC – 6308AN-6 & 9308AN**

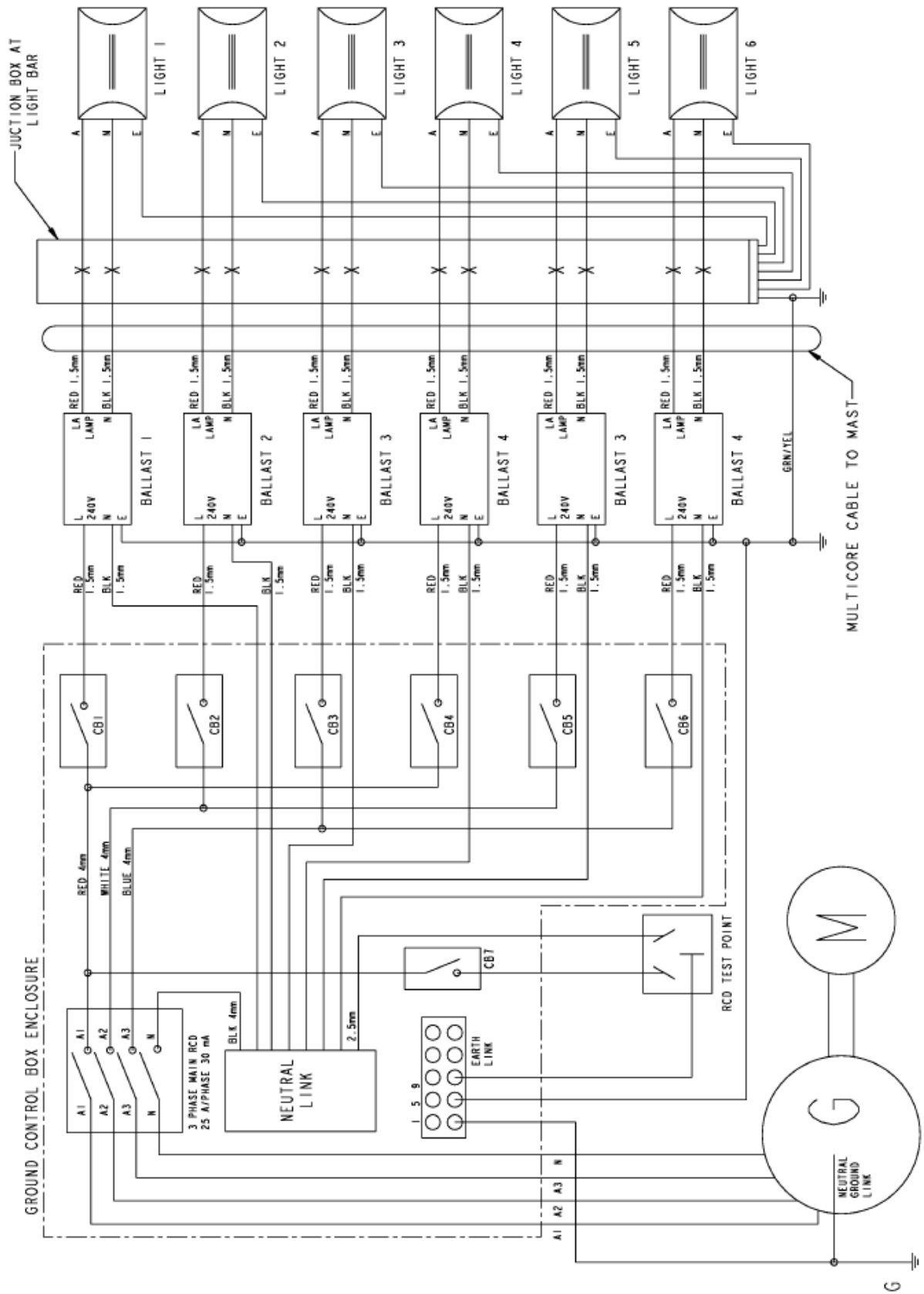

**ELECTRICAL SCHEMATIC - DC**

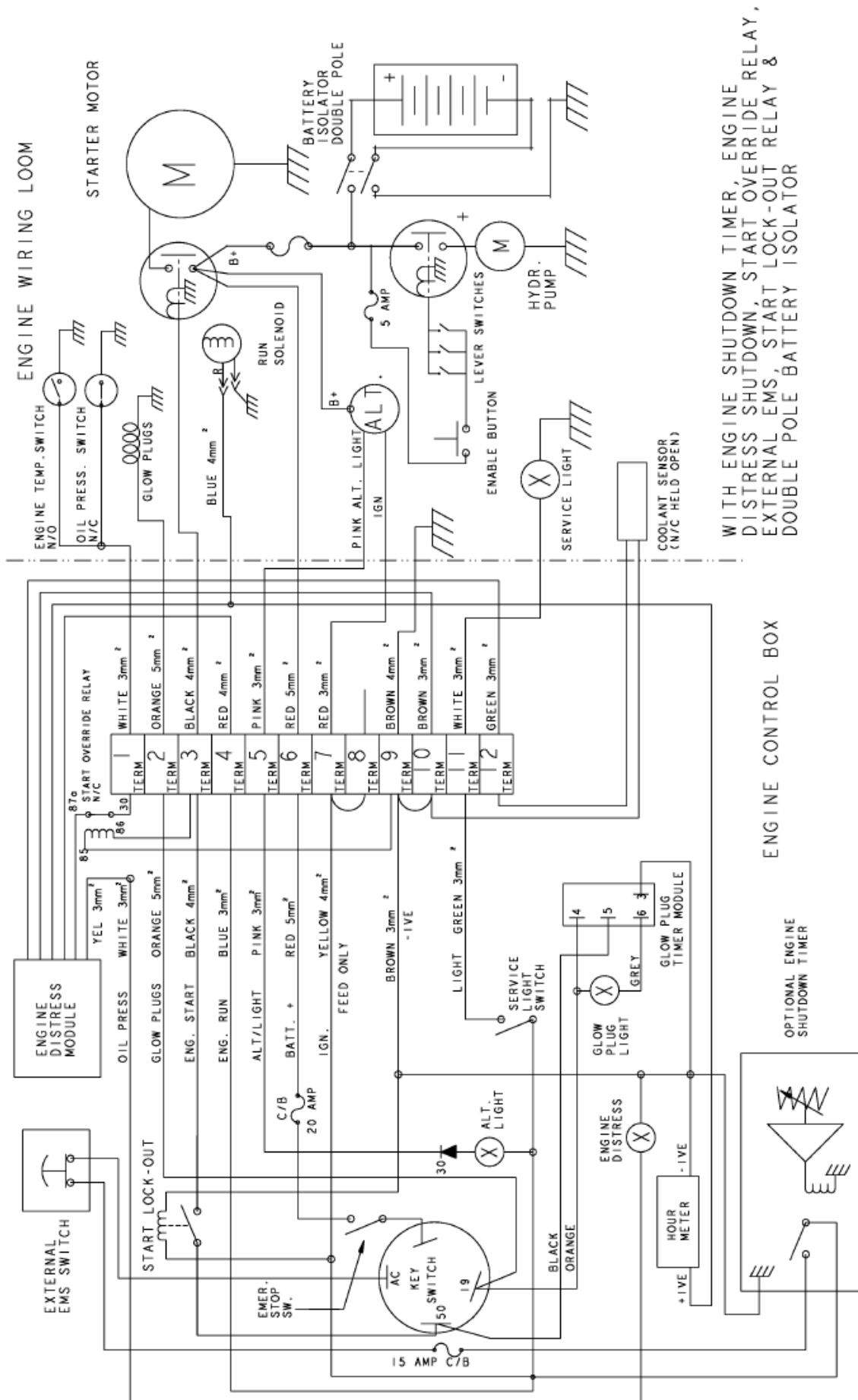

WITH ENGINE SHUTDOWN TIMER, ENGINE DISTRESS SHUTDOWN, START OVERRIDE RELAY, EXTERNAL EMS, START LOCK-OUT RELAY & DOUBLE POLE BATTERY ISOLATOR

## SECTION THREE

### ILLUSTRATED PARTS MANUAL

#### CONTENTS

• MACHINE LEFT SIDE VIEW	3-1
• MACHINE RIGHT SIDE VIEW	3-4
• MACHINE FRONT VIEW	3-5
• MACHINE REAR VIEW	3-8
• HYDRAULIC CONTROLS AND PUMP	3-9
• LIGHTS CONTROL BOX	3-11
• ENGINE CONTROL BOX	3-13
• KUBOTA ENGINE – LEFT SIDE	3-15
• KUBOTA ENGINE – RIGHT SIDE	3-17
• KUBOTA V2203 ENGINE ADDITIONALS	3-18
• PERKINS ENGINE – LEFT SIDE	3-19
• PERKINS ENGINE – RIGHT SIDE	3-22
• ALTERNATOR, BATTERY & BATTERY ISOLATOR SWITCH	3-23
• MAST ASSEMBLY	3-25
• CYLINDERS	3-27
• LIGHT BAR ASSEMBLY	3-30
• 6308AN & 8308AN FLOODLIGHT ASSEMBLY	3-31
• 6308AN-6 & 9308AN FLOODLIGHT ASSEMBLY	3-33
• OTHER CHASSIS COMPONENTS	3-35
• RADIATOR BOTTLE + DOOR GAS STRUTS	3-37

**MACHINE LEFT SIDE VIEW**

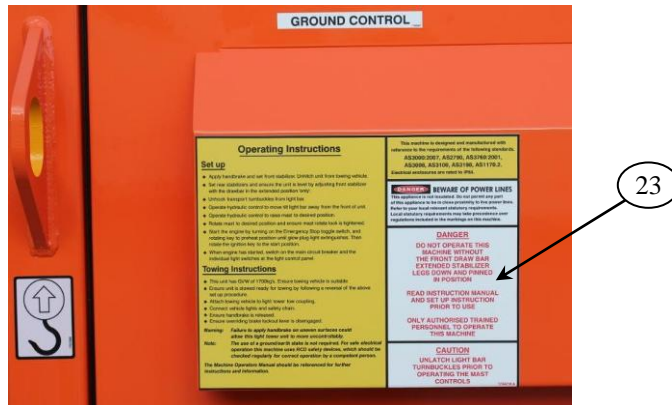
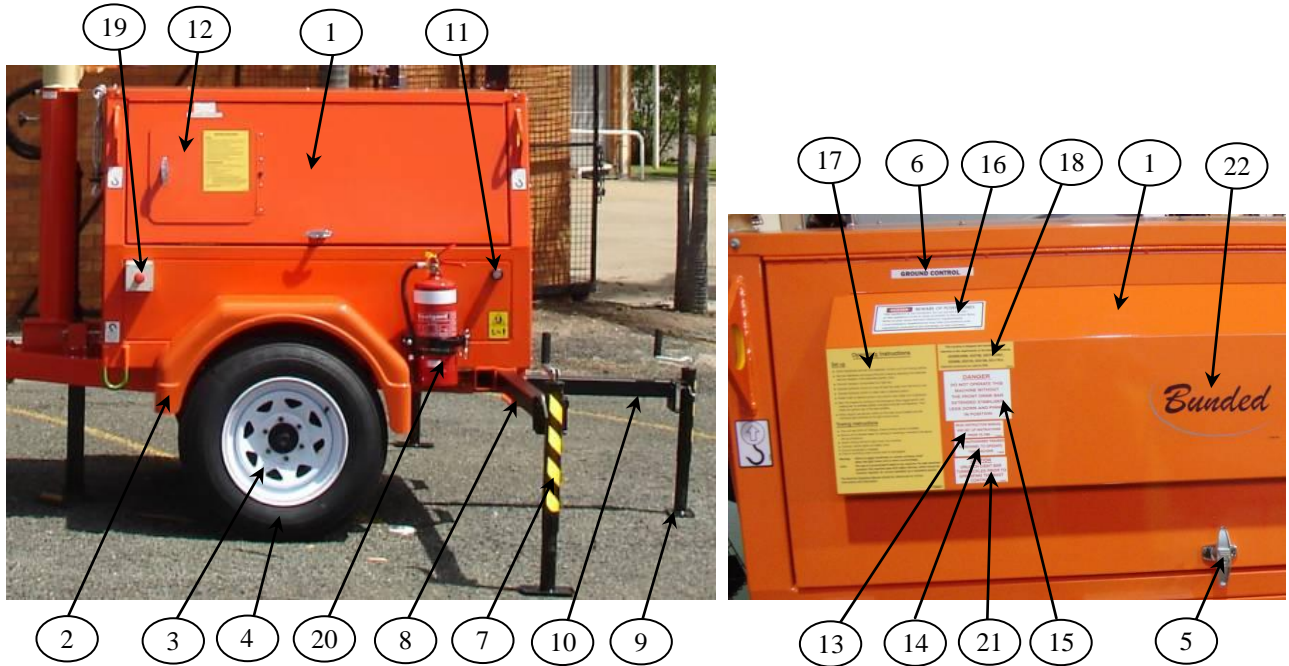

Item	Part Number	Qty	Description of Part
1	1730705	1	Door LH Side Assembly (Series I only)
	1733280	1	Door with Vent Assembly LH
2	1730829	1	Guard LH Side Fibreglass (Prior to S/N 6308AN1840)
	1734233	1	Mudguard Shield Finished LH (S/N 6308AN1840 to Present)
3	1730603	2	16" x 6J Wheel Rim
	1730618	2	205/80 x 16" Tyre
5	1730529	2	Handle Lock Door (3 for Series I Machines)
	1730790	2	Handle Locking Tab (3 for Series I Machines)
	1730916	2	Coates Door Lock (Coates Spec) (3 for Series I Machines)
	1730033	2	Padlock Handle & S Bracket (Coates Spec)
6	1700037	1	Decal 'Ground Control'
7	A330010	2	Outrigger Side Jack Assembly
8	1730533	2	Outrigger Side Extension Arm
	1734353	2	Outrigger Side Extension Arm (6308AN-6 & 9308AN only)
9	1730777	1	Outrigger Rear Jack Assembly (Series I only)
10	1730749	1	Outrigger Rear Extension Arm (Series I only)
	1734354	1	Outrigger Rear Extension Arm (6308AN-6 & 9308AN Series I only)
	1733737	1	Outrigger Rear Extension Arm (6308AN-6 & 9308AN Series II only)

**6308AN 6308AN-6 8308AN 9308AN**

11	1730750	2	Block Stop Stabilizer Storage
12	1730820	1	Access Door (Series I only)
13	1730596	1	Decal 'Only Authorised Trained Personnel' (Prior to S/N 6308AN2015)
14	1730597	1	Decal 'Read Instruction Manual' (Prior to S/N 6308AN2015)
15	1730598	1	Decal 'Do Not Operate Unless Outrigger Legs Down' (Prior to S/N 6308AN2015)
16	1736529	1	Decal 'Danger Beware of Power Lines' (Prior to S/N 6308AN2015)
17	1730831	1	Decal 'Operating Instructions' (Prior to S/N 6308AN2015)
18	1730734	1	Decal 'Standards compliance' (Prior to S/N 6308AN2015)
19	4360475	1	Emergency Stop Switch
	1733231	1	Single Gang Junction Box Base (GWR)
	1733047	1	Single Gang Junction Box Cover (GWR)
	1730574	1	Single Gang Enclosure (Clipsal)
20	1730853	1	Fire Extinguisher 9kg (Option)
	1733395	1	Fire Extinguisher 9kg Mount Bracket (Option)
	1734123	1	Fire Extinguisher 4.5kg
	1733394	1	Fire Extinguisher 4.5kg Mount Bracket
	1733802	1	Fire Extinguisher 1kg
21	1730535	1	Decal 'Unlatch Light Bar' (Prior to S/N 6308AN2015)
22	1734174	2	Decal 'Bunded' (Series II)
23	1734218	1	Decal 'Operating Instructions & Danger' (S/N 6308AN2015 to Present)

**This page left blank intentionally**

**MACHINE RIGHT SIDE VIEW**



Item	Part Number	Qty	Description of Part
1	1730611	1	Door RH Side Assembly (Series I only)
	1733764	1	Door with Vent Assembly RH
2	1730830	1	Guard RH Side Fibreglass (Prior to S/N 6308AN1840)
	1734232	1	Mudguard Shield Finished LH (S/N 6308AN1840 to Present)
3	1701500	4	Decal Tie Down/Lift
4	1702300	2	Decal Tie Down
5	1701785	2	Crushing Hazard
6	1734185	1	Decal 'Engine Oil and Bunding Drain' (Series II)
7	1734046	1	Tap, BSP 1/4" (Series II)
8	1733735	2	Urethane Wheel Chock (Option)
9	1733736	2	Wheel Chock Mount Bracket (Option)

**MACHINE FRONT VIEW**

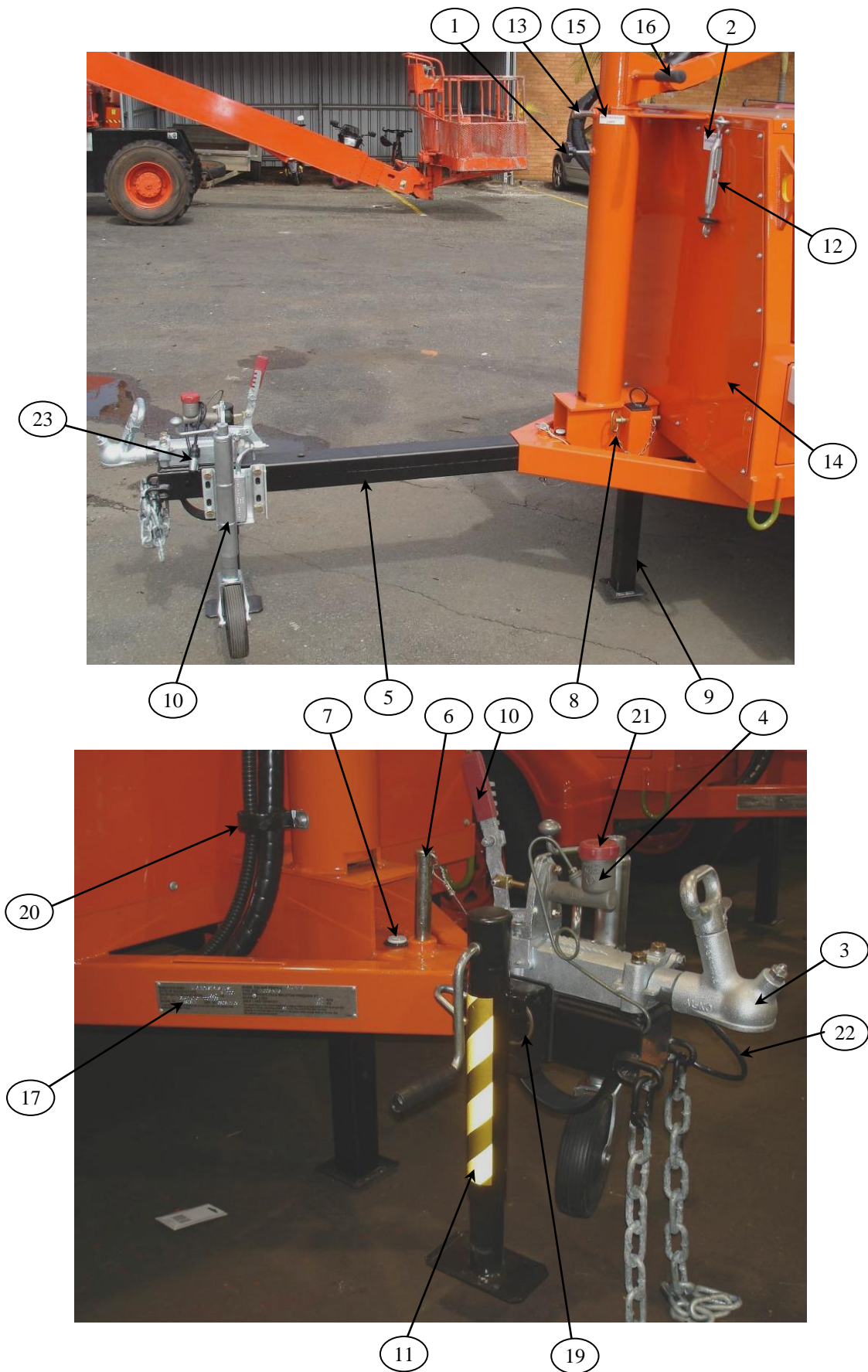

<b>Item</b>	<b>Part Number</b>	<b>Qty</b>	<b>Description of Part</b>
1	A620550	1	Mast Rotate Locking Knob (Prior to S/N 6308AN1464)
	1734165	1	Mast Rotate Locking Knob (S/N 6308AN1464 to Present)
2	1730599	1	Decal – Maximum Voltage Within Enclosure
3	1735456	1	Tow Coupling – Override Tow Ball Type
4	1737060	1	Cylinder Hydraulic Brake
5	1730901	1	Weldment Front Drawbar Extension
6	1733267	1	Drawbar Pin Assembly
7	1733106	1	Bubble Level
8	1733192	1	Transport Leg Hitch Pin
	1733193	1	Transport Leg Pin Chain
9	1730580	1	Transport Leg Weldment
10	1730952	1	Jockey Wheel
11	A650235	1	Front Outrigger Jack
12	1730759	2	Eye Bolt
	1730760	2	Turn Buckle
	1730773	2	Rubber Bumper Turnbuckle
13	3422744	1	Pin Plunger
14	1001171811P	1	Front Panel (finished)
15	1730747	1	Decal Mast Rotation Lock
16	1730797	1	Mast Rotate Handle Grip
17	1737103	1	Decal ‘Vin Plate Identification’
18	1730578	1	Brake Handle Park Brake
19	A330014	4	Outrigger Circlip
20	1320219	3	Hose Clamp 2½” Steel P Clip
21	1734707	1	Cap Hyd Brake Reservoir
22	1730520	6m	5 Core Trailer Cable
23	1737066	1	7 Pin Small Round Metal Trailer Plug
	1730881	1	7 Pin Large Round Metal Trailer Plug (Coates Vic Spec)
	1730863	1	7 Pin Flat ‘Quickfit’ Trailer Plug (Coates NSW Spec)
	1730894	1	7 Pin Large Round Metal Trailer Socket (Coates Qld Spec)

**This page left blank intentionally**

**MACHINE REAR VIEW**



**6308AN Series I**

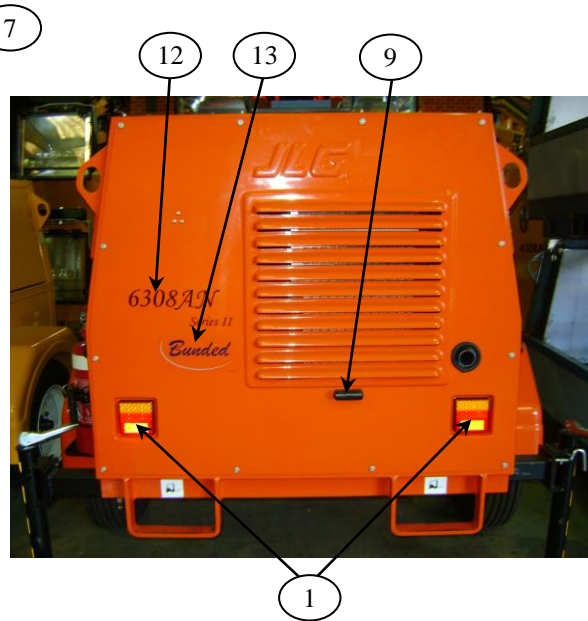

**6308AN Series II**

Item	Part Number	Qty	Description of Part
1	1733618	2	Tail Light Assembly
	1733980	1	Lamp Bulb 12V 21/5W (Brake)
	1730951	1	Lamp Bulb 12V 21W (Blinker)
	1734145	2	Tail Light Assembly L.E.D.
2	1730819	1	Decal Rear Outrigger (Prior S/N 6308AN268) (Not Shown)
3	1703073	2	Decal 'Forklift Pocket'
4	1730534	1	Mast Support Cradle
5	1730617	1	Decal '6308AN' (Series I only)
6	1732597	1	Wear Pad, Main Boom
7	1001144507	1	Rear Panel
	1001144809	1	Rear Panel (Series II Kubota D1403 Engine)
	1731328	1	Rear Panel (Series II Perkins 403D-11 Engine) (finished)
8	1730606	1	Roof Panel (Series I Kubota D1403 Engine)
	1730949	1	Roof Panel (Series I Kubota D1703 Engine)
	1734541	1	Roof Panel (Series I Perkins 403D-11 Engine)
	1733335	1	Roof Panel (Series II) (finished)
9	1730914	1	Licence Plate Lamp (S/N 6308AN269 to Present)
	1730593	1	Number Plate Light Narva (Prior S/N 6308AN268)
10	3422369	2	Outrigger Extension Arm Lock Pin
11	1730735	1	Muffler Guard (Series I)
12	1734186	1	Decal '6308AN Series II' (Series II)
13	1734174	2	Decal 'Bunded' (Series II)

**MAST HYDRAULIC CONTROLS AND PUMP**

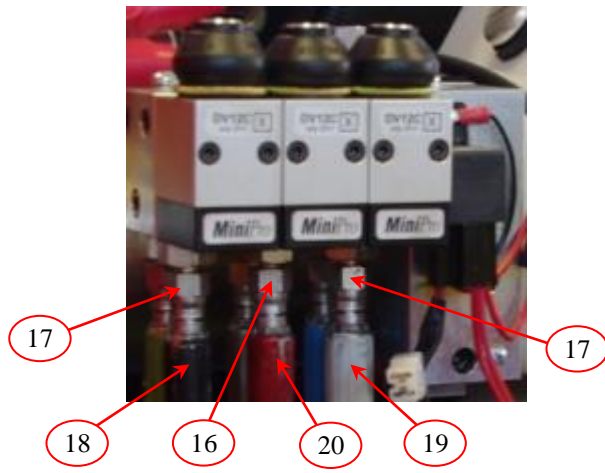
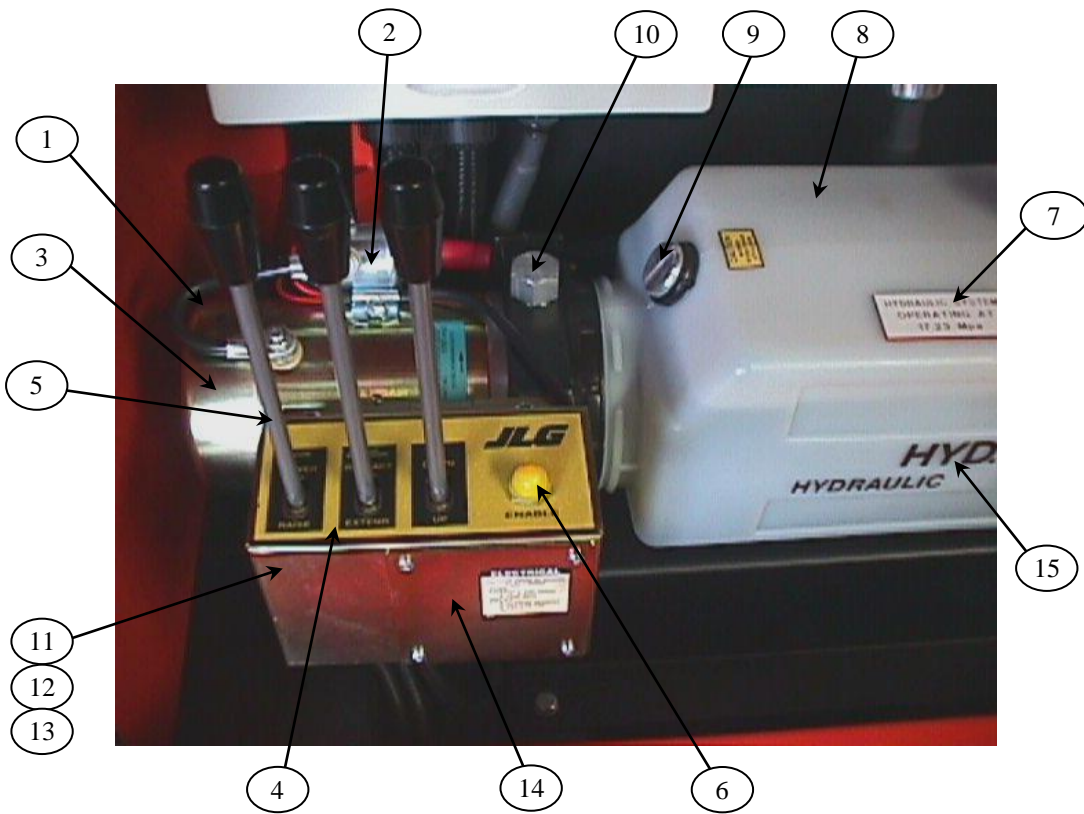

Item	Part Number	Qty	Description Of Part
1	1730543	1	Power Pack Assembly Complete Fenner
2	1730549	1	Solenoid Motor Run 12V
3	1730583	1	Electric Motor
4	1730726	1	Decal 'Lift, Tele, Tilt'
5	1730548	3	Control Lever with Knob
6	4360387	1	Switch Pushbutton. Hydraulic Enable
7	1730547	1	Decal 'Hydraulic System Operating at 17.23 MPa'
8	1730854	1	Oil Reservoir
9	1730855	1	Filler/Breather Cap
10	1730856	1	Relief Valve Kit (with Relief Valve, Load Check and Plug)
11	1730857	3	Complete Directional Control Valve (with Handle, Valve Block, Boot, Spring Mechanism, Switch and Spool)

12	1730858	3	Boot Kit (with Boot, Boot Gland and Boot Spring)
13	1730859	3	Handle Actuator Switch Kit (with Switch, Mounting Plate and Screws)
14	1730860	1	Metal Valve Cover
15	1700419	1	Decal 'Hydraulic Oil'
16	1734248	2	Nipple M/M with Encapsulated Seal ¼ x 7/16
17	1734249	4	Nipple M/M with Encapsulated Seal and Orifice ¼ x 7/16
18	1733346	2	Lift Cylinder Hose Assembly
19	1733347	2	Tilt Cylinder Hose Assembly
20	1733348	2	Tele Cylinder Hose Assembly

LIGHT CONTROL BOX

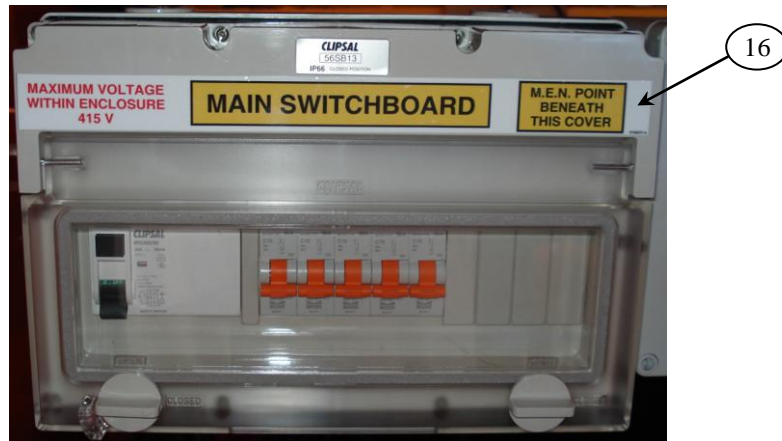
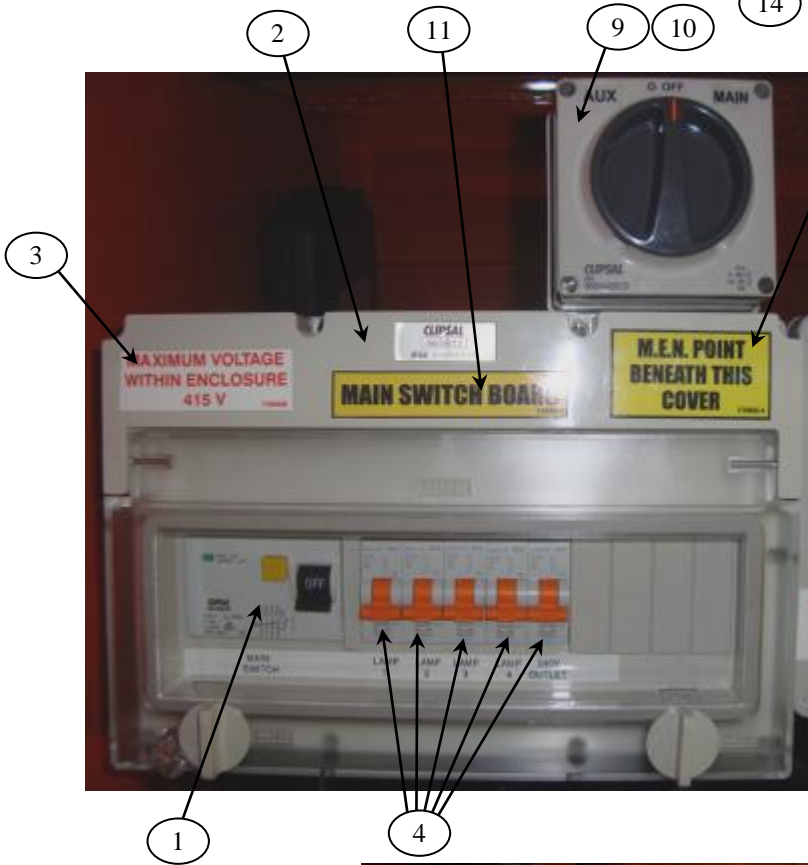
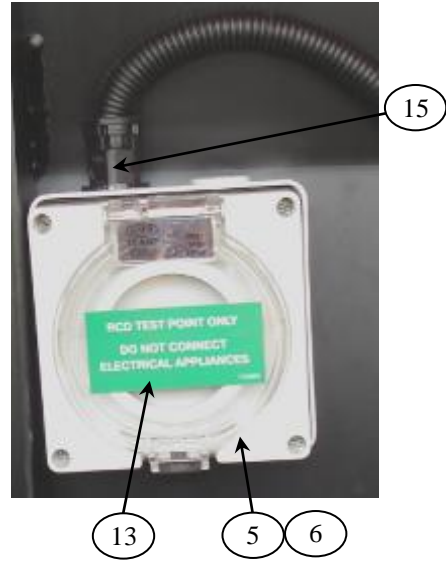

**ENGINE CONTROL BOX**

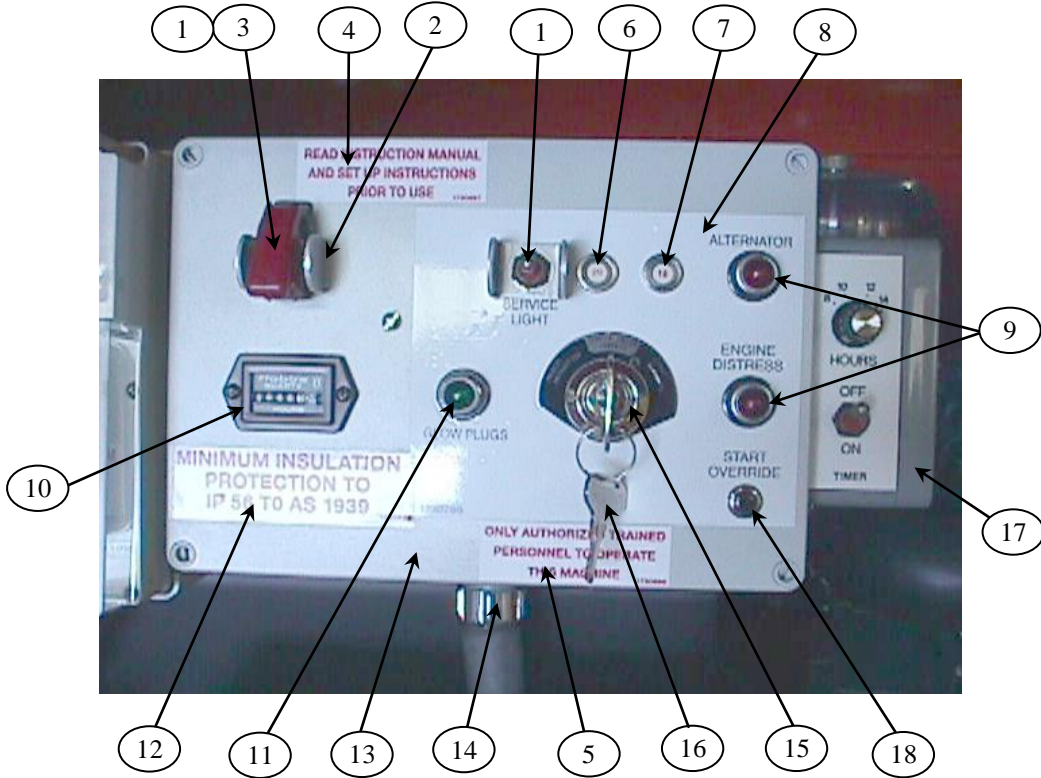

Item	Part Number	Qty	Description of Part
1	4360199	2	Toggle Switch SPST
2	4060229	1	Shield Toggle Switch
3	4360141	1	Emergency Stop Switch Guard
4	1730597	1	Decal 'Read Instruction Manual' (Prior to S/N 6308AN2015)
5	1730596	1	Decal 'Authorised Trained Personnel' (Prior to S/N 6308AN2015)
6	4360070	1	Circuit Breaker 15 Amp Push to Reset
7	4360161	1	Circuit Breaker 20 Amp Push to Reset

8	1730537 1730798	1 1	Decal Control Panel (Prior to S/N 6308AN081) Decal Control Panel (S/N 6308AN081 to S/N 6308AN2014)
9	2920026 2920029	2 2	Lamp Red Lamp Bulb
10	2420165 2420172	1 1	Hourmeter Gauge (Prior to S/N 6308AN1734) Hourmeter Gauge (S/N 6308AN1734 to present)
11	2920027 2920029	1 1	Lamp Green Lamp Bulb
12	1730538	1	Decal 'Minimum Insulation Protection' (Prior to S/N 6308AN2015)
13	1001146366	1	Enclosure Engine Control
14	4460051	1	Terminal Gland Connector
15	1730540 1732656 1734435	1 1 1	Ignition KeySwitch+Keys Control Box Kubota (option) Ignition KeySwitch+Keys Control Box Lucas (option) Ignition KeySwitch+Keys Control Box Perkins (option)
16	1730541 1730550	1 1	Ignition Key - Control Box Kubota Engine (option) Ignition Key – Control Box Perkins Engine (option)
17	1730700 1730674 1734141 1734142	1 1 1 1	Engine Shutdown Timer 14 HR (Option) Decal, Shutdown Timer 14 HR Engine Shutdown Timer 16 HR (Option) Decal, Shutdown Timer 16 HR
18	1730800	1	Override Switch (Prior to S/N 6308AN081)
19	1733240	1	Decal, Ground Control Box (S/N 6308AN2015 to Present)
<b>Other 12V DC Components (Not Shown)</b>			
	1730787	1	Engine Distress Shutdown Module (Inside Box) (Prior to S/N 6308AN303)
	1730924	1	Kubota Engine Distress Shutdown Module (Grey Box) (S/N 6308AN303 to Present)
	1001141724	1	Perkins Engine Shutdown Module
	1735347	1	Terminal strip located inside box
	1730542	1	Glow Plug Timer Module
	3740086	1	Start Lockout Relay
	3740085	1	Start Lockout Relay Base
	1734099	1	Start Override Relay Kit (Later machines without start override switch.)
	1737268	1	Interior Service Light
	1733979	1	Interior Service Light Bulb



<b>Item</b>	<b>Part Number</b>	<b>Qty</b>	<b>Description of Part</b>
1	1730621	1	Main RCD Clipsal 4RC425/30
2	1730624	1	Clipsal Enclosure 56SB13
3	1730536	1	Decal 'Maximum voltage 415V' (Prior to S/N 6308AN2015)
4	1730622	5	Single Pole Circuit Breaker
	1730197	5	Double Pole Circuit Breaker (Clipsal)
	1733227	5	Double Pole Circuit Breaker (Pulset)
5	1730836	1	Auto Switched Outlet (Clipsal)
	1733228	1	Auto Switched Outlet (GWR)
6	1733231	1	Single Gang Enclosure Base
7	1750106	1	Neon Cover (Clipsal)
	1733230	1	Neon Cover (GWR)
8	1750104	1	3 Gang Enclosure Base (Clipsal)
	1733229	1	3 Gang Enclosure Base (GWR)
9	1730998	1	Triple Pole Switch (Option)
10	1735107	1	Single Gang Enclosure Base (Clipsal) (Option)
11	1734017	1	Decal 'Main Switch Board' (Prior to S/N 6308AN2015)
12	1730832	1	Decal 'M.E.N Point Beneath this Cover' (Prior to S/N 6308AN2015)
13	1730925	1	Decal 'RCD Test Point Only'
14	1730623	1	RCD Circuit Breaker G.P.O. Wilco RCBM210/30 (Option)
15	1733216	3	M20 to M16 Nylon Gland
16	1734217	1	Decal, AC Powerbox (S/N 6308AN2015 to Present)
<b>Other 240V Components Not Shown</b>			
	1735066	1	25-20 Reducer
	1733215	3m	25mm Nylon Conduit
	1733214	1m	16mm Nylon Conduit
	1733217	2	M25 to M25 Nylon Gland
	1320224	1	Cable Clamp
	1737284	1	GPO Clipsal 56C310D (Option)
	1730862	6	Earth Tag for Steel Conduit Swivel Fitting (Option)

**KUBOTA ENGINE - LEFT SIDE**

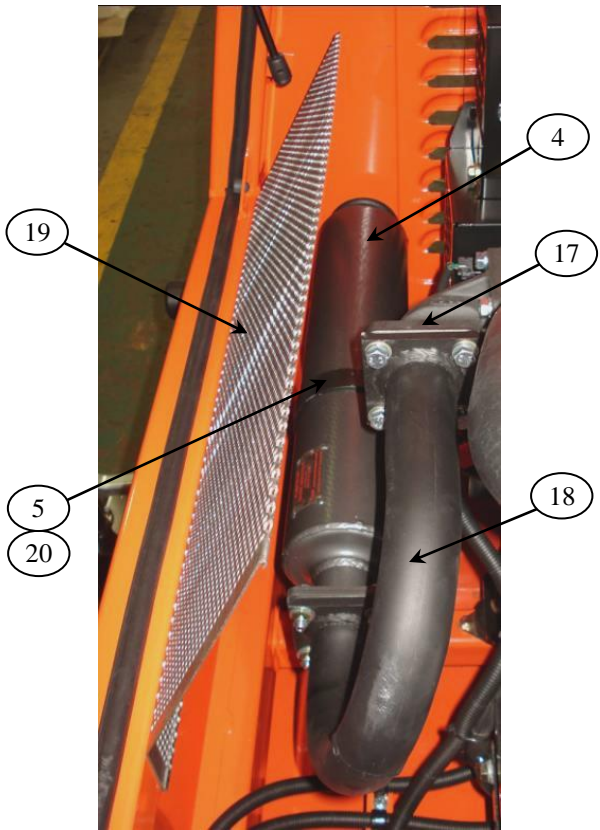
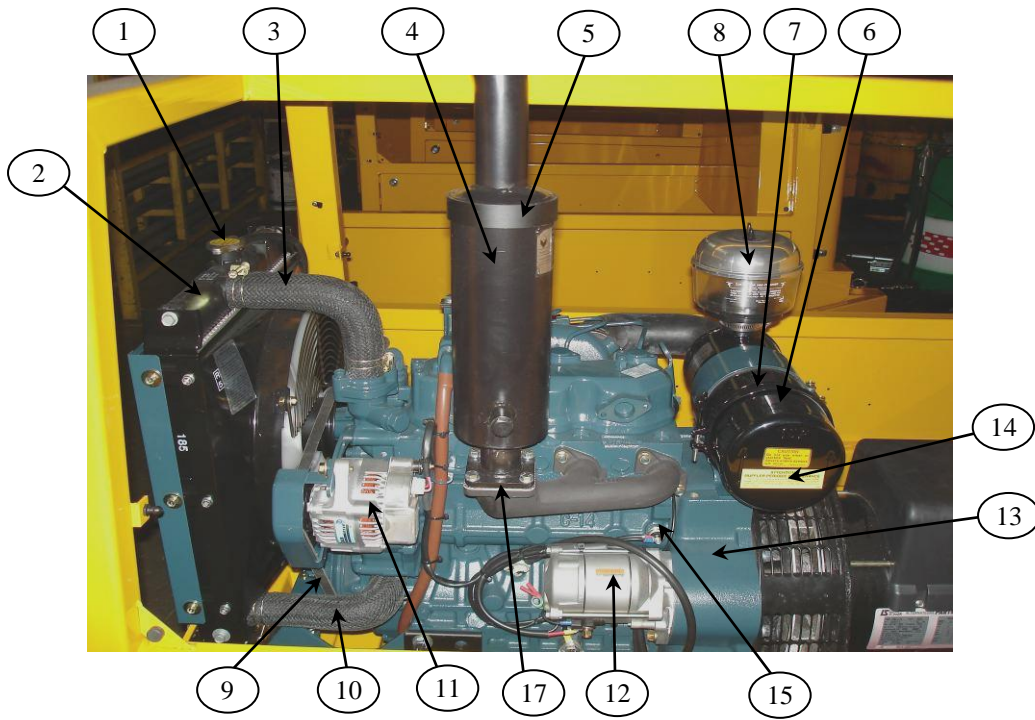

**S/N6308AN1464 to S/N6308AN2276**

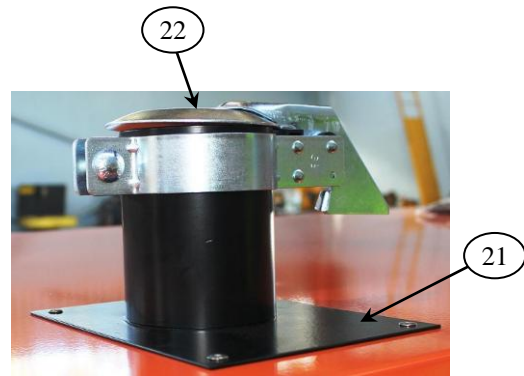

**S/N6308AN2277 to Present**

<b>Item</b>	<b>Part Number</b>	<b>Qty</b>	<b>Description of Part</b>
1	1730562	1	Radiator Cap Overflow. Carparts N1000
2	1730865	1	Radiator D1403
3	1730867	1	Radiator Hose Top D1403
4	1730765	1	Muffler Spark Arrestor (Prior to S/N6308AN2277)
	1001145528	1	Kubota Spark Arrestor Muffler (S/N6308AN2277 to Present)
5	1730817	1	Muffler Support Clamp Stainless
	1734334	1	Muffler Clamp
6	1730869	1	Air Filter Assembly D1403
7	1730565	1	Air Filter Element D1403
8	1730768	1	Pre-cleaner Fleetguard (Donaldson)
9	1730870	1	Fan Belt D1403
	1734836	1	Fan Belt Guard Upper (Option)
	1734835	1	Fan Belt Guard Lower (Option)
10	1730868	1	Radiator Hose Lower D1403
11	1730558	1	Alternator 12V Denso
12	1730871	1	Starter Motor D1403
13	1730725	1	Engine Kubota D1403 (6308AN& 6308AN-6)
	1730826	1	Engine Kubota D1703 (8308AN)
	1734289	1	Engine Kubota V2203 (8308AN & 9308AN)
14	1730947	1	Decal Muffler Periodic Maintenance
15	1730874	1	Oil Pressure Sender D1403
16	1730724	1	Rain Cap, Standard Muffler (Not Shown)
17	1733520	1	Exhaust Gasket
18	1733290	1	Rear Exhaust Pipe Kubota (Series II Prior to S/N6308AN2277)
19	1734178	1	Exhaust Deflector Shield Plate (Series II Prior to S/N6308AN2277)
20	1733329	1	Muffler Bracket Kubota Rear Exhaust (Series II Prior to S/N6308AN2277)
21	1733241	1	Exhaust Shroud Weldment (S/N6308AN2277 to Present)
22	1001141759	1	3 1/2" Exhaust Rain Cap (S/N6308AN2277 to Present)

**KUBOTA ENGINE – RIGHT SIDE**

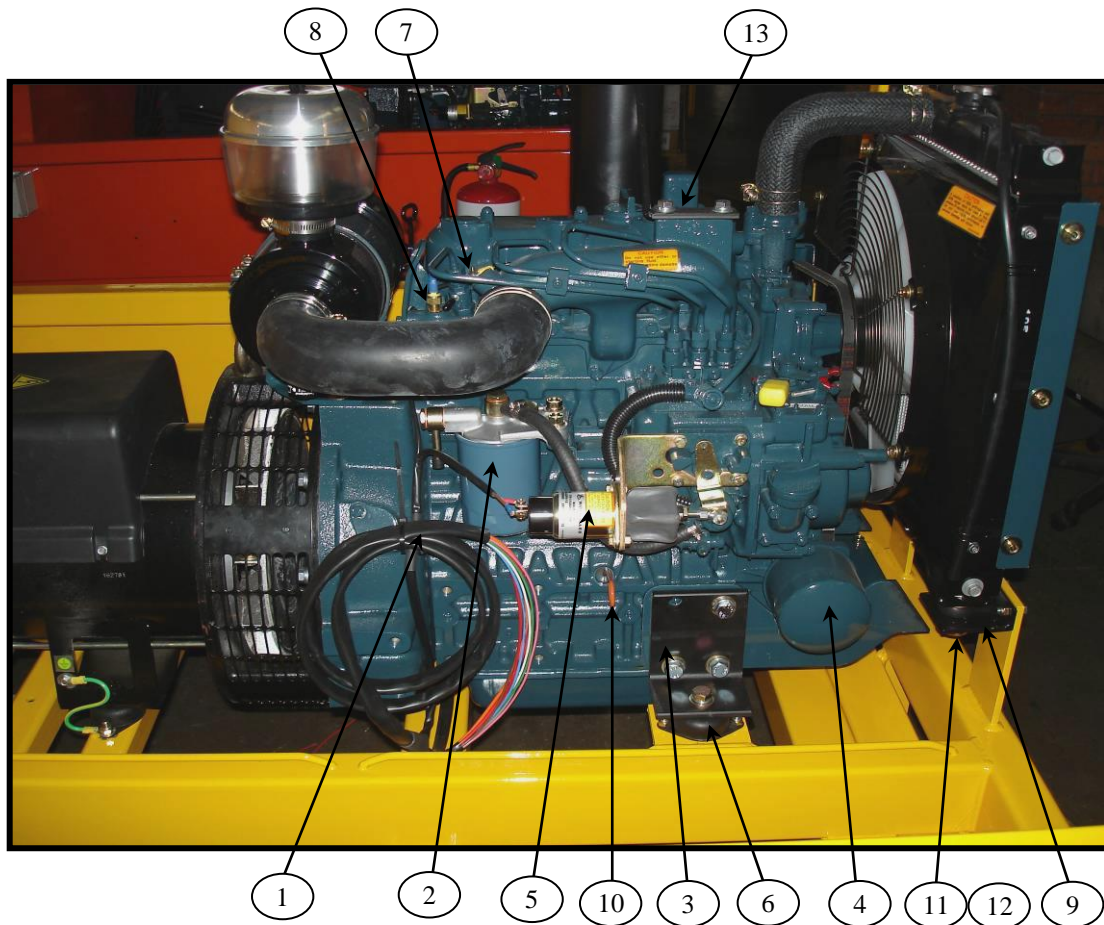

Item	Part Number	Qty	Description of Part
1	1730567	1	Engine Loom Kubota
2	1730873	1	Filter Fuel D1403
3	1730742	2	Engine Mount Left & Right suit D1403
4	1730569	1	Filter Oil
5	3740074	1	Solenoid Engine Run
6	1730211	4	Rubber Mount, Engine & Generator
	1730595	6	Rubber Mount, Engine & Generator (MeccAlte only)
7	1730875	3	Glow Plugs D1403
8	1730796	1	Engine Temperature Sender D1403
9	1734130	2	Bracket Radiator Mount
10	1730907	1	Engine Dipstick
11	1734127	2	Radiator Mount Top
12	1734126	2	Radiator Mount Bottom
13	1734335	1	Muffler Bracket Upright Kubota (Series I and S/N6308AN2277 to Present)

**KUBOTA V2203 ENGINE ADDITIONAL COMPONENTS**

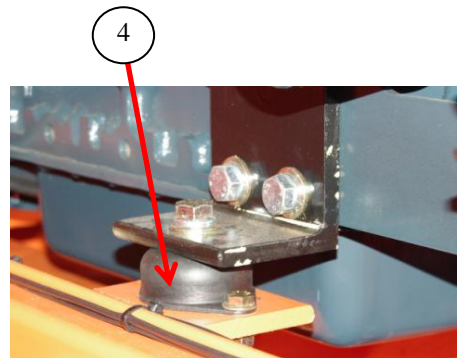
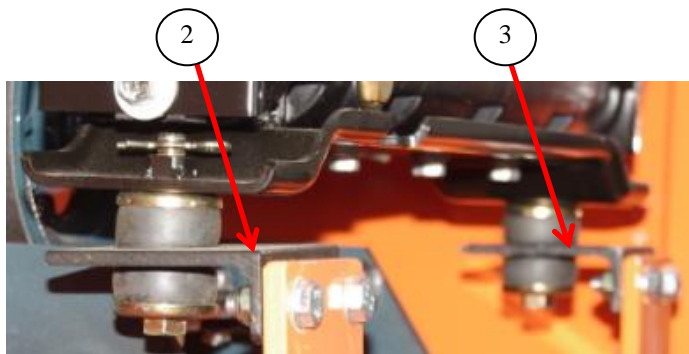

Item	Part Number	Qty	Description of Part
1	1731329	1	Weldment Kubota V2203 Rear Exhaust Pipe (9308ANH Only)
2	1734130	1	Radiator Mount Bracket LH
3	1731326	1	Radiator Mount Bracket RH for Engine V2203 (8308AN & 9308AN)
4	1731335	4	Rubber Mount, Engine V2203 and Alternator (8308AN & 9308AN)

**PERKINS ENGINE - LEFT SIDE**

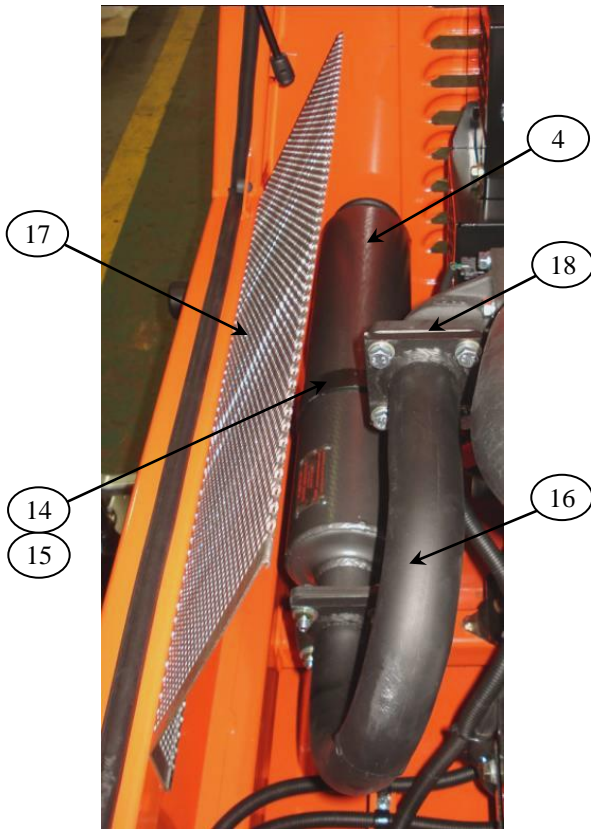
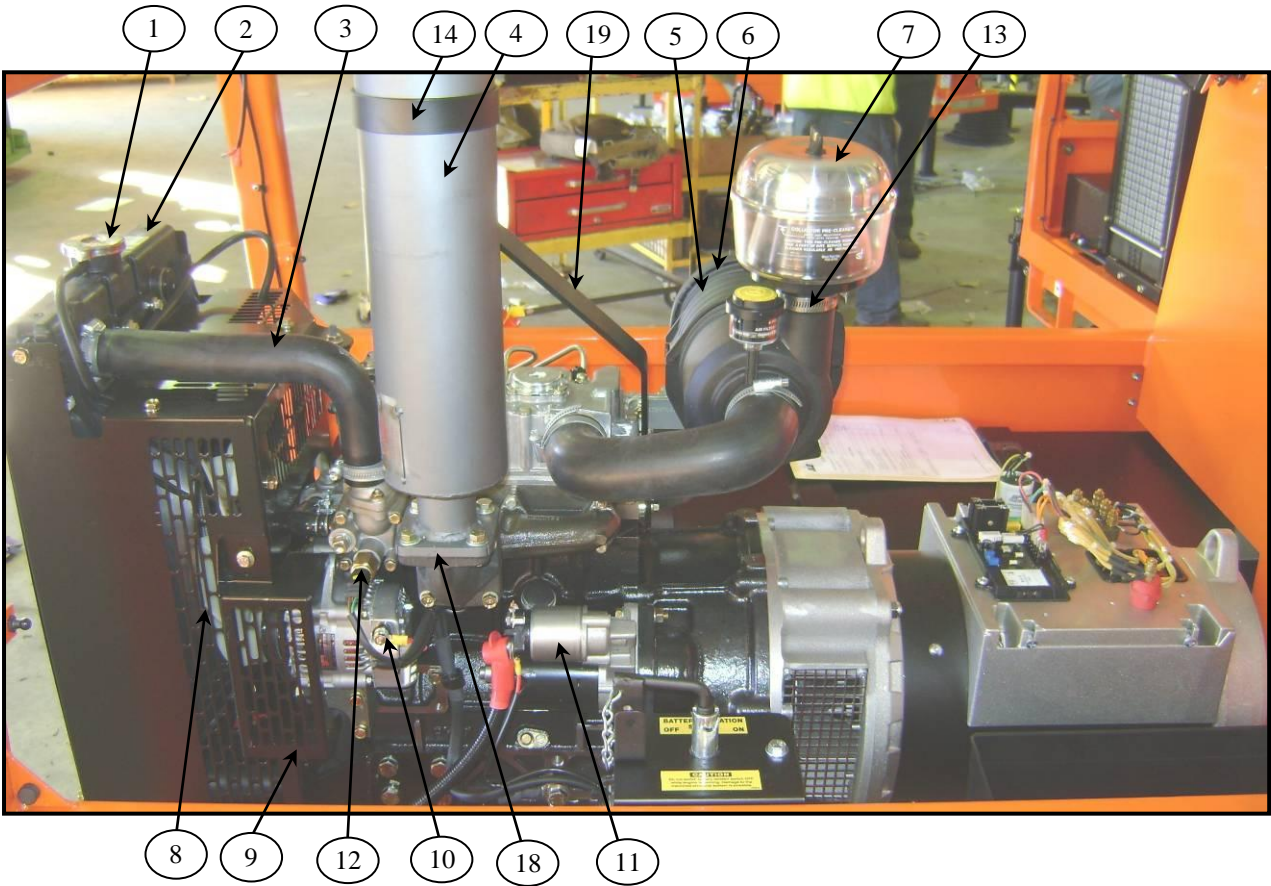

**From S/N6308AN1464 to S/N6308AN2276**

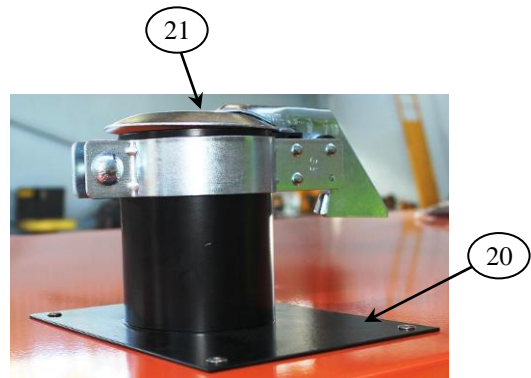

**S/N6308AN2277 to Present**

<b>Item</b>	<b>Part Number</b>	<b>Qty</b>	<b>Description of Part</b>
1	1731748	1	Radiator Cap Overflow
2	1734421	1	Radiator
3	1734422	1	Radiator Hose Top
4	1730765	1	Muffler Spark Arrestor (Prior to S/N6308AN2277)
	1001141797	1	Perkins Spark Arrestor Muffler (S/N6308AN2277 to Present)
5	1734436	1	Air Filter Assembly
6	1734415	1	Air Filter Element
7	1730768	1	Pre-cleaner
8	1734153	1	Fan Belt
9	1734423	1	Radiator Hose Lower
10	1734385	1	Alternator
11	1734382	1	Starter Motor
12	1734381	1	Water Temperature Sender
13	1731350	1	Joiner Rubber Coupling
14	1734334	1	Muffler Clamp
15	1734177	1	Muffler Bracket Perkins Rear Exhaust (Series II Prior to S/N6308AN2277)
16	1734176	1	Rear Exhaust Pipe Perkins (Series II Prior to S/N6308AN2277)
17	1734178	1	Exhaust Deflector Shield Plate (Series II Prior to S/N6308AN2277)
18	1733520	2	Exhaust Gasket (1 for Series I machines)
19	1734336	1	Perkins Muffler Bracket Upright (Series I and 6308AN2277
	1001142697	1	to Present)
20	1733241	1	Exhaust Shroud Weldment (S/N6308AN2277 to Present)
21	1001141759	1	3 1/2" Exhaust Rain Cap (S/N6308AN2277 to Present)

**PERKINS ENGINE – RIGHT SIDE**

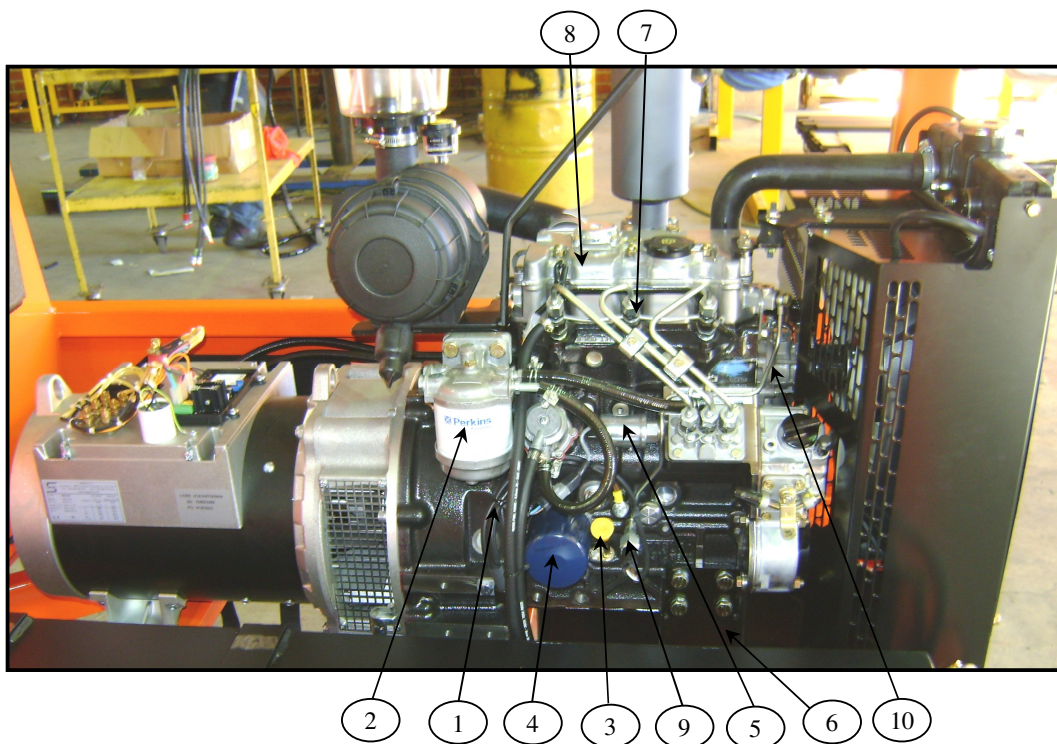

Item	Part Number	Qty	Description of Part
1	1734386	1	Engine Loom
2	1733164	1	Filter Fuel
3	1734383	1	Engine Dipstick
4	1733165	1	Filter Oil
5	1734424	1	Solenoid Engine Run
6	1730211	4	Rubber Mounts
7	1734384	3	Glow Plugs
8	1731747	1	Perkins Engine 403D11
9	1734420	1	Oil Pressure Sender
10	1734425	1	Water Pump
11	1001213257 1001213389	A/R	Kit, Perkins Radiator Mount MR40 Instructions, Retrofit MR40 Kit

**RADIATOR OVERFLOW BOTTLE**

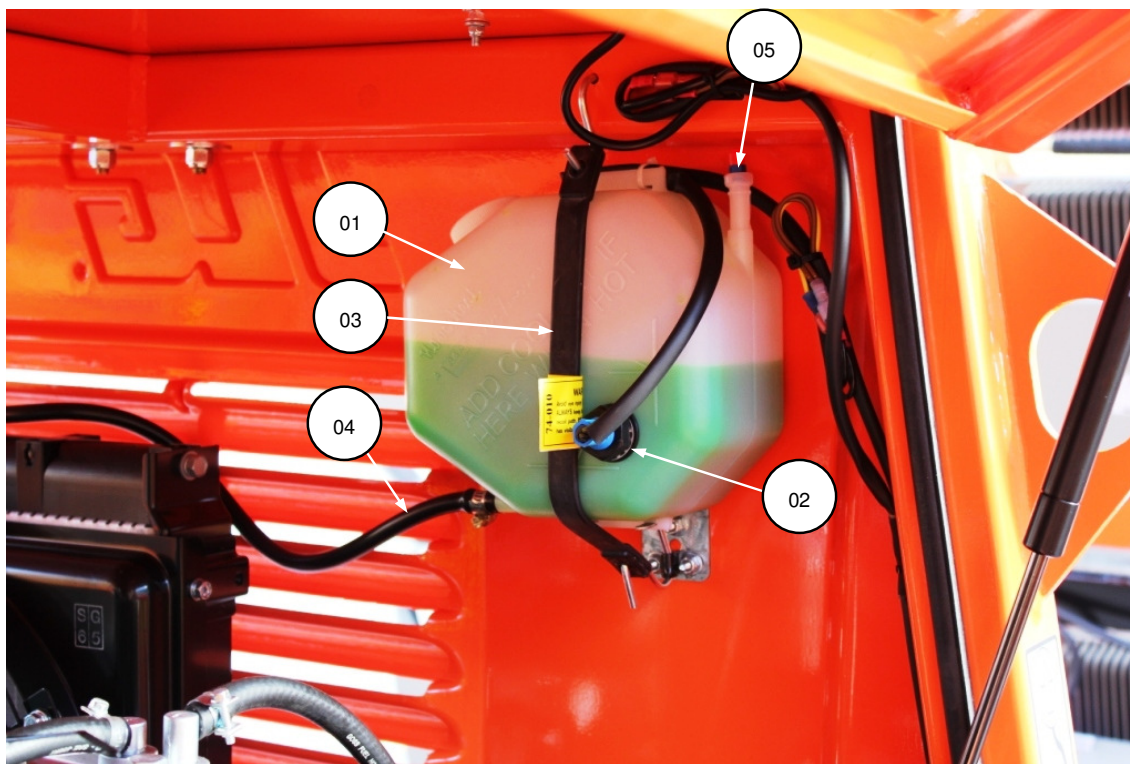

SEQ.#	ITEM NO.	DESCRIPTION	QTY
01	1730785	BOTTLE, RADIATOR OVERFLOW	1
02	1730918	SENSOR, WATER LEVEL	1
	1730919	KIT, WATER LEVEL SENSOR	
03	1730791	KIT, RUBBER STRAP	1
		BRACKET, STRAP MOUNTING	1
		HOOK, STRAP HANGING	2
04	1730785	TUBING, HEADER TANK /RADIATOR	1
05	1320073	P-CLAMP, MODIFIED	1
06	1001175516	CHECK-VALVE, COOLANT BOTTLE	1

**RADIATOR OVERFLOW (HEADER) BOTTLE**

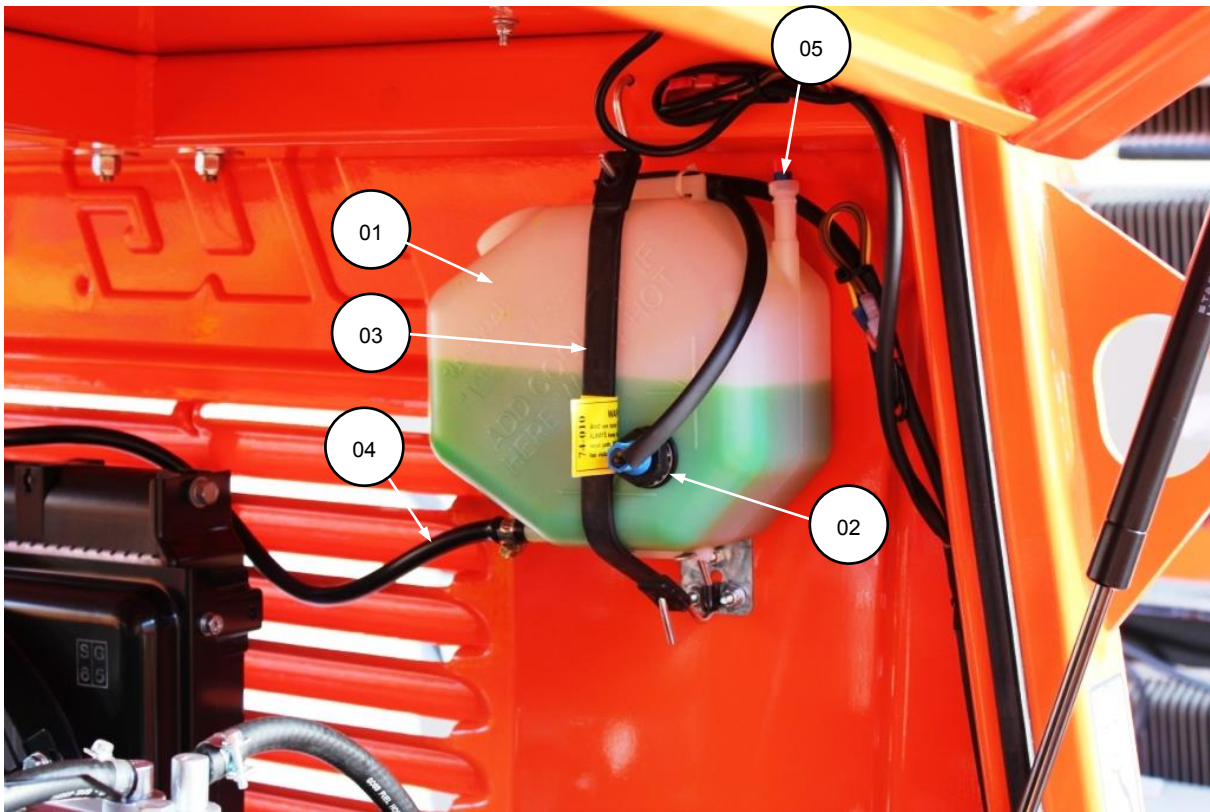

SEQ.#	ITEM NO.	DESCRIPTION	QTY
01	1730785	BOTTLE, RADIATOR OVERFLOW	1
02	1730918 1730919	SENSOR, WATER LEVEL KIT, WATER LEVEL SENSOR	1
03	1730791	KIT, RUBBER STRAP BRACKET, STRAP MOUNTING HOOK, STRAP HANGING	1 1 2
04	1730785	TUBING, HEADER TANK /RADIATOR	1
05	1320073	P-CLAMP, MODIFIED	1
06	1001175516	CHECK-VALVE, COOLANT BOTTLE	1

**ALTERNATOR, BATTERY & BATTERY ISOLATOR SWITCH**



Item	Part Number	Qty	Description of Part
1	0400003	1	Battery 12 V N70ZZ
2	1730727	1	Battery Clamp
3	1731207	1	Battery Tray Standard
4	1730861	1	Battery Box
5	1738283	1	Terminal Battery Lug Positive
6	1734112	1	Battery Terminal Boot Red
7	1738284	1	Terminal Battery Lug Negative
8	1734113	1	Battery Terminal Boot Black
9	1730572	1	Alternator, MeccAlte. Model CT03-2L/4
	1730213	1	Alternator, Sincro 14 kVA HB45AR (Kubota)

	1731750	1	Alternator, Sincro 14 kVA HB45AR (Perkins)
	1730251	1	Alternator, Leroy Somer
	1730253	1	Alternator, Sincro 16.5 kVA (8308AN)
	1734290		Alternator, Sincro 20 kVA (8308AN & 9308AN)
10	1734125	1	AVR Card, Sincro
	1734080	1	AVR Card, Leroy Somer
11	1734109	1	Compound Regulator (MeccAlte)
12	4360155	1	Battery Isolator Switch, Single Pole
	1730847	1	Battery Isolator Switch, Double Pole
13	1730672	1	Bracket, Single Pole Battery Isolator Switch
	1730848	1	Bracket, Double Pole Battery Isolator Switch
14	1734117	1	Single Pole Isolator Lockable Head
15	1733272	1	Double Pole Isolator Handle Weldment
16	1733269	1	Double Pole Battery Isolator Bracket
17	1731126	1	Double Pole Isolator Locking Bracket (Locksafe) (Option)
18	1730772	1	Decal, Battery Isolator Switch
19	1730913	1	Decal, Caution Battery Isolator
20	2400044	1	200 A Fuse Holder
21	2400041	1	200 A Fuse, Motor Starter Supply
22	1733220	1	25 mm to 25 mm 90 deg Adapter
23	1733733	1	Cole Hersee Heavy Duty Starter Assembly (Option)
24	4460618	1	Terminal Anderson 350 A (Option)
25	1737908	1	EMC Filter (Capacitor)
<b>Other Components Not Shown</b>			
	1730832	1	Decal 'MEN Point' Alternator Cover (option)
	1730850	8	Red 8 mm Terminal Boot
	1730851	4	Black 8 mm Terminal Boot
	1730879	4	Red 5 mm Terminal Boot
	1730880	1	Black 5 mm Terminal Boot

**MAST ASSEMBLY**

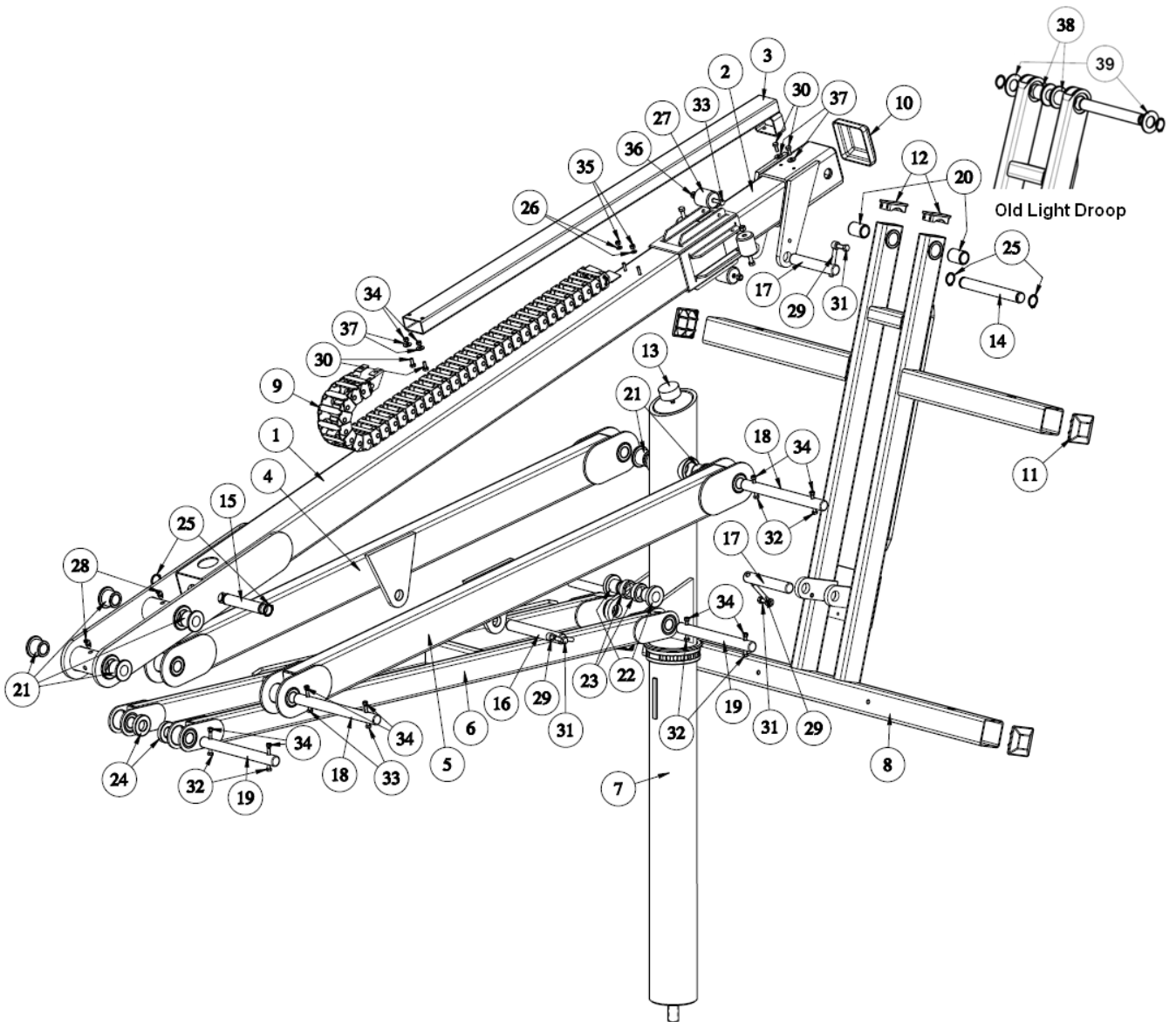

Item	Part Number	Qty	Description of Part
1	1730517	1	Weldment, Mast Upper External
	1734106	1	Weldment, Mast Upper External (Stauff Clamp Spec)
2	1730516	1	Assembly, Mast Upper Inner
3	1730589	1	Weldment, Cable Carrier Tube
4	1730514	1	Weldment, Inner Link Arm LH
5	1734352	1	Weldment, Inner Link Arm RH
6	1730515	1	Weldment, Outer Link Arms
	1734105	1	Weldment, Outer Link Arms (Stauff Clamp Spec)
7	1730661	1	Weldment, Lower Inner Mast
8	1734190	1	Weldment, Light Droop MKII
9	1734586	1	Assembly, Cat Track
10	1730814	1	Cap, Inner Mast Galvanize
11	1730812	4	End Cap, Light Bar 65x65
12	1731360	2	End Cap, Light Bar 65x35 (Scalloped)
13	1730778	1	Rubber Bumper, Mast Park
14	1001173862	1	Pin, Light Droop Pivot

15	1001173863	1	Pin, Tele-Cylinder Lower Pivot
16	1001173774	1	Pin, Lift-Cylinder Pivot
17	1001173864	2	Pin, Tilt-Cylinder Pivot
18	1001173773	2	Pin, Inner Link Arm Pivot
19	1001173772	2	Pin, Outer Link Arm Pivot
20	1731306	2	Bush, Light Droop MKII
21	1730511	2	Bush, Mast Upper Brass
22	1730513	2	Boss, Cylinder to Lower Mast
23	1730614	1	Pin, SS 1" Dia. 185mm Long
24	1734299	2	Spacer, Double Pivot
25	7011716	4	Ring Snap, Pedal Retaining
26	4811700	2	Washer, 6mm
27	1730710	4	Roller, Mast Carrier
28	1731087	2	Fitting, Grease , 45 Deg. 1/8 NPT
29	3841143	3	Keeper, 3/8" Shaft
30	0641405	4	Hex Hd Cap Screw, 1/4-20 x 5/8 LG
31	0641608	3	Hex Hd Cap Screw, 3/8-16 x 1 LG
32	0641416	6	Hex Hd Cap Screw, 1/4-20 x 2 LG
33	0641522	4	Hex Hd Cap Screw, 5/16-18 x 2 3/4 LG
34	1734309	10	Nut, Nyloc 1/4
35	3290605	2	Nut, Nyloc M6 x 1 TPI ZP
36	1734471	4	Nut, Nyloc 5/16
37	4751400	4	Washer, 1/4 Dia. Plain Stl., Wide
38	1730615	2	Bush, Mast Upper Inner (Old Light Droop)
39	1734053	1	Washer, 1" Plain Stl., Narrow (Old Light Droop)
<b>Other Mast Assembly Components (Not Shown)</b>			
	1702009	3	Decal 'JLG' 3 1/2"
	1730521	24	Conduit Clamp, Plastic (option)
	1735514	14	Stauff Clamp, 2 x 12mm Plastic (option)
	1737913	5	Stauff Clamp, Steel Plate (option)
	1737914	5	Stauff Clamp, Base Plate (option)

**CYLINDERS**

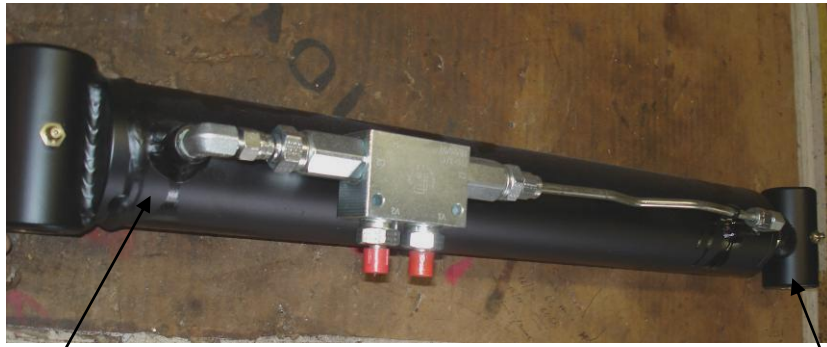

2 Bale Cylinder (Pin Eye Welded to Rod) 3

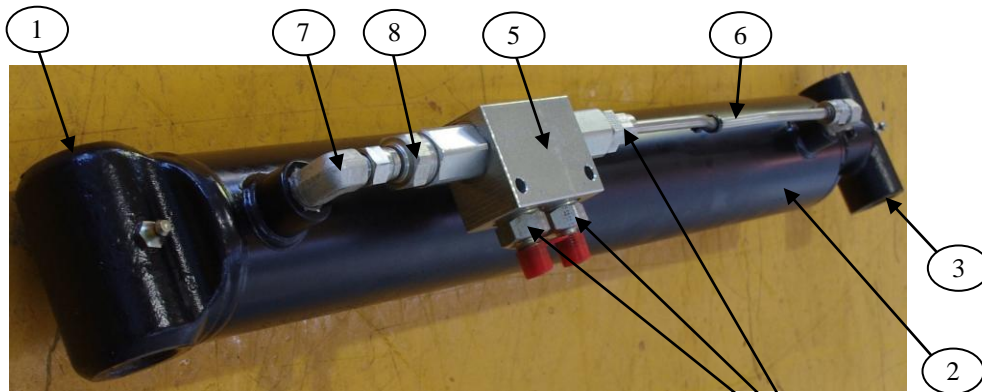

Nordon Cylinder (Cast Pin Eye)

**Lift Cylinder**

Item	Part Number	Qty	Description of Part
1	1733233	1	Complete Lift Cylinder (Nordon)
2	1730839	1	Barrel – Lift Cylinder (Bale)
	1734220	1	Barrel – Lift Cylinder (Nordon)
3	1730840	1	Rod – Lift Cylinder (Bale)
	1734221	1	Rod – Lift Cylinder (Nordon)
4	1730841	1	Seal Kit – Lift/Tilt Cylinder (Bale) (Not Shown)
	1731355	1	Seal Kit – Lift/Tilt Cylinder (Nordon) (Not Shown)
5	1730634	1	Double Pilot Check Valve
6	1734156	1	Tube Lift Cylinder
7	1733343	2	Elbow M/M ¼ x 7/16
8	1733344	1	Straight Union Adaptor M/F ¼ x 7/16
9	1734248	3	Nipple M/M with Encapsulated Seal ¼ x 7/16

**Tilt Cylinder**

Item	Part Number	Qty	Description of Part
1	1733234	1	Complete Tilt Cylinder (Nordon)
2	1730845	1	Barrel – Tilt Cylinder (Bale)
	1734222	1	Barrel – Tilt Cylinder (Nordon)
3	1730846	1	Rod – Tilt Cylinder (Bale)
	1734223	1	Rod – Tilt Cylinder (Nordon)
4	1730841	1	Seal Kit – Lift/Tilt Cylinder (Bale) (Not Shown)
	1731355	1	Seal Kit – Lift/Tilt Cylinder (Nordon) (Not Shown)

5	1730634	1	Double Pilot Check Valve
6	1734155	1	Tube Tilt Cylinder
7	1733343	2	Elbow M/M ¼ x 7/16
8	1733344	1	Straight Union Adaptor M/F ¼ x 7/16
9	1734248	3	Nipple M/M with Encapsulated Seal ¼ x 7/16



**Bale Cylinder (Pin Eye Welded to Rod)**



**Nordon Cylinder (Cast Pin Eye)**

**Tele Cylinder**

Item	Part Number	Qty	Description of Part
1	1733235	1	Complete Tele Cylinder (Nordon)
2	1730842	1	Barrel – Tele Cylinder (Bale)
	1734224	1	Barrel – Tele Cylinder (Nordon)
3	1730843	1	Rod – Tele Cylinder (Bale)
	1734225	1	Rod – Tele Cylinder (Nordon)
4	4640438	1	Check Valve
5	1730844	1	Seal Kit – Tele Cylinder (Bale)
	1731356	1	Seal Kit – Tele Cylinder (Nordon)
6	1733345	2	Nipple M/M ¼ x 7/16

**This page left blank intentionally**

**LIGHT BAR ASSEMBLY**



Item	Part Number	Qty	Description of Part
1	1730574	1	Clipsal Junction Box with Lid CL156JBIGY
	1733288	1	Metal Junction Box Finished
2	1730746	5	Adaptor SP20-M20-M or 250-020_RFX
	1730862	5	Earth Tag Ring for Steel Conduit Swivel Fitting (Option)
3	1733740	1	Neutral Link, 5 Holes (Inside Junction Box)
4	1730487	2	Long Conduit Assembly (Prior to S/N 6308AN1784)
5	1730486	2	Short Conduit Assembly (Prior to S/N 6308AN 1784)
6	1734219	4	Light Conduit Assembly (S/N 6308AN1784 to Present)
7	1730250	1	Mast AC Harness Assembly



<b>Item</b>	<b>Part Number</b>	<b>Qty</b>	<b>Description of Part</b>
1	1730584	4	Metal Halide Lamp Assembly 1500W (6308AN)
	1730214	4	Metal Halide Lamp Assembly 2000W (8308AN)
2	1730585	4	Metal Halide Lamp Bulb 1500W (6308AN)
	1730216	4	Metal Halide Lamp Bulb 2000W (8308AN)
3	1734021	8	Ballast Capacitor Spare Set 1500W (6308AN)
	1001143828	8	Ballast Capacitor Spare Set 2000W (8308AN)
4	1730586	4	Complete Ballast Assembly 1500W (6308AN)
	1730215	4	Complete Ballast Assembly 2000W (8308AN)
5	1730921	4	Replacement Glass Lens
6	1734139	8	Light Assembly Gasket
7	1730362	4	Light Triunion
8	1734089	4	Light Mesh Guard (Option)
9	1730519	4	T-bar Bolt, Lamp Bracket Mount 3/4" x 4" UNC
10	1734230	4	Nut Retaining Bracket Finished
11	1732316	1	Nylatron Pad Strip 45mm Wide
12	1730759	2	Eye Bolt
13	1730758	4	Ring 75mm
14	1320224	5	Hose Clamp 5/8" Steel P Clip
15	1734030	4	Bottom Louvre
16	1734031	4	Top Louvre
17	1734032	4	L/H Reflector
18	1734033	4	R/H Reflector
19	1734034	4	Main Reflector
20	1734154	8	Hinge IP54
21	1734164	8	Latch Replacement Set IP54

**6308AN-6 & 9308AN LIGHT BAR ASSEMBLY**

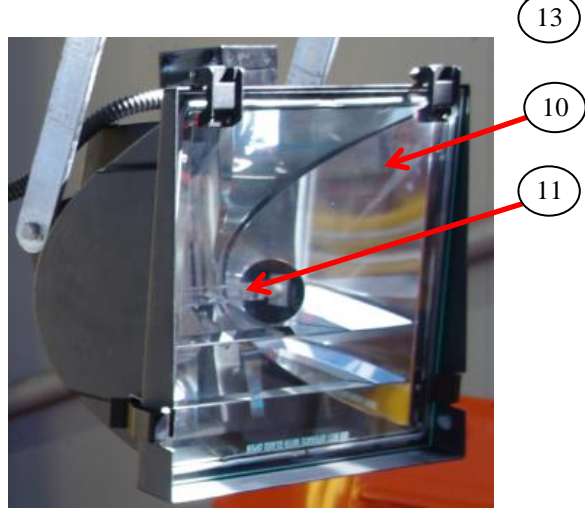
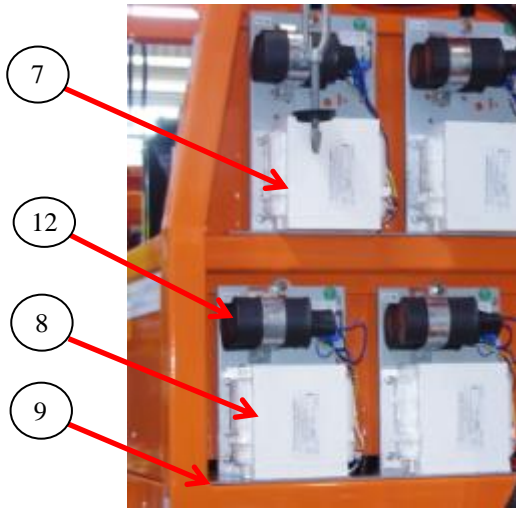
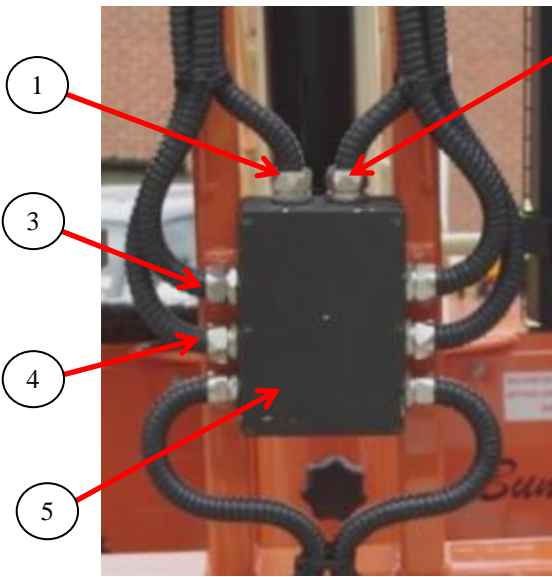

Item	Part Number	Qty	Description of Part
1	1733342	1	Mast AC Harness Assembly Lower
2	1730250	1	Mast AC Harness Assembly
3	1733341	2	Light Conduit Assembly (1.5m)
4	1734219	4	Light Conduit Assembly (1.1m)
5	1731325	1	6 Lights Junction Box Finished
6	1734405	2	6 Lights LT Top Trunion Bracket
7	1001163047	6	1000W HPS Lamb Ballast Assembly (6308AN-6 HPS)
	1730994	4	1000W Metal Halide Lamp Ballast Assembly (6308AN-6)
	1730586	4	1500W Lamp Ballast Assembly (9308AN)
8	1733386	2	1000W Metal Halide Lower Lamp Ballast Assembly (6308AN-6)
	1731333	2	1500W Metal Halide Lower Lamp Ballast Assembly (9308AN)
9	1731331	1	Nylatron Pad Strip 45mm Wide Short
10	1001161926	6	1000W HPS Light Housing (6308AN-6 HPS)
	1730993	6	1000W Metal Halide Light Assembly (6308AN-6)
	1730584	6	1500W Metal Halide Light Assembly (9308AN)
11	1001175210	6	1000W HPS Lamp Bulb c/w Ignitor (6308AN-6 HPS)
	1730995	6	1000W Metal Halide Lamp Bulb (6308AN-6)
	1730585	6	1500W Metal Halide Lamp Bulb (9308AN)
12	1001143828	6	1000W HPS Ballast Capacitor (6308AN-6 HPS)
	1730937	6	1000W Metal Halide Ballast Capacitor (6308AN-6)
	1734021	12	1500W Metal Halide Ballast Capacitor (9308AN)
13	0682236	2	¾"UNC x 4 ½" Grade 8 Bolt

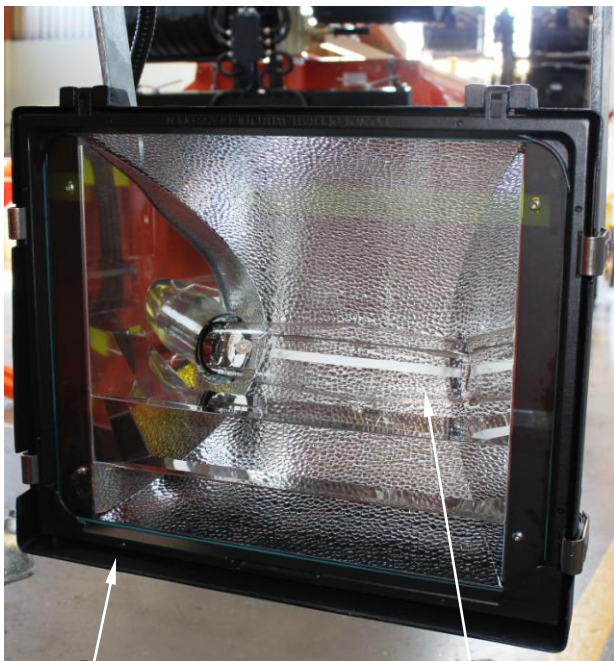

10

1001161926

11

1001175210



12

1001143828

07

1001163047

**OTHER CHASSIS COMPONENTS**

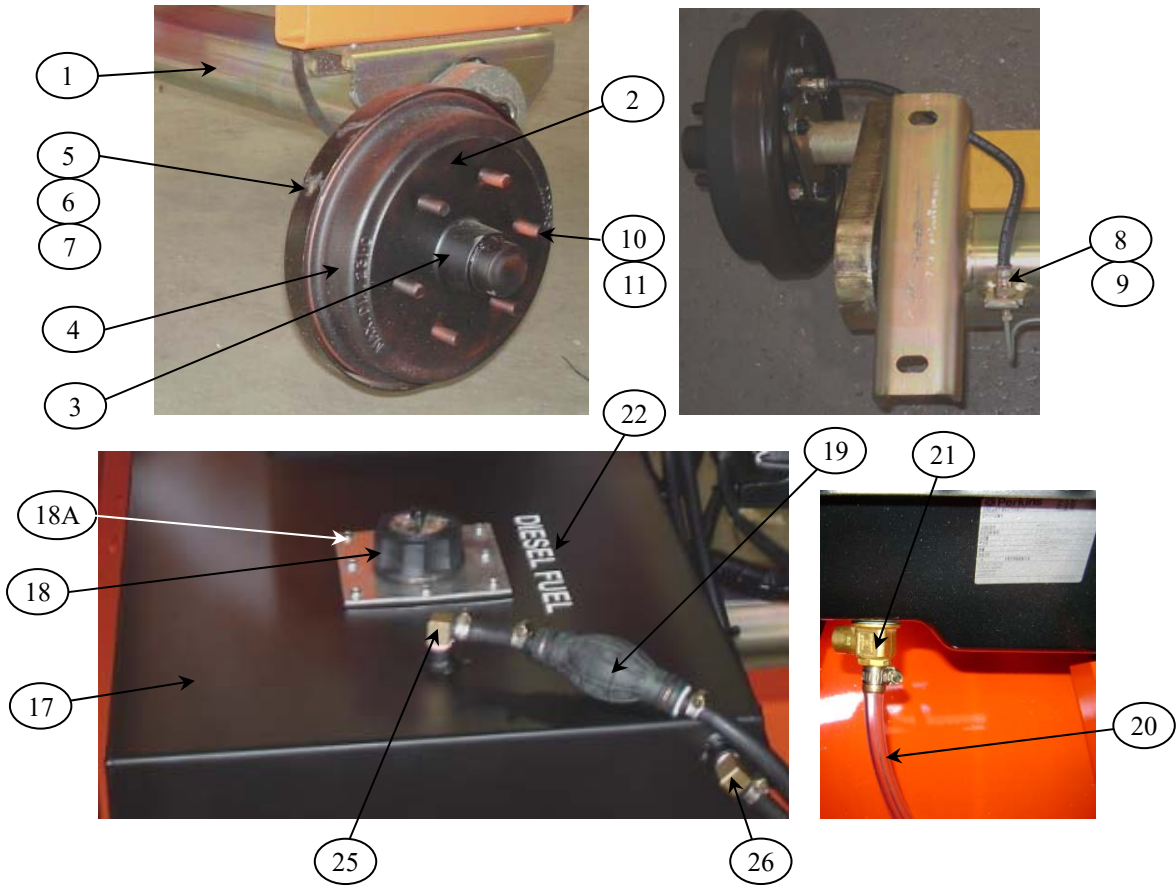

Item	Part Number	Qty	Description of Part
1	1730891	1	Axle Assembly 1650kg C/W Brakes (Alko)
	1730573	1	Axle Assembly 1900kg C/W Brakes (Vehicle Components)
2	1730825	2	Brake Drum Hub (superseded by 1001249150)
	1001249150		Brake, 9SL H/Drum (C/W hub bearings)
3	1730915	2	Wheel Bearing Set (Seal, Dust Cap and Split Pin)
4	1730577	2	Brake Shoe Set
5	1734097	2	Backing Plate RH (Vehicle Components)
6	1730883	2	Backing Plate LH (Vehicle Components)
7	1734486	2	Backing Plate Pair (Alko)
8	1730884	2	Bleed Nipple
9	1730882	2	Brake Wheel Cylinder (9" Drum)
10	1730885	12	Wheel Stud
11	1730886	12	Wheel Nut
12	1730887	2	Dust Cap
13	1730888	2	3/4" UNF Nut Bearing Retainer
14	1730889	2	3/4" Washer
15	1730890	2	3.2 x 32 Split Pin
16	1730920	2	Wheel Bearing Seal
17	1733282	1	Fuel Tank Finished
18	1730898	1	Fuel Gauge and Cap
18A	1733318	A/R	Filler Neck (to suit Fuel Tank 1730759)
	3911010	8	Round Head Screws 10-24 x 5/8"
	1733510	A/R	Gasket, Filler Neck Rubber
19	1730815	1	Fuel Line Primer Bulb Pump

20	1733314	1	Tube, Engine Oil Drain	
21	4641272	1	Valve, Oil Drain	
22	1700200	1	Decal 'Diesel Fuel'	
23	1320043	2	Hose Clamp 1/4" Steel P Clip	
24	1320061	5	Hose Clamp 3/4" Steel P Clip	
25	1730939	1	Brass Hosetail 1/4 BSPT x 1/4 Hose	
26	1730940	1	Brass Hosetail 1/4 BSPT x 3/8 Hose	
27	1730766	1	Brake-Line Kit (for Axle 1730891)	} Included in the brake-line kit
	1733808	1	Long Tube Draw Bar	
	1733809	1	Short Tube (Left)	
	1733810	1	Short Tube (Right)	
	1733811	1	Tee-Connector	
	1733812	1	Flexible Hose Drawbar	
	1733813	2	Flexible Hose Side (320 mm long)	
	1733814	3	'C' Clips	
	1001244947	A/R	Flexible Hose Side (420 mm long) in lieu of Hose 1733813	
28	1001148979	1	Brake-Line Kit (for Axle 1730573)	} Included in the brake-line kit
	1001148976	1	Tube, Brake Line LH, VC Bunded	
	1001148977	1	Tube, Brake Line RH, VC Bunded	
	1001148978	2	Hose Assembly, Brake Line, VC Bunded	
	1733811	1	Tee-Connector (6308AN Brake Tube)	
	1733812	1	Hose Assembly, Drawbar (6308AN)	
	1733814	3	C-Clips (6308AN brake hose)	



AL-KO axle 1730891



Vehicle Components Axle 1730573

**RADIATOR OVERFLOW BOTTLE AND MANUALS HOLDER**

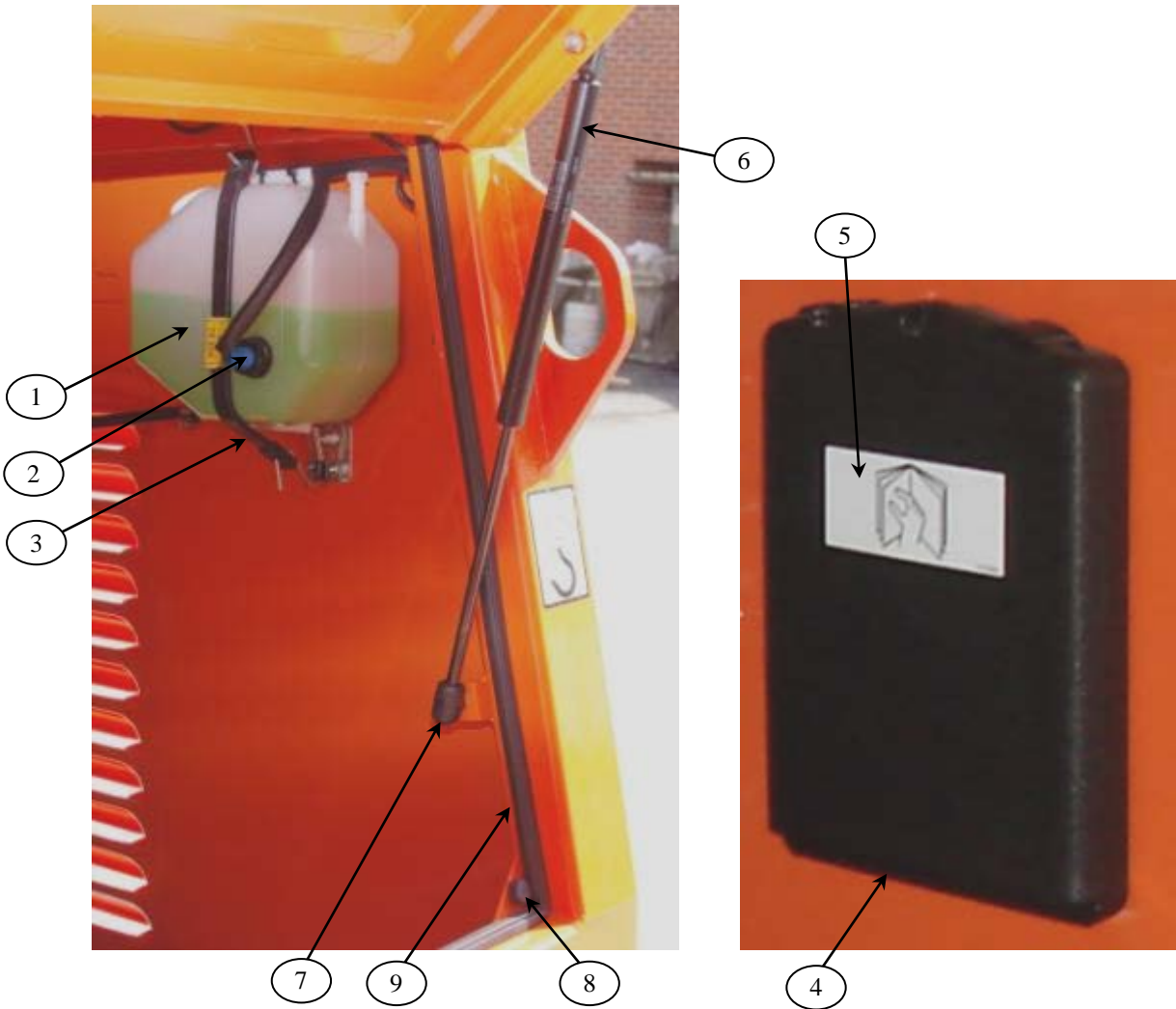

Item	Part Number	Qty	Description of Part
1	1730785	1	Overflow Bottle
2	1730918	1	Water Level Sensor
	1730919	1	Kit. Water Level Sensor Replacement (Converts Early Sensor Probe to Later Float Level Switch)
3	1730791	1	Rubber Strap
4	0860520	1	Box Manual Storage
5	1701509	1	Decal – Manual Storage Box
6	A330435	2	Gas Strut Door
7	A330437	2	Ball Stud for Gas Spring
8	0940036	5	Door Bumper Rubber
9	1734188	5	Door Rubber Seal

# SECTION FOUR

## RECOMMENDED SPARES QUICK REFERENCE

ITEM DESCRIPTION	PART NO
Solenoid Pump Motor	1730549
Pushbutton Switch Pump	4360387
Main Breaker RCD	1730621
Switch Circuit breaker 10 A Single Pole	1730622
Switch Circuit Breaker 10 A Double Pole	1730197
Lamp Warning Green	2920027
Lamp Warning Red	2920026
Keyswitch Engine W/Key	1730540
Fan Belt (Kubota)	1730870
Fan Belt (Perkins)	1734153
Hose Radiator Top (Kubota)	1730867
Hose Radiator Top (Perkins)	1734422
Hose Radiator Lower (Kubota)	1730868
Hose Radiator Lower (Perkins)	1734423
Air Filter Element (Kubota)	1730565
Air Filter Element (Perkins)	1734415
Fuel Filter (Kubota)	1730873
Fuel Filter (Perkins)	1733164
Oil Filter (Kubota)	1730569
Oil Filter (Perkins)	1733165
Lamp Metal Halide 1500 W	1730585
Lamp HPS 1000 W c/w Ignitor Bulb	1001175210
Warning Lamp Bulb 12 V	2920029
Switch Circuit Breaker 15 A DC	4360070
Switch Circuit Breaker 20 A DC	4360161

## New Product Warranty

**1. WARRANTY.** JLG Industries (Australia), ("Manufacturer") warrants each new Lighting Tower product made by it to be free from defects in material or workmanship for TWELVE months from the date of initial sale of such product. Manufacturer agrees only to repair or replace at its own expense, F.O.B. the place or places of manufacture, any part or parts of the product found to be defective in material or workmanship, provided Manufacturer is notified of such defect or defects within the applicable warranty period and given a reasonable time to correct the defect. In no case shall any warranty extend to defects in materials, components, or services furnished by third parties. Defects caused by chemical action or the presence of abrasive materials and defects arising through the improper use or application of this Light Tower shall not be considered defects within the scope of the above mentioned warranty. If any repairs or alterations are made or any parts are replaced during the periods covered by any warranty above mentioned by other than an authorised Manufacturer's Distributor or authorised Service Agent in accordance with authorised Manufacturer's service manuals or with other than parts, accessories, or attachments authorised by Manufacturer for use in its products, customer shall pay for such repairs or parts without recourse against Manufacturer, and Manufacturer shall be relieved of responsibility for fulfilment of the above mentioned warranty with respect to parts or components for all repairs, alterations, or replacements so made. Manufacturer's obligations under this warranty shall at all times be subject to its then current warranty policies and procedures. The above mentioned warranty shall not apply to replacement or service parts made by and sold by the Manufacturer, with any obligation of the Manufacturer to such parts governed solely by Manufacturer's then current warranty policies and procedures.

**2. DISCLAIMER AS TO CONSEQUENTIAL OR SPECIAL DAMAGES.** Under no circumstances shall the Manufacturer be liable for any consequential or special damages which any person, firm, corporation, or other entity may suffer or claim to suffer or incur or claim to incur as a result of any defect in the product or in any correction or alteration thereof made or furnished by Manufacturer or others. "Consequential" or "special damages" as used herein includes but is not limited to costs of transportation, lost sales, lost orders, lost profits, lost income, loss of hire, increased overhead, labour and material costs, and costs of manufacturing variances and operational inefficiencies.

**3. MAXIMUM LIABILITY.** The maximum liability of Manufacturer under the exclusive warranty set forth herein shall be the amount paid to Manufacturer with respect to the product to which such warranty applies.

**4. EXCLUSIVE AND ENTIRE WARRANTY.** This warranty constitutes Manufacturer's entire warranty as to the product and it is agreed that the remedies of customer and those claiming under customer as stated in this warranty are exclusive. Manufacturer does not assume (and has not authorised any other person to assume on its behalf) any other warranty or liability in connection with any product covered by this warranty. MANUFACTURER EXPRESSLY DISCLAIMS ANY AND ALL OTHER WARRANTIES OF ANY KIND WHATSOEVER AS TO THE PRODUCT FURNISHED HEREUNDER, INCLUDING BUT NOT LIMITED TO EXPRESS OR IMPLIED WARRANTIES AS TO MERCHANTABILITY, FITNESS FOR PARTICULAR PURPOSES SOLD, DESCRIPTION OR QUALITY OF THE PRODUCT FURNISHED HEREUNDER.

**5. NOTICE OF OCCURRENCE.** This warranty shall be void if, upon the occurrence of any incident involving any product made by Manufacturer and resulting in any personal injury or property damage, customer shall fail to notify Manufacturer within 48 hours of such occurrence or permit Manufacturer and its representatives to have immediate access to such product and to all records of or within the control of customer relating to the product and occurrence.

**6. LIMITATION OF LIABILITY.** The limitation of liability provisions herein shall apply to any and all claims or suits brought against Manufacturer including any claim based upon negligence, breach of contract, breach of warranty, strict liability, or any other legal theories upon which liability may be asserted against Manufacturer.

Manufacturer may at any time amend the foregoing form of warranty without prior notice.