

Atlas Copco Portable air compressors

XAS 46-76

43 to 68 l/s (91 to 145 cu.ft/min) - 7 bar (102 psig)

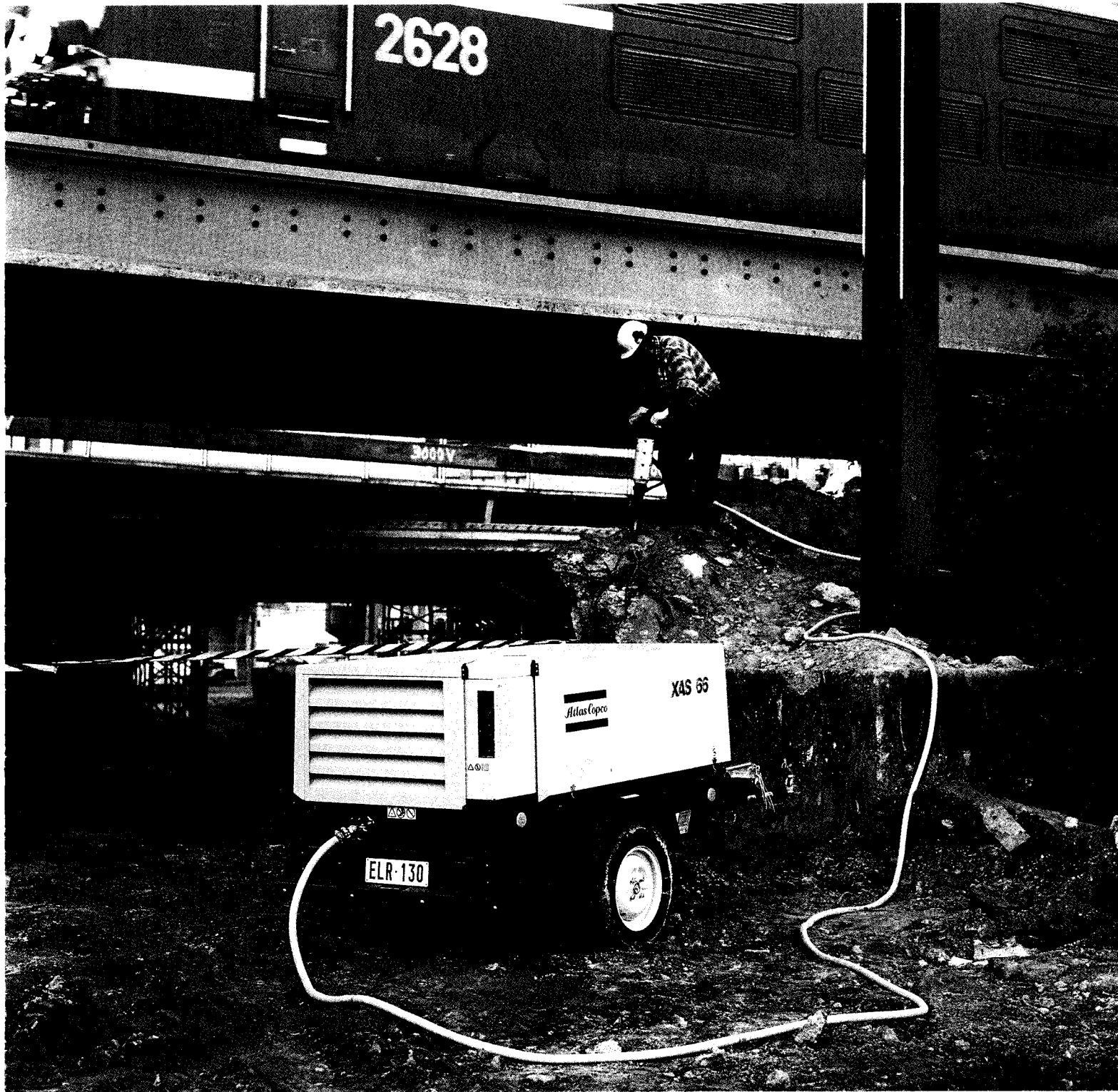

Atlas Copco

Series 6

A completely new concept in portable air compressors

Series 6 - XAS46, XAS56, XAS66, XAS76 - is an innovative range of oil injected, rotary screw compressors. These single axle compressors are powered by a new Deutz diesel engine (2 or 3 cylinders) to provide reliable compressed air for pneumatic tools such as chipping hammers, jackhammers, nut runners, grinding tools, and rammers - or for sandblasting. An optional generator provides added power for fusion welding, light poles, heating of cabins, instrumentation and electric power tools.

The features you 've always wanted

For the Series 6, Atlas Copco involved end users and sales companies in the design from the very beginning. This attention to your needs resulted in the development of many new features, including a new compressor element, a new diesel engine, a unique canopy and a modular concept that allows you to add many options to suit your needs.

Meets legal safety and environmental requirements

The Series 6 compressors meet current and pending European Community legal requirements for the working environment; and regulations for safety, exhaust emissions, and noise.

Built and tested to ISO 9001 quality assurance standards

Atlas Copco's stringent manufacturing standards - which follow the ISO 9001 regulations for quality assurance - produce compressors that are made and tested to perform in the most demand-ing conditions.

Atlas Copco - the world leader in portable air compressors

Atlas Copco supplies one out of every three portable air compressors in the world. This remarkable sales record is the result of years of technological leadership in compressed air. We strive to fulfill your highest expectations in quality, performance, reliability and service.

With our advanced research and development, the world's largest dedicated compressor manufacturing plant, and proven applications around the world, Atlas Copco is the complete answer to all your compressed air needs.

You'll find Atlas Copco representatives nearby who are ready to help you. Our extensive global service and dealer network provides local customer support around the world for sales, training and service.

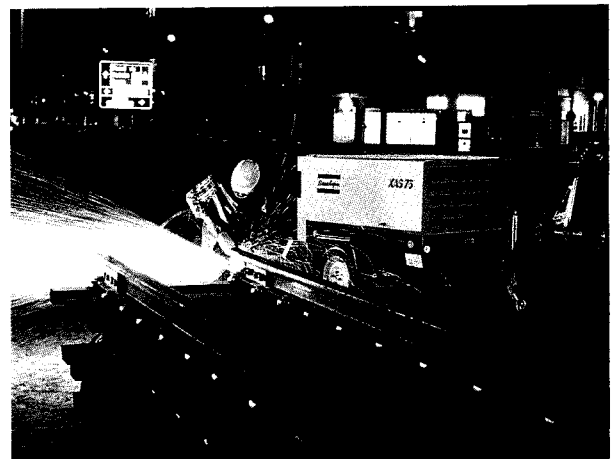

The low decibel rating makes the Series 6 perfect for quiet operation near hospitals and schools, in residential areas, and even at night.

Series 6

Everything you

The single, high performance, two-stage air intake filter prevents dust and dirt particles from entering the engine and the compressor. A service indicator on the filter tells you when it needs replacement or maintenance.

All the controls are grouped on a single panel near the outlet valves, and covered by a plastic cover for easy monitoring, safety and foolproof operation.

Low rotor speed, and few moving parts. The efficient engineering design of the compressor helps minimize wear, ensuring reliability second to none and a long working life.

You can easily remove the undercarriage for permanent mounting on a lorry.

A timing belt drive has been chosen over a fixed coupling for better longevity and no repairs.

A high capacity fuel tank carries you through a full shift and assures maximum productivity.

A fully automatic stepless speed regulator constantly adapts the engine speed to the air demand. You can count on economical power consumption, low fuel consumption, and continuous air flow at stable pressure.

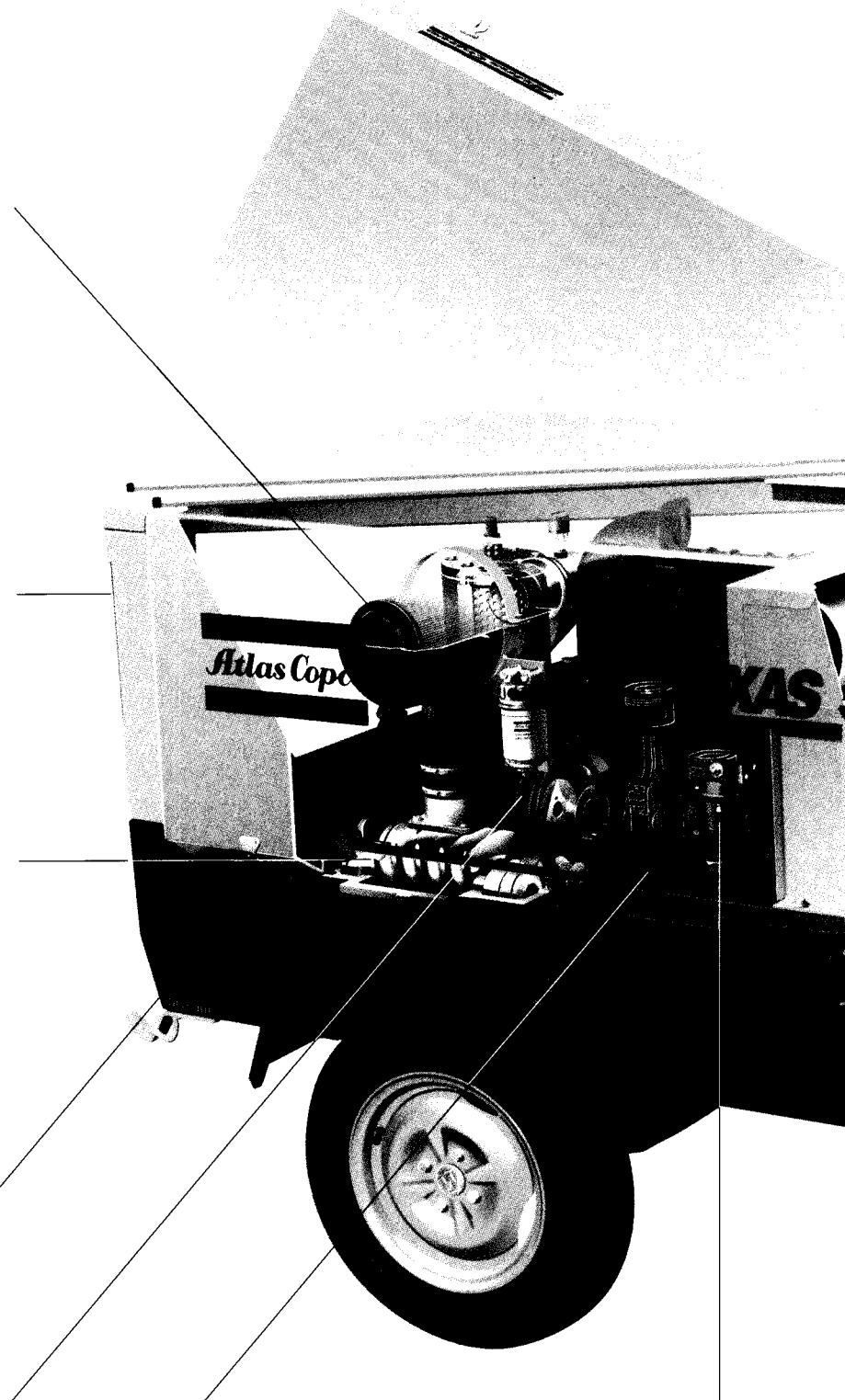

asked for in compressed air power

The canopy doors open diagonally with the help of pneumatic springs to give you easy access to the machinery. With the doors up and out of the way, you can perform routine maintenance in less time.

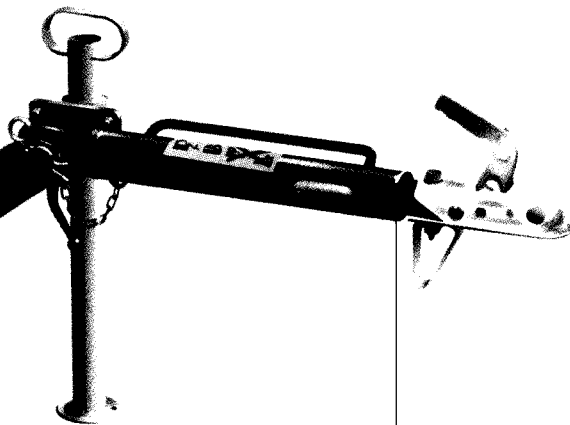
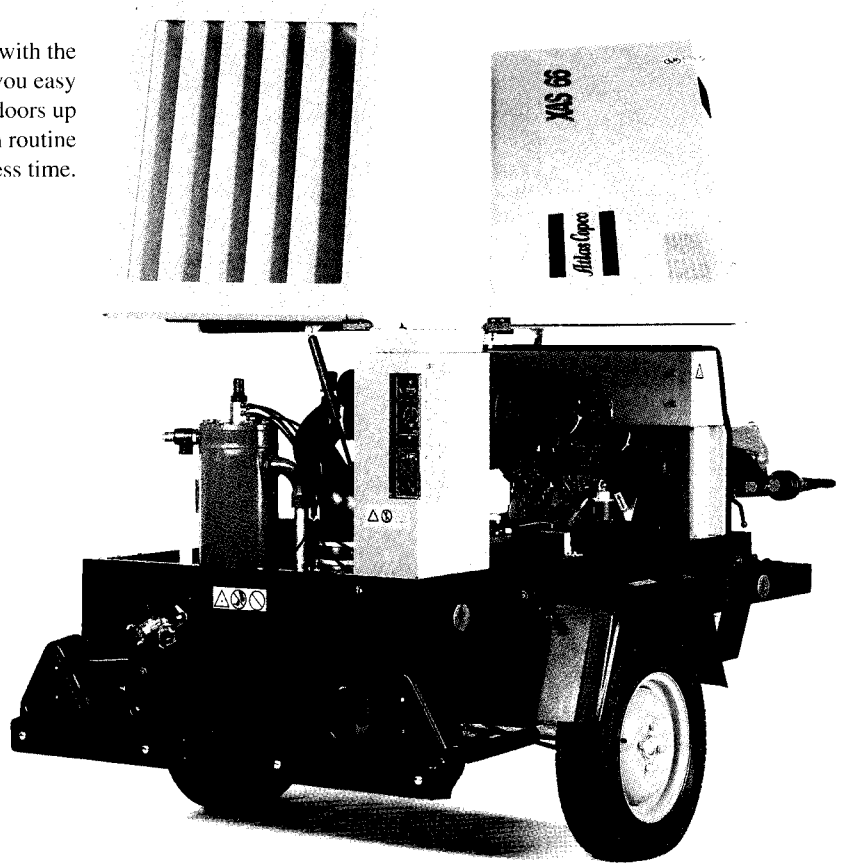
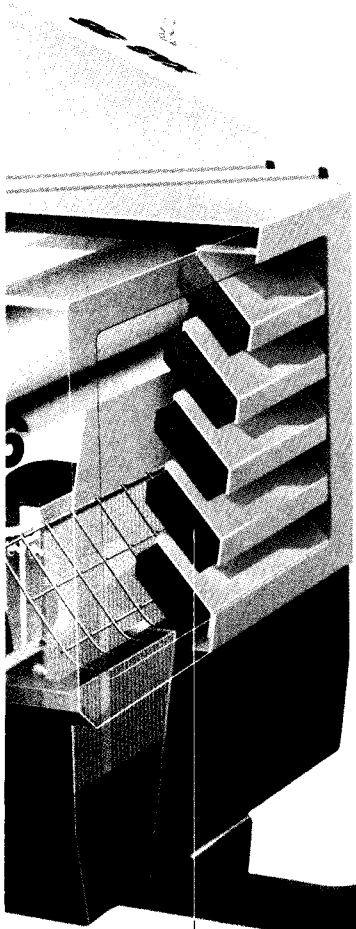

Efficient noise dampening

All units comply fully with the legal requirements for noise regulations.

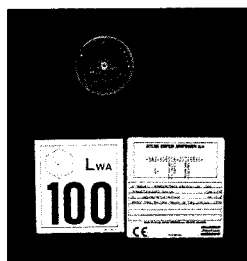

The XAS46 and -56 are so light, they don't need brakes when being towed.

Series 6 Principal data

Compressor

Type		XAS46	XAS46 DdG	XAS56	XAS66	XAS66 DdG	XAS76
Normal effective working pressure	bar	7	7	7	7	7	7
	psig	102	102	102	102	102	102
Actual free air delivery guaranteed according to ISO1217	l/s	43	33	50	61	56	68
	m ³ /min	2.6	2	3	3.7	3.4	4.1
ed.3 1996 annex D	cu.ft/min	91	70	106	130	120	145
Sound power: acc. 84/533 and 85/406 EEC	dB(A)	100	100	100	100	100	100
Sound pressure level acc. ISO2151 from 7m	dB(A)	72	72	72	72	72	72
Oil capacity	l	6.5	6.5	6.5	6.5	6.5	6.5
	gal	1.7	1.7	1.7	1.7	1.7	1.7

Generator

			50 Hz				50 Hz			
			110V ¹⁾		230/400V ²⁾		110V ¹⁾		230/400V ²⁾	
Electric power	1 ph	kW/kVA	–	4.4/4.4	4/4	–	–	4.4/4.4	4/4	–
	3 ph	kW/kVA	–	–	5.2/6.5	–	–	–	5.2/6.5	–
Sockets	CEE 1 ph	A	–	2x16+1x32	–	–	–	2x16+1x32	–	–
	CEE 3 ph	A	–	–	1 x 16	–	–	–	1 x 16	–
	Schuko 1 ph	A	–	–	2 x 16	–	–	–	2 x 16	–

¹⁾ complying with British Gas Spec. TIN 12

²⁾ complying with ISO 8528/8 - DIN 6280/10

Engine

Type - model	Deutz	F2M1011	F2M1011	F2M1011	F3M1011F	F3M1011F	F3M1011F	F3M1011F
Number of cylinders		2	2	2	3	3	3	3
Full load speed	r/min	2600	3000	3000	2400	2700	2700	2700
Output at rated speed	kW	20.4	22.5	22.5	30.3	33.2	33.2	33.2
Capacity of fuel tank	l	40	40	40	58	58	58	58
	gal	10.6	10.6	10.6	15.3	15.3	15.3	15.3

Unit dimensions

		XAS 46-56				XAS 66-76			
		without brakes		with brakes		without brakes		with brakes	
	towbar :	fixed	adjustable	fixed	adjustable	fixed	adjustable	fixed	adjustable
Length	mm	2837	3256	2915	3334	2987	3406	3065	3484
	inch	112	128	115	131	118	134	121	137
Width	mm	1300	1300	1300	1300	1350	1350	1350	1350
	inch	51	51	51	51	53	53	53	53
Height	mm	1273	1273	1273	1273	1273	1273	1273	1273
	inch	50	50	50	50	50	50	50	50
Weight (ready-to-operate)*	kg	702	712	731	748	787	797	819	835
	inch	1548	1570	1612	1649	1735	1757	1799	1841

* 110V: +35 kg /77 lbs – 230/400V: +42kg / 93 lbs

ATLAS COPCO COMPRESSORS AUSTRALIA
a division of
ATLAS COPCO AUSTRALIA P/L
A.C.N. 000 086 706

Atlas Copco

Never use compressed air as breathing air without prior purification in accordance with local legislation and standards.

Visit our website: www.atlascopco.com



Air Compressor 130 CFM

plant No's. 0101 009

010, 011, 012, 015

Instruction Manual and Parts List 016
for Portable Compressors

XAS66 Dd

	<u>PAGE</u>
Instruction manual.....	3
Instructieboek.....	35
Manuel d'instructions.....	67
Bedienungsanleitung.....	99
Libro de instrucciones.....	131
Instruktionsmanual.....	163
Istruzioni per l'uso.....	195
Bruksanvisning.....	227
Instruktionsbog.....	259
Εγχειρίδιο οδηγιών.....	291
Manual de instruções.....	323
Ohjekirja.....	355
Parts list - Onderdelenlijst - Liste de pièces - Ersatzteilliste - Lista de las partes - Reservdelsförteckning - Listino parti di ricambio - Deleliste - Reservedelsliste - Κατάλογος Εξαρτημάτων - Lista de peças - Osaluettelo.....	387
Glossary - Woordenlijst - Glossaire - Glossar - Glosario - Ordlista - Glossario - Ordliste - Ordliste - Γλωσσάριο - Glossário - Sanasto.....	491

Registration code
Collecton: X1
Tab: 38

Printed matter N°
2950 0212 04

2001 - 02



Congratulations on the purchase of your Atlas Copco compressor. It is a solid, safe and reliable machine, built according to the latest technology. Follow the instructions in this booklet and we guarantee you years of troublefree operation. Please read the following instructions carefully before starting to use your machine.

Always keep the manual available near the machine.

In all correspondence always mention the compressor type and serial number, shown on the data plate.

The company reserves the right to make changes without prior notice.

CALIFORNIA

Proposition 65 Warning

Diesel engine exhaust and some of its constituents are known to the State of California to cause cancer, birth defects, and other reproductive harm.

CONTENTS	PAGE
1 Safety precautions for portable compressors	5
1.1 Introduction	5
1.2 General safety precautions	5
1.3 Safety during transport and installation	6
1.4 Safety during use and operation	6
1.5 Safety during maintenance and repair	7
1.6 Tool applications safety	8
1.7 Specific safety precautions	8
2 Leading particulars	9
2.1 Description of safety pictograms used in this manual	9
2.2 General description	9
2.3 Markings and information labels	10
2.4 Main Parts	11
2.5 Air flow	12
2.6 Oil system	13
2.7 Continuous regulating system	13
2.8 Electrical system	14
2.8.1 Circuit diagram	14
2.8.2 Description	15
3 Operating instructions	16
3.1 Parking, towing and lifting instructions	16
3.1.1 Parking instructions	16
3.1.2 Towing instructions	16
3.1.3 Height adjustment (with adjustable towbar)	17
3.1.4 Lifting instructions	17
3.2 Before starting	17
3.3 Starting/Stopping	18
3.4 During operation	18

CONTENTS	PAGE	CONTENTS	PAGE
4 Maintenance	19	6 Problem solving	27
4.1 Use of service paks	19	6.1 Alternator precautions.....	27
4.2 Preventive maintenance schedule for the compressor	19	7 Available options	30
4.3 Lubrication oils	20	8 Installation recommendations for frame support	31
4.4 Oil level check	20	9 Technical specifications	33
4.4.1 Check engine oil level.....	20	9.1 Torque values.....	33
4.4.2 Check compressor oil level.....	20	9.1.1 For general applications.....	33
4.5 Oil and oil filter change	21	9.1.2 For important assemblies.....	33
4.5.1 Engine oil and oil filter change.....	21	9.2 Settings of shutdown switches and safety valves	33
4.5.2 Compressor oil and oil filter change.....	21	9.3 Compressor/engine specifications	33
4.6 Cleaning coolers	21	9.4 Conversion list of SI units into British units.....	34
4.7 Battery care	22	10 Data plate	34
4.7.1 Electrolyte.....	22		
4.7.2 Activating a dry-charged battery	22		
4.7.3 Recharging a battery	22		
4.7.4 Battery maintenance	22		
4.8 Storage	22		
4.9 Service paks	22		
4.10 Service kits.....	22		
4.11 Compressor element overhaul	22		
4.12 Liability.....	22		
5 Adjustments and servicing procedures	23		
5.1 Adjustment of the continuous regulating system	23		
5.2 Air filter engine/compressor	24		
5.2.1 Main parts	24		
5.2.2 Recommendations.....	24		
5.2.3 Cleaning the dust trap	24		
5.2.4 Replacing the air filter element.....	24		
5.3 Air receiver	24		
5.4 Safety valve.....	24		
5.5 Fuel system	25		
5.6 Brake (= option) adjustment	25		
5.6.1 Brake shoe adjustment	25		
5.6.2 Test procedure of brake cable adjustment	26		
5.6.3 Brake cable adjustment	26		
5.7 Drive Belt.....	26		

1. SAFETY PRECAUTIONS FOR PORTABLE COMPRESSORS

To be read attentively and acted accordingly before towing, lifting, operating, performing maintenance or repairing the compressor

1.1 INTRODUCTION

The policy of Atlas Copco is to provide the users of their equipment with safe, reliable and efficient products. Factors taken into account are among others:

- the intended and predictable future use of the products, and the environments in which they are expected to operate,
- applicable rules, codes and regulations,
- the expected useful product life, assuming proper service and maintenance,
- providing the manual with up-to-date information.

Before handling any product, take time to read the relevant instruction manual. Besides giving detailed operating instructions, it also gives specific information about safety, preventive maintenance, etc.

Keep the manual always at the unit location, easy accessible to the operating personnel.

See also the safety precautions of the engine and possible other equipment, which are separately sent along or are mentioned on the equipment or parts of the unit.

These safety precautions are general and some statements will therefore not always apply to a particular unit.

Only people that have the right skills should be allowed to operate, adjust, perform maintenance or repair on Atlas Copco equipment. It is the responsibility of management to appoint operators with the appropriate training and skill for each category of job.

Skill level 1: Operator

An operator is trained in all aspects of operating the unit with the push-buttons, and is trained to know the safety aspects.

Skill level 2: Mechanical technician

A mechanical technician is trained to operate the unit the same as the operator. In addition, the mechanical technician is also trained to perform maintenance and repair, as described in the instruction manual, and is allowed to change settings of the control and safety system. A mechanical technician does not work on live electrical components.

Skill level 3: Electrical technician

An electrical technician is trained and has the same qualifications as both the operator and the mechanical technician. In addition, the electrical technician may carry out electrical repairs within the various enclosures of the unit. This includes work on live electrical components.

Skill level 4: Specialist from the manufacturer

This is a skilled specialist sent by the manufacturer or its agent to perform complex repairs or modifications to the equipment.

In general it is recommended that not more than two people operate the unit, more operators could lead to unsafe operating conditions. Take necessary steps to keep unauthorized persons away from the unit and eliminate all possible sources of danger at the unit.

When handling, operating, overhauling and/or performing maintenance or repair on Atlas Copco equipment, the mechanics are expected to use safe engineering practices and to observe all relevant local safety requirements and ordinances. The following list is a reminder of special safety directives and precautions mainly applicable to Atlas Copco equipment.

These safety precautions apply to machinery processing or consuming air. Processing of any other gas requires additional safety precautions typical to the application and are not included herein.

Neglecting the safety precautions may endanger people as well as environment and machinery:

- endanger people due to electrical, mechanical or chemical influences,
- endanger the environment due to leakage of oil, solvents or other substances,
- endanger the machinery due to function failures.

All responsibility for any damage or injury resulting from neglecting these precautions or by non-observance of ordinary caution and due care required in handling, operating, maintenance or repair, also if not expressly mentioned in this instruction manual, is disclaimed by Atlas Copco.

The manufacturer does not accept any liability for any damage arising from the use of non-original parts and for modifications, additions or conversions made without the manufacturer's approval in writing.

If any statement in this manual does not comply with local legislation, the stricter of the two shall be applied.

Statements in these safety precautions should not be interpreted as suggestions, recommendations or inducements that it should be used in violation of any applicable laws or regulations.

1.2 GENERAL SAFETY PRECAUTIONS

- 1 The owner is responsible for maintaining the unit in a safe operating condition. Unit parts and accessories must be replaced if missing or unsuitable for safe operation.
- 2 The supervisor, or the responsible person, shall at all times make sure that all instructions regarding machinery and equipment operation and maintenance are strictly followed and that the machines with all accessories and safety devices, as well as the consuming devices, are in good repair, free of abnormal wear or abuse, and are not tampered with.
- 3 Whenever there is an indication or any suspicion that an internal part of a machine is overheated, the machine shall be stopped but no inspection covers shall be opened before sufficient cooling time has elapsed, this to avoid the risk of spontaneous ignition of oil vapour when air is admitted.
- 4 Normal ratings (pressures, temperatures, speeds, etc.) shall be durably marked.
- 5 Operate the unit only for the intended purpose and within its rated limits (pressure, temperature, speeds, etc.).
- 6 The machinery and equipment shall be kept clean, i.e. as free as possible from oil, dust or other deposits.
- 7 To prevent an increase in working temperature, inspect and clean heat transfer surfaces (cooler fins, intercoolers, water jackets, etc.) regularly. See the maintenance schedule.
- 8 All regulating and safety devices shall be maintained with due care to ensure that they function properly. They may not be put out of action.
- 9 Care shall be taken to avoid damage to safety valves and other pressure-relief devices, especially to avoid plugging by paint, oil coke or dirt accumulation, which could interfere with the functioning of the device.
- 10 Pressure and temperature gauges shall be checked regularly with regard to their accuracy. They shall be replaced whenever outside acceptable tolerances.
- 11 Safety devices shall be tested as described in the maintenance schedule of the instruction manual to determine that they are in good operating condition.
- 12 Mind the markings and information labels on the unit.
- 13 In the event the safety labels are damaged or destroyed, they must be replaced to ensure operator safety.
- 14 Keep the work area neat. Lack of order will increase the risk of accidents.
- 15 When working on the unit, wear safety clothing. Depending on the kind of activities these are: safety glasses, ear protection, safety helmet (including visor), safety gloves, protective clothing, safety shoes. Do not wear the hair long and loose (protect long hair with a hairnet), or wear loose clothing or jewelry.
- 16 Take precautions against fire. Handle fuel, oil and anti-freeze with care because they are inflammable substances. Do not smoke or approach with naked flame when handling such substances. Keep a fire-extinguisher in the vicinity.

1.3 SAFETY DURING TRANSPORT AND INSTALLATION

To lift a unit, all loose or pivoting parts, e.g. doors and towbar, shall first be securely fastened.

Do not attach cables, chains or ropes directly to the lifting eye; apply a crane hook or lifting shackle meeting local safety regulations. Never allow sharp bends in lifting cables, chains or ropes.

Helicopter lifting is not allowed.

It is strictly forbidden to dwell or stay in the risk zone under a lifted load. Never lift the unit over people or residential areas. Lifting acceleration and retardation shall be kept within safe limits.

- 1 Before towing the unit:
 - ascertain that the pressure vessel(s) is (are) depressurized,
 - check the towbar, the brake system and the towing eye. Also check the coupling of the towing vehicle,
 - check the towing and brake capability of the towing vehicle,
 - check that the towbar, jockey wheel or stand leg is safely locked in the raised position,
 - ascertain that the towing eye can swivel freely on the hook,
 - check that the wheels are secure and that the tyres are in good condition and inflated correctly,
 - connect the signalisation cable, check all lights and connect the pneumatic brake couplers,
 - attach the safety break-away cable or safety chain to the towing vehicle,
 - remove wheel chocks, if applied, and disengage the parking brake.
- 2 To tow a unit use a towing vehicle of ample capacity. Refer to the documentation of the towing vehicle.
- 3 If the unit is to be backed up by the towing vehicle, disengage the overrun brake mechanism (if it is not an automatic mechanism).
- 4 Never exceed the maximum towing speed of the unit (mind the local regulations).
- 5 Place the unit on level ground and apply the parking brake before disconnecting the unit from the towing vehicle. Unclip the safety break-away cable or safety chain. If the unit has no parking brake or jockey wheel, immobilize the unit by placing chocks in front of and/or behind the wheels. When the towbar can be positioned vertically, the locking device must be applied and kept in good order.
- 6 To lift heavy parts, a hoist of ample capacity, tested and approved according to local safety regulations, shall be used.
- 7 Lifting hooks, eyes, shackles, etc., shall never be bent and shall only have stress in line with their design load axis. The capacity of a lifting device diminishes when the lifting force is applied at an angle to its load axis.
- 8 For maximum safety and efficiency of the lifting apparatus all lifting members shall be applied as near to perpendicular as possible. If required, a lifting beam shall be applied between hoist and load.
- 9 Never leave a load hanging on a hoist.
- 10 A hoist has to be installed in such a way that the object will be lifted perpendicular. If that is not possible, the necessary precautions must be taken to prevent load-swinging, e.g. by using two hoists, each at approximately the same angle not exceeding 30° from the vertical.
- 11 Locate the unit away from walls. Take all precautions to ensure that hot air exhausted from the engine and driven machine cooling systems cannot be recirculated. If such hot air is taken in by the engine or driven machine cooling fan, this may cause overheating of the unit; if taken in for combustion, the engine power will be reduced.

1.4 SAFETY DURING USE AND OPERATION

- 1 When the unit has to operate in a fire-hazardous environment, each engine exhaust has to be provided with a spark arrestor to trap incendiary sparks.
- 2 The exhaust contains carbon monoxide which is a lethal gas. When the unit is used in a confined space, conduct the engine exhaust to the outside atmosphere by a pipe of sufficient diameter; do this in such a way that no extra back pressure is created for the engine. If necessary, install an extractor. Observe any existing local regulations. Make sure that the unit has sufficient air intake for operation. If necessary, install extra air intake ducts.
- 3 When operating in a dust-laden atmosphere, place the unit so that dust is not carried towards it by the wind. Operation in clean surroundings considerably extends the intervals for cleaning the air intake filters and the cores of the coolers.
- 4 Close the compressor air outlet valve before connecting or disconnecting a hose. Ascertain that a hose is fully depressurized before disconnecting it. Before blowing compressed air through a hose or air line, ensure that the open end is held securely, so that it cannot whip and cause injury.
- 5 The air line end connected to the outlet valve must be safeguarded with a safety cable, attached next to the valve.
- 6 No external force may be exerted on the air outlet valves, e.g. by pulling on hoses or by installing auxiliary equipment directly to a valve, e.g. a water separator, a lubricator, etc. Do not step on the air outlet valves.
- 7 Never move a unit when external lines or hoses are connected to the outlet valves, to avoid damage to valves, manifold and hoses.
- 8 Do not use compressed air from any type of compressor, without taking extra measures, for breathing purposes as this may result in injury or death. For breathing air quality, the compressed air must be adequately purified according to local legislation and standards. Breathing air must always be supplied at stable, suitable pressure.
- 9 Distribution pipework and air hoses must be of correct diameter and suitable for the working pressure. Never use frayed, damaged or deteriorated hoses. Replace hoses and flexibles before the lifetime expires. Use only the correct type and size of hose end fittings and connections.
- 10 If the compressor is to be used for sand-blasting or will be connected to a common compressed-air system, fit an appropriate non-return valve (check valve) between compressor outlet and the connected sand-blasting or compressed-air system. Observe the right mounting position/direction.
- 11 Before removing the oil filler plug, ensure that the pressure is released by opening an air outlet valve.
- 12 Never remove a filler cap of the cooling water system of a hot engine. Wait until the engine has sufficiently cooled down.
- 13 Never refill fuel while the unit is running, unless otherwise stated in the Atlas Copco Instruction Book (AIB). Keep fuel away from hot parts such as air outlet pipes or the engine exhaust. Do not smoke when fuelling. When fuelling from an automatic pump, an earthing cable should be connected to the unit to discharge static electricity. Never spill nor leave oil, fuel, coolant or cleansing agent in or around the unit.

- 14 All doors shall be shut during operation so as not to disturb the cooling air flow inside the bodywork and/or render the silencing less effective. A door should be kept open for a short period only e.g. for inspection or adjustment.
- 15 Periodically carry out maintenance works according to the maintenance schedule.
- 16 Stationary housing guards are provided on all rotating or reciprocating parts not otherwise protected and which may be hazardous to personnel. Machinery shall never be put into operation, when such guards have been removed, before the guards are securely reinstalled.
- 17 Noise, even at reasonable levels, can cause irritation and disturbance which, over a long period of time, may cause severe injuries to the nervous system of human beings.
When the sound pressure level, at any point where personnel normally has to attend, is:
 - below 70 dB(A): no action needs to be taken,
 - above 70 dB(A): noise-protective devices should be provided for people continuously being present in the room,
 - below 85 dB(A): no action needs to be taken for occasional visitors staying a limited time only,
 - above 85 dB(A): room to be classified as a noise-hazardous area and an obvious warning shall be placed permanently at each entrance to alert people entering the room, for even relatively short times, about the need to wear ear protectors,
 - above 95 dB(A): the warning(s) at the entrance(s) shall be completed with the recommendation that also occasional visitors shall wear ear protectors,
 - above 105 dB(A): special ear protectors that are adequate for this noise level and the spectral composition of the noise shall be provided and a special warning to that effect shall be placed at each entrance.
- 18 Insulation or safety guards of parts the temperature of which can be in excess of 80 °C (175 °F) and which may be accidentally touched by personnel shall not be removed before the parts have cooled to room temperature.
- 19 Never operate the unit in surroundings where there is a possibility of taking in flammable or toxic fumes.
- 20 If the working process produces fumes, dust or vibration hazards, etc., take the necessary steps to eliminate the risk of personnel injury.
- 21 When using compressed air or inert gas to clean down equipment, do so with caution and use the appropriate protection, at least safety glasses, for the operator as well as for any bystander. Do not apply compressed air or inert gas to your skin or direct an air or gas stream at people. Never use it to clean dirt from your clothes.
- 22 When washing parts in or with a cleaning solvent, provide the required ventilation and use appropriate protection such as a breathing filter, safety glasses, rubber apron and gloves, etc.
- 23 Safety shoes should be compulsory in any workshop and if there is a risk, however small, of falling objects, wearing of a safety helmet should be included.
- 24 If there is a risk of inhaling hazardous gases, fumes or dust, the respiratory organs must be protected and depending on the nature of the hazard, so must the eyes and skin.
- 25 Remember that where there is visible dust, the finer, invisible particles will almost certainly be present too; but the fact that no dust can be seen is not a reliable indication that dangerous, invisible dust is not present in the air.
- 26 Never operate the unit at pressures or speeds below or in excess of its limits as indicated in the technical specifications.

1.5 SAFETY DURING MAINTENANCE AND REPAIR

Maintenance, overhaul and repair work shall only be carried out by adequately trained personnel; if required, under supervision of someone qualified for the job.

- 1 Use only the correct tools for maintenance and repair work, and only tools which are in good condition.
- 2 Parts shall only be replaced by genuine Atlas Copco replacement parts.
- 3 All maintenance work, other than routine attention, shall only be undertaken when the unit is stopped. Steps shall be taken to prevent inadvertent starting. In addition, a warning sign bearing a legend such as "work in progress; do not start" shall be attached to the starting equipment.
On engine-driven units the battery shall be disconnected and removed or the terminals covered by insulating caps.
On electrically driven units the main switch shall be locked in open position and the fuses shall be taken out. A warning sign bearing a legend such as "work in progress; do not supply voltage" shall be attached to the fuse box or main switch.
- 4 Before dismantling any pressurized component, the compressor or equipment shall be effectively isolated from all sources of pressure and the entire system shall be relieved of pressure. Do not rely on non-return valves (check valves) to isolate pressure systems. In addition, a warning sign bearing a legend such as "work in progress; do not open" shall be attached to each of the outlet valves.
- 5 Prior to stripping an engine or other machine or undertaking major overhaul on it, prevent all movable parts from rolling over or moving.
- 6 Make sure that no tools, loose parts or rags are left in or on the machine. Never leave rags or loose clothing near the engine air intake.
- 7 Never use flammable solvents for cleaning (fire-risk).
- 8 Take safety precautions against toxic vapours of cleaning liquids.
- 9 Never use machine parts as a climbing aid.
- 10 Observe scrupulous cleanliness during maintenance and repair. Keep away dirt, cover the parts and exposed openings with a clean cloth, paper or tape.
- 11 Never weld on or perform any operation involving heat near the fuel or oil systems. Fuel and oil tanks must be completely purged, e.g. by steam-cleaning, before carrying out such operations. Never weld on, or in any way modify, pressure vessels. Disconnect the alternator cables during arc welding on the unit.
- 12 Support the towbar and the axle(s) securely if working underneath the unit or when removing a wheel. Do not rely on jacks.
- 13 Do not remove any of, or tamper with, the sound-damping material. Keep the material free of dirt and liquids such as fuel, oil and cleansing agents. If any sound-damping material is damaged, replace it to prevent the sound pressure level from increasing.
- 14 Use only lubricating oils and greases recommended or approved by Atlas Copco or the machine manufacturer. Ascertain that the selected lubricants comply with all applicable safety regulations, especially with regard to explosion or fire-risk and the possibility of decomposition or generation of hazardous gases. Never mix synthetic with mineral oil.
- 15 Protect the engine, alternator, air intake filter, electrical and regulating components, etc., to prevent moisture ingress, e.g. when steam-cleaning.
- 16 When performing any operation involving heat, flames or sparks on a machine, the surrounding components shall first be screened with non-flammable material.
- 17 Never use a light source with open flame for inspecting the interior of a machine.

- 18 When repair has been completed, the machine shall be barred over at least one revolution for reciprocating machines, several revolutions for rotary ones to ensure that there is no mechanical interference within the machine or driver. Check the direction of rotation of electric motors when starting up the machine initially and after any alteration to the electrical connection(s) or switch gear, to check that the oil pump and the fan function properly.
- 19 Maintenance and repair work should be recorded in an operator's logbook for all machinery. Frequency and nature of repairs can reveal unsafe conditions.
- 20 When hot parts have to be handled, e.g. shrink fitting, special heat-resistant gloves shall be used and, if required, other body protection shall be applied.
- 21 When using cartridge type breathing filter equipment, ascertain that the correct type of cartridge is used and that its useful service life is not surpassed.
- 22 Make sure that oil, solvents and other substances likely to pollute the environment are properly disposed of.
- 23 Before clearing the unit for use after maintenance or overhaul, check that operating pressures, temperatures and speeds are correct and that the control and shutdown devices function correctly.

1.6 TOOL APPLICATIONS SAFETY

Apply the proper tool for each job. With the knowledge of correct tool use and knowing the limitations of tools, along with some common sense, many accidents can be prevented:

Special service tools are available for specific jobs and should be used when recommended. The use of these tools will save time and prevent damage to parts.

1.7 SPECIFIC SAFETY PRECAUTIONS

Batteries

When servicing batteries, always wear protecting clothing and glasses.

- 1 The electrolyte in batteries is a sulphuric acid solution which is fatal if it hits your eyes, and which can cause burns if it contacts your skin. Therefore, be careful when handling batteries, e.g. when checking the charge condition.
- 2 Install a sign prohibiting fire, open flame and smoking at the post where batteries are being charged.
- 3 When batteries are being charged, an explosive gas mixture forms in the cells and might escape through the vent holes in the plugs. Thus an explosive atmosphere may form around the battery if ventilation is poor, and can remain in and around the battery for several hours after it has been charged. Therefore:
 - never smoke near batteries being, or having recently been, charged,
 - never break live circuits at battery terminals, because a spark usually occurs.
- 4 When connecting an auxiliary battery (AB) in parallel to the unit battery (CB) with booster cables: connect the + pole of AB to the + pole of CB, then connect the - pole of CB to the mass of the unit. Disconnect in the reverse order.

Pressure vessels

(according to directive 87/404/EEC annex II § 2)

Maintenance/installation requirements:

- 1 The vessel can be used as pressure vessel or as separator and is designed to hold compressed air for the following application:
 - pressure vessel for compressor,
 - medium AIR/OIL,

and operates as detailed on the data plate of the vessel:

 - the maximum working pressure p_s in bar,
 - the maximum working temperature T_{max} in °C,
 - the minimum working temperature T_{min} in °C,
 - the capacity of the vessel V in l.
- 2 The pressure vessel is only to be used for the applications as specified above and in accordance with the technical specifications. Safety reasons prohibit any other applications.
- 3 National legislation requirements with respect to re-inspection must be complied with.
- 4 No welding or heat treatment of any kind is permitted to those vessel walls which are exposed to pressure.
- 5 The vessel is provided and may only be used with the required safety equipment such as manometer, overpressure control devices, safety valve, etc.
- 6 Draining of condensate shall be performed regularly when vessel is in use.
- 7 Installation, design and connections should not be changed.
- 8 Bolts of cover and flanges may not be used for extra fixation.

Safety valves

All adjustments or repairs are to be done by an authorized representative of the valve supplier (see maintenance schedule 4.2).

2. LEADING PARTICULARS

2.1 DESCRIPTION OF SAFETY PICTOGRAMS USED IN THIS MANUAL



This symbol draws your attention to dangerous situations. The operation concerned may endanger persons and cause injuries.



This symbol is followed by supplementary information.

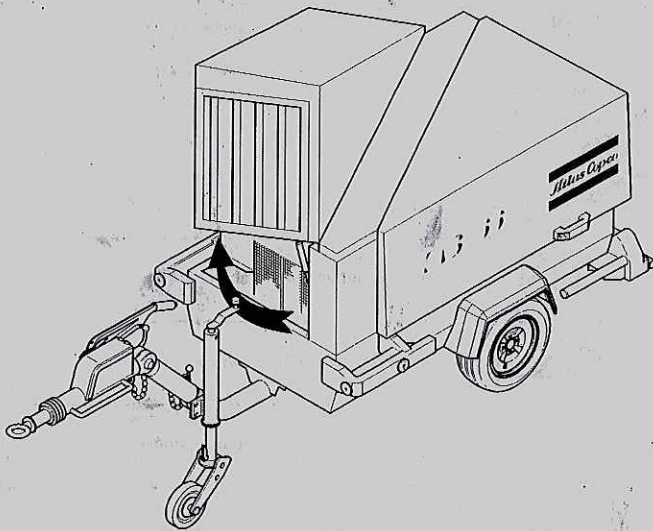

Fig. 2.1 General view of XAS66 Dd with open door
(adjustable towbar with brakes and jockey wheel are options)

2.2 GENERAL DESCRIPTION

The XAS66 Dd is a silenced, single-stage, oil-injected screw compressor, built for a nominal effective working pressure of 7 bar.

– Engine

The compressor is driven by a oil-cooled diesel engine. The engine's power is transmitted to the compressor through a heavy-duty drive belt.

– Compressor

The compressor casing houses two screw-type rotors, mounted on ball and roller bearings. The male rotor, driven by the engine, drives the female rotor. The element delivers pulsation-free air.

Injected oil is used for sealing, cooling and lubricating purposes.

– Compressor oil system

The oil is boosted by air pressure. The system has no oil pump.

The oil is removed from the air, in the air/oil vessel first by centrifugal force, second through the oil separator element.

The vessel is provided with an oil level indicator.

– Regulation

The compressor is provided with a continuous regulating system and a blow-down valve which is integrated in the unloader assembly. The valve is closed during operation by outlet pressure of the compressor element and opens by air receiver pressure when the compressor is stopped.

When the air consumption increases, the air receiver pressure will decrease and vice versa.

This receiver pressure variation is sensed by the regulating valve which, by means of control air to the unloader and engine speed regulator, matches the air output to the air consumption. The air receiver pressure is maintained between the pre-selected working pressure and the corresponding unloading pressure.

– Cooling system

Engine and compressor are provided with an oil cooler. The cooling air is generated by fan, driven by the engine.

– Safety devices

A thermal shut-down switch protects the compressor against overheating. The air receiver is provided with a safety valve.

The engine is equipped with low oil pressure and high oil temperature shut-down switches.

– Frame and axle

The compressor/engine unit is supported by rubber buffers in the frame.

The standard unit has a non-adjustable towbar with a towing eye.

As an option the unit can be equipped with an adjustable towbar, an overrun and parking brake and towing eyes type AC, DIN, ball, ITA, GB, NATO (for options see chapter 7).

The new braking system consists of an integrated parking brake and overrunbrake. When driving backwards the overrunbrake is not engaged automatically.

– Bodywork

The bodywork has openings at the shaped front and rear end for the intake and outlet of cooling air and hinged doors for maintenance and service operations. The bodywork is internally lined with sound-absorbing material.

– Lifting eye

A lifting eye is accessible when a small door at the top of the unit is unlocked.

– Control panel

The control panel grouping the air pressure gauge, control switch etc., is placed behind a transparent panel at the right hand/ rear end corner.



















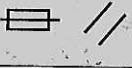

– Data plate











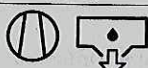

The compressor is furnished with a data plate showing the product code, the unit number and the working pressure (see chapter 10).

– Serial number

The serial number is located on the right-hand side towards the front on the upper edge of the frame.

2.3 MARKINGS AND INFORMATION LABELS

	Compressor outlet temperature too high.
	Compressor outlet temperature.
	Compressor outlet pressure.
	Dangerous outlet.
	Danger, heat flat.
	Electrocution hazard.
	Atlas Copco mineral compressor oil.
	Atlas Copco synthetic compressor oil.
	Atlas Copco mineral engine oil.
	Manual.
	Read the instruction manual before working on the battery.
	Reset fuse.
	On / off button.
	Manual override switch.
	Hours, time.
	Prohibition to open air valves without connected hoses.
	Compressor loaded.
	Runlamp.
	Airfilter.
	Compressor temperature too high.
	Rotation direction.

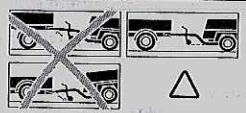
	Inlet.
	Outlet.
	Compressor oil drain.
	Read the instruction manual before starting.
	Service every 24 hours.
	Warning! Part under pressure.
	Do not stand on outlet valves.
	Start-Stop indication of switch.
	Do not run the motor with open doors.
	Lifting permitted.
	Use diesel fuel only.
2.7 bar / 39 psi	Tyre pressure.
	Sound power level in accordance with Directive 84/533/EC (expressed in dB (A)).
	Horizontal towbar position required in case of coupling.

2.4 MAIN PARTS

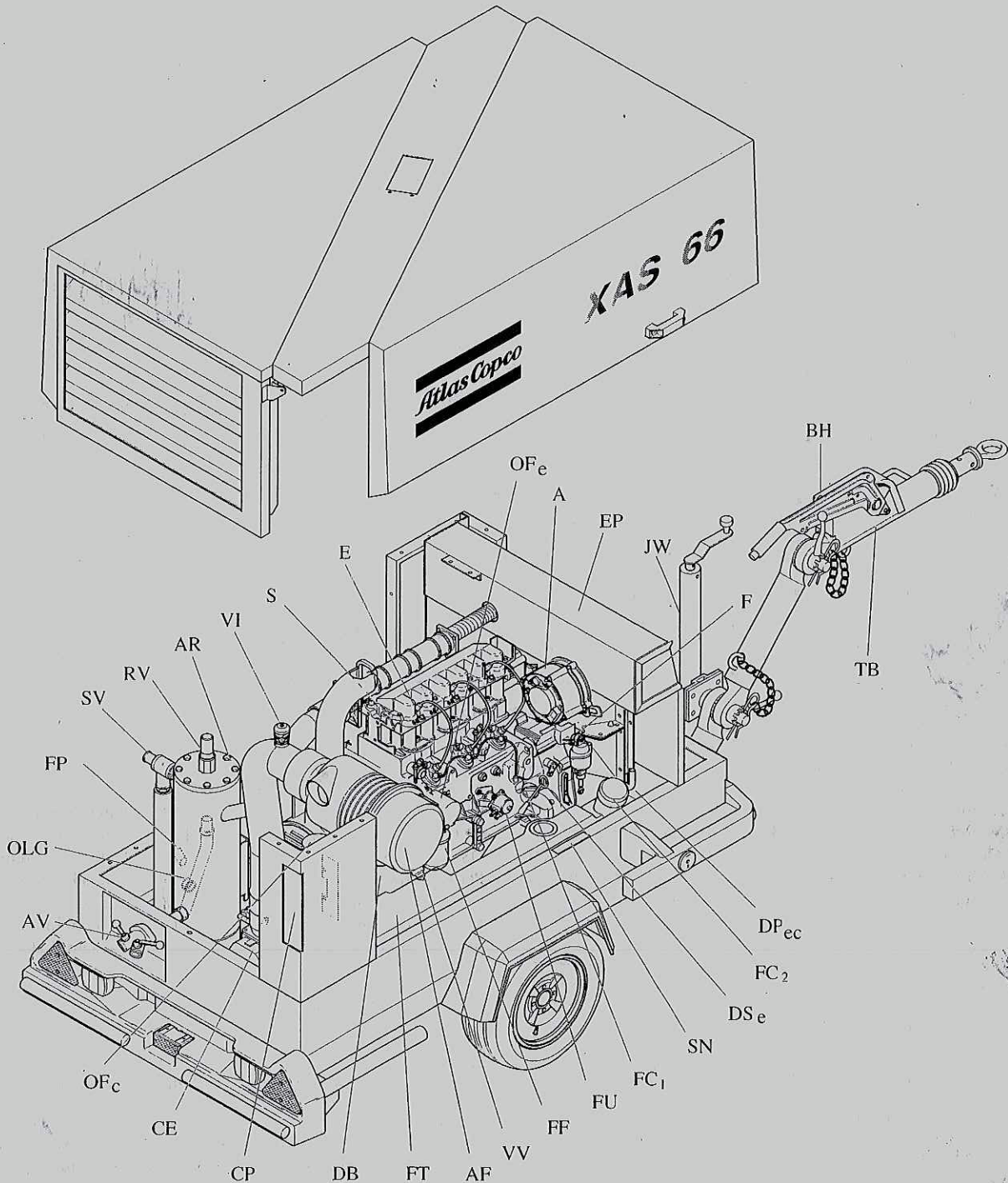

Fig. 2.2 Main parts of XAS66 Dd (adjustable towbar, jockey wheel brakes and roadsignalisation are options)

A	Alternator	E	Engine	OF _c	Oil Filter (compressor)
AF	Air Filter (for engine and compressor)	EP	Exhaust Pipe	OF _e	Oil Filter (engine)
AR	Air Receiver	F	Fan	OLG	Oil Level Gauge
AV	Air outlet valves	FC ₁	Filler Cap (engine oil)	RV	Regulating Valve
BH	Brake Handle	FC ₂	Filler Cap (fuel tank)	S	Starting Motor
CE	Compressor Element	FF	Fuel Filter	SN	Serial Number
CP	Control Panel	FP	Filler Plug (compressor oil)	SV	Safety Valve
DB	Drive Belt	FT	Fuel Tank	TB	Towbar
DP _{ec}	Drain Plug Engine Oil Cooler	FU	Fuel Pump	VI	Vacuum Indicator
DS _e	Engine Oil Level Dipstick	JW	Jockey Wheel	VV	Vacuator Valve

COMPRESSOR REGULATING SYSTEM

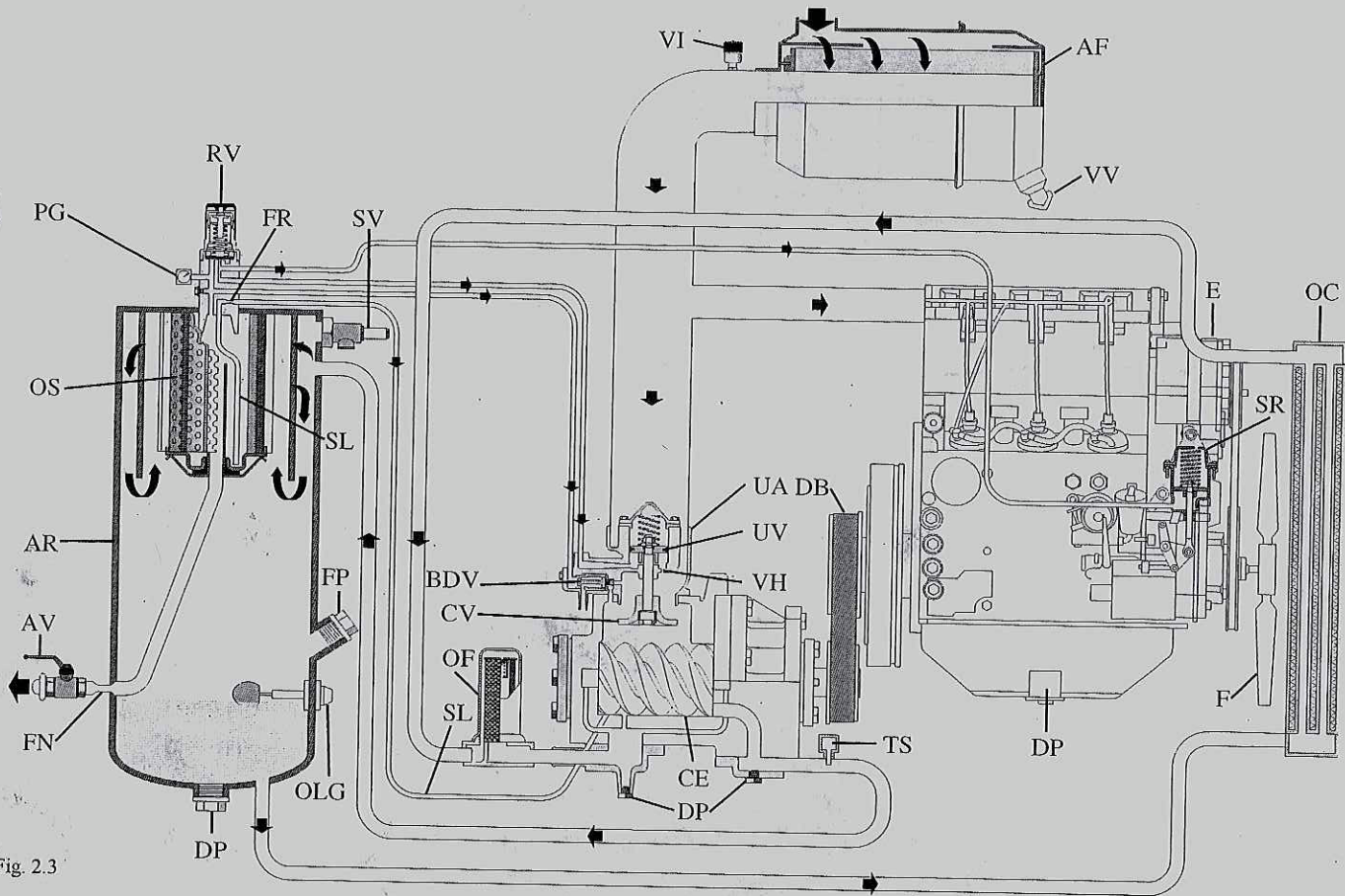

Fig. 2.3

AF	Air Filter	DP	Drain Plug	OF	Oil Filter	SV	Safety Valve
AR	Air Receiver	E	Engine	OLG	Oil Level Gauge	TS	Temperature Switch
AV	Air Outlet Valves	F	Fan	OS	Oil Separator	UA	Unloader Assembly
BDV	Blow Down Valve	FN	Flow Nozzle	PG	Pressure Gauge	UV	Unloader Valve
CE	Compressor Element	FP	Filling Plug	RV	Regulating Valve	VH	Vent Hole
CV	Check Valve	FR	Flow Restrictor	SL	Scavenge Line	VI	Vacuum Indicator
DB	Drive belt	OC	Oil Cooler	SR	Speed Regulator	VV	Vacuator Valve

2.5 AIR FLOW (SEE FIG. 2.3)

The system comprises:

- AF Air filter
- AR/OS Air receiver/oil separator
- CE Compressor element
- UA/UV Unloader assembly with unloader valve
- BDV Blow-down valve
- FN Flow nozzle

Air drawn through the airfilter (AF) into the compressor element (CE) is compressed. At the element outlet, compressed air and oil pass into the air receiver/oil separator (AR/OS).

The check valve (CV) prevents blow-back of compressed air when the compressor is stopped. In the air receiver/oil separator (AR/OS), most of the oil is removed from the air/oil mixture; the remaining oil is removed by the separator element.

The oil collects in the receiver and on the bottom of the separator element.

The air leaves the receiver via a flow nozzle (FN) which prevents the receiver pressure from dropping below the minimum working pressure (specified in section 9.3), even when the air outlet valves are open. This ensures adequate oil injection and prevents oil consumption.

A temperature switch (TS) and a working pressure gauge (PG) are comprised in the system.

A blow-down valve (BDV) is fitted in the unloader assembly to automatically depressurise the air receiver (AR) when the compressor is stopped.

2.6 OIL SYSTEM (SEE FIG. 2.3)

The system comprises:

AR/OS	Air receiver/oil separator
OC	Oil cooler
OF	Oil filter

The lower part of the air receiver (AR) serves as oil tank.

Air pressure forces the oil from the air receiver/oil separator (AR/OS) through the oil cooler (OC) and oil filter (OF) to the compressor element (CE).

The compressor element has an oil gallery in the bottom of its casing. The oil for rotor lubrication, cooling and sealing is injected through holes in the gallery.

Lubrication of the bearings is ensured by oil injected into the bearing housings.

The injected oil, mixed with the compressed air, leaves the compressor element and re-enters the air receiver, where it is separated from the air as described in section 2.5. The oil that collects in the bottom of the oil separator element is returned to the system through scavenging line (SL), which is provided with a flow restrictor (FR).

The oil filter by-pass valve opens when the pressure drop over the filter is above normal because of a clogged filter. The oil then by-passes the filter without being filtered. For this reason, the oil filter must be replaced at regular intervals (see section 4.2).

2.7 CONTINUOUS REGULATING SYSTEM (SEE FIG. 2.3)

The system comprises:

RV	Regulating valve
UA	Unloader assembly
SR	Speed regulator

The compressor is provided with a continuous regulating system. This system is provided with a blow-down valve which is integrated in the unloader assembly (UA). The valve is closed during operation by outlet pressure of the compressor element and opens by air receiver pressure when the compressor is stopped.

When the air consumption increases, the air receiver pressure will decrease and vice versa. This receiver pressure variation is sensed by the regulating valve which, by means of control air to the unloader, matches the air output to the air consumption. The air receiver pressure is maintained between the pre-selected working pressure and the corresponding unloading pressure.

When starting the compressor, the unloader valve (UV) is kept open by spring force, the engine runs at maximum speed. The compressor element (CE) takes in air and pressure builds up in the receiver.

The air output is controlled from maximum output (100%) to no output (0%) by:

1. Speed control of the engine between maximum load speed and unloading speed (the output of a screw compressor is proportional to the rotating speed).
2. Air inlet throttling.

If the air consumption is equal to or exceeds the maximum air output, the engine speed is held at maximum load speed and the unloading valve is fully open.

If the air consumption is less than the maximum air output, the regulating valve supplies control air to unloader valve (UV) to reduce the air output and holds air receiver pressure between the normal working pressure and the corresponding unloading pressure of approx. 1.5 bar above the normal working pressure.

When the air consumption is resumed, the unloader valve (UV) gradually opens the air intake and the speed regulator (SR) increases the engine speed.

The construction of the regulating valve (RV) is such that any increase (decrease) of the air receiver pressure above the pre-set valve opening pressure results in a proportional increase (decrease) of the control pressure to the unloading valve and the speed regulator.

Part of the control air is vented to the atmosphere, and any condensate discharged, through the vent holes (VH).

2.8 ELECTRICAL SYSTEM

2.8.1 CIRCUIT DIAGRAM

The compressor is equipped with a negative earthed system.

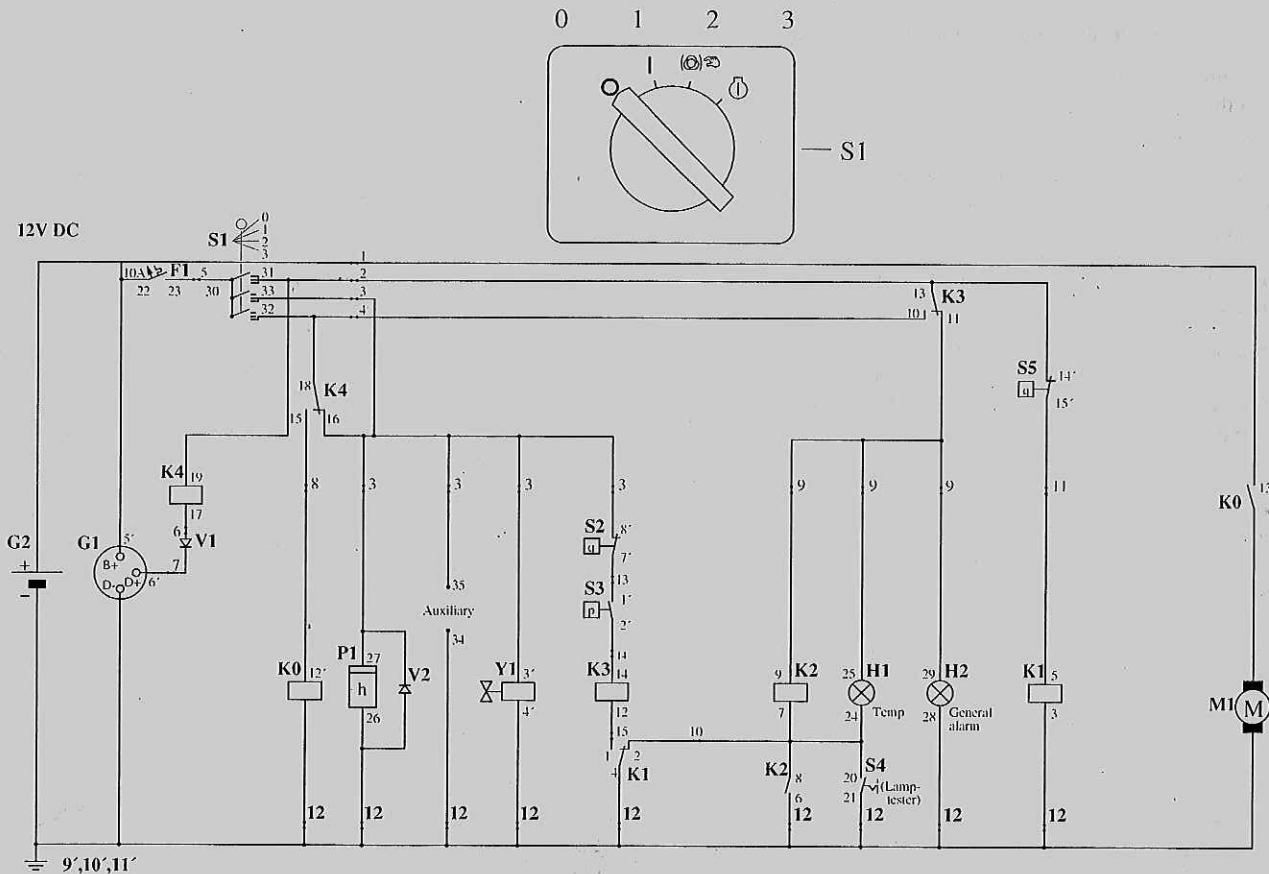

Fig. 2.4 Circuit diagram (No. 9822 0797 01)

- | | | | |
|----|-------------------------------|----|--|
| F1 | Circuit Breaker (10 A) | M1 | Starter Motor |
| G1 | Alternator | P1 | Hourmeter |
| G2 | Battery | S1 | Contact Switch (Off-On-Override-start) |
| H1 | Temperature Alarm Lamp | S2 | Temperature Switch Engine |
| H2 | General Alarm Lamp | S3 | Oil Pressure Switch Engine |
| K0 | Starter Solenoid (part of M1) | S4 | Temperature Lamp-test Switch |
| K1 | Shut-down Relay | S5 | Temperature Switch Compressor |
| K2 | Blocking Relay | Y1 | Fuel Solenoid Valve |
| K3 | Override Start Relay | V1 | Diode |
| K4 | Start Relay | V2 | Diode |

2.8.2 DESCRIPTION

Operation of the electric circuit in detail

Start button S1 position 1:

Line 2 on 12V contact K3 closed (13-11), lamp H2 is on. K4 excites contact K4 (18-15). Thermocontact element S5 normally closed, K1 excites contact K1 (1-4).

Use of lamp test:

Start button S1 position 1 press lamp test S4, across K3 and line 9 lamp H1 and relay K2 are excited. After releasing lamp test button S4, lamp H1 remains on, S4 taken over by contact K2.

Start button S1 position 2:

Line 3 on 12V (overwrite function) hourmeter P1 and fuel solenoid Y1 excited. Thermocontact engine S2 normally closed, oil pressure contact S3 open.

Start button S1 position 3:

Start relay K0 is excited and starter motor is running, engine builds up oil pressure and oil pressure contact S3 closes. K3 excited and contact K3 changes over to (13-10). Relay K2 no longer excited, contact K2 opens, lamp H1 goes out. Alternator also commences supplying voltage and K4 is no longer excited and contact K4 changes over to (18-16). Lamp H2 goes out, one can release start button S1 and it returns to position 1. Exciting the safety devices occurs no longer across line 3 but across line 2 to line 4 and this way to line 3.

Engine is running normally:

Oil pressure contact S3 opens, K3 no longer excited. K3 changes over (13-11), engine cuts out because fuel solenoid Y1 no longer excited and lamp H2 goes on simultaneously.

Thermocontact S2 opens, K3 no longer excited. K3 changes over (13-11), engine cuts out because fuel solenoid Y1 no longer excited and lamp H2 goes on simultaneously.

Thermocontact S5 opens, K1 no longer excited. Contact K1 changes over (4-2). K3 no longer excited. K3 changes over (13-11), engine cuts out because fuel solenoid Y1 no longer excited and lamp H2 and H1 go on simultaneously. Take-over relay K2 is excited simultaneously with H1 and contact K2 closes (8-6).

Thermocontact S5 cools off and closes, K1 excited again and contact K1 changes over (4-1). However, lamp H1 remains on across line 9 and contact K2 (6-8).

A fault in the alternator part causes terminal D+ to go to 0V and K4 to be excited. Contact K4 changes over to (18-15), engine cuts out because fuel solenoid Y1 no longer excited and lamp H2 goes on simultaneously.

3. OPERATING INSTRUCTIONS

3.1 PARKING, TOWING AND LIFTING INSTRUCTIONS

Safety precautions.



The operator is expected to apply all relevant safety precautions, including those mentioned on the pages 5 - 8 of this book.

Attention:

- Before putting the compressor in to use, check the brake system as described in section 5.6.
- After the first 100 km travel:
 - Check and retighten the wheel nuts and towbar bolts to the specified torque. See section 3.1.3 and 9.1.
 - Check the brake adjustment. See section 5.6.

3.1.1 PARKING INSTRUCTIONS

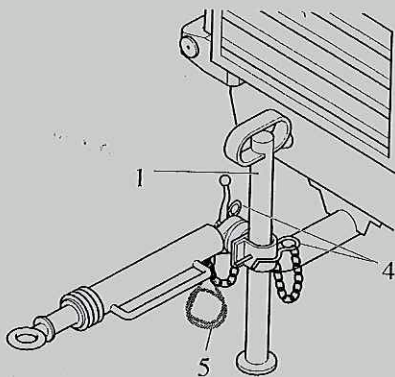

Fig. 3.1 Non-adjustable towbar with standard prop without brakes

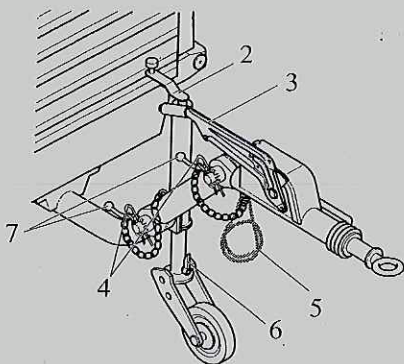

Fig. 3.2 Adjustable towbar with jockey wheel and brakes

When parking a compressor, secure prop (1) or jockey wheel (2) to support the compressor in a level position. Be sure that the jockey wheel (2) is blocked by the blocking pin (6).

Apply parking brake by pulling parking brake handle (3) upwards. Place the compressor as level as possible; however, it can be operated temporarily in an out-of-level position not exceeding 15°. If the compressor is parked on sloping ground, immobilise the compressor by placing wheel chocks (available as option) in front of or behind the wheels. Locate the rear-end of the compressor upwind, (see Fig. 3.4), away from contaminated wind-streams and walls. Avoid recirculation of exhaust air from the engine. This causes overheating and engine power decrease.

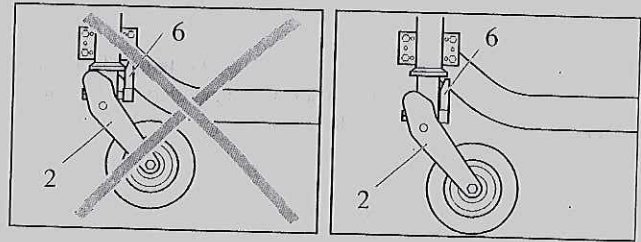

Fig. 3.3 Parking position of jockey wheel

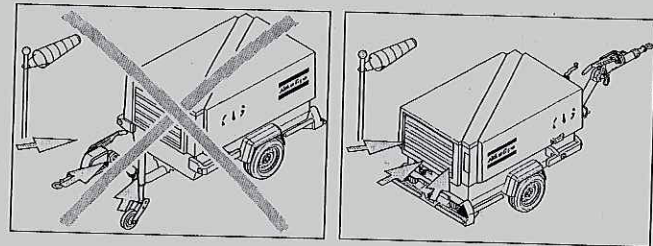

Fig. 3.4 Rear-end of compressor upwind

3.1.2 TOWING INSTRUCTIONS



Before towing the compressor, make sure that the towing equipment of the vehicle matches the towing eye or ball connector.

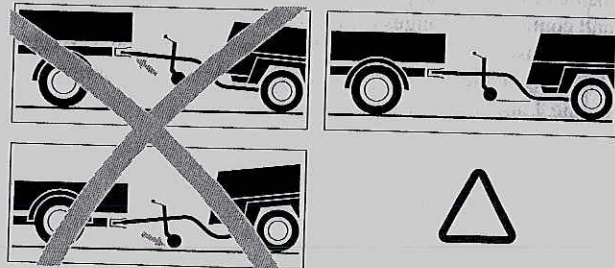

Fig. 3.5 Label on towbar, towing instructions

For both non-adjustable - and adjustable towbar, the towbar should be as level as possible and the compressor and towing eye end in a level position.

Push the hand brake lever (3) completely downwards and connect breakaway cable (5) to the vehicle. Secure jockey wheel (2) or prop (1) in the highest possible position. The jockey wheel is prevented from turning.

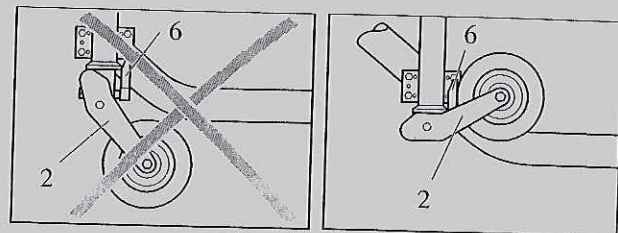

Fig. 3.6 Towing position of jockey wheel

3.1.3 HEIGHT ADJUSTMENT (WITH ADJUSTABLE TOWBAR)

! Before towing the compressor, make sure that the joints of the towbar are secured with maximum strength without damaging the towbar. Be sure that there is no clearance between the teeth of the joints.

For specific instruction see below!

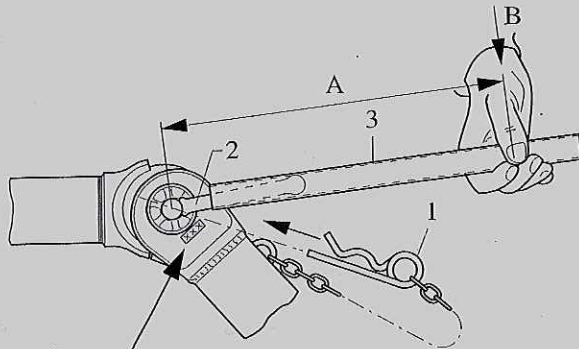

Fig. 3.7

Table

X X X	M _A [Nm]	"A" [mm]	"B" [N]
ZV 2000	250 - 300	600	420 - 500
ZV 2500	350 - 400	600	580 - 660

Fig. 3.8

- Remove spring pin (1).
- Release locking nut (2) with support tools (Extension tube 3).
- Adjust required height of the drawbar.
- Tighten locking nut (2) by hand first.
- Secondly tighten locking nut (2) with a tightening torque corresponding to table (Fig. 3.8). With an extension tube (3) ("A" corresponding to table) and handforce ("B" corresponding to table) easy tightening is possible.
- Fix locking nut (2) with spring pin (1).

! **Attention:**

- Height adjustment should be undertaken on levelled ground and in coupled condition.
- When readjusting, make sure that the front point of the drawbar is horizontal to the coupling point.
- Before starting a trip, make sure that the adjustment shaft is secure, so that the stability and safety is guaranteed while driving. If necessary tighten the locking nut (2) corresponding to table (Fig. 3.8).

3.1.4 LIFTING INSTRUCTIONS

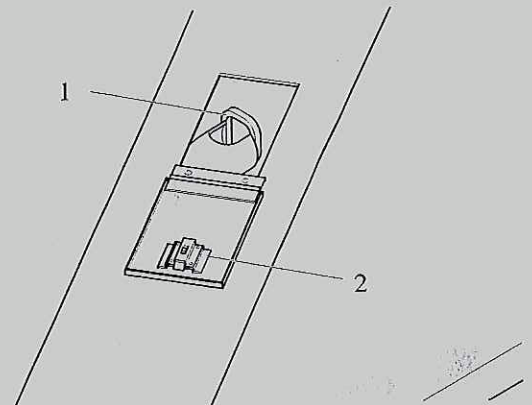

Fig. 3.9 Lifting eye

When lifting the compressor, the hoist has to be placed in such a way that the compressor, which must be placed level, will be lifted vertically. Keep lifting acceleration and retardation within safe limits. Preferably use the lifting eye (1) after opening the small door (2).

! Lifting acceleration and retardation must be kept within safe limits (max. 4xg). Helicopter lifting is not allowed.

3.2 BEFORE STARTING

1. Before initial start-up, prepare battery for operation if not already done. See section 4.7.
2. With the compressor standing level, check the level of the engine oil. Add oil, if necessary, to the upper mark on dipstick. Consult the Engine Operation Manual for the type and viscosity grade of the engine oil.
3. Check the level of the compressor oil. The pointer of oil level gauge (Fig. 2.3, OLG) should register in the green range. Add oil if necessary. See section 4.3 for the oil to be used.

! Before removing oil filling plug (Fig. 2.3, FP), ensure that the pressure is released by opening an air outlet valve.

4. Check that the fuel tank contains sufficient fuel. Top up, if necessary. Consult the Engine Operation Manual for the type of fuel.
5. Drain any water and sediment from the fuel filter until clean fuel flows from the drain cock.
6. Press vacuator valves (Fig. 2.3, VV) of the air filters to remove dust.
7. Check the air filter vacuum indicators (Fig. 2.3, VI). If the yellow piston reaches the red marked service range, replace the filter element. Reset the indicator by pushing the reset button.
8. Open air outlet valve to allow air flow to the atmosphere.

3.3 STARTING/STOPPING

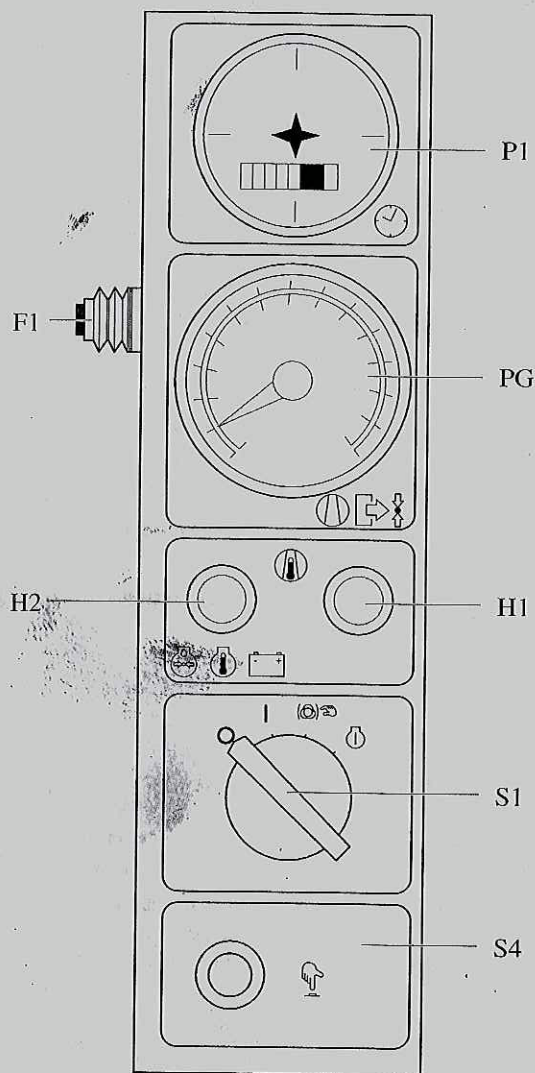

Fig. 3.10 Control panel

P1	Hourmeter
F1	Circuit breaker button
PG	Working pressure gauge
H1	Temperature alarm lamp (red)
H2	General alarm lamp (red)
S1	Contact switch
S4	Lamp test

Before starting, first operate the circuit breaker button (F1) at the left side of the control panel (open left-hand service door first).

To start, the start button is turned clockwise to position 1, lamp H2 (general alarm) will go on. When the button is turned further to position 3, the starter motor will set the engine in motion. Lamp H2 will go out as soon as the engine has been started. The start button automatically springs back to position 1. Lamp H1 only produces a signal when the compressor outlet temperature is too high. Correct operation of the lamp itself can be checked by operating the lamp test button S4 located on the control panel.

When the start button is in position 1 and the engine is not running, the lamp test can be used. Lamp H1 will go on and will automatically go out when the group is started.

Shutting-down is simply done by turning the start button anti-clockwise to position 0 (with valves closed).

The control panel in addition indicates receiver pressure (PG) and accumulated operating hours (P1).

Fault situations and protective devices:

- The starter motor is protected against prolonged starting or against attempts to start when the group is already running.
- A fault which occurs with the engine, either: oil pressure (too low), oil temperature (too high) or alternator voltage (too low) will always and immediately cause the engine to cut out and the control lamp H2 will light up. By doing some simple checks, it can be determined what it was that caused the engine to fail: low oil level, clogged-up cooler, slack alternator belt tension or broken belt.
- When the outlet temperature of the element becomes too high, a thermocontact will also switch off the group immediately. Both control lamps H1 and H2 will light up. Both control lamps will remain on until the group has been restarted (start button to position 3) or the contact is turned off (start button to position 0); also when, due to cooling off, the thermocontact has closed again (= memory function).

3.4 DURING OPERATION



The doors must be closed during operation and may be opened for short periods only.

Regularly carry out following checks:

1. That regulating valve (RV) is correctly adjusted, i.e. starts decreasing the engine speed when reaching the preset working pressure in the receiver.
2. Check the air filter vacuum indicator (VI - Fig. 2.3). If the yellow piston reaches the red marked service range, replace the filter element. Reset the indicator by pushing the reset button.
3. On compressors with aftercooler, check that the automatic drain of the water separator is operative without air leakage.

4. MAINTENANCE

4.1 USE OF SERVICE PAKS

Service Paks include all genuine parts needed for normal maintenance of both compressor and engine.

Service Paks minimise downtime and keep your maintenance budget low.

Order Service Paks at your local Atlas Copco dealer.

4.2 PREVENTIVE MAINTENANCE SCHEDULE FOR THE COMPRESSOR

The schedule contains a summary of the maintenance instructions. Read the respective section before taking maintenance measures.

When servicing, replace all disengaged packings, e.g. gaskets, O-rings, washers.

For engine maintenance refer to Engine Operation Manual.

The maintenance schedule has to be seen as a guideline for units operating in a duty environment typical to compressor applications. Maintenance schedule can be adapted depending on application environment and quality of maintenance.

MAINTENANCE SCHEDULE	Daily	Initially <i>or every 50 hours</i>	Normal <i>or every 500 hours</i>	Yearly <i>or every 1,000 hours</i>
Service pak		supplied with unit	2912 4199 02	2912 4275 06
Engine oil level	Check			
Compressor oil level	Check			
Air filter vacuator valves	Empty			
Fuel filter water drain	Drain			
Air intake vacuum indicators	Check			
Electrolyte level and terminals of battery		Check	Check	Check
Tyre pressure		Check	Check	Check
Leaks in air-, oil- or fuel system		Check	Check	Check
Oil cooler package			Clean	Clean
Engine minimum and maximum speeds		Check	Check	Check
Torque of wheel nuts		Check	Check	Check
Brake system (if installed)		Check/Adjust	Check/Adjust	Check/Adjust
Safety valve				Test
Door hinges			Grease	Grease
Coupling head and all its moving parts / shaft			Grease	Grease
Joints of height adjustment adjustable towbar		Check	Grease	Grease
Shutdown switches				Check
Pressure drop over separator element (2)			Measure	Replace
Fan V-belt (3)		Adjust	Adjust	Adjust
Fuel tank			Clean	Clean
Compressor oil				Change
Compressor oil filter		Replace		Replace
Air filter element (1)				Replace
Safety cartridge (1) (option)				Replace
Engine oil (3) (4) (6)		Change	Change	Change
Engine oil filter (3)		Replace	Replace	Replace
Fuel filter (3)		Replace		Replace
Engine inlet and outlet valves (3)				Adjust (5)

- (1) More frequently when operating in a dusty environment.
 (2) Replace the element when the pressure drop exceeds 0.8 bar.
 (3) Refer to the Deutz operation manual.
 (4) 500 hours only valid when using PAROIL SAE 15 W 40.

- (5) The valves need to be adjusted for the first time before 500 running hours. The rocker cover gasket is not included in the 500 hours kit. They are to be ordered separately: for 3 cyl.: PN 2914 8054 00
 (6) Also drain engine oil from engine oil cooler (see Fig. 2.2; DPec = Drain plug engine oil cooler)



Keep the bolts of the housing, the lifting eye, the towbar and the axle securely tightened. Refer to section 9 'Technical specifications' and section 3.1.3 for the torque values.

4.3 LUBRICATION OILS

High-quality, mineral, hydraulic or synthesized hydrocarbon oil with rust and oxidation inhibitors and anti-foam and anti-wear properties is recommended. The viscosity grade should correspond to the ambient temperature and ISO 3448, as follows:

Type of lubricant	Compressor**	Engine*
between 30°C and 40°C	PAROIL S	PAR OIL SAE 15W40
between 30°C and -5°C	PAROIL M PAROIL S	PAR OIL SAE 15W40
between -5°C and -20°C	PAROIL S	other brand of oil* SAE 5W40



*
If you want to use another brand of oil, consult the Engine Operation Manual.



**
It is strongly recommended to use Atlas Copco branded lubrication oils for the compressor. If you want to use another brand of oil, consult Atlas Copco.

Mineral compressor oil PAROIL M:

- 5 liter can: order number 1615 5947 00
- 20 liter can: order number 1615 5948 00
- 208 liter barrel: order number 1615 5949 00

Mineral engine oil PAROIL SAE 15 W 40:

- 5 liter can: order number 1615 5953 00
- 20 liter can: order number 1615 5954 00
- 208 liter barrel: order number 1615 5955 00

Synthetic compressor oil PAROIL S:

- 5 liter can: order number 1615 5950 00
- 19 liter can: order number 1615 5951 00
- 208 liter barrel: order number 1615 5952 00



Never mix synthetic with mineral oil.

Remark:

When changing from mineral to synthetic oil (or the other way around), you will need to do an extra rinse:

After doing the complete change procedure to synthetic oil, run the unit for a few minutes to allow good and complete circulation of the synthetic oil. Then drain the synthetic oil again and fill again with new synthetic oil.

To set correct oil levels, proceed as in normal instruction.

4.4 OIL LEVEL CHECK



Never mix oils of different brands or types.

Use only non-toxic oils where there is a risk of inhaling delivered air.

4.4.1 CHECK ENGINE OIL LEVEL

Consult also the Engine Operation Manual for the oil specifications, viscosity recommendations and oil change intervals.

See schedule 4.2.

Check engine oil level according to the instructions in the Engine Operation Manual and top up with oil if necessary.

4.4.2 CHECK COMPRESSOR OIL LEVEL

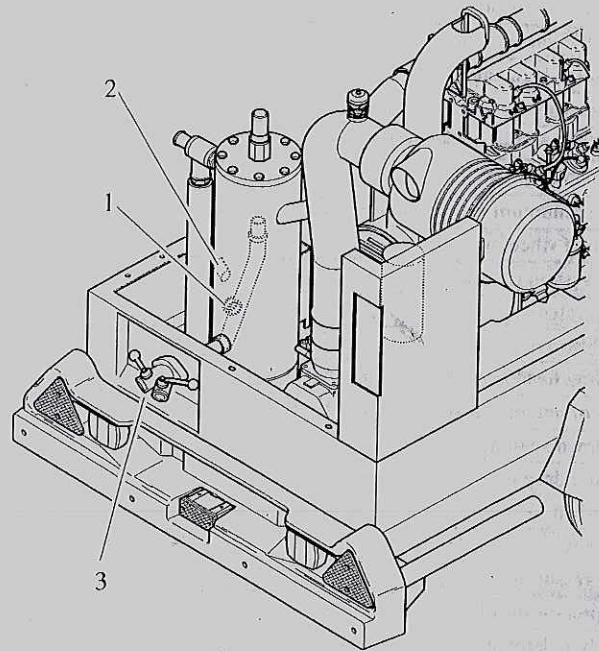

Fig. 4.1 Check compressor oil level

With the unit standing level, check the level of the compressor oil. The pointer of the oil level gauge (1) must register in the upper extremity of the green range. Add oil if necessary.



Before removing oil filler plug (2), ensure that the pressure is released by opening an air outlet valve (3).

4.5 OIL AND OIL FILTER CHANGE

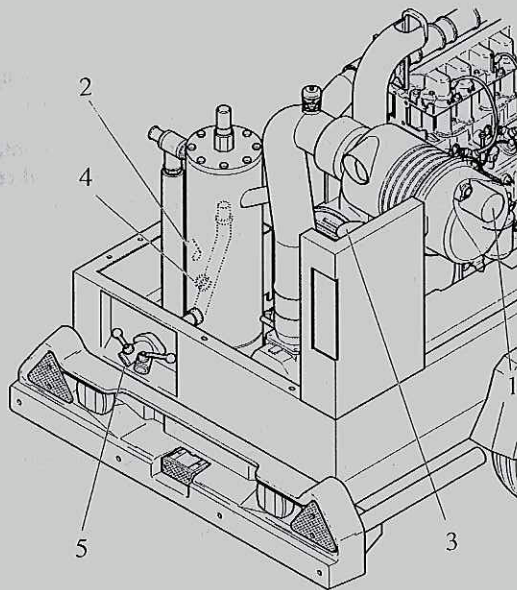

Fig. 4.2 Oil filters

4.5.1 ENGINE OIL AND OIL FILTER CHANGE

See section 4.2.

4.5.2 COMPRESSOR OIL AND OIL FILTER CHANGE

The quality and the temperature of the oil determine the oil change interval.

The prescribed interval (see section 4.2) is based on an oil temperature of up to 100 °C and normal operating conditions.

When operating in high ambient temperatures, in very dusty or high humidity conditions, it is recommended to change the oil more frequently.

 **In this case, contact Atlas Copco.**

1. Run the compressor until warm. Close the outlet valve(s) (5) and stop the compressor. Wait until the pressure is released through the automatic blow-down valve. Unscrew the oil filler plug (2) one turn. This uncovers a vent hole, which permits any pressure in the system to escape.
2. Drain the oil by removing all relevant drain plugs. Drain plugs are located at the air receiver and compressor element. Catch the oil in a drain pan. Screw out the filler plug to speed up draining. Tighten the plugs after draining.
3. Remove the oil filter (3), e.g. by means of a special tool. Catch the oil in a drain pan.
4. Clean the filter seat on the manifold, taking care that no dirt drops into the system. Oil the gasket of the new filter element. Screw it into place until the gasket contacts its seat, then tighten one half turn only.
5. Fill the air receiver until the pointer of the oil level gauge (4) registers in the upper extremity of the green range. Take care that no dirt drops into the system. Reinstall and tighten the filler plug.

6. Run the unit at no load for a few minutes to circulate the oil and to evacuate the air trapped in the oil system.
7. Stop the compressor. Let the oil settle for a few minutes. Check that the pressure is released by opening an air outlet valve (5). Screw out filler plug (2) and add oil until the pointer of the oil level gauge (4) again registers in the upper extremity of the green range. Reinstall and tighten the filler plug.



Never add more oil. Overfilling results in oil consumption.

4.6 CLEANING COOLERS

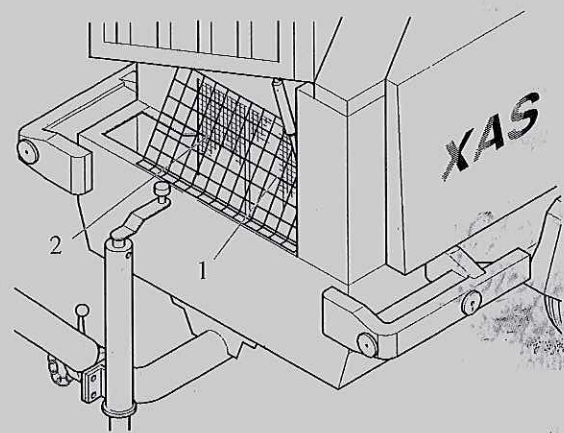

Fig. 4.3 Compressor oil cooler (1) and engine oil cooler (2)

Keep the oil-coolers (1) and (2) clean to maintain the cooling efficiency.

The fan side surface of compressor- and engine oil cooler is accessible by removing the fan cowl upper part.



Remove any dirt from the coolers with a fibre brush. Never use a wire brush or metal objects.

Steam cleaning in combination with a cleansing agent may be applied.



To avoid damaging the coolers, angle between jet and coolers should be approx. 90 °.



Protect the electrical and controlling equipment, air filters, etc. against penetration of moisture.

Close the service door(s).



Never leave spilled liquids such as fuel, oil, water and cleansing agents in or around the compressor.

4.7 BATTERY CARE



Before handling batteries, read the relevant safety precautions and act accordingly.

If the battery is still dry, it must be activated as described in section 4.7.2.

The battery must be in operation within 2 months from being activated; if not, it needs to be recharged first.

4.7.1 ELECTROLYTE



Read the safety instructions carefully.

Electrolyte in batteries is a sulphuric acid solution in distilled water.

The solution must be made up before being introduced into the battery.

4.7.2 ACTIVATING A DRY-CHARGED BATTERY

- Take out the battery.
- Battery and electrolyte must be at equal temperature above 10°C.
- Remove cover and/or plug from each cell.
- Fill each cell with electrolyte until the level reaches 10 to 15 mm above the plates, or to the level marked on the battery.
- Rock the battery a few times so that possible air bubbles can escape; wait 10 minutes and check the level in each cell once more; if required, add electrolyte.
- Refit plugs and/or cover.
- Place the battery in the compressor.

4.7.3 RECHARGING A BATTERY

Before and after charging a battery, always check the electrolyte level in each cell; if required, top up with distilled water only. When charging batteries, each cell must be open, i.e. plugs and/or cover removed.



Use a commercial automatic battery charger according to its manufacturer's instructions.

Apply with preference the slow charging method and adjust the charge current according to the following rule of thumb:

battery capacity in Ah divided by 20 gives safe charging current in Amp.

4.7.4 BATTERY MAINTENANCE

- Keep the battery clean and dry.
- Keep the electrolyte level at 10 to 15 mm above the plates or at the indicated level; top up with distilled water only.
- Keep the terminals and clamps tight, clean, and lightly covered with petroleum jelly.

4.8 STORAGE

Run the compressor regularly, e.g. twice a week, until warm.

Load and unload the compressor a few times to operate the unloading and regulating components. Close the air outlet valves after stopping.



If the compressor is going to be stored without running from time to time, protective measures must be taken as described in a separate Service Bulletin (ASB), which may be obtained on request.

4.9 SERVICE PAKS

A Service Pak is a collection of parts to be used for a specific maintenance measure, e.g. after 50, after 500 and after 1000 running hours.

It guarantees that all necessary parts are replaced at the same time keeping down time to a minimum.

The order number of the Service Paks are listed in the Atlas Copco Parts List (ASL).

4.10 SERVICE KITS

A Service Kit is a collection of parts to fit a specific repair or rebuilding task.

It guarantees that all necessary parts are replaced at the same time which improves the uptime of the unit.

The order numbers of the Service Kits are listed in the Atlas Copco Parts List (ASL).



Contact Atlas Copco.

4.11 COMPRESSOR ELEMENT OVERHAUL

When a compressor element is due for overhaul, it is recommended to have it done by Atlas Copco. This guarantees the use of genuine parts and correct tools with care and precision.

4.12 LIABILITY

The manufacturer does not accept any liability for any damage arising from the use of non-original parts and for modifications, additions or conversions made without the manufacturer's approval in writing.

5. ADJUSTMENTS AND SERVICING PROCEDURES

5.1 ADJUSTMENT OF THE CONTINUOUS REGULATING SYSTEM

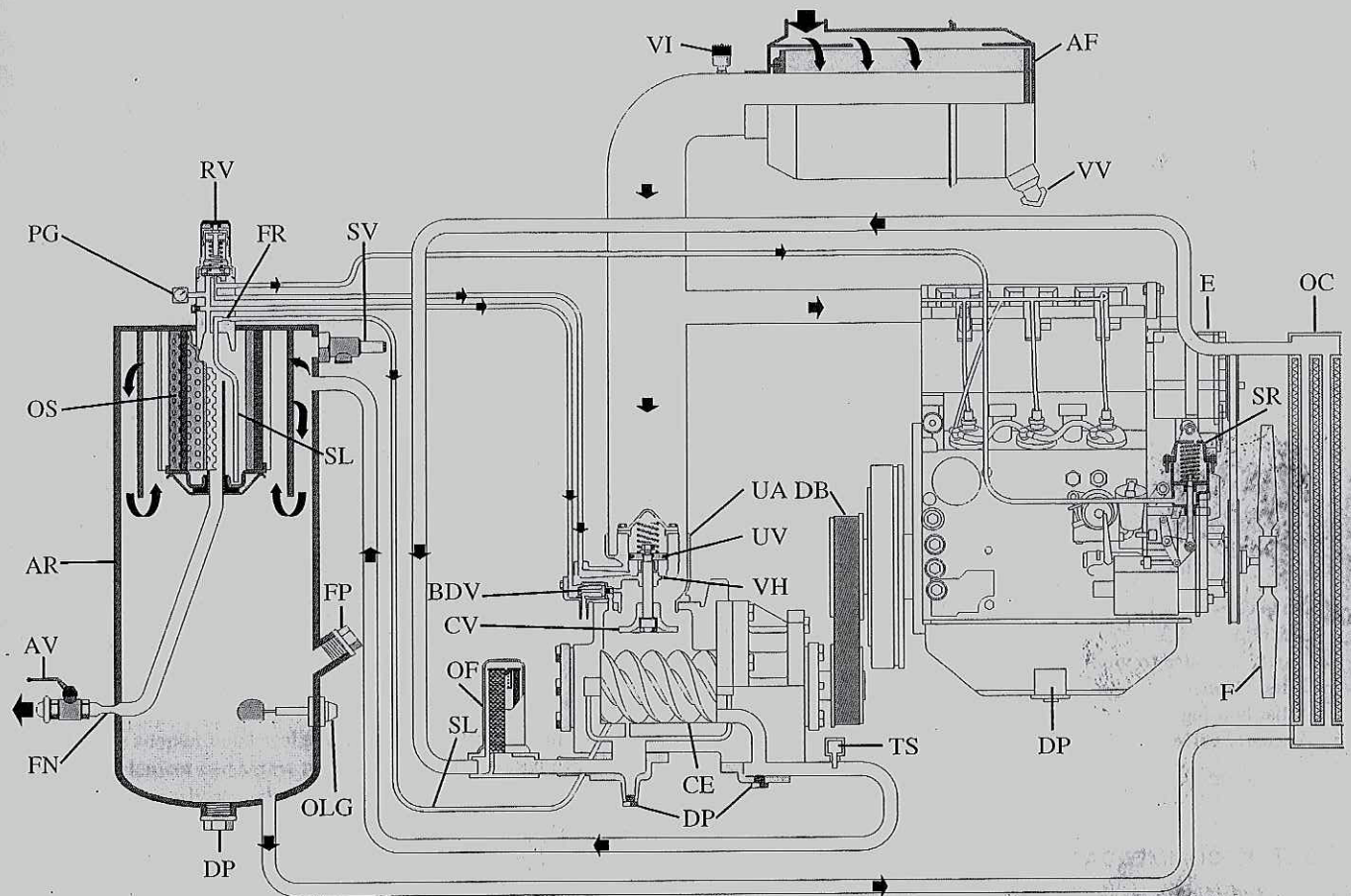

Fig. 5.1

The working pressure is determined by the tension of the spring in the regulating valve (RV). This tension can be increased to raise the pressure and decreased to lower it by turning the adjusting wheel clockwise and anti-clockwise respectively.

To adjust the normal working pressure, proceed as follows:

1. Start and warm up the engine (see section 3.3).
2. With the outlet valves (AV) closed, pull out the knob, adjust the regulating valve (RV) until a pressure of 8.5 bar(e) is reached.
3. Check the minimum speed of the engine. Adjust minimum speed stop screw if necessary.
4. Open an outlet valve (AV) just enough to let the engine (E) run at maximum speed. The working pressure must be 7 bar(e); adjust if necessary with regulating valve (RV).
5. Check the engine maximum speed. Adjust the maximum speed by means of adjusting eccentric nut on top of speed regulator (SR).
6. Close the outlet valves (AV), check that the pressure is between 8.3 and 8.7 bar(e). Lock the regulating valve (RV) by pushing the knob down.

5.2 AIR FILTER ENGINE/COMPRESSOR

5.2.1 MAIN PARTS

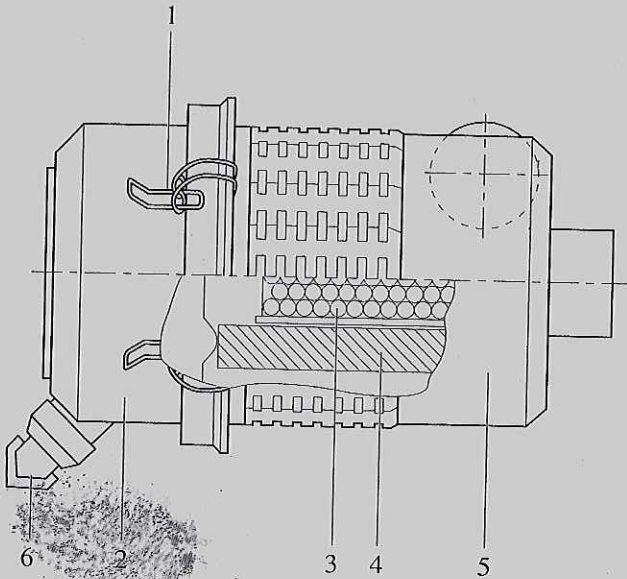

Fig. 5.2 Air filter

- 1 Snap clips
- 2 Dust trap
- 3 Safety cartridge (option)
- 4 Filter element
- 5 Filter housing
- 6 Vacuator valve

5.2.2 RECOMMENDATIONS



The Atlas Copco air filters are specially designed for the application. The use of non-genuine air filters may lead to severe damage of engine and/or compressor element.

Never run the compressor without air filter element.

New elements must also be inspected for tears or punctures before installation.

Discard the element (4) when damaged.

In heavy duty applications it is recommended to install a safety cartridge which can be ordered with part no.: 2914 9309 00

A dirty safety cartridge (3) is an indication of a mal-functioning air filter element. Replace the element and the safety cartridge in this case.

The safety cartridge cannot be cleaned.

5.2.3 CLEANING THE DUST TRAP

To remove dust from the dust trap pinch the vacuator valve (6) several times.

5.2.4 REPLACING THE AIR FILTER ELEMENT

1. Release the snap clips (1) and remove the dust trap (2). Clean the trap.
2. Remove the element (4) from the housing (5).
3. Reassemble in reverse order of dismantling.
4. Inspect and tighten all air intake connections.
5. Reset the vacuum indicator (Fig. 5.3).

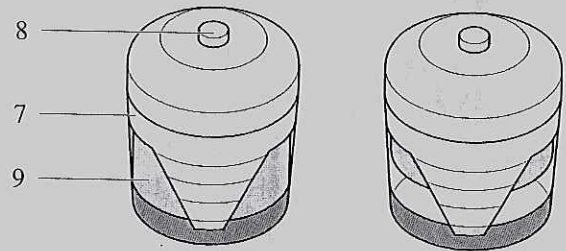

Fig. 5.3 Vacuum indicator

- 7 Air filter contamination indicator
- 8 Reset button
- 9 Yellow indicator

5.3 AIR RECEIVER

The air receiver is tested according to official standards. Regularly have inspections carried out in conformity with local regulations.

5.4 SAFETY VALVE



All adjustments or repairs are to be done by an authorized representative of the valve supplier.

Following checks must be carried out:

- a check of the opening of the lifting gear, twice a year. This can be done by screwing the cap of the valve anti-clockwise.
- a check of the set pressure once a year according to the local regulations. This check cannot be done on the machine and must be carried out on a proper test bench.

5.5 FUEL SYSTEM

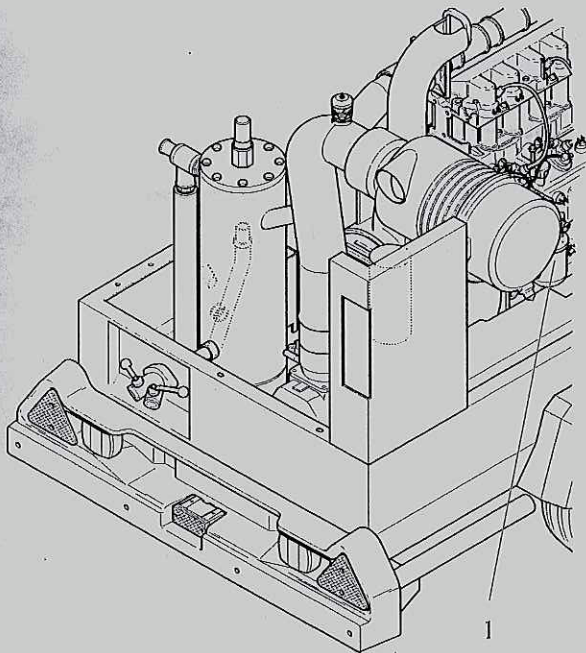

Fig. 5.4 Fuel filter

Replacing the filter element

1. Unscrew the filter element (1) from the adapter head.
2. Clean the adapter head sealing surface. Lightly oil the gasket of the new element and screw the latter onto the header until the gasket is properly seated, then tighten with both hands.
3. Check for fuel leaks once the engine has been restarted.

5.6 BRAKE (= OPTION) ADJUSTMENT



Before jacking up the compressor, connect it to a towing vehicle or attach a weight of minimum 50 kg to the towbar.

5.6.1 BRAKE SHOE ADJUSTMENT

Check the thickness of the brake lining. Remove both black plastic plugs (5), one on each wheel. When the brake lining has been worn to a thickness of 1 mm or less, the brake shoes have to be replaced. After inspection and/or replacement re-insert both plugs.

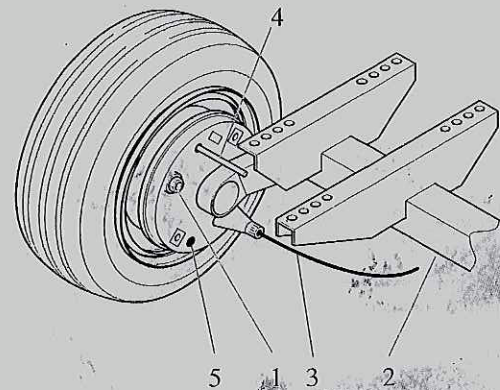

Fig. 5.5 Brake shoe adjustment

- 1 Adjusting bolt
- 2 Axle
- 3 Brake cable
- 4 Pin \varnothing 4 mm
- 5 Plug

Brake shoe adjustment re-establishes the brake lining-to-drum clearance and compensates for lining wear.

Lift and support the compressor. Make sure that all brakes are off (overrunbrake and hand brake lever). The brake cables must be free from tension. Lock the swivel cams of the wheel brake from the outside by means of a pin \varnothing 4 mm (4) through the hole as shown in Fig. 5.5.

Turn the adjusting bolt (1) clockwise with a wrench till the wheel locks up. Center the brake shoes by actuating the parking brake several times.

Turn the adjusting bolt anti-clockwise until the wheel is running free in direction of travel (approx. 1 full turn of the adjusting bolt).

Check the position of the equalizer (Fig. 5.7, 6) with the parking brake actuated.

Perpendicular position of equalizer = identical clearance of wheel brakes.

Re-adjust the brake shoes, if necessary.

To test, slightly apply the parking brake and check identical brake torque on left and right side.

Remove locking pin (4). Remove clearance from brake cables.

Check all lock nuts (Fig. 5.7, 2).

5.6.2 TEST PROCEDURE OF BRAKE CABLE ADJUSTMENT

1. Check if the towing eye rod of the overrun brake mechanism is in the outmost position.
2. Check if the adjustable towbar (= option) is in the actual towing position.
3. Apply the hand brake lever.
4. Push the compressor a few centimeters backwards so that the brake lever is automatically pulled further up.
5. Check the position of the arrow marking "1" at the catch lock in combination with the arrow marking "2" at the toothed sector, according to Fig. 5.6 A,B,C,D.

5.6.3 BRAKE CABLE ADJUSTMENT

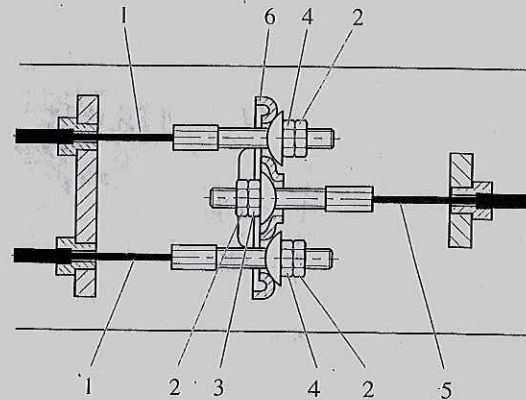

Fig. 5.7 Brake cable arrangement

- 1 Brake cable
- 2 Lock nut
- 3 Adjusting nut
- 4 Brake cable nut
- 5 Main brake cable
- 6 Equalizer

1. With the towing eye pulled out in the outmost position and the hand brake lever in the downward position (Fig. 5.8), loosen the lock nuts (Fig. 5.7, 2). Turn adjusting nut and brake cable nuts (Fig. 5.7, 4) clockwise until there is no slack in the brake mechanism.

The equalizer (Fig. 5.7, 6) must remain perpendicular to main brake cable (Fig. 5.7, 5).

2. Apply the hand brake lever several times and repeat the adjustment. Tighten the nuts with their lock nuts (Fig. 5.7, 2). Remove the jack and the blocks.
3. Road test the compressor and brake several times. Check brake shoe and brake cable adjustment and if necessary adjust.

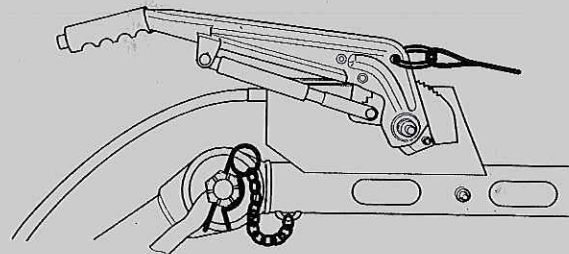
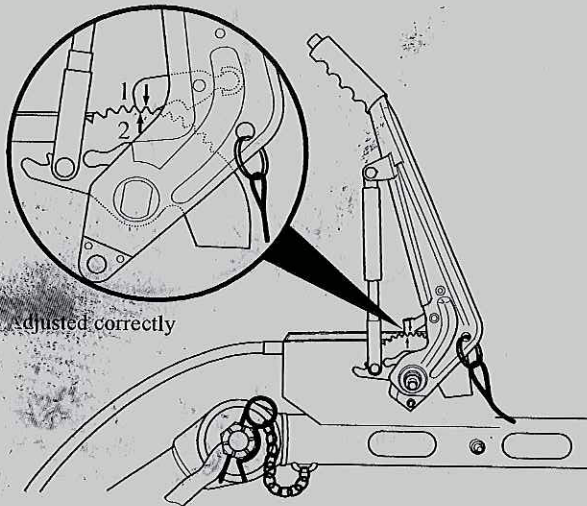
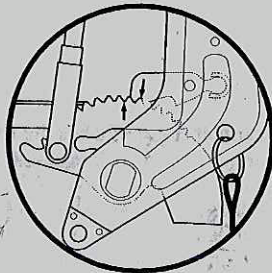

Fig. 5.8 Hand brake lever downward - brake not operated



A. Adjusted correctly



B. Acceptable

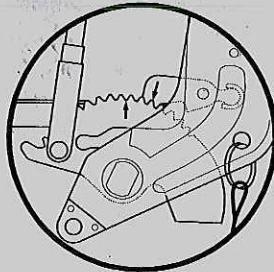

C. Too loose;
adjust brake cables
(Section 5.6.3)

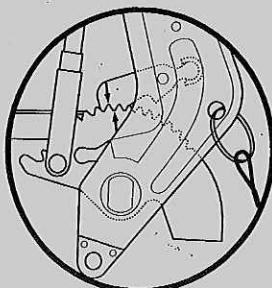

D. Too tight;
adjust brake cables
(Section 5.6.3)

Fig. 5.6 Correct and wrong position of markings

5.7 DRIVE BELT



Never retense or reuse the drive belt between engine and compressor.
Consult Atlas Copco for replacement of drive belt.

6. PROBLEM SOLVING

It is assumed that the engine is in good condition and that there is adequate fuel flow to the filter and injection equipment.



An electrical fault must be traced by an electrician.

Make sure that the wires are not damaged and that they are clamped tight to their terminals.

6.1 ALTERNATOR PRECAUTIONS

1. Never reverse the polarity of the battery or the alternator.
2. Never break any alternator or battery connections while the engine is running.
3. When recharging the battery, disconnect it from the alternator. Before using booster cables to start the engine, be sure of the polarity and connect the batteries correctly.
4. Never operate the engine without the main or voltage sensing cables connected in the circuit.

Problem	Possible faults	Corrective actions
1. Lamps (H1, H2) do not light up when switching (S1) to "I" and applying lamp test.	<ol style="list-style-type: none"> a. Discharged or defective battery. b. Loose battery cable(s) or oxidised terminals. c. Loose connection or damaged wiring. d. Contact switch (S1) defective. e. Circuit breaker (F1) defective. 	<ol style="list-style-type: none"> a. Check electrolyte level and charge battery. If no cells are shorted and battery is discharged, trace cause and correct. b. Check and correct if necessary. c. Check wiring and connections; correct if necessary. d. With (S1) switched in "I", check voltage between earth and respectively each of the terminals of (S1). Voltage must register at each of the terminals; if not, replace (S1). e. Replace circuit breaker.
2. General alarm lamp (H2) does not light up when switching (S1) to „I“; lamp (H1) lights up when applying lamp test.	<ol style="list-style-type: none"> a. Lamp (H2) blown. b. Alternator (A)/regulator defective. 	<ol style="list-style-type: none"> a. Replace lamp. b. Disconnect the wire from alternator terminal D+ and connect it to terminal D-. If (H1) lights up, replace the alternator; if not, test (S1); see remedy 1d.
3. Temperature alarm lamp (H1) does not light up when switching (S1) to „I“ and applying lamp test.	<ol style="list-style-type: none"> a. Lamp (H1) blown b. See fault 1d. 	<ol style="list-style-type: none"> a. Replace lamp. b. See 1d.
4. Starter motor (S) does not crank engine (E) after switching startbutton (S1) to "I".	<ol style="list-style-type: none"> a. Low battery output. b. Contact switch (S1) defective. c. Alternator output relay (K4) defective. d. Starter solenoid (K0) or starter motor defective. 	<ol style="list-style-type: none"> a. See remedy 1a. b. With (S1) in "I", check voltage between earth and respectively each of the terminals of (S1). Voltage must register at each of the terminals; if not, replace (S1). c. Replace (K4). d. Check start solenoid (K0). Have starter motor repaired.

Problem	Possible faults	Corrective actions
5. Starter motor cranks engine when switching start button (S1) to "Ⓡ", but engine does not fire.	<ul style="list-style-type: none"> a. Contact switch (S1) defective. b. Fuel solenoid (Y1) defective. c. Low battery output. 	<ul style="list-style-type: none"> a. See remedy 1d. b. Check solenoid and its valve, correct or replace if necessary. c. See 1a.
6. Engine fires, but general alarm lamp (H2) remains alight; engine stops when releasing start button (S1).	<ul style="list-style-type: none"> a. Alternator drive belt broken or slipping. b. Alternator (A)/regulator defective. 	<ul style="list-style-type: none"> a. Check and correct if necessary. b. Have assembly repaired.
7. Engine is running, but shuts down immediately after (S1) has been released.	<ul style="list-style-type: none"> a. Contact switch (S1) released too soon. b. Insufficient engine oil pressure. c. Fuel tank contains insufficient fuel. d. Engine oil pressure shutdown switch (S3), engine temperature switch (S2) or compressor temperature switch (S5) defective. 	<ul style="list-style-type: none"> a. Release button after engine oil pressure has built up above the minimum allowed value. b. Stop at once, consult the Engine Operation Manual. c. Fill fuel tank. d. Remove and test switches. Replace if out of order.
8. General alarm lamp (H2) remains alight for over 5 seconds after starting.	<ul style="list-style-type: none"> a. Insufficient engine oil pressure or too high engine oil temperature. b. Engine oil pressure switch (S3), or compressor temperature switch (S5) defective. c. Relay (K1) defective. 	<ul style="list-style-type: none"> a. Stop at once, consult Engine Operation Manual. b. Stop at once, test switches, replace as necessary. c. Replace (K1).
9. Hourmeter (P1) does not count running time.	<ul style="list-style-type: none"> a. Hourmeter (P1) defective. 	<ul style="list-style-type: none"> a. Replace.
10. Compressor does not unload and engine keeps running at maximum speed when closing the air outlet valves; safety valve blows.	<ul style="list-style-type: none"> a. Air leaks in regulating system. b. Regulating valve (RV) incorrectly set or defective. c. Unloading valve (UV) or its actuating piston stuck. 	<ul style="list-style-type: none"> a. Check and repair. b. Adjust or repair regulating valve; see section 5.1. c. Repair unloading valve assembly.
11. Compressor capacity or pressure below normal.	<ul style="list-style-type: none"> a. Air consumption exceeds capacity of compressor. b. Choked air filter elements (AF). c. Unloading valve (UV) not completely open. d. Engine does not run at max. speed. e. Oil separator element (OS) clogged. 	<ul style="list-style-type: none"> a. Check equipment connected. b. Replace air filter element (AF). c. Speed regulation cable maladjusted; see section 5.1 d. Check the maximum speed, service the fuel filter. e. Have element removed and inspected by an Atlas Copco Service representative.
12. No air output	<ul style="list-style-type: none"> a. Drive belt broken 	<ul style="list-style-type: none"> a. See section 5.7

Problem	Possible faults	Corrective actions
13. Working pressure rises during operation and causes safety valve to blow.	<ul style="list-style-type: none"> a. See faults 10. b. Safety valve (SV) opens too soon. 	<ul style="list-style-type: none"> a. See remedies 10. b. Have safety valve adjusted; consult Atlas Copco.
14. Excessive compressor oil consumption. Oil mist being discharged from air outlet valve(s).	<ul style="list-style-type: none"> a. Restrictor in oil scavenging line (SL) clogged. b. Oil separator element (OS) defective. c. Oil level too high. 	<ul style="list-style-type: none"> a. Dismount, clean and refit restrictor. b. Replace element. c. Check for overfilling. Release pressure and drain oil to correct level.
15. Compressor shuts down through a shutdown switch.	<ul style="list-style-type: none"> a. Alternator V-belt broken or slipping. b. Compressor overheating. c. Engine oil pressure too low. d. Engine temperature too high. 	<ul style="list-style-type: none"> a. Re-tense or replace V-belt. b. See condition 16. c. Check lubricating system. d. Check engine oil system; see Engine Operation Manual.
16. Air and oil mist expelled from air filter after stopping.	<ul style="list-style-type: none"> a. Unloader valve (UV) defective. b. Wrong oil type (without foam-retarding additives). 	<ul style="list-style-type: none"> a. Repair valve. b. Consult Atlas Copco.
17. Compressor overheating.	<ul style="list-style-type: none"> a. Insufficient compressor cooling. b. Oil cooler (OC) clogged externally. c. Oil system clogged internally. d. Oil level too low. e. Cooling fan (F) defective. f. Oil separator element (OS) clogged. g. Oil filter (OF) clogged. 	<ul style="list-style-type: none"> a. Relocate compressor. b. Clean cooler; see section 4.6. c. Consult Atlas Copco. d. See section 4.4. e. Replace fan. f. Replace oil separator. g. Replace oil filter.

7. AVAILABLE OPTIONS

The XAS66 Dd can be delivered with following options:

Vessel type:	EURO ASME
Towbar:	Adjustable with brakes Adjustable without brakes Fixed with brakes Fixed without brakes Support (without undercarriage)
Towing eyes:	Atlas Copco DIN Ball Italian GB 50 mm NATO
Towbar support:	Leg Jockey wheel
Road signalisation:	Full Semi Semi prime
Air quality equipment:	Aftercooler + water separator Aftercooler + water separator + lubricator Aftercooler + water separator +PD filter Aftercooler + water separator +PD/QD filters Aftercooler + water separator +PD filter + lubricator Aftercooler + water separator +PD/QD filters + lubricator Reheater Simplified reheater Lubricator
Generator:	110 V (Type DdG) 230/400 V (Type DdG IT)
Tool box ¹⁾ :	Single Twin
Safety:	Wheel chocks Safety cartridge Spark arrestor Refinery equipment Exhaust pipe
Cold start:	-20°C kit
Customer colour	single double triple

¹⁾ if no generator installed

8. INSTALLATION RECOMMENDATIONS FOR FRAME SUPPORT

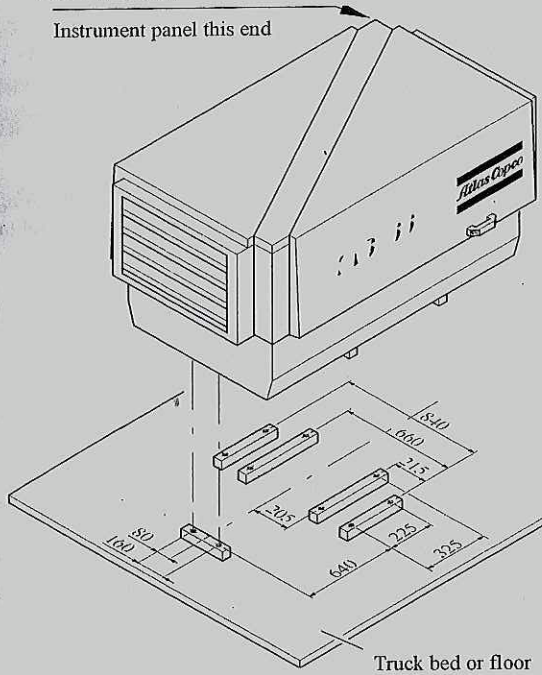

Fig. 8.1 Installing the compressor on the truck floor

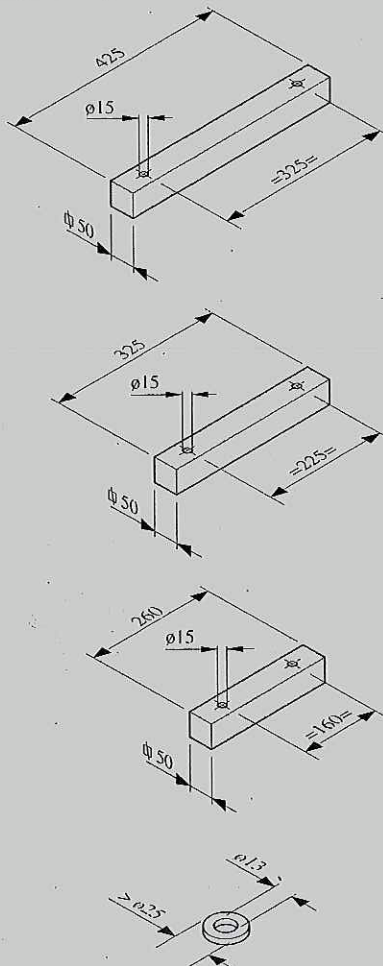



Fig. 8.2 Parts required

 For support mounted portable compressors we recommend the use of Atlas Copco option „Support mounted“. If for technical reasons, this option can not be used, the following recommendations should be followed ensuring a safe installation:

Remove towbar, shaft, bumper and mudguards (if installed).

- Determine the position of the compressor on the bed or floor of the truck

 When doing so, take into account:

- weight of the compressor
- dimensions of the compressor
- position of the instrument panel
- position of the engine exhaust outlet
- position of the compressed air outlet valves
- opening and closing of the compressor doors.

Drill holes with a diameter of 15 mm in the bed or floor of the truck, according the pattern in Fig. 8.1 (General tolerance: ± 1 mm).

Prepare the required supports according Fig. 8.2.

Use only materials and parts of sufficient strength and stability.

- 2 blocks of 50 mm x 50 mm x 425 mm (2 holes with a diameter of 15 mm)

- 2 blocks of 50 mm x 50 mm x 325 mm (2 holes with a diameter of 15 mm)

- 1 block of 50 mm x 50 mm x 260 mm (2 holes with a diameter of 15 mm)

- 10 washers for M12

- 10 bolts of M12 (strength at least 8.8), ? mm long

Measure the thickness of the truck bed or floor in order to determine how long the bolts must be.



Make sure that the bolts do not protrude from the truck bed or floor by more than 75 mm (check, see Fig. 8.3). Too long bolts may puncture the fuel tank.

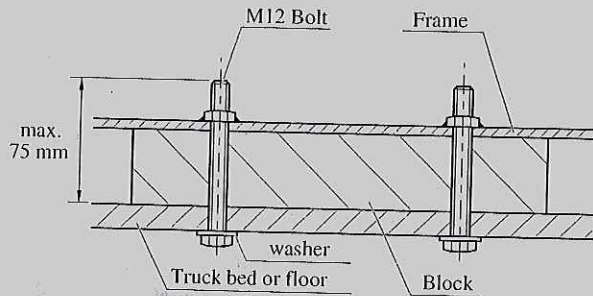

Fig. 8.3 Cross section

Put blocks of 50 x 50 mm on the bed or floor of the truck according to the pattern shown in Fig. 8.1.

Slowly lower the compressor onto the blocks, making sure these are not displaced.

Tighten the M12 bolts (correct length!), from the lower side, into the nuts welded to the interior of the compressor bottom.

(For the recommended tightening torques of the bolts, see section 9 'Technical Specifications').

Once again make sure that the bolts used are sufficiently long to correctly fasten the compressor without contacting the fuel tank.

9. TECHNICAL SPECIFICATIONS

9.1 TORQUE VALUES

9.1.1 FOR GENERAL APPLICATIONS

The following tables list the recommended torques applied for general applications at assembly of the compressor.

For hexagon screws and nuts with strength grade 8.8

Thread size	M6	M8	M10	M12	M14	M16
Nm	9	23	46	80	125	205

For hexagon screws and nuts with strength grade 12.9

Thread size	M6	M8	M10	M12	M14	M16
Nm	15	39	78	135	210	345

9.1.2 FOR IMPORTANT ASSEMBLIES

Assemblies	Unit	Torque value	
Wheel nuts	Nm	80	+10/-0
Bolts, axle/beams	Nm	80	+/- 10
Bolts, towbar/axle	Nm	80	+/- 10
Bolts, towbar/bottom	Nm	80	+/- 10
Bolts, towing eye/towbar	Nm	80	+/- 10
Bolts, lifting eye/flywheel housing	Nm	205	+ 20
Bolts, engine/drive housing (M12)	Nm	80	+/- 10
Bolts, engine/drive housing (M14)	Nm	125	+/- 10
Bolts, compressor element/drive housing	Nm	80	+/- 5
Safety switches	Nm	35	+/- 5
Joins adjustable towbar (M24)	Nm	275	+/- 25
(M32)	Nm	375	+/- 25

Note:

Secure the tank cap and drain cock of the fuel tank handtight.

9.2 SETTINGS OF SHUTDOWN SWITCHES AND SAFETY VALVES

Designation	Unit	Value
Engine oil pressure	bar(e)	1.2
Engine oil temperature	°C	127 - 133
Compressor temperature	°C	116 - 120
Safety valve opening pressure		
EC type	bar(e)	10.5
ASME type	psi	135

9.3 COMPRESSOR/ENGINE SPECIFICATIONS

Compressor type

Designation	Unit	XAS66 Dd
Reference conditions		
1. Absolute inlet pressure	bar	1
2. Relative air humidity	%	0
3. Air inlet temperature	°C	20
4. Nominal effective working pressure	bar	7

The inlet conditions are specified at the air inlet grating outside the canopy

Limitations

1. Minimum effective receiver pressure	bar	2.9
2. Maximum effective receiver pressure	bar	8.5
3. Maximum ambient temperature	°C	45
4. Minimum starting temperature	°C	-15
5. Altitude capability (see separate curve below)	m	

Altitude unit performance curve
Max. allowable working pressure as a function altitude and ambient temperature.

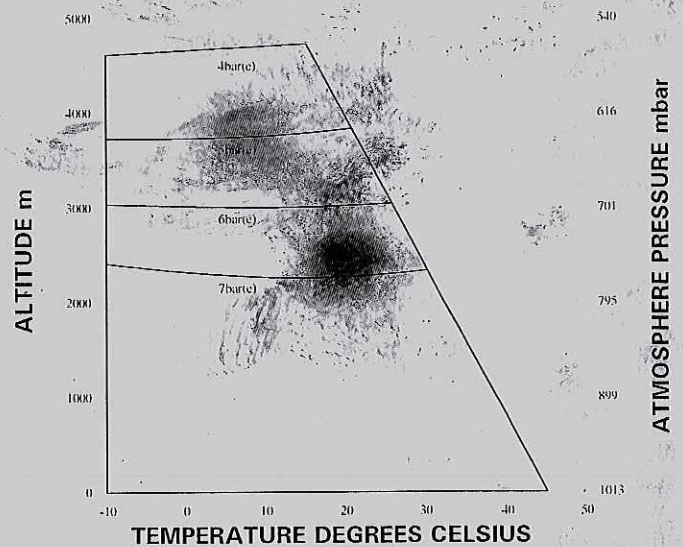

Performance data 1)

1. Engine shaft speed, normal and maximum	r/min	2400
2. Engine shaft speed, compressor unloaded	r/min	1600
3. Free air delivery 2)	l/s	61
4. Compressed air temperature at outlet valves	°C	89
5. Noise level		
- Sound pressure level (LP), measured according to EPA with a tolerance of +/- 3 dB(A) under free field conditions at 7 m distance	dB(A)	72
- Sound power level (LW) complies with 84/532/533/EEC and 85/406/EEC limits	dB(A)	100