

Atlas Copco Instruction Manual

Air Compressor 300 cfm

plant #: 01 03 016

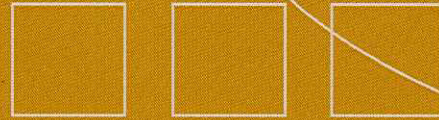

Instruction Manual
for Portable Compressors
English

XA(S) 137 DD - XA(S) 300 DD7
XA(S) 137 DDG - XA(S) 300 DD7G
XAHS 107 DD - XAHS 250 DD7

Engine Deutz
BF4M2011



19 SIRIUS ROAD,
LANE COVE, N.S.W. 2066

**Instruction Manual
for Portable Compressors**

XA(S) 137 DD - XA(S) 300 DD7

XA(S) 137 DDG - XA(S) 300 DD7G

XAHS 107 DD - XAHS 250 DD7

Printed matter N°
1092 0374 44

04/2008



ATLAS COPCO - PORTABLE AIR DIVISION
www.atlascopco.com

Warranty and Liability Limitation

Use only authorized parts.

Any damage or malfunction caused by the use of unauthorized parts is not covered by Warranty or Product Liability.

The manufacturer does not accept any liability for any damage arising for modifications, additions or conversions made without the manufacturer's approval in writing.

While every effort has been made to ensure that the information in this manual is correct, Atlas Copco does not assume responsibility for possible errors.

Copyright 2008, Atlas Copco Airpower n.v., Antwerp, Belgium.

Any unauthorized use or copying of the contents or any part thereof is prohibited.

This applies in particular to trademarks, model denominations, part numbers and drawings.

Atlas Copco

Preface

Please read the following instructions carefully before starting to use your compressor.

It is a solid, safe and reliable machine, built according to the latest technology. Follow the instructions in this booklet and we guarantee you years of troublefree operation.

Always keep the manual available near the machine.

In all correspondence always mention the compressor type and serial number, shown on the data plate.

The company reserves the right to make changes without prior notice.

Table of contents

1	Safety precautions for portable compressors with generator	5	4.2	Starting/Stopping	28
1.1	Introduction	5	4.2.1	Before starting	28
1.2	General safety precautions	6	4.2.2	Control panel (with cold start; option)...	28
1.3	Safety during transport and installation	7	4.2.3	Control panel (without cold start)	30
1.4	Safety during use and operation	7	4.2.4	Generator function (XAS 137 DDG - XA(S) 300 DD7G)	32
1.5	Safety during maintenance and repair	9	4.2.5	During operation	33
1.6	Tool applications safety	10	4.2.6	Stopping procedure	33
1.7	Specific safety precautions	11	5	Maintenance	34
2	Leading particulars	12	5.1	Use of service paks	34
2.1	Description of safety pictograms used in this manual	12	5.2	Preventive maintenance schedule for the compressor	34
2.2	General description	12	5.3	Lubrication oils	36
3	Main Parts	14	5.4	Oil level check	38
3.1	Compressor regulating system	16	5.4.1	Check engine oil level	38
3.1.1	Overview (Load condition)	16	5.4.2	Check compressor oil level	38
3.1.2	Air flow	17	5.5	Oil and oil filter change	39
3.1.3	Oil system	17	5.5.1	Engine oil and oil filter change	39
3.1.4	Continuous regulating system	18	5.5.2	Compressor oil and oil filter change	39
3.2	Electrical system	20	5.6	Cleaning coolers	40
3.2.1	Description	23	5.7	Battery care	40
3.3	Markings and information labels	24	5.7.1	Electrolyte	40
4	Operating instructions	25	5.7.2	Activating a dry-charged battery	41
4.1	Parking, towing and lifting instructions	25	5.7.3	Recharging a battery	41
4.1.1	Parking instructions	25	5.7.4	Battery maintenance	41
4.1.2	Towing instructions	26	5.8	Storage	41
4.1.3	Height adjustment	27	5.9	Service paks	41
4.1.4	Lifting instructions	27	5.10	Service kits	41
			5.11	Compressor element overhaul	41
			5.12	Liability	41

CALIFORNIA

Proposition 65 Warning

Diesel engine exhaust and some of its constituents are known to the State of California to cause cancer, birth defects, and other reproductive harm.

6	Adjustments and servicing procedures ..	42	9.3.5	Design data for generator	64
6.1	Adjustment of the continuous regulating system	42	10	Data plate	65
6.2	Air filter engine/compressor	44	11	Disposal	66
6.2.1	Servicing	44	11.1	General	66
6.2.2	Main parts	44	11.2	Disposal of materials	66
6.2.3	Cleaning the dust trap	44	12	Maintenance Log	67
6.2.4	Cleaning instructions filter element	44			
6.2.5	Replacing the air filter element	45			
6.3	Air receiver	46			
6.4	Safety valve	46			
6.5	Fuel system	46			
6.6	Brake (= option) adjustment	47			
6.7	Brake shoe adjustment	47			
6.7.1	Test procedure of brake cable adjustment	48			
6.7.2	Brake cable adjustment	49			
7	Problem solving	50			
8	Available options	53			
9	Technical specifications	54			
9.1	Torque values	54			
9.1.1	For general applications	54			
9.1.2	For important assemblies	54			
9.2	Settings of shutdown switches and safety valves	55			
9.3	Compressor/Engine/Generator specifications	56			
9.3.1	Reference conditions	56			
9.3.2	Limitations	57			
9.3.3	Performance data	59			
9.3.4	Design data	62			

Safety precautions for portable compressors with generator



To be read attentively and acted accordingly before towing, lifting, operating, performing maintenance or repairing the unit.

INTRODUCTION

The policy of Atlas Copco is to provide the users of their equipment with safe, reliable and efficient products. Factors taken into account are among others:

- the intended and predictable future use of the products, and the environments in which they are expected to operate,
- applicable rules, codes and regulations,
- the expected useful product life, assuming proper service and maintenance,
- providing the manual with up-to-date information.

Before handling any product, take time to read the relevant instruction manual. Besides giving detailed operating instructions, it also gives specific information about safety, preventive maintenance, etc.

Keep the manual always at the unit location, easy accessible to the operating personnel.

See also the safety precautions of the engine and possible other equipment, which are separately sent along or are mentioned on the equipment or parts of the unit.

These safety precautions are general and some statements will therefore not always apply to a particular unit.

Only people that have the right skills should be allowed to operate, adjust, perform maintenance or repair on Atlas Copco equipment.

It is the responsibility of management to appoint operators with the appropriate training and skill for each category of job.

Skill level 1: Operator

An operator is trained in all aspects of operating the unit with the push-buttons, and is trained to know the safety aspects.

Skill level 2: Mechanical technician

A mechanical technician is trained to operate the unit the same as the operator. In addition, the mechanical technician is also trained to perform maintenance and repair, as described in the instruction manual, and is allowed to change settings of the control and safety system. A mechanical technician does not work on live electrical components.

Skill level 3: Electrical technician

An electrical technician is trained and has the same qualifications as both the operator and the mechanical technician. In addition, the electrical technician may carry out electrical repairs within the various enclosures of the unit. This includes work on live electrical components.

Skill level 4: Specialist from the manufacturer

This is a skilled specialist sent by the manufacturer or its agent to perform complex repairs or modifications to the equipment.

In general it is recommended that not more than two people operate the unit, more operators could lead to unsafe operating conditions.

Take necessary steps to keep unauthorized persons away from the unit and eliminate all possible sources of danger at the unit.

When handling, operating, overhauling and/or performing maintenance or repair on Atlas Copco equipment, the mechanics are expected to use safe engineering practices and to observe all relevant local safety requirements and ordinances. The following list is a reminder of special safety directives and precautions mainly applicable to Atlas Copco equipment.

These safety precautions apply to machinery processing or consuming air. Processing of any other gas requires additional safety precautions typical to the application and are not included herein.

Neglecting the safety precautions may endanger people as well as environment and machinery:

- endanger people due to electrical, mechanical or chemical influences,
- endanger the environment due to leakage of oil, solvents or other substances,
- endanger the machinery due to function failures.

All responsibility for any damage or injury resulting from neglecting these precautions or by non-observance of ordinary caution and due care required in handling, operating, maintenance or repair, also if not expressly mentioned in this instruction manual, is disclaimed by Atlas Copco.

The manufacturer does not accept any liability for any damage arising from the use of non-original parts and for modifications, additions or conversions made without the manufacturer's approval in writing.

If any statement in this manual does not comply with local legislation, the stricter of the two shall be applied.

Statements in these safety precautions should not be interpreted as suggestions, recommendations or inducements that it should be used in violation of any applicable laws or regulations.

GENERAL SAFETY PRECAUTIONS

- 1 The owner is responsible for maintaining the unit in a safe operating condition. Unit parts and accessories must be replaced if missing or unsuitable for safe operation.
- 2 The supervisor, or the responsible person, shall at all times make sure that all instructions regarding machinery and equipment operation and maintenance are strictly followed and that the machines with all accessories and safety devices, as well as the consuming devices, are in good repair, free of abnormal wear or abuse, and are not tampered with.
- 3 Whenever there is an indication or any suspicion that an internal part of a machine is overheated, the machine shall be stopped but no inspection covers shall be opened before sufficient cooling time has elapsed; this to avoid the risk of spontaneous ignition of oil vapour when air is admitted.

- 4 Normal ratings (pressures, temperatures, speeds, etc.) shall be durably marked.
- 5 Operate the unit only for the intended purpose and within its rated limits (pressure, temperature, speeds, etc.).
- 6 The machinery and equipment shall be kept clean, i.e. as free as possible from oil, dust or other deposits.
- 7 To prevent an increase in working temperature, inspect and clean heat transfer surfaces (cooler fins, intercoolers, water jackets, etc.) regularly. See the maintenance schedule. See the **Preventive maintenance schedule for the compressor**.
- 8 All regulating and safety devices shall be maintained with due care to ensure that they function properly. They may not be put out of action.
- 9 Care shall be taken to avoid damage to safety valves and other pressure-relief devices, especially to avoid plugging by paint, oil coke or dirt accumulation, which could interfere with the functioning of the device.
- 10 Pressure and temperature gauges shall be checked regularly with regard to their accuracy. They shall be replaced whenever outside acceptable tolerances.
- 11 Safety devices shall be tested as described in the maintenance schedule of the instruction manual to determine that they are in good operating condition. See the **Preventive maintenance schedule for the compressor**.
- 12 Mind the markings and information labels on the unit.
- 13 In the event the safety labels are damaged or destroyed, they must be replaced to ensure operator safety.
- 14 Keep the work area neat. Lack of order will increase the risk of accidents.
- 15 When working on the unit, wear safety clothing. Depending on the kind of activities these are: safety glasses, ear protection, safety helmet (including visor), safety gloves, protective clothing, safety shoes. Do not wear the hair long and loose (protect long hair with a hairnet), or wear loose clothing or jewelry.
- 16 Take precautions against fire. Handle fuel, oil and anti-freeze with care because they are inflammable substances. Do not smoke or approach with naked flame when handling such substances. Keep a fire-extinguisher in the vicinity.
- 17 **Portable compressors with generator (with earthing pin):**
Earth the generator as well as the load properly.
- 18 **Portable compressors with generator IT:**
Note: This generator is built to supply a sheer alternating current IT network.
Earth the load properly.

SAFETY DURING TRANSPORT AND INSTALLATION

To lift a unit, all loose or pivoting parts, e.g. doors and towbar, shall first be securely fastened.

Do not attach cables, chains or ropes directly to the lifting eye; apply a crane hook or lifting shackle meeting local safety regulations. Never allow sharp bends in lifting cables, chains or ropes.

Helicopter lifting is not allowed.

It is strictly forbidden to dwell or stay in the risk zone under a lifted load. Never lift the unit over people or residential areas. Lifting acceleration and retardation shall be kept within safe limits.

1 Before towing the unit:

- ascertain that the pressure vessel(s) is (are) depressurized,
- check the towbar, the brake system and the towing eye. Also check the coupling of the towing vehicle,
- check the towing and brake capability of the towing vehicle,
- check that the towbar, jockey wheel or stand leg is safely locked in the raised position,
- ascertain that the towing eye can swivel freely on the hook,
- check that the wheels are secure and that the tyres are in good condition and inflated correctly,
- connect the signalisation cable, check all lights and connect the pneumatic brake couplers,
- attach the safety break-away cable or safety chain to the towing vehicle,
- remove wheel chocks, if applied, and disengage the parking brake.

- 2 To tow a unit use a towing vehicle of ample capacity. Refer to the documentation of the towing vehicle.
- 3 If the unit is to be backed up by the towing vehicle, disengage the overrun brake mechanism (if it is not an automatic mechanism).
- 4 Never exceed the maximum towing speed of the unit (mind the local regulations).
- 5 Place the unit on level ground and apply the parking brake before disconnecting the unit from the towing vehicle. Unclip the safety break-away cable or safety chain. If the unit has no parking brake or jockey wheel, immobilize the unit by placing chocks in front of and/or behind the wheels. When the towbar can be positioned vertically, the locking device must be applied and kept in good order.
- 6 To lift heavy parts, a hoist of ample capacity, tested and approved according to local safety regulations, shall be used.
- 7 Lifting hooks, eyes, shackles, etc., shall never be bent and shall only have stress in line with their design load axis. The capacity of a lifting device diminishes when the lifting force is applied at an angle to its load axis.
- 8 For maximum safety and efficiency of the lifting apparatus all lifting members shall be applied as near to perpendicular as possible. If required, a lifting beam shall be applied between hoist and load.
- 9 Never leave a load hanging on a hoist.
- 10 A hoist has to be installed in such a way that the object will be lifted perpendicular. If that is not possible, the necessary precautions must be taken to prevent load-swinging, e.g. by using two hoists, each at approximately the same angle not exceeding 30° from the vertical.

- 11 Locate the unit away from walls. Take all precautions to ensure that hot air exhausted from the engine and driven machine cooling systems cannot be recirculated. If such hot air is taken in by the engine or driven machine cooling fan, this may cause overheating of the unit; if taken in for combustion, the engine power will be reduced.
- 12 The electrical connections shall correspond to local codes. The machines shall be earthed and protected against short circuits by fuses or circuit breakers.
- 13 Never connect the generator outlets to an installation which is also connected to a public mains.
- 14 Before connecting a load, switch off the corresponding circuit breaker, and check whether frequency, voltage, current and power factor comply with the ratings of the generator.

SAFETY DURING USE AND OPERATION

- 1 When the unit has to operate in a fire-hazardous environment, each engine exhaust has to be provided with a spark arrestor to trap incendiary sparks.
- 2 The exhaust contains carbon monoxide which is a lethal gas. When the unit is used in a confined space, conduct the engine exhaust to the outside atmosphere by a pipe of sufficient diameter; do this in such a way that no extra back pressure is created for the engine. If necessary, install an extractor. Observe any existing local regulations. Make sure that the unit has sufficient air intake for operation. If necessary, install extra air intake ducts.

- 3 When operating in a dust-laden atmosphere, place the unit so that dust is not carried towards it by the wind. Operation in clean surroundings considerably extends the intervals for cleaning the air intake filters and the cores of the coolers.
- 4 Close the compressor air outlet valve before connecting or disconnecting a hose. Ascertain that a hose is fully depressurized before disconnecting it. Before blowing compressed air through a hose or air line, ensure that the open end is held securely, so that it cannot whip and cause injury.
- 5 The air line end connected to the outlet valve must be safeguarded with a safety cable, attached next to the valve.
- 6 No external force may be exerted on the air outlet valves, e.g. by pulling on hoses or by installing auxiliary equipment directly to a valve, e.g. a water separator, a lubricator, etc. Do not step on the air outlet valves.
- 7 Never move a unit when external lines or hoses are connected to the outlet valves, to avoid damage to valves, manifold and hoses.
- 8 Do not use compressed air from any type of compressor, without taking extra measures, for breathing purposes as this may result in injury or death. For breathing air quality, the compressed air must be adequately purified according to local legislation and standards. Breathing air must always be supplied at stable, suitable pressure.
- 9 Distribution pipework and air hoses must be of correct diameter and suitable for the working pressure. Never use frayed, damaged or deteriorated hoses. Replace hoses and flexibles before the lifetime expires. Use only the correct type and size of hose end fittings and connections.
- 10 If the compressor is to be used for sand-blasting or will be connected to a common compressed-air

system, fit an appropriate non-return valve (check valve) between compressor outlet and the connected sand-blasting or compressed-air system. Observe the right mounting position/direction.

- 11 Before removing the oil filler plug, ensure that the pressure is released by opening an air outlet valve.
- 12 Never remove a filler cap of the cooling water system of a hot engine. Wait until the engine has sufficiently cooled down.
- 13 Never refill fuel while the unit is running, unless otherwise stated in the Atlas Copco Instruction Book. Keep fuel away from hot parts such as air outlet pipes or the engine exhaust. Do not smoke when fuelling. When fuelling from an automatic pump, an earthing cable should be connected to the unit to discharge static electricity. Never spill nor leave oil, fuel, coolant or cleansing agent in or around the unit.
- 14 All doors shall be shut during operation so as not to disturb the cooling air flow inside the bodywork and/or render the silencing less effective. A door should be kept open for a short period only e.g. for inspection or adjustment.
- 15 Periodically carry out maintenance works according to the maintenance schedule.
- 16 Stationary housing guards are provided on all rotating or reciprocating parts not otherwise protected and which may be hazardous to personnel. Machinery shall never be put into operation, when such guards have been removed, before the guards are securely reinstalled.
- 17 Noise, even at reasonable levels, can cause irritation and disturbance which, over a long period of time, may cause severe injuries to the nervous system of human beings.

When the sound pressure level, at any point where personnel normally has to attend, is:

- below 70 dB(A): no action needs to be taken,
 - above 70 dB(A): noise-protective devices should be provided for people continuously being present in the room,
 - below 85 dB(A): no action needs to be taken for occasional visitors staying a limited time only,
 - above 85 dB(A): room to be classified as a noise-hazardous area and an obvious warning shall be placed permanently at each entrance to alert people entering the room, for even relatively short times, about the need to wear ear protectors,
 - above 95 dB(A): the warning(s) at the entrance(s) shall be completed with the recommendation that also occasional visitors shall wear ear protectors,
 - above 105 dB(A): special ear protectors that are adequate for this noise level and the spectral composition of the noise shall be provided and a special warning to that effect shall be placed at each entrance.
- 18 Insulation or safety guards of parts the temperature of which can be in excess of 80 °C (175 °F) and which may be accidentally touched by personnel shall not be removed before the parts have cooled to room temperature.
 - 19 Never operate the unit in surroundings where there is a possibility of taking in flammable or toxic fumes.
 - 20 If the working process produces fumes, dust or vibration hazards, etc., take the necessary steps to eliminate the risk of personnel injury.
 - 21 When using compressed air or inert gas to clean down equipment, do so with caution and use the

- appropriate protection, at least safety glasses, for the operator as well as for any bystander. Do not apply compressed air or inert gas to your skin or direct an air or gas stream at people. Never use it to clean dirt from your clothes.
- 22 When washing parts in or with a cleaning solvent, provide the required ventilation and use appropriate protection such as a breathing filter, safety glasses, rubber apron and gloves, etc.
 - 23 Safety shoes should be compulsory in any workshop and if there is a risk, however small, of falling objects, wearing of a safety helmet should be included.
 - 24 If there is a risk of inhaling hazardous gases, fumes or dust, the respiratory organs must be protected and depending on the nature of the hazard, so must the eyes and skin.
 - 25 Remember that where there is visible dust, the finer, invisible particles will almost certainly be present too; but the fact that no dust can be seen is not a reliable indication that dangerous, invisible dust is not present in the air.
 - 26 Never operate the unit at pressures or speeds below or in excess of its limits as indicated in the technical specifications.
 - 27 Never operate the generator in excess of its limits as indicated in the technical specifications and avoid long no-load sequences.
 - 28 Never operate the generator in a humid atmosphere. Excessive moisture causes worsening of the generator insulation.
 - 29 Do not open electrical cabinets, cubicles or other equipment while voltage is supplied. If such cannot be avoided, e.g. for measurements, tests or adjustments, have the action carried out by a qualified electrician only, with appropriate tools, and ascertain that the required bodily protection against electrical hazards is applied.
 - 30 Never touch the power terminals during operation of the machine.
 - 31 Whenever an abnormal condition arises, e.g. excessive vibration, noise, odour, etc., switch the circuit breakers to OFF and stop the engine. Correct the faulty condition before restarting.
 - 32 Check the electric cables regularly. Damaged cables and insufficient lightening of connections may cause electric shocks. Whenever damaged wires or dangerous conditions are observed, switch the circuit breakers to OFF and stop the engine. Replace the damaged wires or correct the dangerous condition before restarting. Make sure that all electric connections are securely tightened.
 - 33 Avoid overloading the generator. The generator is provided with circuit breakers for overload protection. When a breaker has tripped, reduce the concerned load before restarting.
 - 34 If the generator is used as stand-by for the mains supply, it must not be operated without control system which automatically disconnects the generator from the mains when the mains supply is restored.
 - 35 Never remove the cover of the output terminals during operation. Before connecting or disconnecting wires, switch off the load and the circuit breakers, stop the machine and make sure that the machine cannot be started inadvertently or there is any residual voltage on the power circuit.
 - 36 Running the generator at low load for long periods will reduce the lifetime of the engine.

SAFETY DURING MAINTENANCE AND REPAIR

Maintenance, overhaul and repair work shall only be carried out by adequately trained personnel; if required, under supervision of someone qualified for the job.

- 1 Use only the correct tools for maintenance and repair work, and only tools which are in good condition.
- 2 Parts shall only be replaced by genuine Atlas Copco replacement parts.
- 3 All maintenance work, other than routine attention, shall only be undertaken when the unit is stopped. Steps shall be taken to prevent inadvertent starting. In addition, a warning sign bearing a legend such as "work in progress; do not start" shall be attached to the starting equipment.
On engine-driven units the battery shall be disconnected and removed or the terminals covered by insulating caps.
On electrically driven units the main switch shall be locked in open position and the fuses shall be taken out. A warning sign bearing a legend such as "work in progress; do not supply voltage" shall be attached to the fuse box or main switch.
- 4 Before dismantling any pressurized component, the compressor or equipment shall be effectively isolated from all sources of pressure and the entire system shall be relieved of pressure. Do not rely on non-return valves (check valves) to isolate pressure systems. In addition, a warning sign bearing a legend such as "work in progress; do not open" shall be attached to each of the outlet valves.
- 5 Prior to stripping an engine or other machine or undertaking major overhaul on it, prevent all movable parts from rolling over or moving.

- 6 Make sure that no tools, loose parts or rags are left in or on the machine. Never leave rags or loose clothing near the engine air intake.
- 7 Never use flammable solvents for cleaning (fire-risk).
- 8 Take safety precautions against toxic vapours of cleaning liquids.
- 9 Never use machine parts as a climbing aid.
- 10 Observe scrupulous cleanliness during maintenance and repair. Keep away dirt, cover the parts and exposed openings with a clean cloth, paper or tape.
- 11 Never weld on or perform any operation involving heat near the fuel or oil systems. Fuel and oil tanks must be completely purged, e.g. by steam-cleaning, before carrying out such operations. Never weld on, or in any way modify, pressure vessels. Disconnect the alternator cables during arc welding on the unit.
- 12 Support the towbar and the axle(s) securely if working underneath the unit or when removing a wheel. Do not rely on jacks.
- 13 Do not remove any of, or tamper with, the sound-damping material. Keep the material free of dirt and liquids such as fuel, oil and cleansing agents. If any sound-damping material is damaged, replace it to prevent the sound pressure level from increasing.
- 14 Use only lubricating oils and greases recommended or approved by Atlas Copco or the machine manufacturer. Ascertain that the selected lubricants comply with all applicable safety regulations, especially with regard to explosion or fire-risk and the possibility of decomposition or generation of hazardous gases. Never mix synthetic with mineral oil.
- 15 Protect the engine, alternator, air intake filter, electrical and regulating components, etc., to prevent moisture ingress, e.g. when steam-cleaning.
- 16 When performing any operation involving heat, flames or sparks on a machine, the surrounding components shall first be screened with non-flammable material.
- 17 Never use a light source with open flame for inspecting the interior of a machine.
- 18 When repair has been completed, the machine shall be barred over at least one revolution for reciprocating machines, several revolutions for rotary ones to ensure that there is no mechanical interference within the machine or driver. Check the direction of rotation of electric motors when starting up the machine initially and after any alteration to the electrical connection(s) or switch gear, to check that the oil pump and the fan function properly.
- 19 Maintenance and repair work should be recorded in an operator's logbook for all machinery. Frequency and nature of repairs can reveal unsafe conditions.
- 20 When hot parts have to be handled, e.g. shrink fitting, special heat-resistant gloves shall be used and, if required, other body protection shall be applied.
- 21 When using cartridge type breathing filter equipment, ascertain that the correct type of cartridge is used and that its useful service life is not surpassed.
- 22 Make sure that oil, solvents and other substances likely to pollute the environment are properly disposed of.
- 23 Before clearing the unit for use after maintenance or overhaul, check that operating pressures, temperatures and speeds are correct and that the control and shutdown devices function correctly.

TOOL APPLICATIONS SAFETY

Apply the proper tool for each job. With the knowledge of correct tool use and knowing the limitations of tools, along with some common sense, many accidents can be prevented.

Special service tools are available for specific jobs and should be used when recommended. The use of these tools will save time and prevent damage to parts.

SPECIFIC SAFETY PRECAUTIONS

Batteries

When servicing batteries, always wear protecting clothing and glasses.

- 1 The electrolyte in batteries is a sulphuric acid solution which is fatal if it hits your eyes, and which can cause burns if it contacts your skin. Therefore, be careful when handling batteries, e.g. when checking the charge condition.
- 2 Install a sign prohibiting fire, open flame and smoking at the post where batteries are being charged.
- 3 When batteries are being charged, an explosive gas mixture forms in the cells and might escape through the vent holes in the plugs. Thus an explosive atmosphere may form around the battery if ventilation is poor, and can remain in and around the battery for several hours after it has been charged. Therefore:
 - never smoke near batteries being, or having recently been, charged,
 - never break live circuits at battery terminals, because a spark usually occurs.
- 4 When connecting an auxiliary battery (AB) in parallel to the unit battery (CB) with booster cables: connect the + pole of AB to the + pole of CB, then connect the - pole of CB to the mass of the unit. Disconnect in the reverse order.

Pressure vessels

(according to directive 87/404/EEC annex II § 2)

Maintenance/installation requirements:

- 1 The vessel can be used as pressure vessel or as separator and is designed to hold compressed air for the following application:
 - pressure vessel for compressor,
 - medium AIR/OIL,and operates as detailed on the data plate of the vessel:
 - the maximum working pressure ps in bar (psi),
 - the maximum working temperature Tmax in °C (°F),
 - the minimum working temperature Tmin in °C (°F),
 - the capacity of the vessel V in l (US gal, Imp gal, cu.ft).
- 2 The pressure vessel is only to be used for the applications as specified above and in accordance with the technical specifications. Safety reasons prohibit any other applications.
- 3 National legislation requirements with respect to re-inspection must be complied with.
- 4 No welding or heat treatment of any kind is permitted to those vessel walls which are exposed to pressure.
- 5 The vessel is provided and may only be used with the required safety equipment such as manometer, overpressure control devices, safety valve, etc.
- 6 Draining of condensate shall be performed regularly when vessel is in use.
- 7 Installation, design and connections should not be changed.
- 8 Bolts of cover and flanges may not be used for extra fixation.

Safety valves

All adjustments or repairs are to be done by an authorized representative of the valve supplier (see also **Preventive maintenance schedule for the compressor**).

Leading particulars

DESCRIPTION OF SAFETY PICTOGRAMS USED IN THIS MANUAL



This symbol draws your attention to dangerous situations. The operation concerned may endanger persons and cause injuries.



This symbol is followed by supplementary information.

GENERAL DESCRIPTION

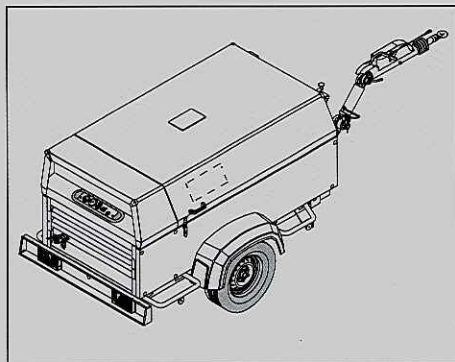

The compressors type XA(S) 137 DD - XA(S) 300 DD7, XA(S) 137 DDG - XA(S) 300 DD7G and XAHS 107 DD - XAHS 250 DD7 are silenced, single-stage, oil-injected screw compressors, built for a nominal effective working pressure, ranging from 7 bar (102 psi) up to 12 bar (175 psi) (see chapter **Technical specifications**).

Engine

The compressors are driven by an oil-cooled diesel engine.

The engine's power is transmitted to the compressor through a heavy-duty coupling.

Compressor

The compressor casing houses two screw-type rotors, mounted on ball and roller bearings. The male rotor, driven by the engine, drives the female rotor. The element delivers pulsation-free air.

Injected oil is used for sealing, cooling and lubricating purposes.

Compressor oil system

The oil is boosted by air pressure. The system has no oil pump.

The oil is removed from the air, in the air/oil vessel at first by centrifugal force, secondly by the oil separator element.

The vessel is provided with an oil level indicator.

Regulation

The compressor is provided with a continuous regulating system and a blow-down valve which is integrated in the unloader assembly. The valve is closed during operation by air receiver pressure and opens by air receiver pressure via the compressor element when the compressor is stopped.

When the air consumption increases, the air receiver pressure will decrease and vice versa.

This receiver pressure variation is sensed by the regulating valve which, by means of control air to the unloader and engine speed regulator, matches the air output to the air consumption. The air receiver pressure is maintained between the pre-selected working pressure and the corresponding unloading pressure.

Cooling system

The engine is equipped with an oil cooler. All compressors are equipped with an oil cooler.

The cooling air is generated by a fan, driven by the engine.

Safety devices

A thermal shut-down switch protects the compressor against overheating. The air receiver is provided with a safety valve.

The engine is equipped with low oil pressure and high oil temperature shut-down switches.

Frame and axle

The compressor/engine unit is supported by rubber buffers in the frame.

The standard unit has a non-adjustable towbar with a towing eye.

As an option the unit can be equipped with an adjustable towbar, an overrun and parking brake and towing eyes type DIN, ball, ITA, GB, NATO, AC (France), (see chapter **Available options**).

The braking system consists of an integrated parking brake and overrunbrake. When driving backwards the overrunbrake is not engaged automatically.

Bodywork

The bodywork has openings at the shaped front and rear end for the intake and outlet of cooling air and hinged door for maintenance and service operations. The bodywork is internally lined with sound-absorbing material.

Lifting eye

A lifting eye is accessible when the small door at the top of the unit is unlocked.

Control panel

The control panel grouping the air pressure gauge, control switch etc., is placed in the center at the rear end.

Data plate

The compressor is furnished with a data plate showing the product code, the unit number and the working pressure (see chapter **Data plate**).

Serial number

The serial number is located on the right-hand side towards the front on the upper edge of the frame and also on the data plate.

Generator - XA(S) 137 DDG - XA(S) 300 DD7G

The built-in generator is driven by a multi V-belt drive. The generated current can be drawn via 3 sockets (3 x 16 A, 2 x 3 phases, 1 x 1 phase).

The compressor and the generator of the XA(S) 137 DDG - XA(S) 300 DD7G may be used simultaneously.

Main Parts

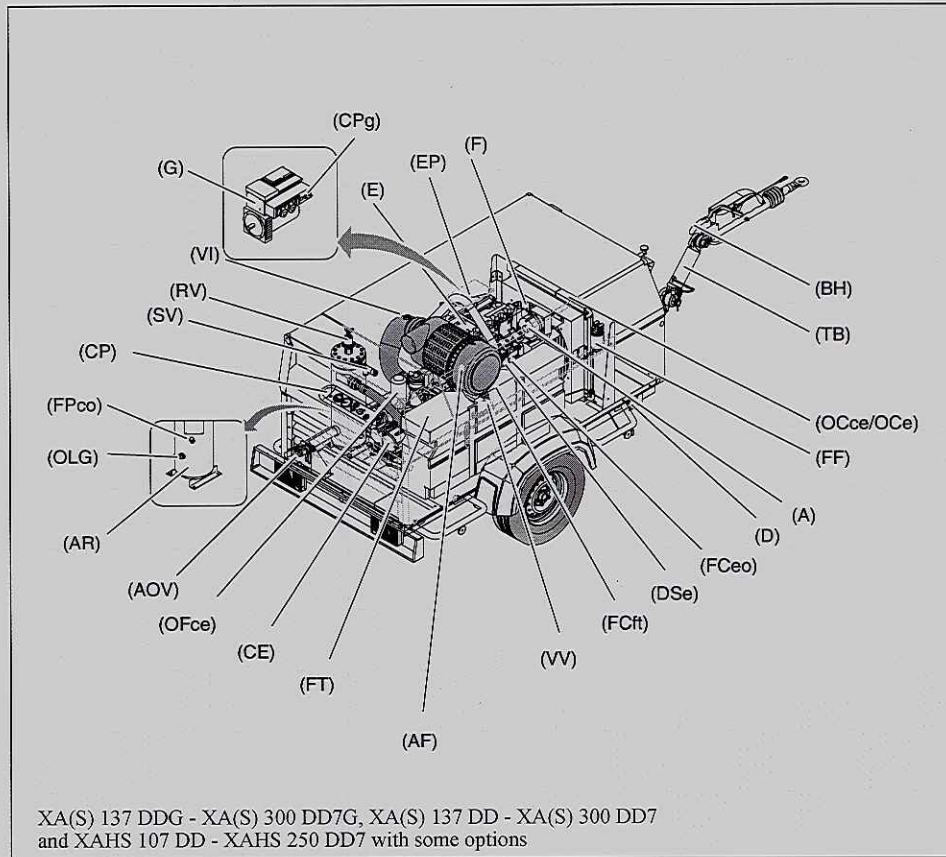

Reference	Name
A	Alternator
AF	Air Filter
AOV	Air Outlet Valves
AR	Air Receiver
BH	Brake Handle
CE	Compressor Element
CP	Control Panel
CPg	Control Panel Generator
D	Data plate
DSe	Engine Oil Level Dipstick
E	Engine
EP	Exhaust Pipe
F	Fan
FCeo	Filler Cap (engine oil)
FCft	Filler Cap (fuel tank)
FF	Fuel Filter
FPco	Filler Plug (oil compressor element)
FT	Fuel Tank
G	Generator

Reference	Name
OCce	Oil Cooler (compressor element)
OCe	Oil Cooler (engine)
OFce	Oil Filter (compressor element)
OLG	Oil Level Gauge (compressor element)
RV	Regulating Valve
SV	Safety Valve
TB	Towbar
VI	Vacuum Indicator
VV	Vacuator Valve

COMPRESSOR REGULATING SYSTEM

OVERVIEW (LOAD CONDITION)

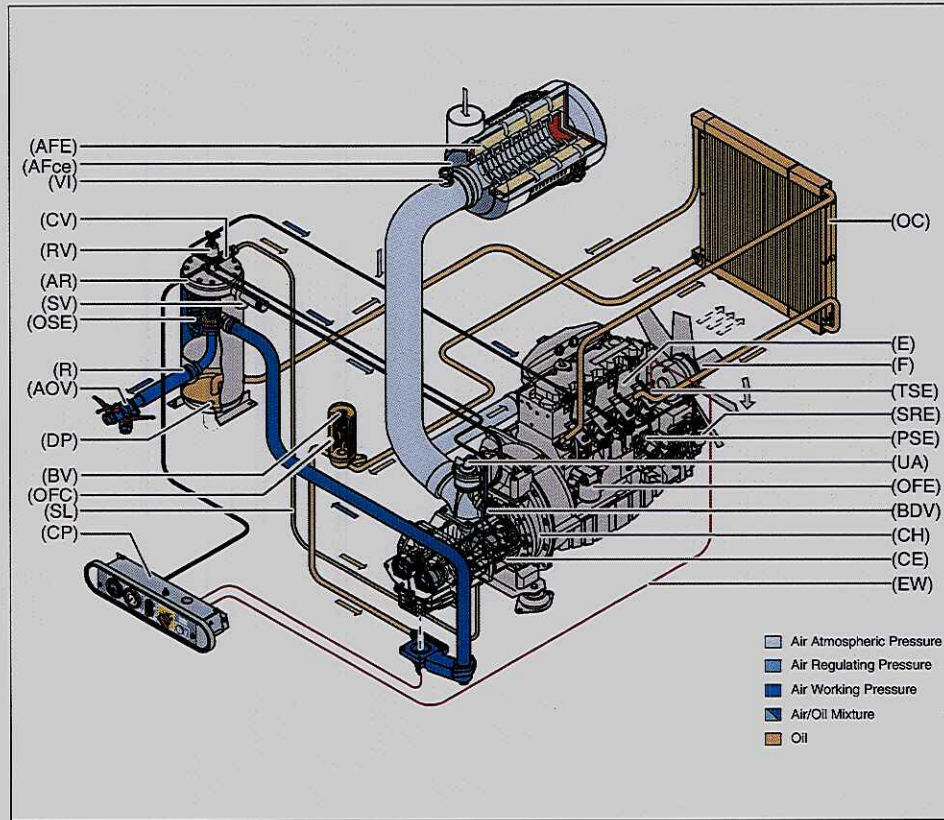

Reference	Name
AFce	Air Filter Compressor/Engine
AFE	Air Filter Element
AOV	Air Outlet Valves
AR	Air Receiver/Oil Separator
BDV	Blow Down Valve
BV	By-Pass Valve Oil Filter
CE	Compressor Element
CH	Coupling Housing
CP	Control Panel
CV	Check Valve
DP	Drain Plug
E	Engine
EW	Electrical Wiring
F	Cooling Fan
OC	Oil Cooler
OFC	Oil Filter Compressor
OFE	Oil Filter Engine
OSE	Oil Separator Element
PSE	Pressure Switch Engine
R	Restrictor
RV	Regulating Valve

AIR FLOW

The system comprises:

AFce	Air filter compressor/engine
AR/OSE	Air receiver/oil separator element
CE	Compressor element
UA/UV	Unloader assembly with unloader valve
BDV	Blow-down valve

Air drawn through the airfilter (AFce) into the compressor element (CE) is compressed. At the element outlet, compressed air and oil pass into the air receiver/oil separator (AR/OSE).

The check valve (CV) prevents blow-back of compressed air when the compressor is stopped. In the air receiver/oil separator (AR/OSE), most of the oil is removed from the air/oil mixture; the remaining oil is removed by the separator element.

The oil collects in the receiver and on the bottom of the separator element.

The air leaves the receiver via a restriction which prevents the receiver pressure from dropping below the minimum working pressure (specified in section **Limitations**), even when the air outlet valves are open. This ensures adequate oil injection and prevents oil consumption.

A temperature switch (TS) and a working pressure gauge (WPG) are comprised in the system.

A blow-down valve (BDV) is fitted in the unloader assembly to automatically depressurise the air receiver (AR) when the compressor is stopped.

OIL SYSTEM

The system comprises:

AR/OSE	Air receiver/oil separator
OC	Oil cooler
OF	Oil filter

The lower part of the air receiver (AR) serves as oil tank.

Air pressure forces the oil from the air receiver/oil separator (AR/OS) through the oil cooler (OCce) and oil filter (OF) to the compressor element (CE).

The compressor element has an oil gallery in the bottom of its casing. The oil for rotor lubrication, cooling and sealing is injected through holes in the gallery.

Lubrication of the bearings is ensured by oil injected into the bearing housings.

The injected oil, mixed with the compressed air, leaves the compressor element and re-enters the air receiver, where it is separated from the air as described in section **Air flow**. The oil that collects in the bottom of the oil separator element is returned to the system through scavenging line (SL), which is provided with a flow restrictor.

The oil filter by-pass valve opens when the pressure drop over the filter is above normal because of a clogged filter. The oil then by-passes the filter without being filtered. For this reason, the oil filter must be replaced at regular intervals (see section **Preventive maintenance schedule for the compressor**).

Reference	Name
SL	Scavenge Line
SRE	Speed Regulator Element
SV	Safety Valve
TSE	Temperature Switch Engine
UA	Unloader Assembly
VI	Vacuum Indicator

CONTINUOUS REGULATING SYSTEM

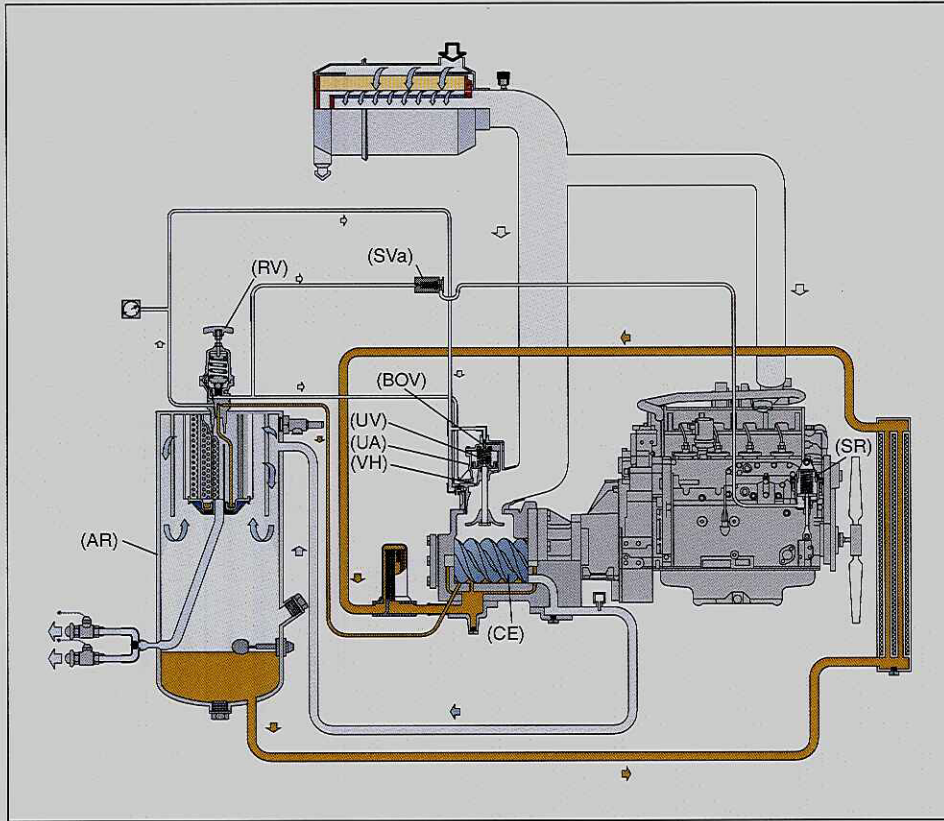

The system comprises:

- RV Regulating valve
- UA Unloader assembly
- SR Speed regulator

The compressor is provided with a continuous regulating system. This system is provided with a blow-down valve which is integrated in the unloader assembly (UA). The valve is closed during operation by air receiver pressure and opens by air receiver pressure via the compressor element when the compressor is stopped.

When the air consumption increases, the air receiver pressure will decrease and vice versa. This receiver pressure variation is sensed by the regulating valve which, by means of control air to the unloader, matches the air output to the air consumption. The air receiver pressure is maintained between the pre-selected working pressure and the corresponding unloading pressure.

When starting the compressor, the unloader valve (UV) is kept open by spring force, the engine runs at maximum speed. The compressor element (CE) takes in air and pressure builds up in the receiver (AR).

The air output is controlled from maximum output (100%) to no output (0%) by:

1. Speed control of the engine between maximum load speed and unloading speed (the output of a screw compressor is proportional to the rotating speed).
2. Air inlet throttling.
3. Blow off valve (BOV).

If the air consumption is equal to or exceeds the maximum air output, the engine speed is held at maximum load speed and the unloading valve is fully open.

If the air consumption is less than the maximum air output, the regulating valve supplies control air to unloader valve (UV) to reduce the air output and holds air receiver pressure between the normal working pressure and the corresponding unloading pressure of approx. 1.5 bar (22 psi) above the normal working pressure.

When the air consumption is resumed, the blow off valve (BOV) closes and the unloader valve (UV) gradually opens the air intake and the speed regulator (SR) increases the engine speed.

The construction of the regulating valve (RV) is such that any increase (decrease) of the air receiver pressure above the pre-set valve opening pressure results in a proportional increase (decrease) of the control pressure to the unloading valve and the speed regulator.

Part of the control air is vented to atmosphere, and any condensate discharged, through the vent holes (VH).

XA(S) 137 DDG - XA(S) 300 DD7G:

When the generator is switched on, the solenoid valve (SVa) via the speed regulator (SR) controls the motor and allows it to reach maximum speed (the normal control system is switched off).

ELECTRICAL SYSTEM

All compressors are equipped with a negative earthed system.

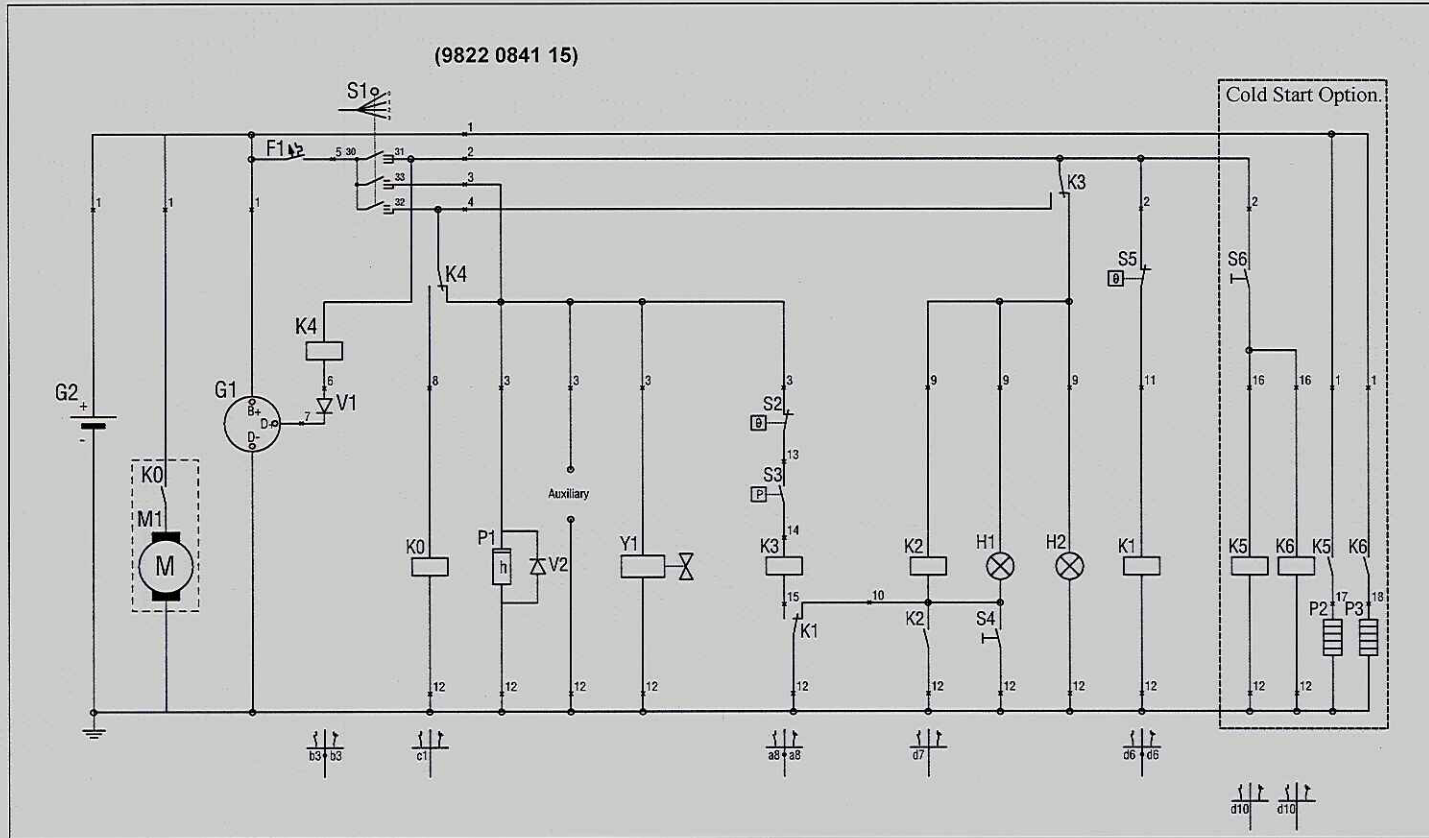

Reference	Name
F1	Circuit breaker
G1	Alternator
G2	Battery
H1	Lamp temperature alarm
H2	Lamp general alarm
K0	Starter solenoid (part of M1)
K1	Relay
K2	Relay
K3	Relay
K4	Relay
K5-K6	Relay heater plug
M1	Starter motor
P1	Hourmeter
P2-P3	Heater plug
S1	Contactswitch (Off-On-Override-Start)
S2	Temperature switch engine
S3	Oil pressure switch
S4	Temperature Lamptest switch
S5	Temperature switch compressor
S6	Coldstart switch
V1	Diode
V2	Diode
Y1	Fuel solenoid valve

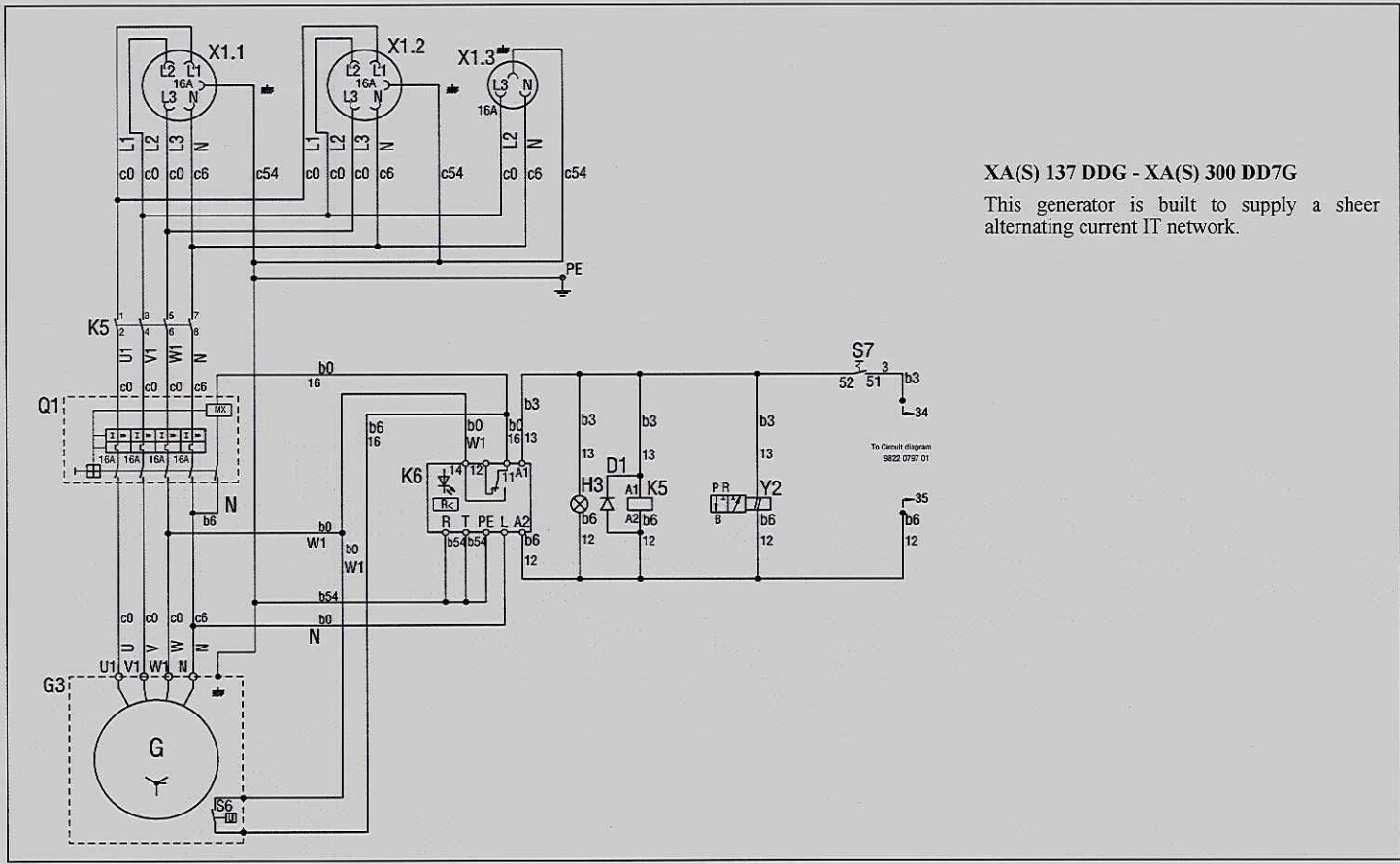

XA(S) 137 DDG - XA(S) 300 DD7G

This generator is built to supply a sheer alternating current IT network.

Reference	Name
D1	Diode
G3	Generator
H3	Lamp (Power control)
K5	Contactora 4-pole
K6	Insulation Monitoring Relay
Q1	Main circuit breaker 4-pole
S6	Thermal contact (N/O)
S7	Switch (Generator-compressor)
X1.1	Socket outlet
X1.2	Socket outlet
X1.3	Socket outlet
Y2	Solenoid valve (Generator operation)

DESCRIPTION











Generator function:





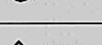

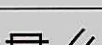





Turn switch S6 to position 1. The solenoid valve Y2G via the speed regulator SR controls the motor and allows it to reach maximum speed (the normal control system is switched off). Lamp H1 is activated (sockets X1.1, X1.2, X1.3 are under tension).











The generator can be switched off by turning switch S6 to position 0.

In the case of an insulation fault, lamp H2 of the system is activated. When the red lamp H2 is active, a reset can only be made by stopping and restarting the unit.

MARKINGS AND INFORMATION LABELS

	Compressor outlet temperature too high.
	Compressor outlet temperature.
	Compressor outlet pressure.
	Dangerous outlet gases.
	Danger, heat flat.
	Electrocution hazard.
	Atlas Copco mineral compressor oil.
	Atlas Copco synthetic compressor oil.
	Atlas Copco mineral engine oil.
	Manual.
	Read the instruction manual before working on the battery.
	Reset fuse.

	On / off button.
	Hours, time.
	Prohibition to open air valves without connected hoses.
	Compressor loaded.
	Runlamp.
	Airfilter.
	Compressor temperature too high.
	Rotation direction.
	Inlet.
	Outlet.
	Compressor oil drain.
	Read the instruction manual before starting.

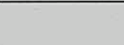
	Service every 24 hours.
	Warning! Part under pressure.
	Do not stand on outlet valves.
	Start-Stop indication of switch.
	Do not run the compressor with open doors.
	Lifting permitted.
	Use diesel fuel only.
	4.75 bar (69 psi) Tyre pressure.
	Sound power level in accordance with Directive 2000/14/EC (expressed in dB (A)).
	Sound power level in accordance with Directive 2000/14/EC (expressed in dB (A)).
	Sound power level in accordance with Directive 2000/14/EC (expressed in dB (A)).
	Horizontal towbar position required in case of coupling.

Operating instructions

PARKING INSTRUCTIONS

PARKING, TOWING AND LIFTING INSTRUCTIONS

Safety precautions



The operator is expected to apply all relevant safety precautions, including those mentioned on the pages 5 - 11 of this book.

Attention:



Before putting the compressor in to use, check the brake system as described in section Brake (= option) adjustment.

After the first 100 km travel:

Check and retighten the wheel nuts and towbar bolts to the specified torque. See section Height adjustment and section Torque values.

Check the brake adjustment. See section Brake (= option) adjustment.

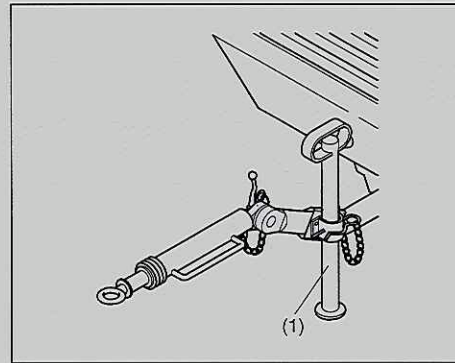

Non-adjustable towbar with standard support leg without brakes

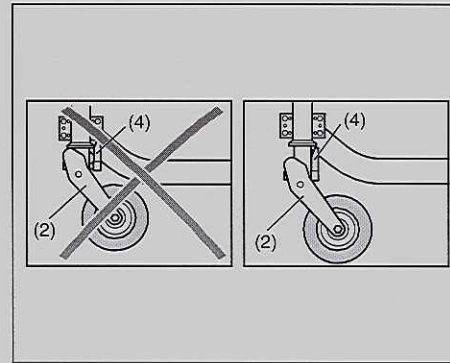

Parking position of jockey wheel

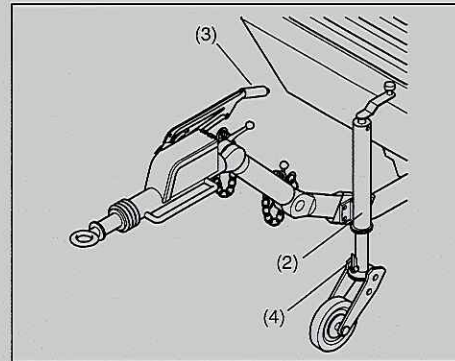

Adjustable towbar with jockey wheel and brakes

When parking a compressor, secure support leg (1) or jockey wheel (2) to support the compressor in a level position. Be sure that the jockey wheel (2) is blocked by the blocking pin (4).

Apply parking brake by pulling parking brake handle (3) upwards. Place the compressor as level as possible; however, it can be operated temporarily in an out-of-level position not exceeding 15°. If the compressor is parked on sloping ground, immobilize the compressor by placing wheel chocks (available as option) in front of or behind the wheels.

TOWING INSTRUCTIONS

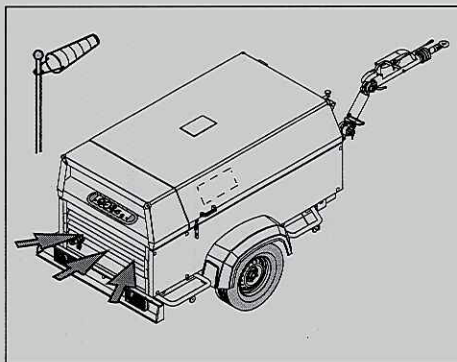

Locate the rear-end of the compressor upwind, away from contaminated wind-streams and walls. Avoid recirculation of exhaust air from the engine. This causes overheating and engine power decrease.

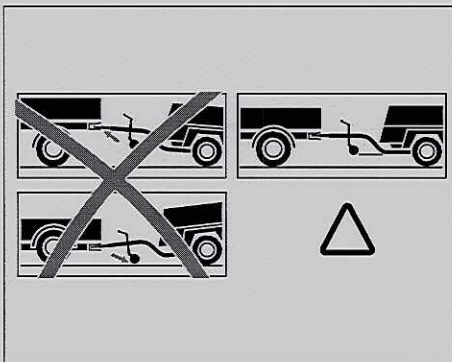

Label on towbar



Before towing the compressor, ensure that the towing equipment of the vehicle matches the towing eye or ball connector and ensure that the service doors are closed and locked properly.

For both non-adjustable - and adjustable towbar, the towbar should be as level as possible and the compressor and towing eye end in a level position.

Push the hand brake lever (1) completely downwards and connect breakaway cable (2) to the vehicle. Secure jockey wheel (3) or support leg in the highest possible position (see figure). The jockey wheel is prevented from turning.

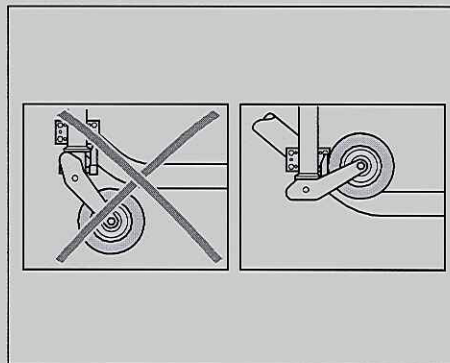
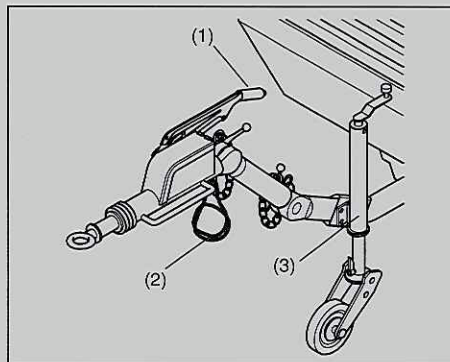

**HEIGHT ADJUSTMENT
(with adjustable towbar)**

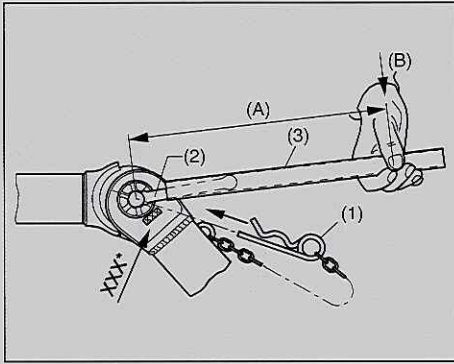

- Remove spring pin (1).
- Release locking nut (2) with support tools (Extension tube 3).
- Adjust required height of the towbar.
- Tighten locking nut (2) by hand first.
- Secondly tighten locking nut (2) with a tightening torque corresponding to table. With an extension tube (3) ("A" corresponding to table 1) and handforce ("B" corresponding to table 1) easy tightening is possible.
- Fix locking nut (2) with spring pin (1).



Attention:

- Height adjustment should be undertaken on levelled ground and in coupled condition.
- When readjusting, make sure that the front point of the towbar is horizontal to the coupling point.
- Before starting a trip, ensure that the adjustment shaft is secure, so that the stability and safety is guaranteed while driving. If necessary tighten the locking nut (2) corresponding to table.



Before towing the compressor, make sure that the joints of the towbar are secured with maximum strength without damaging the towbar. Be sure that there is no clearance between the teeth of the joints.

For specific instruction see below!

Type	M [Nm/lbf.ft.]	"A" [mm/in]	"B" [N/lbf]
*ZV 2000	250 - 300 / 184.5 - 221.4	600 / 23.4	420 - 500 / 94.5 - 112.5
*ZV 2500	350 - 400 / 258.3 - 295.2	600 / 23.4	580 - 660 / 130.5 - 148.5

LIFTING INSTRUCTIONS

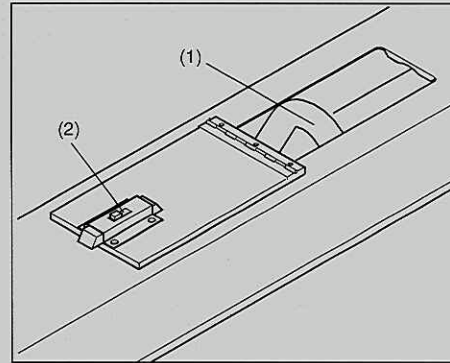

When lifting the compressor, the hoist has to be placed in such a way that the compressor, which must be placed level, will be lifted vertically. Keep lifting acceleration and retardation within safe limits.

Preferably use the lifting eye (1) herefore open the small door (2).



Lifting acceleration and retardation must be kept within safe limits (max. 2g).

Helicopter lifting is not allowed.

Lifting is not allowed when the unit is running.

STARTING/STOPPING

CONTROL PANEL (WITH COLD START; OPTION)

BEFORE STARTING

1. Before initial start-up, prepare battery for operation if not already done. See section **Battery care**.
2. With the compressor standing level, check the level of the engine oil. Add oil, if necessary, to the upper mark on dipstick. Consult the Engine Operation Manual for the type and viscosity grade of the engine oil.
3. Check the level of the compressor oil. See section **Compressor regulating system**. The pointer of oil level gauge (OLG) should register in the green range. Add oil if necessary. See section **Lubrication oils** for the oil to be used.



Before removing oil filler plug (FP), ensure that the pressure is released by opening an air outlet valve.

4. Check that the fuel tank contains sufficient fuel. Top up, if necessary. Consult the Engine Operation Manual for the type of fuel.
5. Drain any water and sediment from the fuel filter until clean fuel flows from the drain cock.
6. Press vacuator valves (VV) of the air filters to remove dust.
7. Check the air filter vacuum indicators (VI). If the yellow piston reaches the red marked service range, replace the filter element. Reset the indicator by pushing the reset button.
8. Open air outlet valve to allow air flow to the atmosphere.

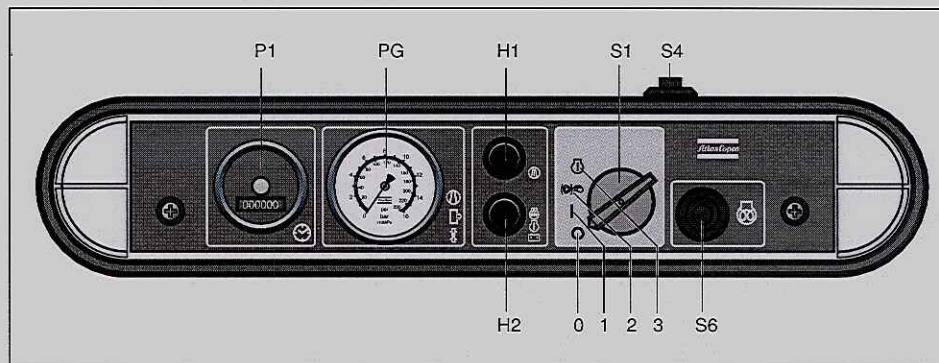



Reference	Name
P1	Hourmeter
PG	Working pressure gauge
H1	Temperature alarm lamp (red)
H2	General alarm lamp (red)
S1	Start switch
S4	Lamp test button
S6	Cold start button

Starting procedure

 The control panel indicates receiver pressure (PG) and accumulated operating hours (P1).

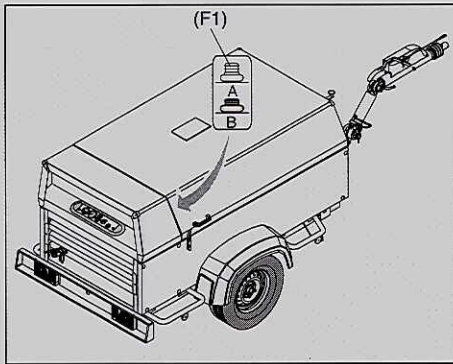
Before starting open the air outlet valve(s) (see section **Compressor regulating system**, AOV) and push circuit breaker button (F1) once (open hood first). Circuit breaker button should now be in position B. To preheat if necessary, first push the cold start button S6 for a short period.



 The circuit breaker button is a protection against unintended starting of the compressor.

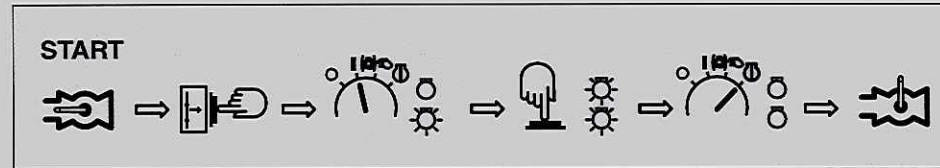

1. To start, turn start switch S1 clockwise to position 1, lamp H2 (general alarm lamp) will go on.
2. Check correct operation of alarm lamps H1 and H2 by pushing lamp test button S4. Both alarm lamps (red) should go on.
3. Turn start switch S1 further clockwise into position 3.
4. The start switch automatically springs back to position 1.
Lamp H1 only will go on when the compressor outlet temperature is too high.
5. Close the air outlet valve(s) (AOV).

The starter motor will set the engine in motion.

The maximum allowed starter time, where the starter motor is running continuously is 20 seconds.

If the engine does not catch, a new attempt can be made after 30 seconds waiting.

The temperature alarm lamp H1 and the general alarm lamp H2 will go out as soon as the engine has been started.

CONTROL PANEL (WITHOUT COLD START)

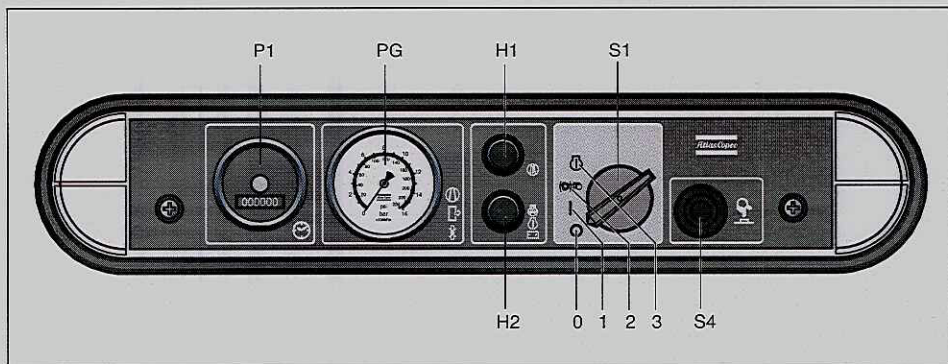

Reference	Name
P1	Hourmeter
F1	Circuit breaker button
PG	Working pressure gauge
H1	Temperature alarm lamp (red)
H2	General alarm lamp (red)
S1	Start switch
S4	Lamp test button

 The control panel indicates receiver pressure (PG) and accumulated operating hours (P1).

Before starting open the air outlet valve(s) (see section **Compressor regulating system, AOV**) and push circuit breaker button (F1) once (open hood first). Circuit breaker button should now be in position B.

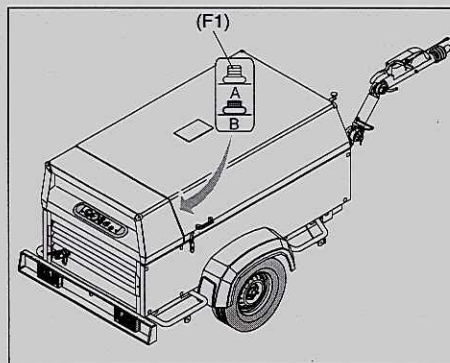

 The circuit breaker button is a protection against unintended starting of the compressor.

Starting procedure

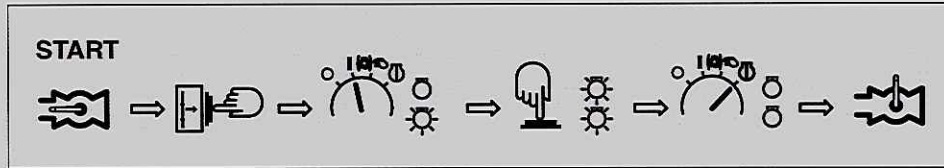

1. To start, turn start switch S1 clockwise to position 1, lamp H2 (general alarm lamp) will go on.
2. Check correct operation of alarm lamps H1 and H2 by pushing lamp test button S4. Both alarm lamps (red) should go on.
3. Turn start switch S1 further clockwise into position 3.
4. The start switch automatically springs back to position 1.
Lamp H1 only will go on when the compressor outlet temperature is too high.
5. Close the air outlet valve(s) (AOV).

The starter motor will set the engine in motion.

The maximum allowed starter time, where the starter motor is running continuously is 20 seconds.

If the engine does not catch, a new attempt can be made after 30 seconds waiting.

The temperature alarm lamp H1 and the general alarm lamp H2 will go out as soon as the engine has been started.

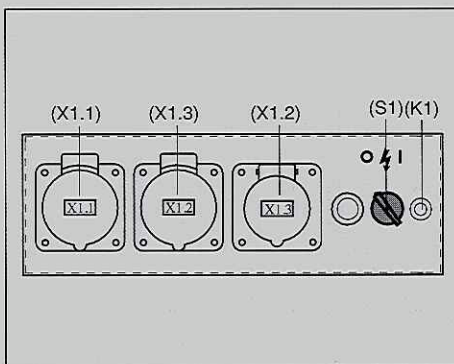

Control panel (generator)

X1.1 Socket 400 V/16 A X1.3 Socket 230 V/16 A
 X1.2 Socket 400 V/16 A S1 ON/OFF switch
 K1 Earthing clamp

Start the unit in accordance with the normal procedure. Let the motor warm up until it reaches operational temperature.

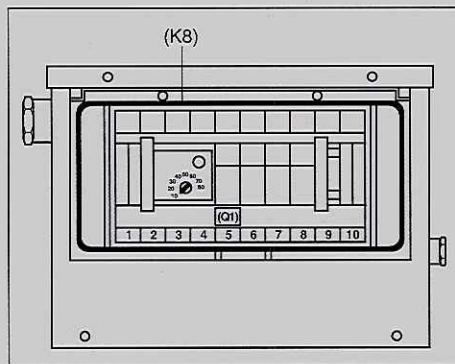

Generator control box

Q1 Main circuit breaker 4-pole
 K8 Insulation monitoring relay



Before connecting an electrical device, always check the data listed on the rating plate.

Fault situations and protective devices:

- Open the left machine door and check that the circuit breakers are up. If the circuit breakers are down, put them up (switch them on). Circuit breakers in the up position can be indicative of a serious electrical fault.
- When the red lamp H9 is activated, it means that a serious insulation fault has occurred. Reset by first switching off the motor, then restart it.
- The insulation monitoring relay K8 must be adjusted to 10 kΩ. This adjustment may not be changed.

DURING OPERATION



When the engine is running, the air outlet valves (ball valves) must always be put in a fully opened or fully closed position.

Regularly carry out following checks:

1. That regulating valve (see section **Main Parts, RV**) is correctly adjusted, i.e. starts decreasing the engine speed when reaching the preset working pressure in the receiver.
2. Check the air filter vacuum indicators (see section **Main Parts, VI**). If the yellow piston reaches the red marked service range, replace the filter element. Reset the indicators by pushing the reset button.



The doors must be closed during operation and may be opened for short periods only.

STOPPING PROCEDURE

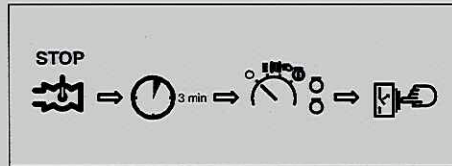

1. Close the air outlet valves (see section **Compressor regulating system, AOV**).
2. Run unloaded for 3 minutes.
3. Turn the start switch S1 counterclockwise (CCW) to position 0.
4. Push the circuit breaker button (F1) once (open hood first). Circuit breaker button should now be in position A.

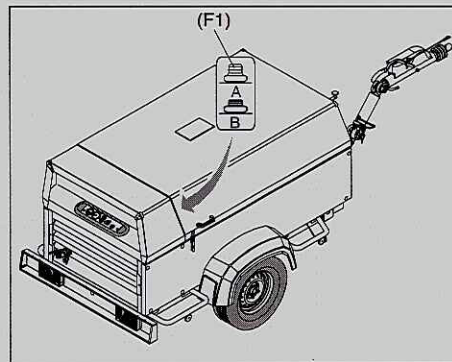

Maintenance

USE OF SERVICE PAKS

Service Paks include all genuine parts needed for normal maintenance of both compressor and engine.

Service Paks minimize downtime and keep your maintenance budget low.

Order Service Paks at your local Atlas Copco dealer.

PREVENTIVE MAINTENANCE SCHEDULE FOR THE COMPRESSOR

The schedule contains a summary of the maintenance instructions. Read the respective section before taking maintenance measures.

When servicing, replace all disengaged packings, e.g. gaskets, O-rings, washers.

For engine maintenance refer to Engine Operation Manual.

The maintenance schedule has to be seen as a guideline for units operating in a dusty environment typical to compressor applications. Maintenance schedule can be adapted depending on application environment and quality of maintenance.

Maintenance schedule	Daily	Initially	Every 500 hours	Every 1000 hours
Service pak XA(H)(S) 107-137 / 250-300 DD(7)G Standard			2912 4490 05	2912 4481 06
Service pak XA(H)(S) 107-137 / 250-300 DD(7)G Heavy duty filter system (option)			2912 4492 05	2912 4491 06
Engine oil level	Check			
Compressor oil level	Check			
Air filter vacuator valves	Empty			
Fuel filter water drain	Drain			
Air intake vacuum indicators	Check			
Electrolyte level and terminals of battery		Check	Check	Check
Tyre pressure		Check	Check	Check
Leaks in air-, oil- or fuel system		Check	Check	Check
Oil coolers			Clean	Clean
Engine minimum and maximum speeds		Check	Check	Check

(to be continued on page 35)

Maintenance schedule <i>(continuation of page 34)</i>	Daily	Initially	Every 500 hours	Every 1000 hours
Torque of wheel nuts		Check	Check	Check
Brake system (if installed)		Check/Adjust	Check/Adjust	Check/Adjust
Safety valve				Test
Door hinges			Grease	Grease
Coupling head and all its moving parts / shaft			Grease	Grease
Joints of height adjustment adjustable towbar		Check	Grease	Grease
Shutdown switches				Check
Pressure drop over separator element (2)			Measure	Replace (6)
Fan V-belts (3)			Adjust	Adjust
Fuel tank			Clean	Clean
Compressor oil				Change
Compressor oil filter				Replace
Air filter elements (1)				Replace
Safety cartridges (1) (option)				Replace
Engine oil (3) (4)			Change	Change
Engine oil filter (3)			Replace	Replace
Fuel filter (3) (5)			Replace	Replace
Fuel prefilter (3)			Replace	Replace
Engine inlet and outlet valves (3)				Adjust
DD/PD filter (option)				Replace

(to be continued on page 36)

Notes



1. More frequently when operating in a dusty environment.
2. Replace the element when the pressure drop exceeds 0.8 bar (11.6 psi).
3. Refer to the Deutz operation manual.
4. 500 hours only valid when using PAROIL SAE 15W40.
5. In case of poor fuel quality, replace fuel filter more frequently.
6. Clean retainer when replacing element.



Keep the bolts of the housing, the lifting eye, the towbar and the axle securely tightened.

Refer to section Technical specifications and section Height adjustment for the torque values.

LUBRICATION OILS

High-quality, mineral, hydraulic or synthesized hydrocarbon oil with rust and oxidation inhibitors and anti-foam and anti-wear properties is recommended. The viscosity grade should correspond to the ambient temperature and ISO 3448, as follows:

Type of lubricant	Compressor**	Engine*
between -25°C (-13°F) and -50°C (122°F)	PAROIL S	PAROIL 5W40
between -10°C (14°F) and +50°C (122°F)	PAROIL M	PAROIL 15W40

PAROIL from Atlas Copco is the ONLY oil tested and approved for use in all engines built into Atlas Copco compressors and generators.

Extensive laboratory and field endurance tests on Atlas Copco equipment have proven PAROIL to match all lubrication demands in varied conditions. It meets stringent quality control specifications to ensure your equipment will run smoothly and reliably.

The quality lubricant additives in PAROIL allow for extended oil change intervals without any loss in performance or longevity.

PAROIL provides wear protection under extreme conditions. Powerful oxidation resistance, high chemical stability and rust-inhibiting additives help reduce corrosion, even within engines left idle for extended periods.

PAROIL contains high quality anti-oxidants to control deposits, sludge and contaminants that tend to build up under very high temperatures.

PAROIL's detergent additives keep sludge forming particles in a fine suspension instead of allowing them to clog your filter and accumulate in the valve/rocker cover area.

PAROIL releases excess heat efficiently, whilst maintaining excellent bore-polish protection to limit oil consumption.

PAROIL has an excellent Total Base Number (TBN) retention and more alkalinity to control acid formation.

PAROIL prevents Soot build-up

PAROIL is optimized for the latest low emission EURO -3 & -2, EPA TIER II & III engines running on low sulphur diesel for lower oil and fuel consumption.

PAROIL 5W40 is a Synthetic ultra high performance diesel engine oil with a high viscosity- index. Atlas Copco PAROIL 5W40 is designed to provide excellent lubrication from start-up in temperatures as low as -25°C (-13°F).

PAROIL 15W40 is a mineral based high performance diesel engine oil with a high viscosity- index. Atlas Copco PAROIL 15W40 is designed to provide a high level of performance and protection in 'standard' ambient conditions as from -15°C (5°F).





*
If you want to use another brand of oil, consult the Engine Operation Manual.



**
It is strongly recommended to use Atlas Copco branded lubrication oils for both compressor and engine. If you want to use another brand of oil, consult Atlas Copco.



Never mix synthetic with mineral oil.

Remark:

When changing from mineral to synthetic oil (or the other way around), you will need to do an extra rinse:

After doing the complete change procedure to synthetic oil, run the unit for a few minutes to allow good and complete circulation of the synthetic oil. Then drain the synthetic oil again and fill again with new synthetic oil. To set correct oil levels, proceed as in normal instruction.

Mineral compressor oil PAROIL M

	Liter	US gal	Order number
can	5	1.3	1615 5947 00
can	20	5.3	1615 5948 00
barrel	210	55.2	1615 5949 00

Synthetic compressor oil PAROIL S

	Liter	US gal	Order number
can	5	1.3	1615 5950 01
can	20	5.3	1615 5951 01
barrel	210	55.2	1615 5952 01
container	1000	265	1604 7422 00

Mineral engine oil PAROIL 15W40

	Liter	US gal	Order number
can	5	1.3	1615 5953 00
can	20	5.3	1615 5954 00
barrel	210	55.2	1615 5955 00

Synthetic engine oil PAROIL 5W40

	Liter	US gal	Order number
can	5	1.3	1604 6060 00
can	20	5.3	1604 6059 00



OIL LEVEL CHECK



Never mix oils of different brands or types.

Use only non-toxic oils where there is a risk of inhaling delivered air.

CHECK COMPRESSOR OIL LEVEL

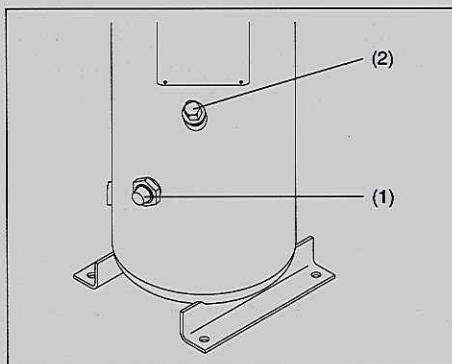

With the unit standing level, check the level of the compressor oil. The pointer of the oil level gauge (1) must register in the upper extremity of the green range. Add oil if necessary.



Before removing oil filler plug (2), ensure that the pressure is released by opening an air outlet valve.

ENGINE OIL AND OIL FILTER CHANGE

For replacing the engine oil filter, see section **Preventive maintenance schedule for the compressor**.

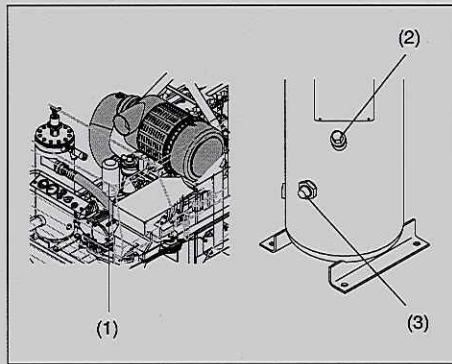

The quality and the temperature of the oil determine the oil change interval.

The prescribed interval (see section **Preventive maintenance schedule for the compressor**) is based on an oil temperature of up to 100 °C (212 °F) and normal operating conditions.

When operating in high ambient temperatures, in very dusty or high humidity conditions, it is recommended to change the oil more frequently.



In this case, contact Atlas Copco.

1. Run the compressor until warm. Close the outlet valve(s) and stop the compressor. Wait until the pressure is released through the automatic blow-down valve. Unscrew the oil filler plug (2) one turn. This uncovers a vent hole, which permits any pressure in the system to escape.

2. Drain the oil by removing all relevant drain plugs. Drain plugs are located at the air receiver, compressor element and compressor oil cooler. Catch the oil in a drain pan. Screw out the filler plug to speed up draining. Tighten the plugs after draining.
3. Remove the oil filter (1), e.g. by means of a special tool. Catch the oil in a drain pan.
4. Clean the filter seat on the manifold, taking care that no dirt drops into the system. Oil the gasket of the new filter element. Screw it into place until the gasket contacts its seat, then tighten one half turn only.
5. Fill the air receiver until the pointer of the oil level gauge (3) registers in the upper extremity of the green range. Take care that no dirt drops into the system. Reinstall and tighten the filler plug.
6. Run the unit at no load for a few minutes to circulate the oil and to evacuate the air trapped in the oil system.
7. Stop the compressor. Let the oil settle for a few minutes. Check that the pressure is released by opening an air outlet valve. Screw out filler plug (2) and add oil until the pointer of the oil level gauge (3) again registers in the upper extremity of the green range. Reinstall and tighten the filler plug.



Never add more oil. Overfilling results in oil consumption.

CLEANING COOLERS

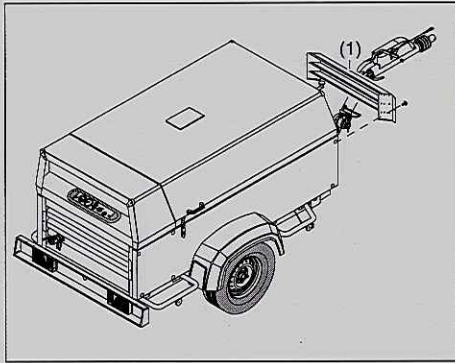

Keep the coolers clean to maintain the cooling efficiency.



Remove any dirt from the coolers with a fibre brush. Never use a wire brush or metal objects.

Remove the baffle (1). Then clean by air jet in reverse direction of normal flow.

Steam cleaning in combination with a cleansing agent may be applied.



To avoid damaging the coolers, angle between jet and coolers should be approx. 90°. (do not use jet at max. power)



Protect the electrical and controlling equipment, air filters, etc. against penetration of moisture.

Install the baffle (1).



Never leave spilled liquids such as fuel, oil, water and cleansing agents in or around the compressor.

BATTERY CARE



Before handling batteries, read the relevant safety precautions and act accordingly.

If the battery is still dry, it must be activated as described in section **Activating a dry-charged battery**.

The battery must be in operation within 2 months from being activated; if not, it needs to be recharged first.

ELECTROLYTE



Read the safety instructions carefully.

Electrolyte in batteries is a sulphuric acid solution in distilled water.

The solution must be made up before being introduced into the battery.

ACTIVATING A DRY-CHARGED BATTERY

- Take out the battery.
- Battery and electrolyte must be at equal temperature above 10°C (50°F).
- Remove cover and/or plug from each cell.
- Fill each cell with electrolyte until the level reaches 10 mm (0.4 in) to 15 mm (0.6 in) above the plates, or to the level marked on the battery.
- Rock the battery a few times so that possible air bubbles can escape; wait 10 minutes and check the level in each cell once more; if required, add electrolyte.
- Refit plugs and/or cover.
- Place the battery in the compressor.

RECHARGING A BATTERY

Before and after charging a battery, always check the electrolyte level in each cell; if required, top up with distilled water only. When charging batteries, each cell must be open, i.e. plugs and/or cover removed.



Use a commercial automatic battery charger according to its manufacturer's instructions.

Apply with preference the slow charging method and adjust the charge current according to the following rule of thumb:

battery capacity in Ah divided by 20 gives safe charging current in Amp.

BATTERY MAINTENANCE

- Keep the battery clean and dry.
- Keep the electrolyte level at 10 mm (0.4 in) to 15 mm (0.6 in) above the plates or at the indicated level; top up with distilled water only.
- Keep the terminals and clamps tight, clean, and lightly covered with petroleum jelly.

STORAGE

Run the compressor regularly, e.g. twice a week, until warm.

Load and unload the compressor a few times to operate the unloading and regulating components. Close the air outlet valves after stopping.



If the compressor is going to be stored without running from time to time, protective measures must be taken.

SERVICE PAKS

A Service Pak is a collection of parts to be used for a specific maintenance measure.

It guarantees that all necessary parts are replaced at the same time keeping down time to a minimum.

The order number of the Service Paks are listed in the Atlas Copco Parts List.

SERVICE KITS

A service kit is a collection of parts to fit a specific repair or rebuilding task.

It guarantees that all necessary parts are replaced at the same time which improves the uptime of the unit.

The order numbers of the Service Kits are listed in the Atlas Copco Parts List.



Contact Atlas Copco.

COMPRESSOR ELEMENT OVERHAUL

When a compressor element is due for overhaul, it is recommended to have it done by Atlas Copco. This guarantees the use of genuine parts and correct tools with care and precision.

LIABILITY

The manufacturer does not accept any liability for any damage arising from the use of non-original parts and for modifications, additions or conversions made without the manufacturer's approval in writing.

Adjustments and servicing procedures

ADJUSTMENT OF THE CONTINUOUS REGULATING SYSTEM

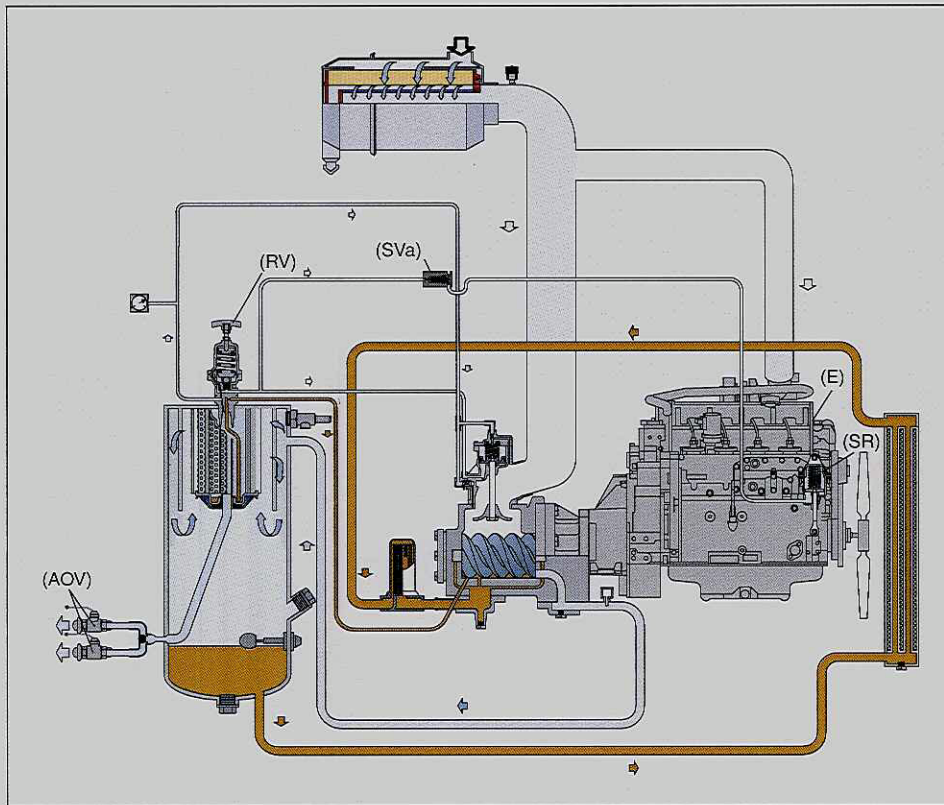

The working pressure is determined by the tension of the spring in the regulating valve (RV). This tension can be increased to raise the pressure and decreased to lower it by turning the adjusting wheel clockwise and anti-clockwise respectively.



The solenoid valve (SVa) is only present at units equipped with a generator (XA(S) 137 DDG - XA(S) 300 DD7G).

		X	Y	Z1 – Z2
XA(S) 137 DD - XA(S) 300 DD7	bar(e)	8.3	7	8.1 – 8.5
	psi	120.5	101.5	117.5 – 123.5
XA(S) 137 DDG - XA(S) 300 DD7G	bar(e)	8.3	7	8.1 – 8.5
	psi	120.5	101.5	117.5 – 123.5
XAHS 107 DD - XAHS 250 DD7	bar(e)	13.4	12	13.2 – 13.6
	psi	194.5	174	191.5 – 197.5

To adjust the normal working pressure, proceed as follows:

1. Start and warm up the engine (see section **Starting/Stopping**).
2. With the outlet valves (AOV) closed, loosen the regulating valve's lock nut and adjust the regulating valve (RV) until a pressure of X bar(e) is reached (see table).
3. Check the minimum speed of the engine. Adjust minimum speed stop screw if necessary.
4. Open an outlet valve (AOV) just enough to let the engine (E) run at maximum speed. The working pressure must be Y bar(e); adjust if necessary with regulating valve (RV) (see table).
5. Check the engine maximum speed. Adjust the maximum speed by means of adjusting eccentric nut on top of speed regulator (SR).
6. Close the outlet valves (AOV), check that the pressure is between Z1 and Z2 bar(e) (see table). Lock the regulating valve (RV) by fixing the lock nut.

AIR FILTER ENGINE/COMPRESSOR



The Atlas Copco air filters are specially designed for the application. The use of non-genuine air filters may lead to severe damage of engine and/or compressor element.

Never run the compressor without air filter element.

SERVICING

Always select the service point according to the vacuum indicator or display message. A regular inspection or cleaning as it is sometimes practiced in the field is more likely to be damaging than useful as there is a risk that the element will be damaged and dust will gain access to the engine.

Atlas Copco always recommends exchanging rather than cleaning the filter element in order to avoid damage and ensure maximum engine protection.

MAIN PARTS

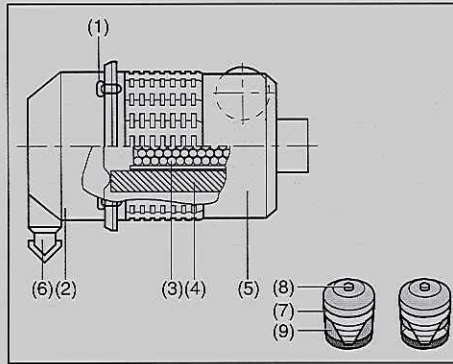

- | | |
|------------------------------|---------------------|
| 1. Snap clips | 6. Vacuator valve |
| 2. Dust trap cover | 7. Vacuum indicator |
| 3. Safety cartridge (option) | 8. Reset button |
| 4. Filter element | 9. Yellow indicator |
| 5. Filter housing | |

CLEANING THE DUST TRAP

Remove dust daily.

To remove dust from the dust trap pinch the vacuator valve (6) several times.

CLEANING INSTRUCTIONS FILTER ELEMENT

If element cleaning can not be avoided, care should be taken that the filter element (4) is not washed out. Please note that engine damage can cause considerable costs, which makes the cost of a new filter element seem insignificant.

Safety cartridges (3) can not be cleaned but must be exchanged.

Please note that a cleaned element will never match the service life and performance of a new element.

Take the element from the air filter housing (5) (see section **Replacing the air filter element**).

In order to clean, position a pipe with an end bent by approx. 90° on the end of a compressed-air pistol. The pipe must be long enough to reach the bottom of the filter element. Carefully blow out the filter element with dry compressed air (max. 5 bar (72.5 psi)) from the inside to the outside until there is no more development of dust. The end of the pipe must not touch the element.

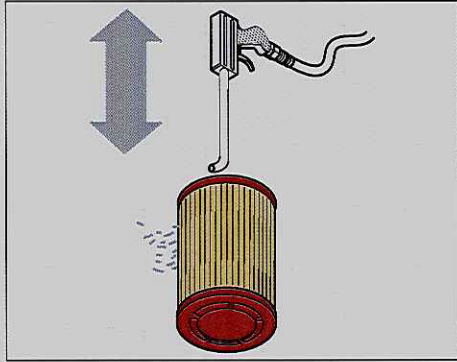

Next carefully examine the element for possible damage. Never beat or knock the element as this will damage it and there will be a danger of damage to the engine.

Carefully clean the inside of the housing and put the element in the housing (see section **Replacing the air filter element**).

REPLACING THE AIR FILTER ELEMENT

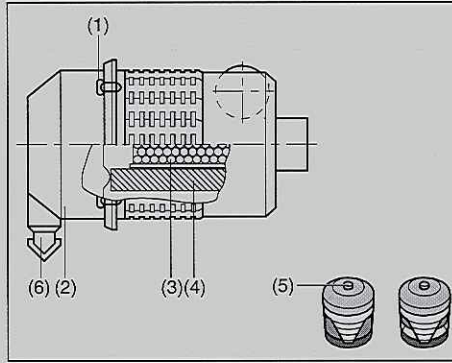

New elements must also be inspected for tears or punctures before installation.

Discard the element (4) when damaged.

In heavy duty applications it is recommended to install a safety cartridge which can be ordered with part no.: 2914 9311 00.

A dirty safety cartridge (3) is an indication of a malfunctioning air filter element. Replace the element and the safety cartridge in this case.

The safety cartridge cannot be cleaned.

1. Release the snap clips (1) and remove the dust trap (2). Clean the trap.
2. Remove the element (4) and the safety cartridge.
3. Reassemble in reverse order of dismantling. Make sure the vacuator valve (6) points down.
4. Inspect and tighten all air intake connections.
5. Reset the vacuum indicator by pressing the reset button (5).

AIR RECEIVER

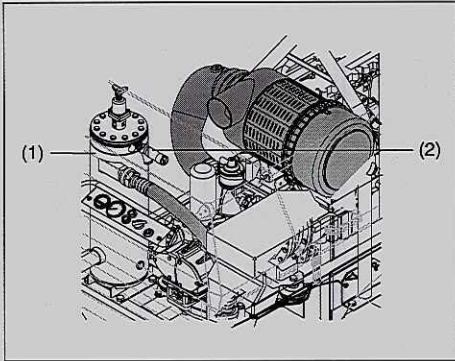

The air receiver (1) is tested according to official standards. Regularly have inspections carried out in conformity with local regulations.

SAFETY VALVE



All adjustments or repairs are to be done by an authorized representative of the valve supplier.

Following checks must be carried out on the safety valve (2):

- a check of the opening of the lifting gear, twice a year. This can be done by screwing the cap of the valve anti-clockwise.
- a check of the set pressure once a year according to the local regulations. This check cannot be done on the machine and must be carried out on a proper test bench.

FUEL SYSTEM

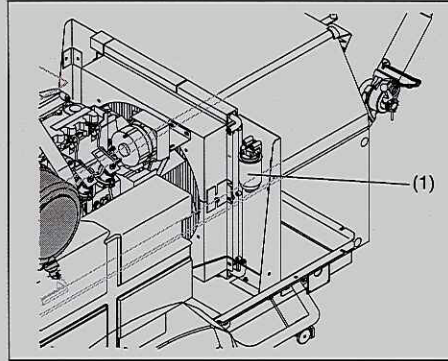

Replacing the filter element

1. Unscrew the filter element (1) from the adapter head.
2. Clean the adapter head sealing surface. Lightly oil the gasket of the new element and screw the latter onto the header until the gasket is properly seated, then tighten with both hands.
3. Check for fuel leaks once the engine has been restarted.

BRAKE (= OPTION) ADJUSTMENT



Before jacking up the compressor, connect it to a towing vehicle or attach a weight of minimum 50 kg (110 lb) to the towbar.

BRAKE SHOE ADJUSTMENT

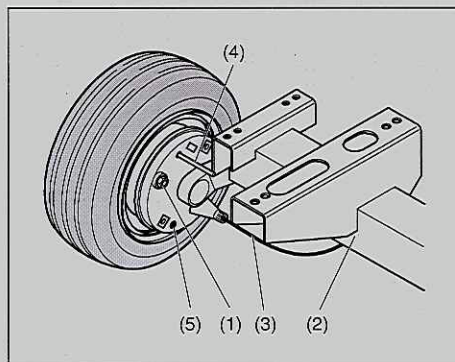

- | | |
|-------------------|---------------------------|
| 1. Adjusting bolt | 4. Pin \varnothing 4 mm |
| 2. Axle | 5. Plug |
| 3. Brake cable | |

Check the thickness of the brake lining. Remove both black plastic plugs (5), one on each wheel. When the brake lining has been worn to a thickness of 1 mm (0.039 in) or less, the brake shoes have to be replaced. After inspection and/or replacement re-insert both plugs.

Brake shoe adjustment re-establishes the brake lining-to-drum clearance and compensates for lining wear.

Lift and support the compressor. Make sure that all brakes are off (overrunbrake and hand brake lever). The brake cables must be free from tension. Lock the swivel cams of the wheel brake from the outside by means of a pin \varnothing 4 mm (4) through the hole as shown in the Figure.

Turn the adjusting bolt (1) clockwise with a wrench till the wheel locks up. Center the brake shoes by actuating the parking brake several times.

Turn the adjusting bolt anti-clockwise until the wheel is running free in direction of travel (approx. 1 full turn of the adjusting bolt).

Check the position of the equalizer (see section **Brake cable adjustment**, 6) with the parking brake actuated.

Perpendicular position of equalizer = identical clearance of wheel brakes.

Re-adjust the brake shoes, if necessary.

To test, slightly apply the parking brake and check identical brake torque on left and right side.

Remove locking pin (4). Remove clearance from brake cables.

Check all lock nuts (**Brake cable adjustment**, 2).

TEST PROCEDURE OF BRAKE CABLE ADJUSTMENT

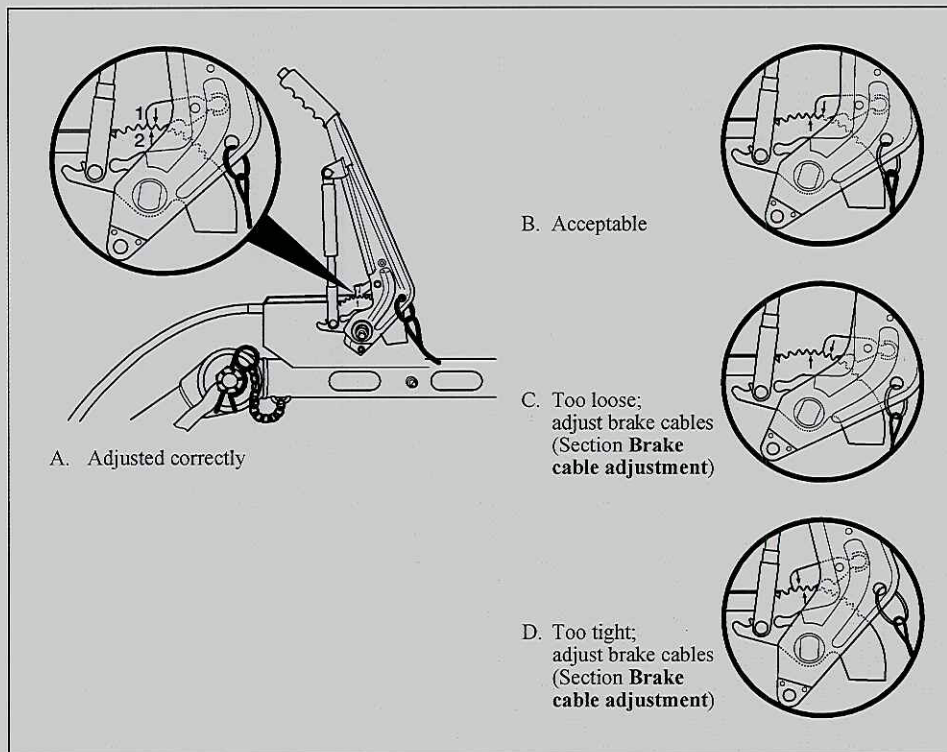

Correct and wrong position of markings

1. Check if the towing eye rod of the overrun brake mechanism is in the outmost position.
2. Check if the adjustable towbar (= option) is in the actual towing position.
3. Apply the hand brake lever.
4. Push the compressor a few centimeters backwards so that the brake lever is automatically pulled further up.
5. Check the position of the arrow marking "1" at the catch lock in combination with the arrow marking "2" at the toothed sector, according to A,B,C,D.

BRAKE CABLE ADJUSTMENT

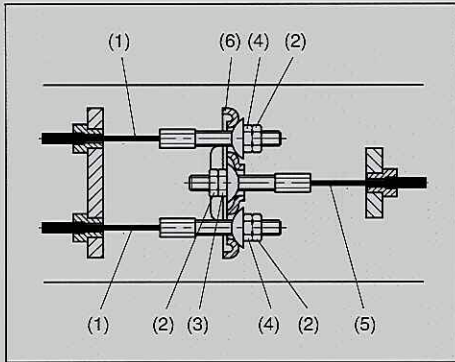

- | | |
|------------------|---------------------|
| 1. Brake cable | 4. Brake cable nut |
| 2. Lock nut | 5. Main brake cable |
| 3. Adjusting nut | 6. Equalizer |

1. With the towing eye pulled out in the outmost position and the hand brake lever in the downward position (see Figure), loosen the lock nuts (2). Turn adjusting nuts and brake cable nuts (4) clockwise until there is no slack in the brake mechanism.

The equalizer (6) must remain perpendicular to main brake cable (5).

2. Apply the hand brake lever several times and repeat the adjustment. Tighten the nuts with their lock nuts (2). Remove the jack and the blocks.
3. Road test the compressor and brake several times. Check brake shoe and brake cable adjustment and if necessary adjust.

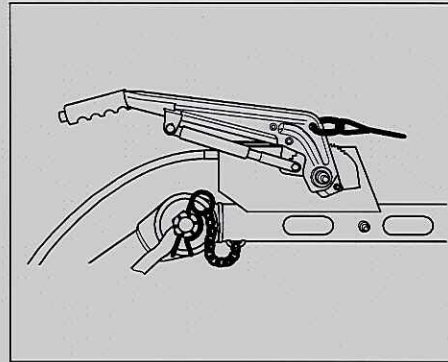

Hand brake lever downward - brake not operated

Problem solving

It is assumed that the engine is in good condition and that there is adequate fuel flow to the filter and injection equipment.

Make sure that the wires are not damaged and that they are clamped tight to their terminals.



An electrical fault must be traced by an electrician.

Problem	Possible faults	Corrective actions
1. Starter motor does not crank engine after switching startbutton (S) to "I".	a. Low battery output.	a. Check electrolyte level and charge battery. If no cells are shorted and battery is discharged, trace cause and correct.
2. Starter motor cranks engine when switching start button (S) to "I", but engine does not fire.	a. Low battery output.	a. See corrective action 1.
3. Engine fires, but engine stops when releasing start button (S).	a. Alternator drive belt broken or slipping. b. Alternator/regulator defective.	a. Check and correct if necessary. b. Have assembly repaired.
4. Hourmeter (P1) does not count running time.	a. Hourmeter (P1) defective.	a. Replace.
5. Engine is running, but shuts down immediately after start button (S) has been released.	a. Start button (S) released too soon. b. Insufficient engine oil pressure. c. Fuel tank contains insufficient fuel.	a. Release button after engine oil pressure has built up above the minimum allowed level. b. Stop at once, consult the engine instruction manual. c. Fill fuel tank.
6. Compressor is loaded automatically to full capacity after starting.	a. Air intake throttle valve stuck in opened position. b. Air leaks in regulating system.	a. Check and, if necessary consult Atlas Copco. b. Check hoses and their fittings. Stop leaks; replace leaking hoses.
7. Unit does not load after pressing the loading button.	a. Regulating valve defective.	a. Check and if necessary consult Atlas Copco.

Problem	Possible faults	Corrective actions
8. Engine does not speed up immediately after compressor loading valve button has been pressed and compressor does not deliver air.	a. Regulating valve defective. b. Air intake throttle valve stuck in closed position.	a. Check and, if necessary consult Atlas Copco. b. Check and, if necessary consult Atlas Copco.
9. Excessive compressor oil consumption. Oil mist being discharged from air outlet valves.	a. Compressor oil level too high.	a. Check oil level. Release pressure and drain oil to correct level.
10. Compressor capacity or pressure below normal.	a. Air consumption exceeds capacity of compressor. b. Choked air filter elements. c. Unloading valve not completely open.	a. Check equipment connected. b. Remove and inspect elements. c. Check and, if necessary consult Atlas Copco.
11. Compressor does not unload and engine keeps running at max. speed when closing the air outlet valves, safety valve blows.	a. Regulating valve incorrectly set or defective. b. Air leaks in regulating system. c. Unloading valve stuck.	a. Check and, if necessary consult Atlas Copco. b. Check hoses and their fittings. Stop leaks and, if necessary consult Atlas Copco. c. Check and, if necessary consult Atlas Copco.
12. Working pressure rises during operation and causes safety valve to blow.	a. Regulating valve incorrectly set or defective. b. Air leaks in regulating system. c. Unloading valve stuck. d. Safety valve defective.	a. Check and, if necessary consult Atlas Copco. b. Check hoses and their fittings. Stop leaks and, if necessary consult Atlas Copco. c. Check and, if necessary consult Atlas Copco. d. Check safety valve; consult Atlas Copco.
13. After working some time, the unit stops through a shutdown switch.	a. Fuel tank contains insufficient fuel. b. Air in fuel system, or insufficient fuel supply. c. Engine oil pressure too low. d. Engine temperature too high. e. Compressor temperature too high. f. Low coolant level.	a. Fill fuel tank. b. Check filters and hoses for leaks, dirt and bends. c. Refer to the engine instruction manual. d. See corrective actions 15. e. See corrective actions 16. f. Top up cooling system.
14. Air and oil mist expelled from air filters immediately after stopping.	a. Unloader valve jammed. b. Wrong oil type (without foam-retarding additives).	a. Check and, if necessary consult Atlas Copco. b. Consult Atlas Copco.

Problem	Possible faults	Corrective actions
15. Engine overheating.	<ul style="list-style-type: none"> a. Insufficient engine cooling. b. Engine oil cooler clogged externally. 	<ul style="list-style-type: none"> a. Relocate compressor. b. Clean engine oil cooler. Refer to section Cleaning coolers.
16. Compressor overheating.	<ul style="list-style-type: none"> a. Insufficient compressor cooling. b. Oil cooler clogged externally. c. Oil level too low. 	<ul style="list-style-type: none"> a. Locate compressor away from walls; when banked with other compressors, leave space between them. b. Clean oil cooler. Refer to section Cleaning coolers. c. Check oil level. Top up with recommended oil.
17. After working for some time, the unit stops for no apparent reason.	<ul style="list-style-type: none"> a. Air in fuel system, or insufficient fuel supply. 	<ul style="list-style-type: none"> a. Check filters and hoses for leaks, dirt and bends.

Alternator precautions

1. Never reverse the polarity of the battery or the alternator.
2. Never break any alternator or battery connections while the engine is running.
3. When recharging the battery, disconnect it from the alternator. Before using booster cables to start the engine, be sure of the polarity and connect the batteries correctly.
4. Never operate the engine without the main or voltage sensing cables connected in the circuit.

Available options

Vessel type:	EURO
	ASME
Towbar:	Adjustable with brakes (A)
	Fixed with brakes (A)
	Fixed without brakes
Without towbar:	Support (without undercarriage)
Towing eyes:	Atlas Copco
	DIN
	Ball
	Italian
	GB
	NATO
	AC (France)
Towbar support:	Support leg
	Jockey wheel
Road signalisation:	Full (B)
Safety:	Wheel chocks
	Safety cartridge
Refinery equipment:	Spark arrestor
	Inlet shut down valve

Air quality equipment:	Aftercooler + water separator
	Aftercooler + water separator + fine filter PD
	Aftercooler + water separator + fine filter DD + PD
	Aftercooler + water separator + fine filter PD + reheater (C)
	Aftercooler + water separator + fine filter DD + PD + reheater (C)
	Aftercooler + water separator + reheater
	Lubricator on 7 bar units
Cold start:	-20 °C (-4 °F)
Customer colour:	Single
	Double
	Triple

- A. These units meet your local safety regulations and are available with overrun and parking brakes.
- B. Reflectors and lights for safety on the road.
- C. Quality air through the aftercooler, reheater and fine filters.

Technical specifications

TORQUE VALUES

FOR GENERAL APPLICATIONS

The following tables list the recommended torques applied for general applications at assembly of the compressor.

For hexagon screws and nuts with strength grade 8.8

Thread size	Torque value (Nm / lbf.ft)
M6	9 (6.64)
M8	23 (16.97)
M10	46 (34.69)
M12	80 (59.04)
M14	125 (92.25)
M16	205 (151.29)

For hexagon screws and nuts with strength grade 12.9

Thread size	Torque value (Nm / lbf.ft)
M6	15 (11.07)
M8	39 (28.78)
M10	78 (57.56)
M12	135 (99.63)
M14	210 (154.98)
M16	345 (254.61)

FOR IMPORTANT ASSEMBLIES

Assemblies	Torque value (Nm / lbf.ft)
Wheel nuts	120 (88.56) +/- 15
Bolts, axle/beams	205 (151.29) +/- 20
Bolts, towbar/axle	80 (59.04) +/- 10
Bolts, towbar/bottom	205 (151.29) +/- 20
Bolts, towing eye/towbar	80 (59.04) +/- 10
Bolts, lifting eye/flywheel housing	205 (151.29) + 20
Bolts, engine/drive housing (M12)	80 (59.04) +/- 10
Bolts, engine/drive housing (M14)	125 (92.25) +/- 10
Bolts, compressor element/drive housing	80 (59.04) +/- 5
Safety switches	35 (25.83) +/- 5
Joints adjustable towbar (M24)	275 (202.95) +/- 25
Joints adjustable towbar (M32)	375 (276.75) +/- 25



Secure the drain cock and tank cap of the fuel tank handtight.

SETTINGS OF SHUTDOWN SWITCHES AND SAFETY VALVES

Designation		XA(S) 137 DD - XA(S) 300 DD7	XA(S) 137 DDG - XA(S) 300 DD7G	XAHS 107 DD - XAHS 250 DD7
Engine oil pressure	bar(e)	6	6	6
	psi	87	87	87
Engine oil temperature	°C	120	120	120
	°F	248	248	248
Compressor temperature	°C	120	120	120
	°F	248	248	248
Safety valve opening pressure				
- EC type	bar(e)	10	10	15
- ASME type	psi	150	150	218

COMPRESSOR/ENGINE/GENERATOR SPECIFICATIONS

REFERENCE CONDITIONS

Designation		XA(S) 137 DD - XA(S) 300 DD7	XA(S) 137 DDG - XA(S) 300 DD7G 230/400 V (3 phase)	XAHS 107 DD - XAHS 250 DD7
		Absolute inlet pressure	bar(e)	1
	psi	14.5	14.5	14.5
Relative air humidity	%	0	0	0
Air inlet temperature	°C	20	20	20
	°F	68	68	68
Nominal effective working pressure	bar(e)	7	7	12
	psi	102	102	174

The inlet conditions are specified at the air inlet grating outside the canopy.

LIMITATIONS

Designation			XA(S) 137 DD - XA(S) 300 DD7	XA(S) 137 DDG - XA(S) 300 DD7G 230/400 V (3 phase)	XAHS 107 DD - XAHS 250 DD7
			Minimum effective receiver pressure	bar(e)	4
	psi	58	58	58	
Maximum effective receiver pressure, compressor unloaded	bar(e)	8.5	8.5	13.5	
	psi	123	123	196	
Maximum ambient temperature at sealevel EC	standard	°C	48	48	49
		°F	118	118	120
	aftercooler option	°C	40	40	41
		°F	104	104	106
Maximum ambient temperature at sealevel NON EC	standard	°C	53	53	53
		°F	127	127	127
	aftercooler option	°C	45	45	45
		°F	113	113	113
Minimum starting temperature	°C	- 10	- 10	- 10	
	°F	14	14	14	
Minimum starting temperature, with coldstart equipment ¹⁾	°C	- 20	- 20	- 20	
	°F	- 4	- 4	- 4	
Altitude capability			see curves		

¹⁾ Compressor: PAROIL S i.s.o. PAROIL M
PAROIL 5W40 i.s.o. 15W40

Performance data

Max. allowable working pressure as a function of altitude and ambient temperature.

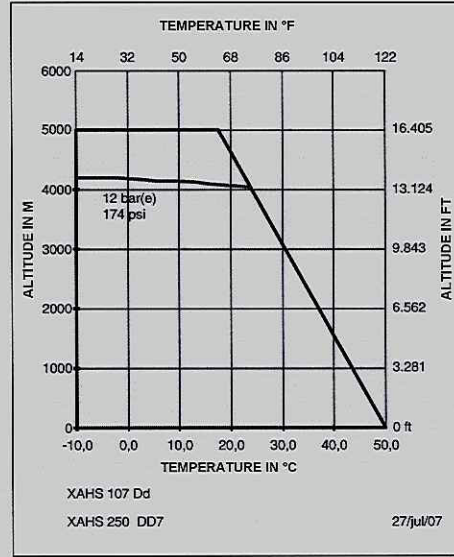
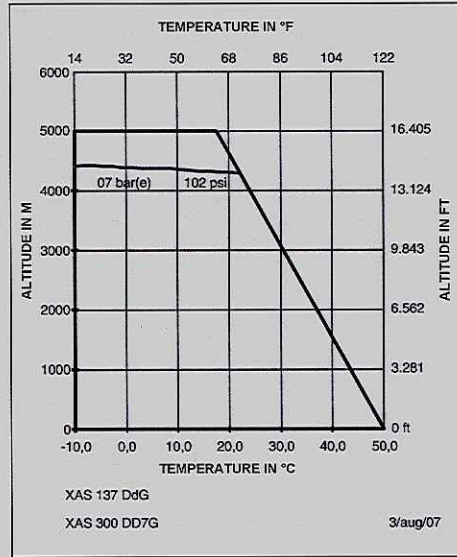
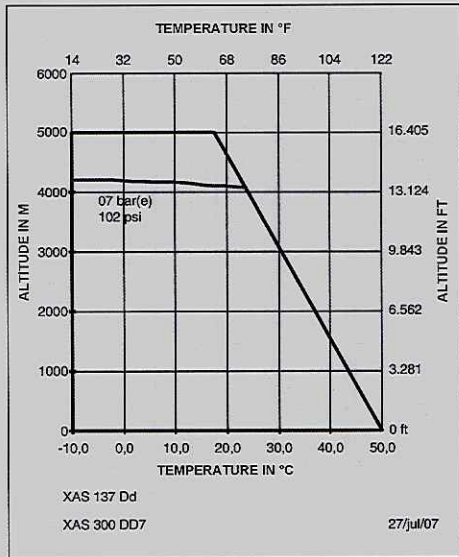

PERFORMANCE DATA

At reference conditions, if applicable, and at normal shaft speed, unless otherwise stated.

Designation			XA(S) 137 DD - XA(S) 300 DD7	XA(S) 137 DDG - XA(S) 300 DD7G 230/400 V (3 phase)	XAHS 107 DD - XAHS 250 DD7
Engine shaft speed, normal and maximum		r/min	2400	2400	2400
Engine shaft speed, compressor unloaded		r/min	1800	1700	1800
Engine shaft speed, generator at maximum load		r/min	-	2400	-
Free air delivery ¹⁾					
standard	EC	l/s	125	96	93
		cfm	265	203	197
	NON EC	l/s	127	98	95
		cfm	269	208	201
with aftercooler	EC	l/s	120	92	88
		cfm	254	195	186
	NON EC	l/s	122	94	90
		cfm	259	199	191

Fuel consumption

Designation			XA(S) 137 DD - XA(S) 300 DD7	XA(S) 137 DDG - XA(S) 300 DD7G 230/400 V (3 phase)	XAHS 107 DD - XAHS 250 DD7
at 100% FAD		kg/h	11.6	-	11.6
		lb/h	25.6	-	25.6
at 75% FAD		kg/h	9.7	-	9.7
		lb/h	21.4	-	21.4
at 50% FAD		kg/h	8.0	-	8.0
		lb/h	17.6	-	17.6
at 25% FAD		kg/h	5.7	-	5.7
		lb/h	12.6	-	12.6
at unload		kg/h	5.0	-	5.0
		lb/h	11.0	-	11.0
Specific fuel consumption					
standard	EC	g/m ³	25.8	-	34.6
		lb/10 ³ cu.ft	1.61	-	2.16
	NON EC	g/m ³	25.4	-	33.9
		lb/10 ³ cu.ft	1.58	-	2.12
with aftercooler	EC	g/m ³	26.9	-	36.6
		lb/10 ³ cu.ft	1.68	-	2.29
	NON EC	g/m ³	26.4	-	35.8
		lb/10 ³ cu.ft	1.65	-	2.24

Designation			XA(S) 137 DD - XA(S) 300 DD7	XA(S) 137 DDG - XA(S) 300 DD7G 230/400 V (3 phase)	XAHS 107 DD - XAHS 250 DD7
Typical oil content of compressed air		mg/m ³	< 5	< 5	< 5
		oz/10 ³ cft	< 0.005	< 0.005	< 0.005
Engine oil consumption (maximum)		g/h	58	58	58
		oz/h	2.05	2.05	2.05
Compressed air temperature at outlet valves	standard	°C	90	90	90
		°F	194	194	194
	with aftercooler	°C	30	30	
		°F	86	86	
Sound pressure level (Lp), measured according to ISO 2151/EPA under free field conditions at 7 m distance	ISO 2151	dB(A)	71	71	71
	EPA	dB(A)	76	76	76
Sound power level (Lw) complies with 2000/14/EC	ISO 2151	dB(A)	99	99	99
Sound power level (Lw) complies with 84/533/EEC and 85/406/EEC limits	EPA	dB(A)	104	104	104

¹⁾ Free Air Delivery (volume flow rate) is measured according to ISO 1217 ed.3 1996 annex D

Tolerance:

- +/- 5% 25 l/s (53 cfm) < FAD < 250 l/s (530 cfm)
- +/- 4% 250 l/s (530 cfm) < FAD

The international standard ISO 1217 corresponds to following national standards:

- British BSI 1571 part 1
- German DIN 1945 Part 1
- Swedish SS-ISO 1217
- American ANSI PTC9

DESIGN DATA

Compressor

Designation	
Number of compression stages	1

Engine

Designation		XA(S) 137 DD - XA(S) 300 DD7 XA(S) 137 DDG - XA(S) 300 DD7G XAHS 107 DD - XAHS 250 DD7
Make		Deutz
Type		BF4M2011
Coolant		Oil
Number of cylinders		4
Bore	mm	94
	in	3.70
Stroke	mm	112
	in	4.41
Swept volume	l	3.1
	cu.in	189.7
Output according to DIN 6271 at normal shaft speed	kW	58
	BHP	77.8
- Load factor	%	50

Designation		XA(S) 137 DD - XA(S) 300 DD7 XA(S) 137 DDG - XA(S) 300 DD7G XAHS 107 DD - XAHS 250 DD7
Capacity of oil sump:		
- Initial fill	l	11
	US gal	2.91
- Refill (max.) ¹⁾	l	6.5
	US gal	1.72

¹⁾ With filter change.

Unit

Designation	XA(S) 137 DD - XA(S) 300 DD7 XA(S) 137 DDG - XA(S) 300 DD7G XAHS 107 DD - XAHS 250 DD7	
	Capacity of compressor oil system	l
	US gal	3.43
Net capacity of air receiver	l	35
	US gal	9.25
Capacity of fuel tank	l	130
	US gal	34
Air volume at inlet grating (approx.) ¹⁾	m ³ /s	2.5
	cfm	88

¹⁾ Air required for engine and compressor cooling, for combustion and for compression.

Unit dimensions

with brakes		towbar	
		fixed	adjustable
Length	mm	3768	4278
	in	148.3	168.4
Width	mm	1676	1676
	in	66	66
Height	mm	1479	1479
	in	58.2	58.2
Weight (ready-to-operate)	kg	1500	1450
	lb	3306.9	3196.7

DESIGN DATA FOR GENERATOR

Alternator

Designation		
Standard		IEC 34-1
Make		MECC ALTE
Model		TR-2 ---/2
Rated output	kVA	12
Degree of protection	IP	23
Insulation		
- stator	class	H
- rotor	class	H
Number of phases		3
Number of leads		6

Circuit-breaker

Designation		230/400V (3 phase)
Number of poles		4
Rated current In 1ph/3ph	A	16/16
Thermal release It 1ph/3ph	A	16/32
Magnetic release Im	A	3..5 In

Electrical power circuit

Designation		230/400V (3 phase)
Rated continuous active power COP	kW	9.6
Rated power factor (lagging)		0.8
Rated continuous apparent power 3ph COP	kVA	12
Rated voltage 3ph line to line	V	400
Rated current 3ph	A	17
Rated continuous apparent power 1ph COP	kVA	
Rated voltage 1ph line to line	V	230
Rated current 1ph	A	16
Frequency droop	%	< 5

Fault current protection

Designation		230/400V (3 phase)
Insulation resistance	kOhm	13

Data plate

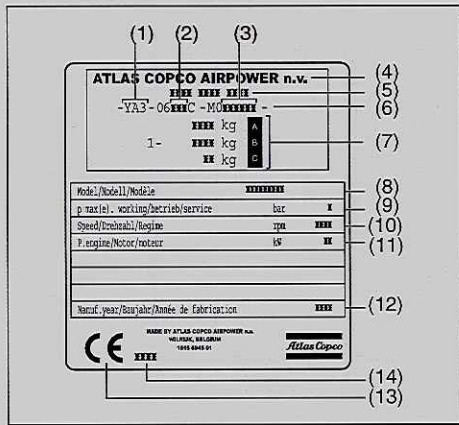

- 1 Company code
- 2 Product code
- 3 Unit serial number
- 4 Name of the manufacturer
- 5 EEC or national type approval number
- 6 Vehicle identification number
- 7 A Maximum permitted total weight of the vehicle
 B Maximum permitted axle load
 C Maximum permitted load on the towing eye
- 8 Model
- 9 Working pressure
- 10 Speed
- 11 Engine power
- 12 Manufacturing year
- 13 CE mark in accordance with Machine Directive 89/392 EC
- 14 Register number or number of notified body