

Plant #

11112

Scanned Manual #

477

Forklift Jib 2.5 ton

EAST WEST ENGINEERING

INSTRUCTION MANUAL

Type FJS & SFJS ✓
JIB ATTACHMENTS

Table of contents

	Page
1) Quality Policy Statement _____	2
2) General Description of Product _____	2
3) Method of Attachment to Forks _____	3
4) Operational and Safety Procedures _____	3
5) Risk Control Measures – Summary _____	5
6) Parts List _____	6
7) Maintenance _____	7
8) Compliance Plate Information _____	7
9) Certification Information _____	9
10) Terms and Conditions _____	10
Appendix A _____	Attached

ALL EAST WEST JIB ATTACHMENTS CONFORM TO
AS/NZS 1554.1:2000, AS 2359.1 – 1995 & AS 2359.2 – 1985

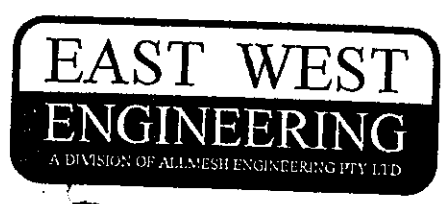

81-87 Old Pittwater Rd, Brookvale Australia
 P.O. Box 112, Brookvale NSW 2100
 Ph: (02) 9938 6944 Fax: (02) 9939 1753
 Toll Free: 1800 061 998
 Email: sales@eastwesteng.com.au

1) QUALITY POLICY STATEMENT

East West Engineering is an Australian Owned company in the Sydney suburb of Brookvale. We are Australia's leading manufacturer of forklift attachments, storage, waste containers and environmental protection equipment.

East West Engineering's products are a result of extensive market research into our customer's needs. From the first concept to engineering certification and finally, CAD/CAM manufacturing, all our designs have been rigorously researched and developed.

2) GENERAL DESCRIPTION of PRODUCT

The FJS and SFJS general-purpose Jib attachments are fitted to Industrial Trucks and are used for lifting a variety of loads. The SFJS Jib differs by having wider pocket centres than the FJS Jib. The Jib has three pin positions from closed to full extension. A locking safety chain is supplied to prevent the Jib from moving off the fork arms. They are available in either enamel paint finish 'safety yellow' or hot dip galvanised.

Manufactured strictly in accordance with AS 2359.1, the FJS and SFJS Jibs can lift loads in accordance with the Load Capacity Tables provided in *Fig. 8.3*.

Use of the FJS and SFJS Jib attachments are restricted to the purpose for which they have been designed. EAST WEST ENGINEERING is not liable if this restriction is breached.

Note: The use of the words 'Forklift' & 'Industrial Truck' throughout these instructions both refer to 'Powered Industrial Truck' as defined in AS 2359.1.

Type Data

To accurately identify the Jib attachment and when ordering parts, please quote the *Type* and *Serial Number*. This information can be found on the compliance plate situated on the base of the Outer Jib. Please refer *Fig. 8.1* and *Table 8.2*, codes "A" and "B" for more information.



WARNING: These Instructions **MUST** be **READ** in **FULL** by the Operator and all Operational & Safety Procedures and Risk Control Measures complied with before the use of this attachment.

3) METHOD of ATTACHMENT to FORKS

Before installation of the attachment onto a forklift, ensure that the fork arms are suited and set to the correct width.

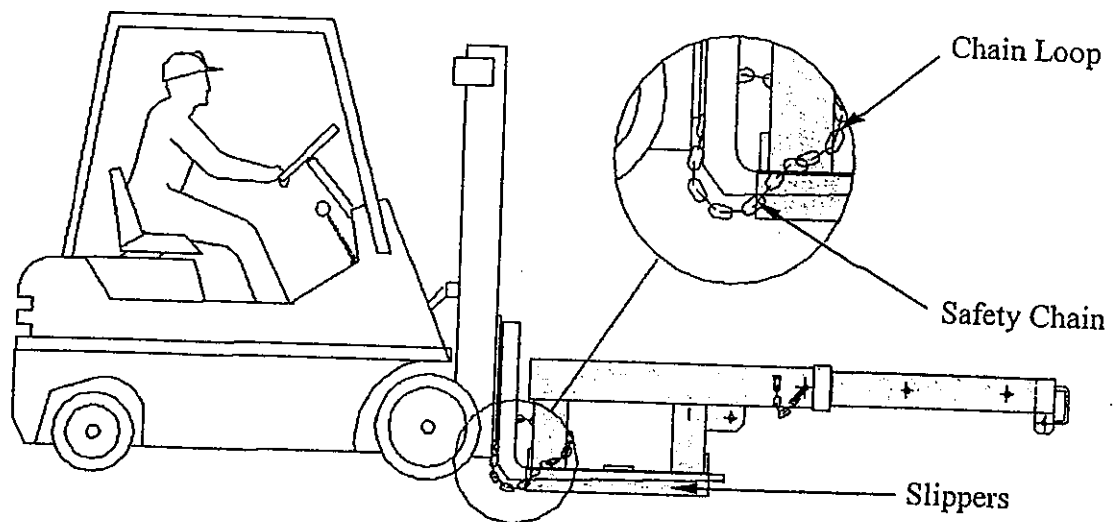

Fig. 3.1

To install the attachment, engage the forklift arm into the slippers as shown in Fig. 3.1. With the fork arm shank (vertical face) firmly against the rear of attachment, run the safety chain provided around the carriage or tower. Re-attach the chain to the chain loop at the base of the Jib.



WARNING: In accordance with Australian Standard AS2359.6, the following attachment information shall be added to the manufacturer's "Identification Plate" on the Industrial Truck;

- type of attachment,
- weight of unladen truck in working condition fitted with attachment,
- Capacity of truck and attachment combination at maximum elevation.

4) OPERATIONAL and SAFETY PROCEDURES

Preliminary Safety Checks

A "Competent Person" shall check the following;

- (1) that all locating pins are correctly positioned and are in safe working order and safety clipped,
- (2) that the Jib hook assembly is correctly fitted and in safe working order,
- (3) that the safety chains are in good condition,
- (4) that the shackle securing the swivel hook is correctly installed and tightened.

The Operator shall check that the attachment has been correctly fitted in accordance with these Instructions (refer Section 3), and/or the relevant Industrial Truck Operator's Manual. The Operator shall consult the load tables provided and ensure that the industrial truck or attachment lift capacity is not exceeded. Refer *Fig. 8.3*.

All signage must be strictly adhered to and ensure that the compliance plate is not damaged and is clearly legible.

General Operating and Safety Procedures

To extend the Jib remove the safety clip and withdraw the locking pin, select the preferred extension, then reinsert the locking pin through the outer and Inner Jib sections. Reinsert the safety clip.

Handling suspended loads by an attachment can introduce dynamic loads affecting stability. Sudden stops, starts and turns can cause the load to swing and create a hazard.

Forklift attachments can alter load centres and reduce the load capacity. The type of load to be handled in addition to the operating conditions must be considered when determining the actual working capacity for each application. Do not exceed the recommended forklift or attachment rating.

When lifting with a Jib attachment the net lifting capacity should be 0.8 times the rating of the truck.



WARNING: Any SWL noted on the attachment is a structural rating of the attachment only and makes no claim to the suitability of the forklift. Actual load may be restricted to the suitability of the forklift. Actual lift truck capacities must be obtained from the lift truck manufacturer.

East West Engineering attachments shall not be modified in any way which affects the operation or performance except with the prior approval of East West Engineering. After any changes have been effected, appropriate alterations shall be made on the relevant nameplate and markings prior to placing the attachment back into service. East West Engineering must be notified of the changes to nameplates and markings with reference to the attachment serial number.

5) RISK CONTROL MEASURES – SUMMARY

When handling loads, the following Risk Control Measures are to be observed by the operator to ensure all identified hazards relative to using this equipment are eliminated or controlled – refer Appendix A for a detailed analysis;

- A) The Industrial Truck Operator requires a suitable forklift licence to cover both the Industrial Truck being operated and the attachment that has been fitted. Training in the safe use of the attachment and the use of lifting booms, slings and chains for lifting shall be undertaken before usage.
- B) Authorised personnel must perform the following pre-checks immediately prior to the use of the Industrial Truck in accordance with AS 2359.2 Clause 3.1 and 6.4 and corrective action initiated where applicable;
 - Nameplate and markings regarding the Industrial Truck and Attachment capacities are to be read and acknowledged,
 - Condition of lift and tilt systems on the Industrial Truck to be checked,
 - Inspect all tyres for wear, condition and pressure if applicable,
 - Liquid levels of battery cell electrolyte, oils (hydraulic, engine, transmission and brake), cooling water and fuel to be checked,
 - All steering and brake controls, warning devices and lights to be checked for effective operation.
- C) Gain assurance from a responsible person that the load may be handled safely with an attachment and that person has provided all information necessary to ensure that risks are eliminated or controlled.
- D) Do not exceed the rated capacity of the Industrial Truck to handle the load.
- E) The Industrial Trucks shall be used on a hard level surface. The area in which the attachment is to be used has been accessed as suitable for the task to be undertaken. There should be suitable clear space to safely use the attachment and a system developed for handling the load.
- F) While lifting in an area subject to passing traffic, barriers or warning signs shall be used to prevent any interference.
- G) Manoeuvre slowly and cautiously when the load is elevated.
- H) Transport the load with the attachment positioned as low as practicable.
- I) The mast, if adjustable shall be set at vertical or back tilted.
- J) Never drag the load horizontally along the ground.
- K) The Operator shall check the attachment is securely attached, refer *Fig. 3.1*.
- L) The Operator shall stay with the Industrial Truck controls at all times.
- M) The Operator shall keep hands and feet clear of controls other than controls in use.
- N) The Operator shall keep clear of overhead obstructions and in particular **MAINTAIN RELEVANT CLEARANCE OF ELECTRICAL CONDUCTORS.**
- O) Before any load is hoisted by the attachment, the Operator shall lift the attachment unladen to the required working height to confirm that all systems are functioning correctly.
- P) Ensure safety features are provided, visible and working effectively.

- Q) Ensure there has been no unauthorised interference or alteration to the plant that may cause risk.
- R) Ensure regular maintenance, testing and inspections are carried out and recorded in accordance with the relevant Industrial Truck Manuals and these instructions (refer Section 7), and corrective action initiated where applicable.
- S) Ensure the instructions of East West Engineering are followed.
- T) If any of the equipment becomes unsafe, stop all usage until the risk is eliminated or controlled.

WARNING: Failure to observe the above Risk Control Measures and those outlined in Appendix A could result in **SERIOUS INJURY** or **DEATH**.

6) PARTS LIST

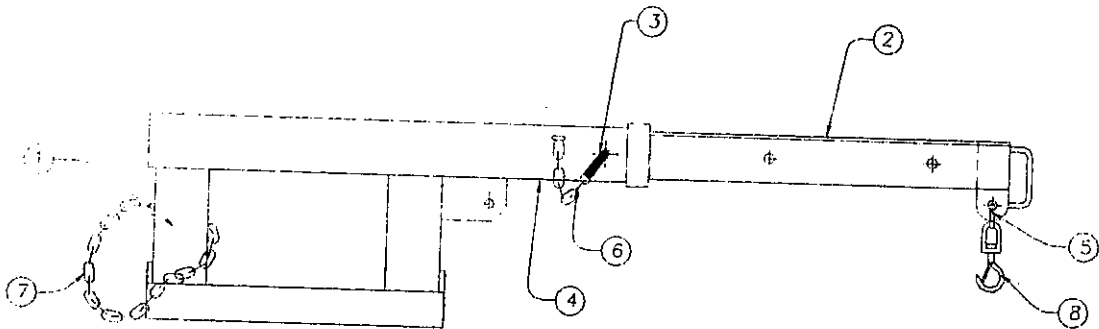

Fig. 6.1

Item	Description	FJS 2.5 Part No	FJS 5 Part No	SFJS 2.5 Part No	SFJS 5 Part No	SFJS 7.5 Part No	SFJS 10 Part No
1	Outer Jib	FJS2.5-02	FJS5-02	SFJS2.5-02	SFJS5-02	SFJS7.5-02	SFJS10-02
2	Inner Jib	FJS2.5-03	FJS5-03	FJS2.5-03	FJS5-03	FJS7.5-03	FJS10-03
3	Locking Pin	SP-0004	SP-0004	SP-0004	SP-0004	SP-0145	SP-0002
4	Slide Packer	SP-0008	SP-0009	SP-0008	SP-0009	SP-0011	N/A
5	Shackle	3.2 T	4.75 T	3.2 T	4.75 T	8.5 T	12 T
6	Jib Chain Assembly	SP-0150	SP-0150	SP-0150	SP-0150	SP-0150	SP-0150
7	Rear Chain Assembly	SP-0105	SP-0105	SP-0105	SP-0105	SP-0105	SP-0105
8	Lifting Hook	SVH0300	SVH0475	SVH0300	SVH0475	8.0 T	SVH1100

Table 6.2

7) MAINTENANCE

Regular maintenance including Testing, Inspection and Cleaning should be carried out on the Jib to reduce the risk of potential hazards arising. The Jib should be cleaned and visually inspected by a "Competent Person" under adequate lighting conditions, before each shift, to ensure all components are functioning correctly and are free from any noticeable wear or damage, particularly at any load-bearing or highly stressed points. If components are considered worn or damaged, or if safety charts or labels are damaged or illegible, the Jib should be taken out of service and East West Engineering or an "Authorised Person" contacted for advice. Periodic testing may be required if any damage is noted as this could be an indication of abuse or overloading. Regular cleaning makes identification of damage easier. Keep maintenance records to ensure safety checks are carried out.

Maintenance Schedule

Item Description	Maintenance Period					
	Daily or 8 Hrs	Weekly or 40 Hrs	Monthly or 160 Hrs	3 Months or 500 Hrs	Annually or 2000 Hrs	Other
Safety Chains	CI					
Lifting Hooks	CI					
Locking Pins & Chains	CI					

Table 7.1

Maintenance to be carried out		
Maintenance Codes		Lubricant to be used
GS = Grease smear	D = Drain	G = Grease, Shell Alvania R2 or equivalent
GN = Grease at nipple	R = Replace	H = Hydraulic Oil Shell Tellus
CI = Clean and inspect	T = Tighten	Ot = Oil, Shell 20W/40W or equivalent
C = Check & fill oil to level	N = Note below	Oa = Oil, Shell Turbo T32 or equivalent

Table 7.2

8) COMPLIANCE PLATE INFORMATION

EAST WEST ENGINEERING			
81-87 OLD PITWATER RD, BROOKVALE NSW AUSTRALIA PHONE: (02) 9938 6944 FAX: (02) 9939 1753			
TYPE	"A"	WEIGHT	"D" kg
No.	"B"	H C G	"E" mm
SWL	"C" kg	LOAD CT.	"F" mm
● ACTUAL LOAD MAY BE RESTRICTED BY THE CAPACITY OF THE FORKLIFT ●			

Fig. 8.1

A	Product Type	Refer "A", Table 8.2
B	Serial Number	Individually stamped
C	Safe Working Load	Refer "C", Table 8.2
D	Dry Weight of the unit	Refer "D", Table 8.2
E	Horizontal C of G	Refer "E", Table 8.2
F	Load Centre	Refer "F", Table 8.2

COMPLIANCE PLATE MARKING						
Type	"A"	"B"	"C"	"D"	"E"	"F"
FJS 2.5	FJS 2.5	SERIAL No	2500	100	700	800
FJS 5	FJS 5	SERIAL No	4750	130	700	800
SFJS 2.5	SFJS 2.5	SERIAL No	2500	125	650	800
SFJS 5	SFJS 5	SERIAL No	4750	160	650	800
SFJS 7.5	SFJS 7.5	SERIAL No	7500	320	740	800
SFJS 10	SFJS 10	SERIAL No	10,000	400	740	800

Table 8.2

Load Capacity Tables

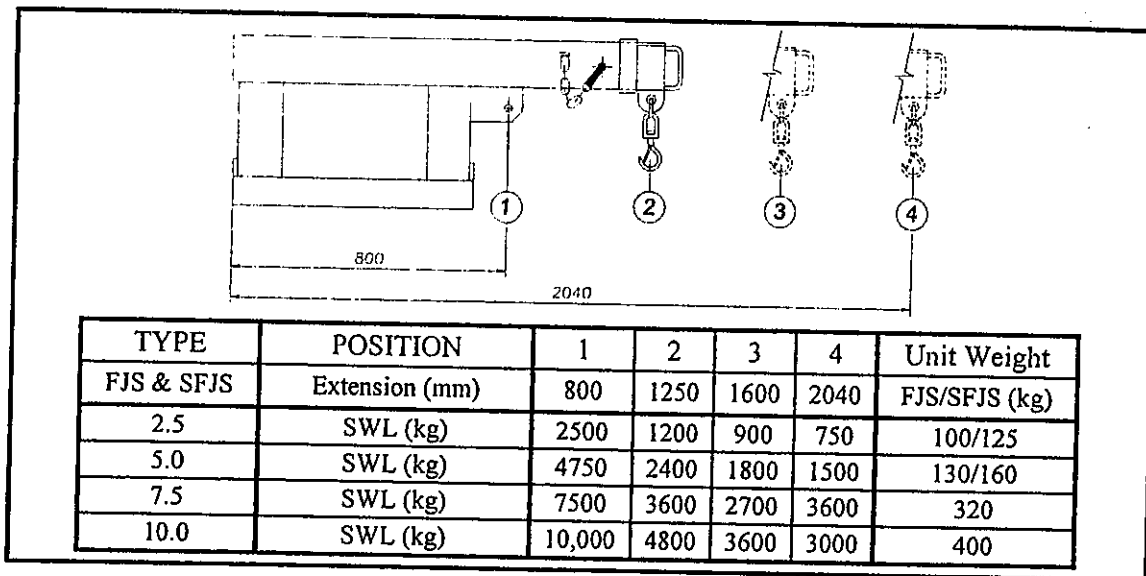

Fig. 8.3

The Load capacity tables (refer Fig. 8.3) and compliance plate (refer Fig. 8.1) must be legible and clearly visible. If damage occurs, contact East West Engineering for a replacement part.

9) CERTIFICATION INFORMATION

Certificate

FJS and SFJS Jib Attachments

We certify that the type FJS and SFJS Jib Attachments are rated to the Safe Working Load (SWL) shown on their Compliance Plate and are designed and fabricated strictly in accordance with relevant Australian Standards including those listed below –

AS/NZS 1554.1: 2000	Structural Steel Welding – Welding of Steel Structures
AS 2359.1 – 1995	Powered Industrial Trucks – General Requirements
AS 2359.2 – 1985	SAA Industrial Truck Code – Operation
AS 3990 – 1993	Mechanical Equipment – Steelwork
AS/NZS 4680: 1999	Hot Dip Galvanised (Zinc) Coatings on Fabricated Ferrous Articles

Signed on behalf of EAST WEST ENGINEERING,



Ron King
MANAGING DIRECTOR

10) TERMS of TRADE, CONDITIONS of SALE and WARRANTY STATEMENT

1. East West Engineering (EWE) products are to be used only as indicated. Misuse or misapplication may cause failure resulting in possible property damage or bodily injury.
2. It is the obligation of the user to ensure EWE products are used in accordance with appropriate Codes and System requirements.
3. All liability for EWE products performance is disclaimed and the warranty will be voided if any of the following conditions exist:
 - 3.1) The product is used beyond the published or stated rate load limit. Note: ALL ratings are for static conditions and do not account for dynamic loading such as wind, water or seismic loads.
 - 3.2) The product is not properly installed per published or stated instructions
 - 3.3) The loading to the product is not vertical
 - 3.4) The product is deformed or stressed in any way during fitting or installation.
 - 3.5) The product is used in a corrosive environment.
4. All safety regulations required by the user must be observed.
5. EWE products at the time of dispatch are warranted to be free of defects in material or workmanship. **NO OTHER WARRANTY EXPRESSED OR IMPLIED SHALL EXIST IN CONNECTION WITH THE SALE OR USE OF EWE PRODUCTS.** Claims for errors, shortages, defects or non-conformities ascertainable upon inspection must be made in writing within 15 days after buyer's receipt of products. All other claims must be made to EWE within 12 months of the date of shipment for products hydraulically operated and within 12 months for products without hydraulics. Products claimed nonconforming or defective must upon EWE's request promptly be returned for inspection. Claims not made as provided above and within the applicable time period will be barred. EWE shall in no event be responsible if the products have not been used in accordance with the specifications and/or recommended procedures. EWE will, at its option either repair or replace nonconforming or defective products for which it is responsible or return to buyer their purchase price. The foregoing states buyer's exclusive remedy for any breach of EWE warranty and for any claim, whether sounding in contracts, tort or negligence for loss or injury caused by the sale or use of any product. Without limiting the generality of the foregoing EWE shall in no way be responsible for any loss of business or profits, downtime or delay, labour, repair or material cost or any similar or dissimilar consequential loss or damage incurred by the Buyer.
6. Examine goods immediately upon receipt and advise any damage or shortage to carriers and ourselves within 15 days, otherwise no claim whatever will be considered. Provided advice is given within the prescribed time, we will make good any shortage and will repair or replace free of charge goods damaged in transit where we are responsible for delivery of the goods.
7. If goods are not received within 14 days from receipt of invoice please advise us in writing.
8. If any error is discovered in this invoicing please notify supplying branch at once for correction.
9. **Property and Payment:** – By acceptance of delivery and retention of the goods it is acknowledged that the property of the goods remains with EWE and that legal title thereto will not pass until payment is made but that nevertheless the goods are at your risk after delivery. In the event that payment is not made within 30 days of delivery, or other agreed terms, full licence and authority is given to EWE to enter any premises where the goods are stored and to recover possession of them. In the event of the sale of the goods prior to payment, the proceeds of sale belong to EWE.
10. **Terms of Payment:** – Unless credit has been arranged strictly net cash; if credit has been arranged payment must be made by the 25th day of the month, following the month appearing in the date on the front of this invoice.
11. East West Engineering reserves the right to alter specifications, designs and prices without notification.

Appendix A – to form Part of the Instruction Manual Risk Control Measures & Risk Assessment for Identified Hazards



Equipment Type & Description: FJS & SFJS Fixed Jib Attachments

Sheet: 1 of 8

Operation	Hazards Identified	Risk Assessment	Risk Control Measures in Place	Risk Control In Place (Date)
1. Industrial Truck Operational Safety Pre-Checks.	a) Unsafe use of Industrial Truck resulting in Attachment/Load shifting, falling, striking Pedestrians and/or objects.	<ul style="list-style-type: none"> • Serious Risk to Operator. • Serious Risk to Pedestrians. 	<ul style="list-style-type: none"> - Pre-operational inspections (in accordance with AS 2359.2), to be carried out before each shift - Industrial Truck taken out of service if any risks or malfunctions are found. These MUST be reported & recorded for assessment by a competent person. - The operational areas to be assessed for hazards prior to and during work shifts. - The Industrial Truck to be left in a safe condition after each shift. - Inspections, maintenance and repairs to be carried out in accordance with the relative Industrial Truck Operating Manuals and AS 2359.2. - If more than 25 persons employed at workplace/site, a Certified First Aider to be at Workplace or on Site. 	

Assessment carried out by: _____

Allan WALKER, East West Engineering

Date of Assessment: _____

20th October 2003

Appendix A -- to form Part of the Instruction Manual

Risk Control Measures & Risk Assessment for Identified Hazards



Equipment Type & Description: FJS & SFJS Fixed Jib Attachments

Sheet: 2 of 8

Operation	Hazards Identified	Risk Assessment	Risk Control Measures in Place	Risk Control In Place (Date)
2. Attachment Operational Safety Pre-Checks.	a) Attachment /Load shifting, falling, striking Pedestrians and/or objects.	<ul style="list-style-type: none"> • Serious Risk to Pedestrians. • Moderate Risk to Operator. 	<ul style="list-style-type: none"> - Inspections, maintenance and repairs to be carried out in accordance with Instruction Manual. - All Pre-Checks listed in the Instruction Manual are to be carried out before each shift. - The attachment is to be fitted securely to the lifting apparatus according to the Instruction Manual. - All instructions for the use of the attachment as laid out in the Instruction manual are to be followed. - The use of the attachment is limited to those situations for which it is specifically designed and in accordance with AS 2359.1 where applicable. 	

Assessment carried out by: Allan WALKER, East West Engineering

Date of Assessment: 20th October 2003

Appendix A – to form Part of the Instruction Manual

Risk Control Measures & Risk Assessment for Identified Hazards



Equipment Type & Description: FJS & SFJS Fixed Jib Attachments

Sheet: 3 of 8

Operation	Hazards Identified	Risk Assessment	Risk Control Measures in Place	Risk Control In Place (Date)
3. Lifting & lowering Attachment and Load.	a) Unsafe/Incompetent Operator.	<ul style="list-style-type: none"> • Serious Risk to Operator. • Serious Risk to Pedestrians. 	<ul style="list-style-type: none"> - Only Certified & fully Trained Operators are to use equipment. 	
	b) Items Falling from Height.	<ul style="list-style-type: none"> • Serious Risk to Pedestrians. • Moderate Risk to Operator. 	<ul style="list-style-type: none"> - The attachment is to be fitted securely to the lifting apparatus. - All safety chains, locking pins & safety clips are to be installed correctly. - Barriers/warning Signs in areas subject to passing traffic to be installed. - The attachment/load to be raised no higher than necessary. - The Industrial Truck mast, if adjustable, to be back tilted. - The attachment is NOT to be dragged along the ground. - The attachment is to be transported as low as practicable. 	

Assessment carried out by: Allan WALKER, East West Engineering Date of Assessment: 20th October 2003

Appendix A – to form Part of the Instruction Manual

Risk Control Measures & Risk Assessment for Identified Hazards



Equipment Type & Description: FJS & SFJS Fixed Jib Attachments Sheet: 4 of 8

Operation	Hazards Identified	Risk Assessment	Risk Control Measures in Place	Risk Control In Place (Date)
3. Lifting & lowering Attachment and Load. (continued)	c) Load too heavy and/or unbalanced – Industrial Truck overturning.	<ul style="list-style-type: none"> • Serious Risk to Pedestrians. • Serious Risk to Operator. 	<ul style="list-style-type: none"> - All Risk Control Measures outlined in 3(b) above are to be in place. - The Operator to be aware of the weight of attachment & load. - Operator to gain assurance from a responsible person that the load may be handled safely. - Operator to be trained in the use of lifting booms, slings & chains for lifting loads. - The rating capacity of the Industrial Truck to handle the load is NOT to be exceeded. - The Industrial Truck to be used only on a hard level surface, the area assessed before usage. - The attachment to be raised unladen to working height to confirm all systems are functioning. 	

Assessment carried out by: Allan WALKER, East West Engineering Date of Assessment: 20th October 2003

Appendix A – to form Part of the Instruction Manual Risk Control Measures & Risk Assessment for Identified Hazards



Equipment Type & Description: FJS & SFJS Fixed Jib Attachments

Sheet: 5 of 8

Operation	Hazards Identified	Risk Assessment	Risk Control Measures in Place	Risk Control In Place (Date)
3. Lifting & lowering Attachment and Load. (continued)	d) Industrial Truck /Attachment striking Pedestrians.	<ul style="list-style-type: none"> • Serious Risk to Pedestrians. 	<ul style="list-style-type: none"> - All Risk Control Measures outlined in 3(b) above are to be in place. - A suitable clear space between barriers to be left to safely use the attachment. - The Inner Jib is to be extended no further than necessary. 	
	e) Industrial Truck Mast striking overhead fittings.	<ul style="list-style-type: none"> • Serious Risk to Operator. • Serious Risk to Pedestrians. 	<ul style="list-style-type: none"> - Work areas to be assessed to ensure NO overhead fittings can be contacted by mast, attachment, or load. - Industrial Truck to keep clear of any overhead obstructions especially ELECTRICAL conductors. 	

Assessment carried out by: Allan WALKER, East West Engineering Date of Assessment: 20th October 2003

Appendix A – to form Part of the Instruction Manual

Risk Control Measures & Risk Assessment for Identified Hazards



Equipment Type & Description: FJS & SFJS Fixed Jib Attachments

Sheet: 6 of 8

Operation	Hazards Identified	Risk Assessment	Risk Control Measures in Place	Risk Control In Place (Date)
4. Transporting loads with attachment about the Workplace or Site.	a) Load Shifting/Falling.	<ul style="list-style-type: none"> • Serious Risk to Pedestrians. • Moderate Risk to Operator. 	<ul style="list-style-type: none"> - All Risk Control Measures outlined in 3(b) and 3(c) above are to be in place. - The Operator to check the Load is secured to the Attachment and prevented from swinging. 	
	b) Industrial Truck /Attachment striking Pedestrians.	<ul style="list-style-type: none"> • Serious Risk to Pedestrians. 	<ul style="list-style-type: none"> - All Risk Control Measures outlined in 3(d) above are to be in place. - A system is to be developed for handling the Loads about the Workplace/Site. - Convex mirrors are to be placed at Aisle corners in areas used by Industrial Trucks. - All safety equipment on the Industrial Truck MUST be functioning before use, (ie Reversing Beepers) - Manoeuvre slowly & cautiously when Loads are elevated. 	

Assessment carried out by: Allan WALKER, East West Engineering Date of Assessment: 20th October 2003

Appendix A – to form Part of the Instruction Manual Risk Control Measures & Risk Assessment for Identified Hazards



Equipment Type & Description: FJS & SFJS Fixed Jib Attachments

Sheet: 7 of 8

Operation	Hazards Identified	Risk Assessment	Risk Control Measures in Place	Risk Control In Place (Date)
4. Transporting loads with attachment about the Workplace or Site. (continued)	c) Operator exposed to fixed/moving components.	<ul style="list-style-type: none"> • Serious Risk to Operator. 	<ul style="list-style-type: none"> - The Operator is to stay with the Industrial Truck controls at all times whilst in operation. - The Operator is to keep hands/feet wholly within Industrial Truck cab whilst in operation. 	
	d) Industrial Truck /Attachment striking obstacles.	<ul style="list-style-type: none"> • Serious Risk to Operator. 	<ul style="list-style-type: none"> - All Risk Control Measures outlined in 3(e), 4(b) and 4(c) above are to be in place. 	
	e) Industrial Truck /Attachment falling from raised areas.	<ul style="list-style-type: none"> • Serious Risk to Operator. • Serious Risk to Pedestrians. 	<ul style="list-style-type: none"> - All Risk Control Measures outlined in 4(b) and 4(c) above are to be in place. - All safety railings are to be placed in raised areas such as Ramps, Loading Docks etc. 	

Assessment carried out by: Allan WALKER, East West Engineering

Date of Assessment: 20th October 2003

Appendix A – to form Part of the Instruction Manual

Risk Control Measures & Risk Assessment for Identified Hazards



Equipment Type & Description: FJS & SFJS Fixed Jib Attachments Sheet: 8 of 8

Operation	Hazards Identified	Risk Assessment	Risk Control Measures in Place	Risk Control In Place (Date)
5. Storage of Attachment.	<p>a) Attachment becoming damaged.</p> <p>b) Attachment in the way of normal Workplace/Site Operations.</p>	<ul style="list-style-type: none"> • Serious Risk to Pedestrians. • Moderate Risk to Operator. • Moderate Risk to Pedestrians. 	<ul style="list-style-type: none"> - Regular Maintenance, inspection and testing according to the Instruction Manual to be carried out. - Attachment to be stored in dry areas and away from any corrosive chemicals. - Attachment to be stored in areas which will not interfere with the normal running of the Workplace/Site. 	

Assessment carried out by: Allan WALKER, East West Engineering Date of Assessment: 20th October 2003