



Edition : 3.0
Date: (10/24)

Instruction Manual

MOBILE GIRDER RAILGANTRY MGT-1T

Order Code: (C188)

MACHINE DETAILS

MACHINE

MOBILE GIRDER RAIL GANTRY

MODEL NO.

MGT-1T

SERIAL NO.

DATE OF MANF.



NOTE:

In order to see the type and model of the machine, please see the specification plate. Usually found on the back of the machine. See example (Fig.1)

	
PRODUCT SPECIFICATIONS	
Model: MGT-1T	Nett Weight: 142kg
Capacity: WLL 1000Kg	MFG Date:
Serial No:	<input type="text"/>
Made in China	

(Fig.1)



WARNING

This gantry has been tested to ensure that the capacity listed in the specification can safely be lifted. DO NOT exceed the capacity under any circumstance. Exceeding the capacity will void the warranty and may cause injury or death

Order Code	C188
MODEL	MGT-1T
Load Capacity	1 Tonne
Adjustable Beam Height (min. / max.)	2540 – 3600mm
Inside Frame Clearance	2300mm
Outside Frame Width	2600mm
I-Beam Width	76mm
Nett Weight	142kg

GENERAL WORKSHOP SAFETY

DO NOT use this machine unless you have read this manual or have been instructed in the use of this machine in its safe use and operation



WARNING

This manual provides safety instructions on the proper setup, operation, maintenance, and service of this machine. Save this manual, refer to it often, and use it to instruct other operators. Failure to read, understand and follow the instructions in this manual may result in serious personal injury — including amputation, or death.

The owner of this machine is solely responsible for its safe use. This responsibility includes, but is not limited to proper installation in a safe environment, personnel training and authorization to use, proper inspection and maintenance, manual availability and comprehension, of the application of the safety devices, integrity, and the use of personal protective equipment.

The manufacturer will not be held liable for injury or property damage from negligence, improper training, machine modifications or misuse.

GENERAL WORKSHOP SAFETY Cont.



Safety glasses must be worn at all times in work areas. Earmuffs should be worn if the work area is noisy.



Gloves should NOT be worn when operating powered machines



Sturdy footwear must be worn at all times in work areas.



Long and loose hair must be contained with a net or under a hat

OWNER'S MANUAL. Read and understand this owner's manual before using the machine.

CHECK DAMAGED PARTS. Regularly inspect the machine for any condition that may affect the safe operation. Immediately repair or replace damaged or parts that are incorrectly fitted before operating.

WEARING PROPER APPAREL Do not wear clothing, apparel or jewelry that can become entangled in moving parts. Always tie back or cover long hair. Wear non-slip footwear to avoid accidental slips, which could cause loss of operating control.

HEARING PROTECTION. Always wear hearing protection when operating or observing loud machinery. Extended exposure to this noise without hearing protection can cause permanent hearing loss.

USE CORRECT TOOL FOR THE JOB. Only use this tool for its intended purpose. Do not force the machine or its attachments to do a job for which they were not designed. Never make unapproved modifications. Modifying the machine or using it differently than intended may result in malfunction or mechanical failure that can lead to personal injury or death!

AWKWARD POSITIONS. Keep proper footing and balance at all times when operating the machine. Do not overreach! Avoid awkward hand positions that make operating control difficult. This could increase the risk of accidental injury.

TRAINED OPERATORS ONLY. Operators that have not been trained have a higher risk of being seriously injured. Only allow trained or supervised people to use this machine. When the machine is not being used, disconnect the power, to the machine to prevent unauthorized use—especially around children. Make the workshop safe.

FORCING MACHINERY. Do not force the machine. It will do the job safer and better at the rate for which it was designed.

NEVER STAND ON MACHINE. Serious injury may occur if the machine is tipped or if crush points are unintentionally contacted

STABLE MACHINE. Unexpected movement during operation greatly increases risk of injury or loss of control. Before using the machine, verify that it is stable

UNATTENDED OPERATION. To reduce the risk of accidental injury, never leave the machine in use while unattended.

MAINTAIN WITH CARE. Follow all maintenance instructions and lubrication schedules to keep the machine in good working condition. A machine that is improperly maintained could malfunction, leading to serious personal injury or death.

CHILDREN & BYSTANDERS. Keep children and bystanders at a safe distance from the work area. Stop using machine if they become a distraction.

SPECIFIC SAFETY FOR MOBILE GANTRY

DO NOT use this machine unless you have read the manual or have been trained and assessed to a competent level in its safe use and operation.



Safety glasses must be worn when operating this equipment



Long and loose hair must be contained when operating this equipment.



Safety footwear must be worn when operating this equipment



Close fitting/protective clothing must be worn when operating the machine

When Using Mobile Gantries Never:

- Attempt to move a gantry whilst under load.
- Use a vehicle, winch etc to tow a gantry.
- Allow the load to swing unduly or in an uncontrolled manner.
- Rotate loads unless the centre of gravity will remain under the centre line of the runway beam.
- Allow persons to pass under suspended loads.
- Place ladders or climb on unrestrained gantries.

Installing and Commissioning

Follow the specific instructions for erection issued by the supplier as these will vary with the design. Never force or hammer bolts, locking pins etc into place. Damaged or lost bolts, nuts washers etc must only be replaced with identical items of the same grade and size. Never place ladders or climb on unrestrained gantries.

Using Mobile Gantries Safely

- Do not use defective gantries, blocks or accessories.
- Inspect the gantry to ensure it is correctly erected and that all bolts, pins etc are correctly in place.
- Position the gantry carefully aligning the runway track with the direction of load travel. The block hook must be directly over the centre of gravity of the load. The standing area must be level and capable of sustaining the imposed loads. Where necessary use floor plates to achieve this. Caution must be exercised to avoid hidden dangers such as buried cables, pipes etc.
- Ensure the gantry remains stable during lifting operations. If fitted, jacks should be in contact with the floor, brakes applied or wheel locks in position.
- Do not attempt to move a gantry whilst under load.
- Avoid swinging loads. The centre of gravity of the load should always be under the runway centre line.
- Ensure power supply leads etc are disconnected before moving the gantry to a new position.

In-service Inspection and Maintenance

The maintenance requirements may be combined with those of the lifting appliance. Bearings and screw jacks should be lubricated. The running surface of the track should be clean and free of debris etc. Regularly inspect the gantry and, in the event of the following defects, refer the gantry to a Competent Person for thorough examination: structural defects, damage, distortion or cracked welds; loose or missing bolts, locking pins etc; damaged wheels, jacks or ineffective brakes; damaged or missing runway end stops; any other visible defects.

ASSEMBLY

The machine must be fully assembled before it can be operated. First clean any parts that are coated in rust preventative to ensure the assembly process can proceed smoothly.

Note! DO NOT attempt to assemble the gantry without the help of at least two other people.

To Assemble The Gantry:

1. Un-pack and layout the parts of the Mobile Gantry on a clear area of floor, the

NOTE: Save all the packaging materials until you are completely satisfied with the machine and have resolved any issues with the distributor, or the shipping agent.

2. Attach the casters to the horizontal base plates using the M10 x 30mm Bolts, washers and spring washers. (Fig. 2)

Note! When putting nuts and bolts together on Lifting equipment, it is a good practice to put bolt up from underneath and nut on top. This way if nut comes loose, bolt falls out and it will be noticed missing .



Fig. 2

3. Attach the upright post with M12 x 100mm bolts, washers, spring washers and nuts, and braces using M14 x 40 Bolts, washer spring washer and nut to the horizontal base plates. (Fig. 3)



Fig. 3

4. Support the I-Beam on an angle and attach one of the up-rights using the M12 x 35 bolt, washer, spring washer and nut. (Fig. 4)

Note! Make sure the casters have been locked before attaching the up-right.



Fig. 4

5. Lift the I-Beam with a chain block and secure. Attach the other up-right. (Fig. 5)



Fig. 5

ASSEMBLY STEP BY STEP

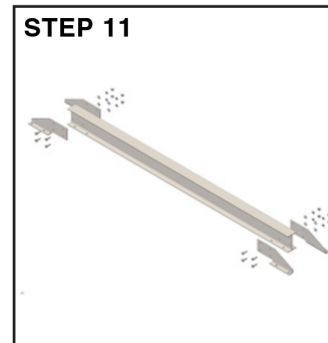

OPERATION

The **HAFCO MGT-1T** Mobile Gantry is fitted with a height adjusting Ratchet System. The manufacturer recommends that when adjusting the height that this action should be a Two man operation – one on each end of the gantry, working together. Gloves should always be worn when using the gantry.

To Raise The Height Of the Gantry

1. Decide the height that is required, making sure to use the lowest height possible.
2. Make sure that the claw-hook that is attached to the end of ratchet lever is securely under the bottom pin in the hole on the end frame upright. (Fig. 6)
3. Tension the ratchet lever to take the upright/ beam weight.
4. Remove the upper pin on pin plate. (Fig. 7)
5. Operate the ratchet lever to adjust the height to the required setting, making sure that the pin holes are aligned.
6. Place the pin in the bottom hole and secure with the Lynch pin. (Fig. 8)

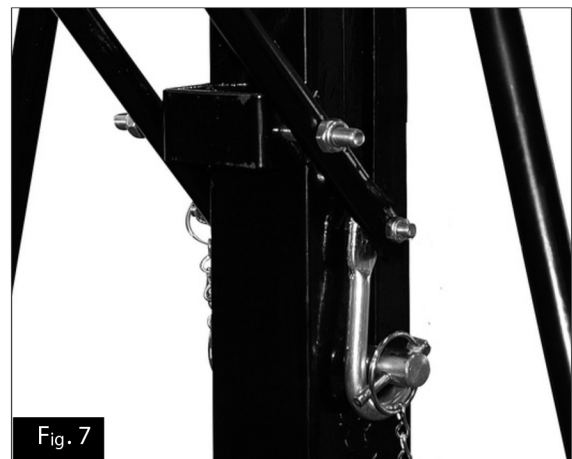

WARNING

Only raise and lower loads when the **CASTOR BRAKES** are **ENGAGED**.
This equipment must not be used outside its limitations, or for any other purpose than that for which it is intended.

PREVENTATIVE MAINTENANCE

General Guidelines

1. Storage:

- Always store the mobile girder rail in a well-protected area to prevent exposure to inclement weather, corrosive vapors, abrasive dust, or other harmful elements.
- Before use, ensure the girder rail is cleaned of water, snow, sand, grit, oil, grease, or other foreign matter.

2. Lubrication:

- Lubricate the wheels and casters with general-purpose grease to ensure smooth operation.

3. Label Maintenance:

- Keep the mobile girder rail capacity rating and any warning or nameplate labels clean and readable. Use a mild soap solution for washing external surfaces.

Frequent Inspections

Conduct daily or monthly visual inspections, focusing on the following items:

Hardware Components:

- Inspect bolts, nuts, washers, safety pins, location pins, lifting hooks, “U” lifting levers, lynch pins, and attaching chains.
- Ensure all components are complete and free from nicks, cracks, broken parts, or bends. Confirm that they are tight and have not come loose.

Caster Wheels:

- Check for cracks and ensure wheels swivel and spin freely. Verify that the locking brake operates correctly.

Periodical Independent Load Testing

While there are no specific legislative requirements for ongoing independent load testing, it is recommended for owners to implement such tests based on their own hazard identification and risk minimization assessments. Consider the following factors:

- Usage Frequency: Assess how often the mobile girder rail is used.
- Maintenance History: Evaluate past maintenance and inspection records.
- Operator Skill: Consider the experience level of the operators.
- Structural Changes: Be aware of any modifications made or reduction to structural integrity which may reduce the overall capacity.

Safety Precautions

Do Not Operate the Mobile Girder Rail if it has loose or missing hardware, components, or if it has been modified in any way. Always take corrective action before using the mobile girder rail again.

SPARE PARTS SECTION

MGT-1T

Mobile Girder Rail Gantry

Order Code C188
10/2024

The following section covers the spare parts diagrams and lists that were current at the time this manual was originally printed. Due to continuous improvements of the machine, changes may be made at any time without notification.

HOW TO ORDER SPARE PARTS

1. Have your machines **model number, serial number & date of manufacture** on hand, these can be found on the specification plate mounted on the machine
2. A scanned copy of your parts list/diagram with required spare part/s identified.

NOTE: SOME PARTS MAY ONLY BE AVAILABLE AS AN ASSEMBLY



WARNING

The machine is the sole responsibility of the owner for its safe use. This responsibility includes but is not limited to proper installation in a safe environment, personnel training, proper inspection and maintenance, manual availability and comprehension. The manufacturer will not be held liable for injury or property damage from negligence, improper training, machine modifications or misuse.

SPARE PARTS DIAGRAM

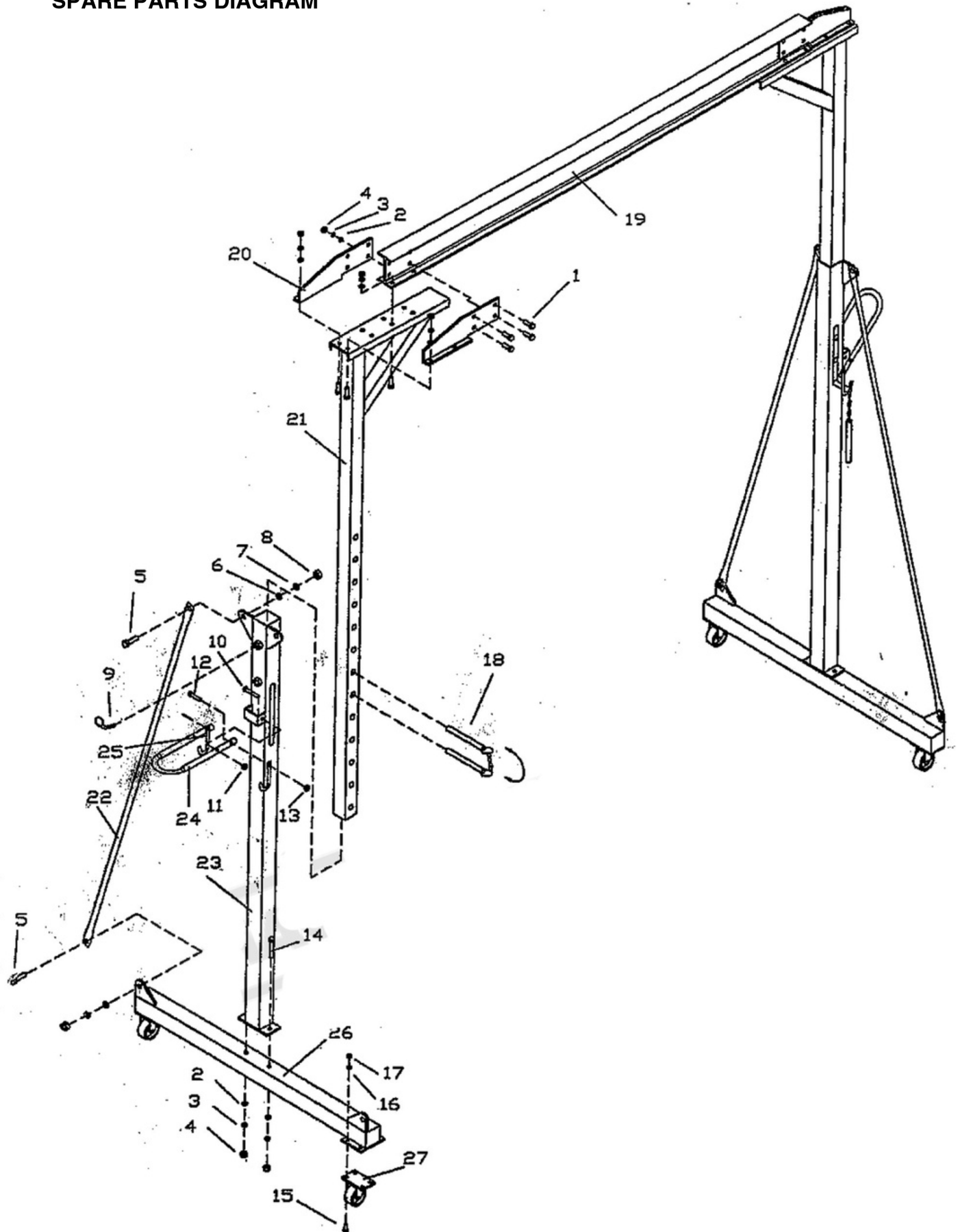

SPARE PARTS LIST

Item	DESCRIPTION	Qty	Item	DESCRIPTION	Qty
1	Bolt M12 x 35	24	14	Bolt M12 x 150	4
2	M12 Flat Washer	28	15	Bolt M10 x 25	16
3	M12 Spring Washer	28	16	M10 Spring Washers	16
4	M12 Nut	28	17	M10 Nut	16
5	Bolt M14 x 40	8	18	Pin	4
6	M14 Flat Washer	8	19	Cross I-Beam	1
7	M14 Spring Washer	8	20	Plate	4
8	M14 Nut	8	21	Inner Vertical Post	2
9	M12 Bolt	4	22	Support Tube	4
10	Bolt M10 x 60	4	23	Outer Vertical Post	2
11	M10 Nut	4	24	Handle	2
12	Bolt M8 x 40	4	25	Pin	4
13	M8 Nut	4	26	Base Assembly	2
			27	Castor Wheels	4

NOTE: SOME INDIVIDUAL PARTS MAY ONLY BE AVAILABLE AS AN ASSEMBLY

WARNING

General Machinery Safety Instructions

Read this entire Manual before using this machine.

- 1. Read the entire Manual before starting machinery.** Machinery may cause serious injury if not correctly used.
 - 2. Always use correct hearing protection when operating machinery.** Machinery noise may cause permanent hearing damage.
 - 3. Machinery must never be used when tired, or under the influence of drugs or alcohol.** When running machinery you must be alert at all times.
 - 4. Wear correct Clothing.** At all times remove all loose clothing, necklaces, rings, jewelry, etc. Long hair must be contained in a hair net. Non-slip protective footwear must be worn.
 - 5. Always wear correct respirators around fumes or dust when operating machinery.** Machinery fumes & dust can cause serious respiratory illness. Dust extractors must be used where applicable.
 - 6. Always wear correct safety glasses.** When machining you must use the correct eye protection to prevent injuring your eyes.
 - 7. Keep work clean and make sure you have good lighting.** Cluttered and dark shadows may cause accidents.
 - 8. Personnel must be properly trained or well supervised when operating machinery.** Make sure you have clear and safe understanding of the machine you are operating.
 - 9. Keep children and visitors away.** Make sure children and visitors are at a safe distance for you work area.
 - 10. Keep your workshop childproof.** Use padlocks, Turnoff master power switches and remove start switch keys.
 - 11. Never leave machine unattended.** Turn power off and wait till machine has come to a complete stop before leaving the machine unattended.
 - 12. Make a safe working environment.** Do not use machine in a damp wet area or where flammable or noxious fumes may exist.
 - 13. Disconnect main power before service machine.** Make sure power switch is in the off position before re-connecting.
 - 14. Use correct amperage extension cords.** Undersized extension cords over heat and lose power. Replace extension cords if they become damaged.
 - 15. Keep machine well maintained.** Keep blades sharp and clean for best and safest performance. Follow instructions when lubricating and changing accessories.
 - 16. Keep machine well guarded.** Make sure guards on machine are in place and are all working correctly.
 - 17. Do not overreach.** Keep proper footing and balance at all times.
 - 18. Secure workpiece.** Use clamps or a vice to hold the work piece where practical. Keeping the work piece secure will free up your hand to operate the machine and will protect hand from injury.
 - 19. Check machine over before operating.** Check machine for damaged parts, loose bolts, Keys and wrenches left on machine and any other conditions that may effect the machines operation. Repair and replace damaged parts.
 - 20. Use recommended accessories.** Refer to instruction manual or ask correct service officer when using accessories. The use of improper accessories may cause the risk of injury.
 - 21. Do not force machinery.** Work at the speed and capacity at which the machine or accessory was designed.
 - 22. Use correct lifting practice.** Always use the correct lifting methods when using machinery. Incorrect lifting methods can cause serious injury.
 - 23. Lock mobile bases.** Make sure any mobile bases are locked before using machine.
 - 24. Allergic reactions.** Certain metal shavings and cutting fluids may cause an allergic reaction in people and animals, especially when cutting as the fumes can be inhaled. Make sure you know what type of metal and cutting fluid you will be exposed to and how to avoid contamination.
 - 25. Call for help.** If at any time you experience difficulties stop the machine and call you nearest branch service department for help.
-
-



WARNING

Mobile Girder Rail Safety Instructions

Read this entire Manual before using this machine.

- 1. Loading Requirements.** Never exceed the I-beam maximum load capacity. Always use the correct certified girder trolley, chain block, lifting slings and chains. Refer to your vehicle service manual to locate the safe engine lifting/support locations, and to verify that the engine weight does not exceed the maximum mobile girder rail load rating. Only connect lifting hooks, chains, or straps at points that can safely support the load and prevent unpredictable load swing or shift.
 - 2. Mobile Girder Rail Condition.** The Mobile Girder Rail must be maintained for a proper working condition. Never operate a Mobile Girder Rail that has damaged or worn parts. Scheduled routine maintenance should be performed on a scheduled basis. Check frame, welds, pins, wheels, slings, chain & hooks for cracks or damage. Replace if necessary.
 - 3. Crushing Hazard.** Never place any part of your body in the lifting mechanism. Serious injury can occur. Never allow anyone to work under a load supported by a Mobile Girder Rail. Never allow the Mobile Girder Rail to be the sole support for the load. Place the load on the ground or use additional correctly rated jack stands to support the load.
 - 4. Work area hazards.** Keep the area around the Mobile Girder Rail clean from oil, tools, objects & chips. Pay attention to other persons in the area and know what is going on around the area to ensure unintended accidents.
 - 5. Warning Labels.** Take note of any warning labels on the Mobile Girder Rail and do not remove them.
 - 6. Safe Surface Use.** Only use the Mobile Girder Rail on hard, level surfaces capable of sustaining the load being lifted. Avoid using the Mobile Girder Rail on inclines or ramps that will cause a loss of control.
 - 7. Safe Operation.** Load must be directly under the Mobile Girder Rail before lifting. Before removing or installing your engine, always apply the wheel brakes of the Mobile Girder trolley. Only move the Mobile Girder Rail with the load as low as possible to the ground to prevent the Mobile Girder Rail tipping due to its high centre of gravity.
 - 8. Do not Modify the Mobile Girder Rail.** Never modify this Mobile Girder Rail or use beam extensions.
 - 9. Other Hazards.** Never allow children to play on this Mobile Girder Rail, and never carry passengers!
 - 10. Storage.** When storing a Mobile Girder Rail make sure it is out of the way of human traffic and always leave it unloaded.
 - 11. Call for help.** If at any time you experience difficulties, stop and call your nearest branch service department for help.
-
-

PLANT SAFETY PROGRAM

NEW MACHINERY HAZARD IDENTIFICATION, ASSESSMENT & CONTROL

Mobile Girder Rail

Developed in Co-operation Between A.W.I.S.A and Australia Chamber of Manufactures
This program is based upon the Safe Work Australia, Code of Practice - Managing Risks of Plant in the Workplace (WHSA 2011 No10)

Item No.	Hazard Identification	Hazard Assessment	Risk Control Strategies <small>(Recommended for Purchase / Buyer / User)</small>
B	CRUSHING	HIGH	<p>Ensure load is correctly slung and approved sling, chains etc are used. Keep body clear from under load. Do not exceed maximum lifting capacity. Wear safety boots. Always check around load before lowering. Check mobile girder rail and lifting equipment for damage etc prior to use. Ensure load is lowered smoothly.</p>
D	SHEARING	MEDIUM	<p>Keep body parts clear between moving components of engine mobile girder rail when lowering.</p>
J	SLIPPING, TRIPPING & FALLING	LOW	<p>Avoid uneven or slippery surfaces when moving mobile girder rail under load. Ensure mobile girder rail is on level solid ground.</p>
<i>Plant Safety Program to be read in conjunction with manufactures instructions</i>			