

### Installation and remark:

1. Before installation, must carefully check whether there are some parts damaged during Transport and stock. For example whether the cable and plug are in good condition, and the insulated resistance is above  $0.5M\Omega$ , otherwise must check the fault.
2. Check whether the power supply is conformed to the stipulation of nameplate before installation. Pump must connect with earth to keep safe.
3. Before installation, must check whether the cable and plug is fractured, scratched, broken, etc. If they are faulty, must consult dealer or technician qualified to replace them.
4. Using iron thread or hoop to make the outlet and discharge pipe tight, and then tie a rope on the handle as sling so as to move the pump up and down.
5. Impacting and pressing the cable is absolutely prohibited. Cable cannot be used for sling. Don't discretionarily drag the cable while the pump is running, to avoid creepage.
6. The power supply connected with the pump must be assembled with Electricity-leaking circuit breaker, and the voltage must be controlled within  $\pm 15\%$  of the rated to avoid destroying the motor.
7. Don't touch and move the pump before cut-off the power to keep safe.
8. Be sure that the connection part between plug and cable is far from the water.
9. Be sure that the plug and cable are far from the heat, oil and the sharp.

### Maintenance

1. Often check cable and duly replace the cable if it is found with fault of fractured, broken etc.
2. After running 2000hrs, please maintenance the pump as per the following steps:  
Disassemble pump: carefully check the spare parts easily worn, for example bearing, mechanical seal, oil seal, "O"ring, impeller etc. And duly replace the spare parts damaged.  
Chang oil: take the charge plug of oil chamber out, and inject 10# oil to 70%-80% of the capacity of chamber(edible earthnut oil is available if no 10# oil).  
Air testing: After maintenance, the pump must be tested by air. Inject high-pressure air into the pump and keep the pressure at 0.2Mpa, it proved to be reliable if no leakage within 5 Minutes.
3. Don't submerge the pump into the water if it isn't started for a long time. Must take the pump out of the water and clean it and then make anti-rust processing.

### Fault and solution (shut off the power before operation )

Fault	Possible cause	Remedy
Pump does not start	<ol style="list-style-type: none"><li>1. Too low voltage;</li><li>2. Impeller blocked;</li><li>3. Stator winding burn up;</li><li>4. Capacitor damaged;</li><li>5. Absent phase (3 phase);</li><li>6. Too large resistance of cable.</li></ol>	<ol style="list-style-type: none"><li>1. Adjust voltage to <math>\pm 15\%</math> of the rated;</li><li>2. Remove obstacles;</li><li>3. Repair;</li><li>4. Replace capacitor;</li><li>5. Check switch and cable connection etc;</li><li>6. Use the proper cable ;</li></ol> <p>(Item 3 and 4 must be operated under the guidance of dealer or technician qualified.)</p>
Pump delivers reduced water	<ol style="list-style-type: none"><li>1. High delivery head;</li><li>2. Filter mesh clogged;</li><li>3. Impeller worn off;</li><li>4. Too shallow submersible depth;</li><li>5. Wrong rotation (3 phase).</li></ol>	<ol style="list-style-type: none"><li>1. Lower the head;</li><li>2. Clean the filter mesh;</li><li>3. Replace impeller;</li><li>4. Adjust the submersible depth above 0.5m;</li><li>5. Inverse two phase.</li></ol>
Pump stops suddenly	<ol style="list-style-type: none"><li>1. Switch cut off or blowout;</li><li>2. Impeller blocked;</li><li>3. Stator winding burn up.</li></ol>	<ol style="list-style-type: none"><li>1. Check power supply, replace fuse;</li><li>2. Shut off power, clean obstacles;</li><li>3. Repair (must consult the dealer and; technician qualified).</li></ol>



Manual 684

Type: 1408

Description: Auto Submersible Pump 2"  
12m Head 240 volt

SPA series submersible drainage pumps

# OPERATION MANUAL

Be sure to keep this manual properly and please carefully read this manual before operation.

SCANNED

ISO9001:2000 CE

1/2



SCANNED  
795

1408



Machine Type: 1408

Auto Submersible Pump Sami, 12m Head  
240 volt.

SPA series submersible drainage pumps

# OPERATION MANUAL

Be sure to keep this manual properly and please  
carefully read this manual before operation.

ISO9001:2000

CE



## Function and feature:

Model SPA standing submersible pump is vastly used for farming, breed aquatics, mine enterprise and construction site. It features its compact size, light weight, and convenient Use. The float switch can automatically control on and off with the change of the liquor level. The protector in the motor can automatically cut off the power when it overheated or overcurrented, thus guarantee the security and reliability of pump's operation even in the atrocious environment.

## Condition of usage:

1. The depth for the electrical pump below the water is no more than 5m;
2. The temperature of the water is no higher of 40°C;
3. The PH figure of the water is between 6.5~8.5;
4. The grain diameter of the solids in the water is no bigger than 0.2mm.

## Technical data:

Model	Power (kw)	Outlet diameter (mm)	Max flow (l/min)	Max head (m)	G.W (kg)	Dimensions (cm)
SPA-250(F)	0.25	40,32,25	130 (7.8m <sup>3</sup> /h)	6.5	7	20.5X18.5X32.5
SPA-370(F)	0.37	50	216 (13m <sup>3</sup> /h)	9	11.5	25.0X22.0X40.5
SPA-400(F)	0.40	50	216 (13m <sup>3</sup> /h)	9	12.5	25.0X22.0X42.5
SPA-550(F)	0.55	50	260 (15.6m <sup>3</sup> /h)	10.5	13.5	24.0X21.5X40.0
SPA-750(F)	0.75	50	330 (19.8m <sup>3</sup> /h)	12	15	27.0X23.5X42.0
SPA-1100(F)	1.1	80	580 (34.8m <sup>3</sup> /h)	9	20.5	45.0X31.5X24.5
SPA3-18-0.55(F)	0.55	40,32,25	108 (6.5m <sup>3</sup> /h)	21	12.5	25.0X22.0X42.5
SPA6-15-0.55(F)	0.55	50,40	250 (15m <sup>3</sup> /h)	17	15	27.0X23.5X42.0
SPA6-18-0.75(F)	0.75	40,32,25	265 (15.9m <sup>3</sup> /h)	21	15	27.0X23.5X42.0
SPA3-24-0.75(F)	0.75	40,32,25	100 (6m <sup>3</sup> /h)	26	15	27.0X23.5X42.0
SPA6-28/2-1.1(F)	1.1	50	208 (12.5m <sup>3</sup> /h)	30	20.5	45.0X31.5X24.5
SPA10-18-1.1(F)	1.1	40	250 (15m <sup>3</sup> /h)	20	22	27.5X22.5X53.0
SPA6-32-1.5(F)	1.5	40	216 (13m <sup>3</sup> /h)	34	26	27.5X22.5X56.0
SPA6-28/2-1.1A(F)	1.1	50	208 (12.5m <sup>3</sup> /h)	30	23	27.5X22.5X53.5
SPA6-39/3-1.5A(F)	1.5	50	208 (12.5m <sup>3</sup> /h)	42	28.5	62.5X28.5X20.5
SPA3-70/3-2.2A(F)	2.2	40	100 (6m <sup>3</sup> /h)	78	36	59.0X35.0X25.0

## Performance curve

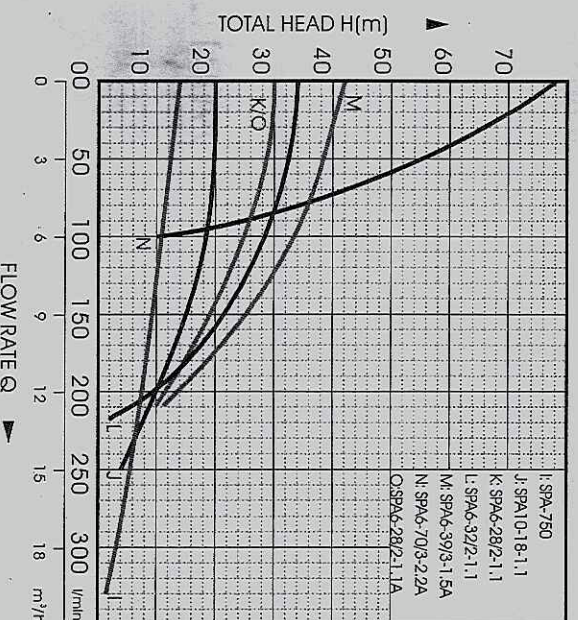
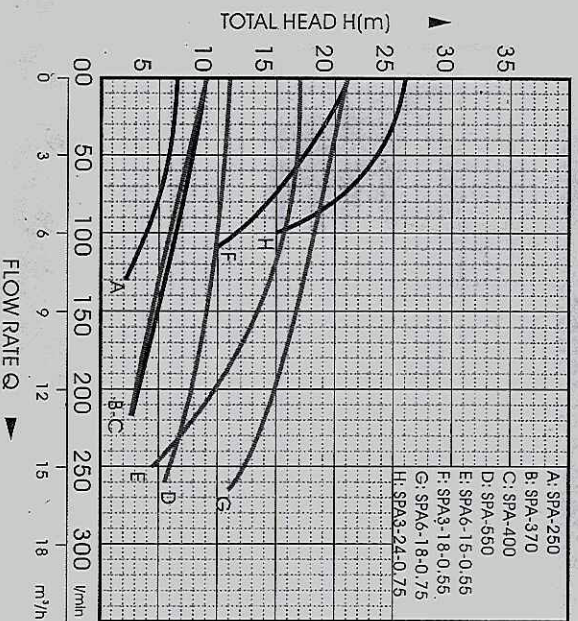

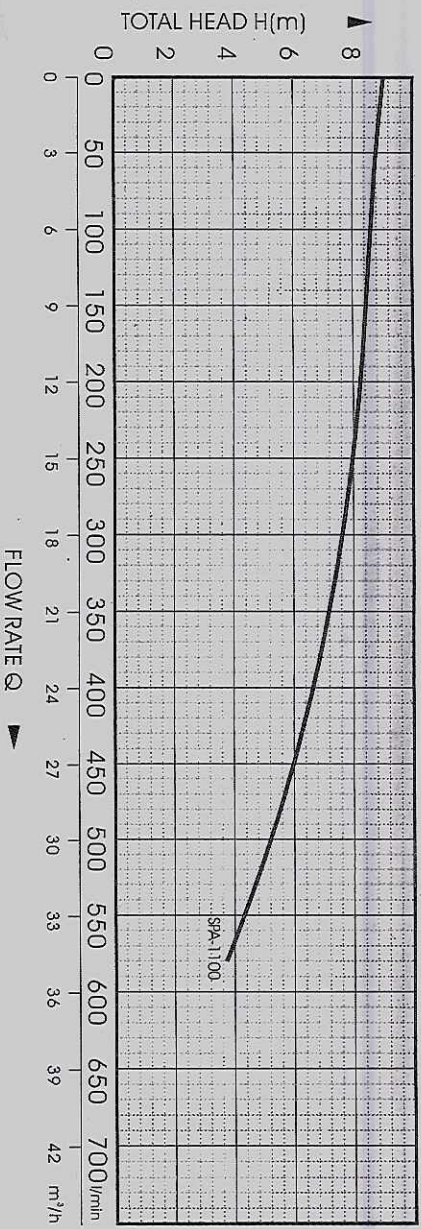

Circuit diagram

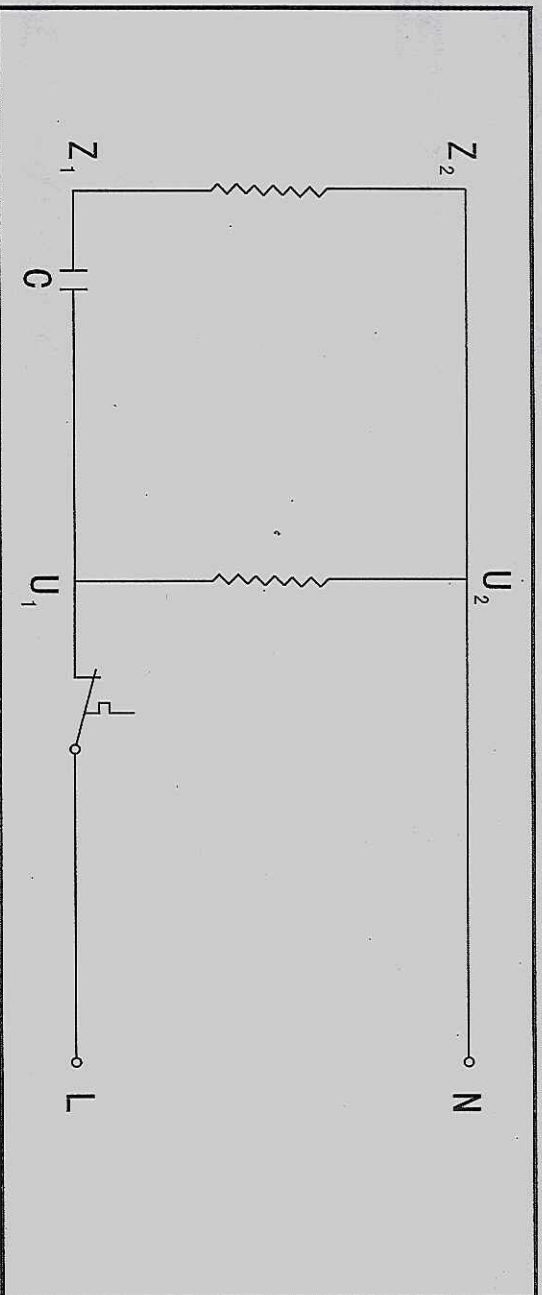

The installation diagrams

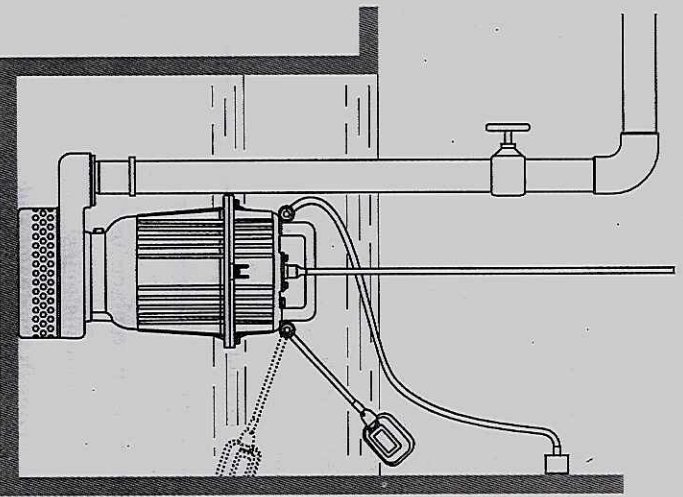

Stationary installation

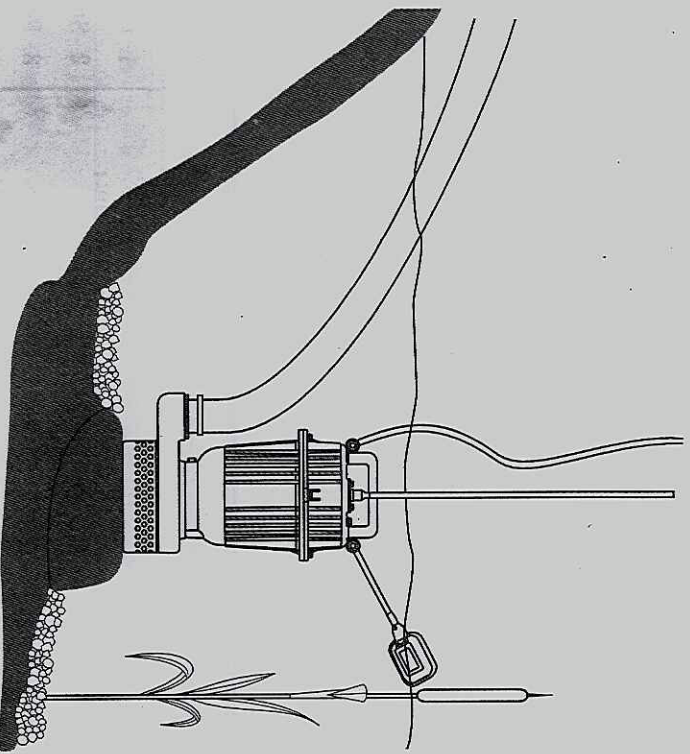

Transportable installation

### Installation and remark:

1. Before installation, must carefully check whether there are some parts damaged during Transport and stock. For example whether the cable and plug are in good condition, and the insulated resistance is above  $0.5M\Omega$ , otherwise must check the fault.
2. Check whether the power supply is conformed to the stipulation of nameplate before installation. Pump must connect with earth to keep safe.
3. Before installation, must check whether the cable and plug is fractured, scratched, broken, etc. If they are faulty, must consult dealer or technician qualified to replace them.
4. Using iron thread or hoop to make the outlet and discharge pipe tight, and then tie a rope on the handle as sling so as to move the pump up and down.
5. Impacting and pressing the cable is absolutely prohibited. Cable cannot be used for sling. Don't discretionarily drag the cable while the pump is running, to avoid creepage.
6. The power supply connected with the pump must be assembled with Electricity-leaking circuit breaker, and the voltage must be controlled within  $\pm 15\%$  of the rated to avoid destroying the motor.
7. Don't touch and move the pump before cut-off the power to keep safe.
8. Be sure that the connection part between plug and cable is far from the water.
9. Be sure that the plug and cable are far from the heat, oil and the sharp.

### Maintenance

1. Often check cable and duly replace the cable if it is found with fault of fractured, broken etc.
2. After running 2000hrs, please maintenance the pump as per the following steps:  
Disassemble pump: carefully check the spare parts easily worn, for example bearing, mechanical seal, oil seal, "O"ring, impeller etc. And duly replace the spare parts damaged.  
Change oil: take the charge plug of oil chamber out, and inject 10# oil to 70%-80% of the capacity of chamber(edible earthnut oil is available if no 10# oil).  
Air testing: After maintenance, the pump must be tested by air. Inject high-pressure air into the pump and keep the pressure at 0.2Mpa, it proved to be reliable if no leakage within 5 Minutes.  
3. Don't submerge the pump into the water if it isn't started for a long time. Must take the pump out of the water and clean it and then make anti-rust processing.

### Fault and solution (shut off the power before operation )

Fault	Possible cause	Remedy
<p><b>Pump does not start</b></p>	<ol style="list-style-type: none"> <li>1. Too low voltage;</li> <li>2. Impeller blocked;</li> <li>3. Stator winding burn up;</li> <li>4. Capacitor damaged;</li> <li>5. Absent phase (3 phase);</li> <li>6. Too large resistance of cable.</li> </ol>	<ol style="list-style-type: none"> <li>1. Adjust voltage to <math>\pm 15\%</math> of the rated;</li> <li>2. Remove obstacles;</li> <li>3. Repair;</li> <li>4. Replace capacitor;</li> <li>5. Check switch and cable connection etc;</li> <li>6. Use the proper cable ;</li> </ol> <p>(Item 3 and 4 must be operated under the guidance of dealer or technician qualified.)</p>
<p><b>Pump delivers reduced water</b></p>	<ol style="list-style-type: none"> <li>1. High delivery head;</li> <li>2. Filter mesh clogged;</li> <li>3. Impeller worn off;</li> <li>4. Too shallow submersible depth;</li> <li>5. Wrong rotation (3 phase).</li> </ol>	<ol style="list-style-type: none"> <li>1. Lower the head;</li> <li>2. Clean the filter mesh;</li> <li>3. Replace impeller;</li> <li>4. Adjust the submersible depth above 0.5m;</li> <li>5. Inverse two phase.</li> </ol>
<p><b>Pump stops suddenly</b></p>	<ol style="list-style-type: none"> <li>1. Switch cut off or blowout;</li> <li>2. Impeller blocked;</li> <li>3. Stator winding burn up.</li> </ol>	<ol style="list-style-type: none"> <li>1. Check power supply, replace fuse;</li> <li>2. Shut off power, clean obstacles;</li> <li>3. Repair (must consult the dealer and; technician qualified).</li> </ol>