

Scanned
11/08



NK KTV KTVE KTZ
KRS GPN NKZ LH
GH

Auto Submersible pump 75mm 3phase

KT2-3-3.7

SN° B-2034697

3.7kW, 7.3amps.

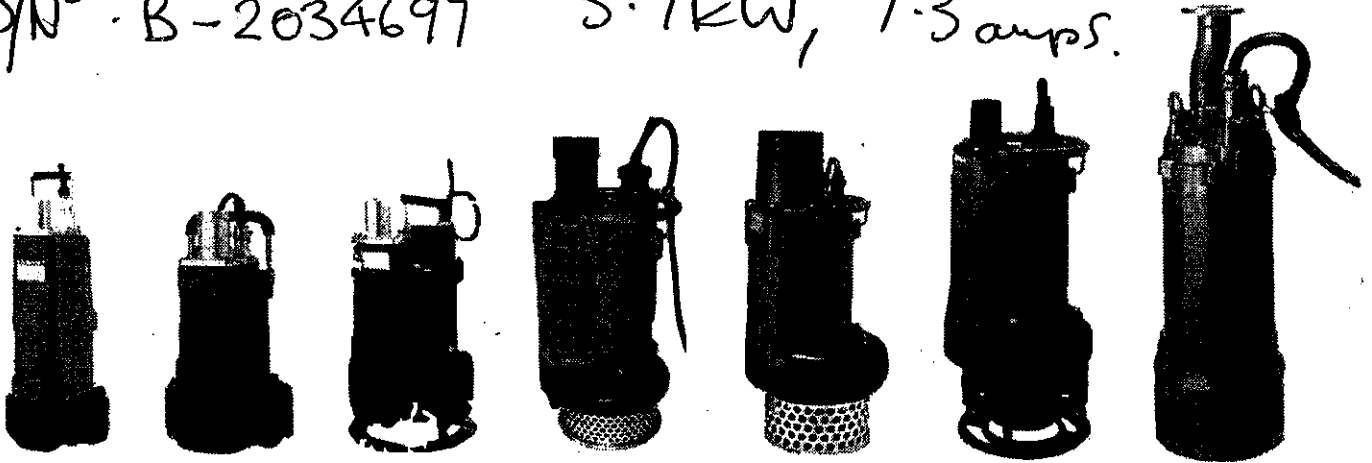

Starting and operating instruction (GB)..... 2/

Auto Submersible pump. 75mm 3phase

plant # 1410 004.

Manual # 449.

Thank you for having selected a Tsurumi submersible pump. For full benefit of this equipment, you should read, before use, the following points which are necessary for safety and reliability anyway. The table of contents guides you to the respective warnings and instructions.

Contents

Applications.....	2	Service and Maintenance.....	4
Product Description.....	2	Trouble Shooting.....	5
Handling and Storage.....	2	Technical Data.....	see appendix
Installation.....	2		
Electrical Connections.....	3		
Operation.....	3		

Applications

These instructions apply to the submersible pumps specified on the cover. They are intended for use with periodic maintenance, under conditions approved by a competent installation technician, in water of up to 40°C, with solids or nonflammable liquids compatible with cast iron, nitrile rubber and the other materials, without the mixture exceeding a viscosity of 10 cp (m pa·s). During use, discharge conduit and cabling should be touched only if need be, and the water absolutely not. The area should be accessible to competent maintenance technicians only, to the absolute exclusion of children and the general public. The pumps conform to the relevant directives of the EU.



CAUTION!
The pump must not be run if it has been partially dismantled

To avoid motor overload, the following content of sand or stony matter in water, and the following density, should not be exceeded (data of other types upon request):

maximum	continuously		intermittently	
	g/litre	density	g/litre	density
KTV, KTZ, NK, KRS, LH, LH-W, GH-311W	10	1,02	20	1,05
KTV2-50	40	1,1	60	1,15
KTV2-80	80	1,2	100	1,25
KRS2-80/100/150	100	1,25	120	1,3









CAUTION!
The pump must not be permanently installed in swimming pools or fountains if the installation area can be flooded.
DANGER!
The pump must not be used in an explosive or flammable environment or for pumping flammable liquids.

Product Description

See table for technical data; see definitions of the icons used, below. Individual performance graphs, dimension diagrams and any other data wanted for proper selection and installation will be gladly provided upon request by the local Tsurumi agent.

The significance of the text in the table (appendix) is as follows:

- | | |
|--|---|
|  =Speed of rotation |  =Electric cable |
|  =Oil volume |  =Mechanical seal |
|  =Immersion depth (maximum) |  =Dry weight (without cable) |

 =Dimensions

P_2 =Rated power

I_0 =Rated current

P_1 =Power input

I_{max} =Starting current

Q_{max} =max. flow rate

H_{max} =max. head

 =connection to terminal board (diagram in appendix)

The pumps should not be used in an atmosphere that could become explosive nor in water that might contain traces of flammable liquid.

Handling and Storage

The pump can be transported and stored either vertically or horizontally. Make sure that it is securely lashed and cannot roll.



CAUTION!
Always lift the pump by the lifting handle - never by the motor cable or hose.
The time between delivery and the first hour of pumping is extremely hazardous. Care need be taken not to crush, kink or pull the fragile cable and not to break the hard but brittle cast iron or endanger a bystander. No water should enter the open end of the cable during handling.



CAUTION!
The pump must always rest on a firm surface so that it will not overturn. This applies to all handling, transport, testing and installation.

Store in a dry place to avoid corrosion by damp air inside the pump. The pump should first be rinsed if a corrosive mixture has been pumped. Rinsing with water mixed with cutting oil can be of some help if no dry storage is available.

Installation



CAUTION!
The lifting tackle must always be designed to suit the pump weight. See under the heading "Product description".

Safety measures

In order to reduce the risk of accidents during service and installation work, take extreme care and bear in mind the risk of electrical accidents.

Only a competent electrician should be allowed to work on the electrical circuit, since only he knows the dangers involved and the regulations.

Do not connect the power supply if any part of the pump or its installation has not been completed and inspected, or if anyone is touching the water.

Installation:

If the pressure at the pump outlet is very low, say less than 1 bar, 1kg/cm² or 10 m H₂O (water column), layflat hose is used nearly exclusively. Folds in the hose can reduce or stop the flow from the pump. Using spiral reinforced hose at least for the first 5m or so and to go over a possible wall or edge, is an improvement, even for higher pressures. Better to use layflat hose only in straight lengths.

If the pressure at the pump outlet is high and/or hose diameter large, loosening or rupture of a hose can result in violent movement or flooding. With large hoses (8" to 12"), the weight of water, stiffening when (even under slight) pressure and axial force of the water combine to make for unreliability unless expert attention is given to selection and erection. Rigid lightweight quick-couple piping and bends, available on the market up to 12", lessen the risk.

Lifting:

Every pump needs a stout lifting rope. Its end must remain accessible under all circumstances.

Cable:

The cable and its possible watertight connection and extension cable must reach to a level beyond reach of flooding. An electrician can extend a cable and make the splice waterproof, if he is experienced and has the proper 3M or equivalent kit. Replacement of the cable, in a workshop only, is always preferable.

Voltage loss due to underrated cabling between power source and pump, is by far the most common cause of motor overload.

Only a competent electrician should be allowed to work on the electrical circuit, since only he knows the dangers involved and the regulations to be followed.

Before switching on:

Do not connect the power supply if any part of the pump or its installation has not been completed and inspected, or if anyone is touching the water.

Two additional hazards for the cable are snagging whilst the pump is being lowered, and crushing by vehicle tires or tracks. Transport is also a potential source of change.

Electrical Connections

The pump must be connected to terminals or starting equipment installed at a level at which it cannot be flooded.

All electrical work must be carried out by an authorized electrician.

Only open a motor at a workshop. All measurements must be made at the free end of the cable.

NOTE!

If a plug and socket are used, the grounding lead should be longer than the phases to ensure that the other leads will, in case of a strong pull, be torn first.



CAUTION!

All electrical equipment must always be earthed (grounded). This applies both to the pump and to any monitoring equipment.

Improper wiring can lead to current leakage, electrical shock or fire.

Be sure to use a ground leakage breaker and an overcurrent protector (or breaker) to prevent damage to the pump that may lead to electrical shock. Imperfect grounding can cause the pump to be put out of operation by electro-galvanic corrosion very quickly.



CAUTION!

Before connecting the cable to the terminal board, make sure that the power supply (i.e. circuit breaker) is properly disconnected. Failure to do so may lead to electrical shock, short, or injury caused by the unintended starting of the pump.



CAUTION!

If a cable is damaged, it must always be replaced.



CAUTION!

The electrical installations must conform to national and local regulations.

For connecting the cables correctly to the terminal board please keep to the diagram indicated in the table in the appendix

Check that the mains voltage, frequency, starting equipment and method agree with the particulars stamped on the motor rating plate.

Rated Frequency must be within $\pm 1\text{Hz}$, and rated voltage within $\pm 5\%$, of the power supply actual values. Check that the thermal overload relays are set to the pump's rated ampere draw and that they are correctly connected.

Connection of stator and motor conductors

If the pump is not fitted with a connector, please contact your Tsurumi dealer.

To enable the correct connections to be made, the number of conductors, any monitoring equipment and the method of starting (see name plate) must be known.

Cable cable

If one or more extension cables are used, they may need to be of larger section than the pump cable, according to length and possible other loads. A cable of insufficient section results in loss of voltage and hence overheating of motor and cable, which may lead to repeated motor stoppage, unreliability, shortcircuit, fire, current leakage and electric shock. So does a damaged or unsecurely wired cable, the more so if it is submerged. No attempt should be made to replace or splice the pump cable, or open the motor, outside of a suitably manned workshop. Always protect the cable against pulling, crushing, grazing and kinking, as the copper conductors are fragile and must remain insulated to avoid lack of voltage, shortcircuiting or electric shock. Apply no load to a cable that is lying in a roll, as a peak voltage can result, high enough to burn through the insulation.

Operation

Before Starting:

Check that all persons concerned agree that all verifications have been completed. Check that all bolts are tight and the pump's weight is supported, the discharge conduit has been connected up, nobody is touching the water nor is unnecessarily near the conduit or switchgear. Be prepared to stop at once.



CAUTION!

The starting jerk may be violent. Don't hold the pump handle when checking the direction of rotation.

Make sure that the pump is firmly supported and cannot rotate.

The pump will jerk anti-clockwise when viewed from above, indicating that it is running clockwise. If not, two of the three phases U, V, W should be transposed with care by an electrician at the point of connection of pump cable to starter.

In the case of star delta please ask your Tsurumi dealer.

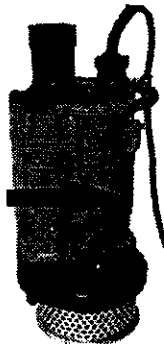

CAUTION!

Reversal of the direction of rotation on a plug that has no phase transposing device may be done only by an authorized person.



CAUTION!

If the built-in motor protection has tripped, the pump will stop but will restart automatically when it has cooled down. NEVER open the motor to make measurements, this can be done at the free end of the cable.



WARNING!

Never insert your hand or any other object into the inlet opening on the underside of the pump casing when the pump is connected to the power supply.

Before inspecting the pump casing, check that the pump has been isolated from the power supply and cannot be energized.

**CAUTION!**

In the event of inward leakage, the oil housing may be pressurized. When removing the oil plug, hold a piece of cloth over it to prevent oil from splashing.

NOTE!

Old oil should be entrusted to an oil disposal company in accordance with local regulations.
The gasket and the O-ring for the oil filler plug must be replaced with a new part at each oil inspection and change.

Bearing Grease (only LH with more than 55kW):

Remove grease plug (55-75kW (PT 1/8)), (90-110kW (M12 screw)) and pour in grease according to the table and drawing below.

LH pumps with 90-110kW have an upper and lower bearing. Upper grease plug PT1/4, lower grease plug as above.

Note: Replenishment period is 3000 hours. However it may vary according to operating conditions.

Model	kind of grease	Initial quantity	Replenishment
LH855 LH675 LH875	e.g. Multitemp LRL3 (Kyodo)	100g	50g
LH690 LH890 LH8110 LH8110	e.g. Multi Knock Delux Grease (Nisseki)	100g	30g
		200g	60g

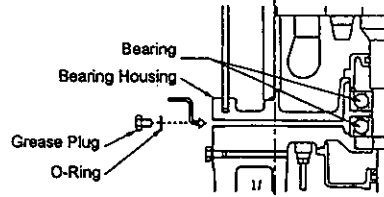
**Replacing the impeller****CAUTION!**

Before disassembling and reassembling the pump, be sure that the power supply is disconnected, and remove the cabtyre cable from the terminal board. To prevent serious accidents, do not perform a conduction test during disassembly and reassembly.

**CAUTION!**

A worn impeller often has sharp edges. Take care not to cut yourself on them.

**WARNING!**

Never insert your hand or any other object into the inlet opening on the underside of the pump casing when the pump is connected to the power supply.

Before inspecting the pump casing, check that the pump has been isolated from the power supply and cannot be energized.

Make sure that the pump is completely reassembled before putting into operation again. Take care that bystanders keep a safe distance and avoid contact with the water.

**CAUTION!**

Be sure to perform a trial operation when starting the pump after a reassembly. If the pump was assembled improperly, it may lead to abnormal operation, electrical shock, or water damage.

Removal of the suction cover (wear plate) and especially removal of the impeller, and even more so the shaft sealing, must be left to a mechanic. Show him the sectional view.

If the pump has a strange smell or appearance, have it cleaned professionally before the mechanic touches it.

When reassembling, the mechanic will turn the impeller by hand to check that it turns freely and that there is no ticking or grating noise from a bearing. Impellers that are not of the vortex type, have a clearance with respect to the suction cover (wear plate) of about 0,3 to 0,5 mm when new or repaired.

Trouble shooting

**CAUTION!**

To prevent serious accidents, disconnect the power supply before inspecting the pump.

Read this Operation Manual carefully before requesting repair. After re-inspecting the pump, if it does not operate normally, contact your Tsurumi-dealer.

Pump fails to start	<p>Pump is new or has been repaired and tested</p> <ul style="list-style-type: none"> • Check that voltage applied agree with rating plate. • Check at pump cable free end (never open motor) insulation value of earth lead (over 20M Ohm), and continuity of winding. On three phase motor check whether ohm values of three windings are within $\pm 10\%$. <p>Pump has been satisfactorily in use</p> <ul style="list-style-type: none"> • Same as above except that also impeller needs to be checked (stone, debris, rust between impeller blades and suction cover after long disuse).
Pump starts but stops immediately, causing the motor protector to actuate	<ul style="list-style-type: none"> • Motor windings or cable damaged. Do not open motor. Check as above. • Impeller blocked or choked. • If pump is new, wrong voltage or frequency. • Voltage too low (most common cause); check supply voltage under load. • If voltage is from diesel generator, inexact frequency. • Wrong direction of rotation. • Liquid of too high viscosity or density. • Wrong setting of thermal overload unit.
The pump's head and pumping volume is lower	<ul style="list-style-type: none"> • Wrong direction of rotation. • Piping resistance too high. • Impeller worn, partially choked or severely narrowed by hard deposits. • Strainer or inlet blocked. • Pump draws air, or liquid is partly volatile or contains high level of gas in solution.
The pump generates noise or vibration	<ul style="list-style-type: none"> • Wrong direction or rotation. • Solid object (stone, etc.) in volute. • Impeller severely damaged, or bearing damaged. Repair at once. • Pump lying on its side and drawing a little air. High wear rate likely.

Description of parts:
(see exploded view in appendix)

No.	Part Name	No.	Part Name	No.	Part Name
1	Hexagonal bolt	12	Hexagonal bolt	23	Impeller nut
2	Spring washer	13	Shaft sleeve	24	Suction cover packing (gasket)
3	Mechanical seal	14	Pump casing	25	Suction cover
4	Oil ring	15	Spring washer	26	Spring washer
5	Rounded head screw	16	Hexagonal bolt	27	Hexagonal bolt
6	O-ring	17	O-ring	28	Spring washer
7	Packing (Gasket)	18	Labyrinth ring	29	Stud bolt
8	Oil casing	19	Impeller adjusting washer	30	Strainer
9	Packing (Gasket)	20	Impeller	31	Bottom plate
10	Oil plug	21	Impeller thread protective cover	32	Spring washer
11	Spring washer	22	Hexagonal nut	33	Hexagonal bolt

Service and Maintenance



CAUTION!

Before any work is started, check that the pump is isolated from the power supply and cannot be energized.

Note:

In the appendix is the sectional drawing of a model of the KTZ-series that is representative for the majority of our pumps. Due to the large number of different models we have to ask you to contact your Tsurumi dealer if you need a parts list or a drawing of a certain model.

If the pump will not be operated for a long period of time, pull the pump up, allow it to dry, and store it indoors. If the pump remains immersed in water, operate the pump on a regular basis (i.e. once a week) to prevent the impeller from seizing due to rust.

In one application, a pump can be under constant risk, and even with frequent attention may have a short life. In another application a pump can run for years without any maintenance at all. Recommendations as to intervals, need interpretation, with the most hazardous characteristic in mind. At least superficial periodic inspection is needed in order to maintain a certain level of reliability and safety.

Remove any debris attached to the pump's outer surface, and wash the pump with tap water. Pay particular attention to the impeller area, and completely remove any debris from the impeller.

Verify that the paint is not peeled, that there is no damage, and that the bolts and nuts have not loosened. If the paint has peeled, allow the pump to dry and apply touch-up paint.



WARNING!

Never insert your hand or any other object into the inlet opening on the underside of the pump casing when the pump is connected to the power supply.

Before inspecting the pump casing, check that the pump has been isolated from the power supply and cannot be energized. Make sure that the pump is completely reassembled before putting into operation again. Take care that bystanders keep a safe distance to the conduit or switch gear and avoid contact with the water.

Interval	Inspection Item	
Monthly	1. Measuring insulation resistance 2. Measuring the loaded current 3. Measuring the power supply voltage 4. Inspecting the impeller	Insulation resistance reference value = 20M Ohm NOTE: The motor must be inspected if the insulation resistance is considerably lower than that obtained during the last inspection To be within the rated current Power supply voltage tolerance=±5% of rated voltage If the performance level has decreased considerably, the impeller may be worn.
Once every 2 to 5 years	Overhaul	The pump must be overhauled even if the pump appears normal during operation. The pump may need to be overhauled earlier if it is used continuously or repeatedly. NOTE: Contact your Tsurumi-dealer to overhaul the pump.
Periodical inspection and replacement of lubricant	KTV2-50, KRS2-50/80/100: Inspection: Every 2000 hours of running time or every 6 months, whichever comes first Changing interval: Every 4000 hours of running time or every 12 months, whichever comes first. Other models: Inspection: Every 3000 hours of running time or every 6 months, whichever comes first. Changing Interval: Every 4000 hours of running time or every 12 months, whichever comes first	

Choking:

Access of the water to the pump and apparent discharge capacity obviously need to be checked as often as experience dictates. Suspending the pump at the ideal level, if need be from a raft, is the main thing. Basically, the strainer should be free and if the pump is meant to remove water it should not carry more sand and pebbles than necessary.

The inlet should be protected from solids, if occurring in sufficient quantity to block the holes of the strainer, preventing flow. A cage, pierced drum or mesh can help. Flow can in rare cases also be stopped by quantities of small stringy vegetal matter wrapping itself around the impeller blades.

Sand wears out the suction cover (wear plate) and shaft seal of any pump. This wear is roughly proportional to the square of the pressure, so it can be worth while using an extra large diameter delivery hose or pipe; very rarely will this lead to settling of sand or pebbles unless high concentration, an obstructed strainer, worn impeller, increased head or a constricted delivery conduit have resulted in diminished flow. If the pump is to remove water, often it can be placed on a raised object or suspended from masonry, piles or an improvised raft. If a pump buries itself in earth, or is buried by a landslide, it can be ruined in minutes.

Generating Set:

Hz to be within ±1 Hz, and voltage within ±5%, may also need to be checked frequently, if power is provided by a generating set. The lighter the generating set, the higher the risk of erratic voltage and wrong frequency.

Insulation Check:

Less obvious than oil inspection but equally valuable, is a periodic check of insulation value between the pump cable's earth lead and the other leads, and between the other leads, by means of an insulation tester. This value, well over 20 M Ohm when the pump is new or reconditioned, should be at least 10 M Ohm when the pump and its cable have been in the water for a long time. If it is down to 10M Ohm, repair in a workshop is urgently needed. It is useful to keep a record of measurements of this insulation value, and of ampere draw if possible, over the years, so as to notice a steep decline of the ohm value before a short occurs in the motor winding. Decreased ampere draw indicates impeller wear.

On workshop inspection, if it is found that the cable is at fault, it should not be re-used, even if 30 M Ohm insulation can be restored. If the motor is at fault, the winding specialist can opt for oven drying and revarnishing under vacuum, or in a favourable case drying only. In the latter case, dry at no more than 60°C with motor protector still fitted or at not more than 105°C with motor protector removed. In case of oven drying, insulation should be higher than 5 M Ohm when hot or 20 M Ohm when cooled down.

Oil:

Replace the oil also if it is slightly greyish or contains a droplet of water. Ensure that electric power cannot be accidentally applied to the pump. Lay the pump on its side, remove the plug, holding a piece of cloth over it to prevent possible spraying. If the oil is greyish or contains water drops or dust, or if there is less than 80% of the recommended quantity left, then measure carefully at the cable's end (never open the motor outside a workshop) the ohm resistance between the leads and replace shaft seal to avoid humidity getting into the motor and shorting the windings. Use turbine oil (ISO VG32).

Use the quantity specified in the specification table. Dispose of old oil in accordance with local regulations. Carefully check the packing (gasket) of the filling plug and replace.



Submersible General Dewatering Pump

KTZ Series

OPERATION & SERVICE MANUAL

Manual # 449

Part # 1410 004

Auto Sub. Pump 75mm
3phase

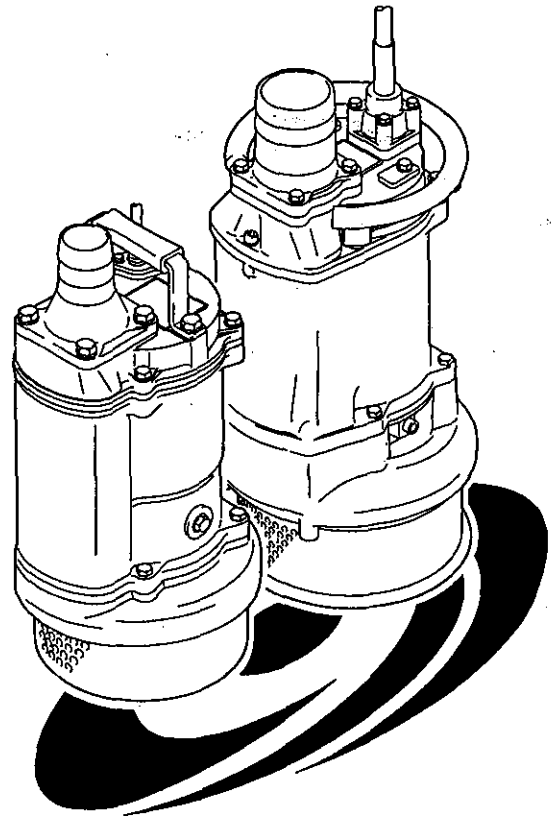

TSURUMI MANUFACTURING CO., LTD.

WARRANTY

Tsurumi undertakes to remedy faults in products sold by Tsurumi provided :

- that the fault is due to defects in design , materials or workmanship :
- that the fault is reported to Tsurumi or Tsurumi's representative during the guarantee period (which is one year from the date of shipment from JAPAN)
- that the product is used only under conditions described in the instruction Manual and in applications for which it is intended :
- that all modification or repair work is done by Tsurumi :
- that genuine Tsurumi parts are used .

Hence , the guarantee dose not cover faults caused by deficient maintenance , improper installation , incorrectly executed repair work or normal wear and tear .

Tsurumi assumes no liability for either bodily injuries , material damages or economic losses beyond what is stated above .

Disposal of Product

Properly dispose of the product by disassembling it, presorting the contents, and sending them to the waste material treatment site.

INTRODUCTION

Thank you for selecting the KTZ Series Tsurumi Submersible General Dewatering Pump.

This manual explains how to use this equipment and gives instructions on precautions to take during use. In order to understand the features of the KTZ Series and to use it in the most effective manner, read this manual before using the pump.

This equipment should not be used for applications other than those listed in this manual. In the event of a malfunction or an accident, the manufacturer will not assume any liability. We recommend that after you read this manual, you keep it on hand so that you may be able to refer to it later.

In case you lend this equipment to someone, be sure to also lend this manual together with the equipment.

In case this manual is lost or damaged, contact with the dealer from whom you purchased the equipment, or the Tsurumi sales office in your area.

This manual was prepared with the utmost attention to details. However, if you find any errors or omissions, contact with the dealer from whom you purchased the equipment, or the Tsurumi sales office in your area.

The content of this manual may not be copied, in whole or part, without consent of Tsurumi Manufacturing Co., Ltd.

Contents

1	PUMP PART NAMES	1
2	PRIOR TO USE	2
	Inspecting the Product	2
	Inspecting the Specification	2
	Product Specifications	2
3	INSTALLATION	3
	Preparation for Installation	3
	Pre-Installation Check	4
	Precautions During Installation	4
4	ELECTRICAL WIRING	6
	Electrical Wiring Work	6
	Grounding	6
	Cable/Re Cable	6
	Connecting the Cable/Re Cable	7
	Wiring Diagram	7
5	Operation	8
	Before Operation	8
	Trial Operation	8
	Operation	10
	Circle Thermal Protector	10
	Water Level During Operation	11
6	MAINTENANCE AND INSPECTION	12
	Periodical Inspection	12
	Storage	13
	Oil Inspection and Changing Procedures	13
	Maintenance	14
7	DISASSEMBLY AND REASSEMBLY PROCEDURE	14
	Disassembly Procedure for KTZ21.5	14
	Reassembly Procedure	15
	KTZ 21.5	16
	Disassembly Procedure for KTZ47.5	17
	Reassembly Procedure	17
	KTZ 47.5	18
8	TROUBLESHOOTING	19

1 PUMP PART NAMES

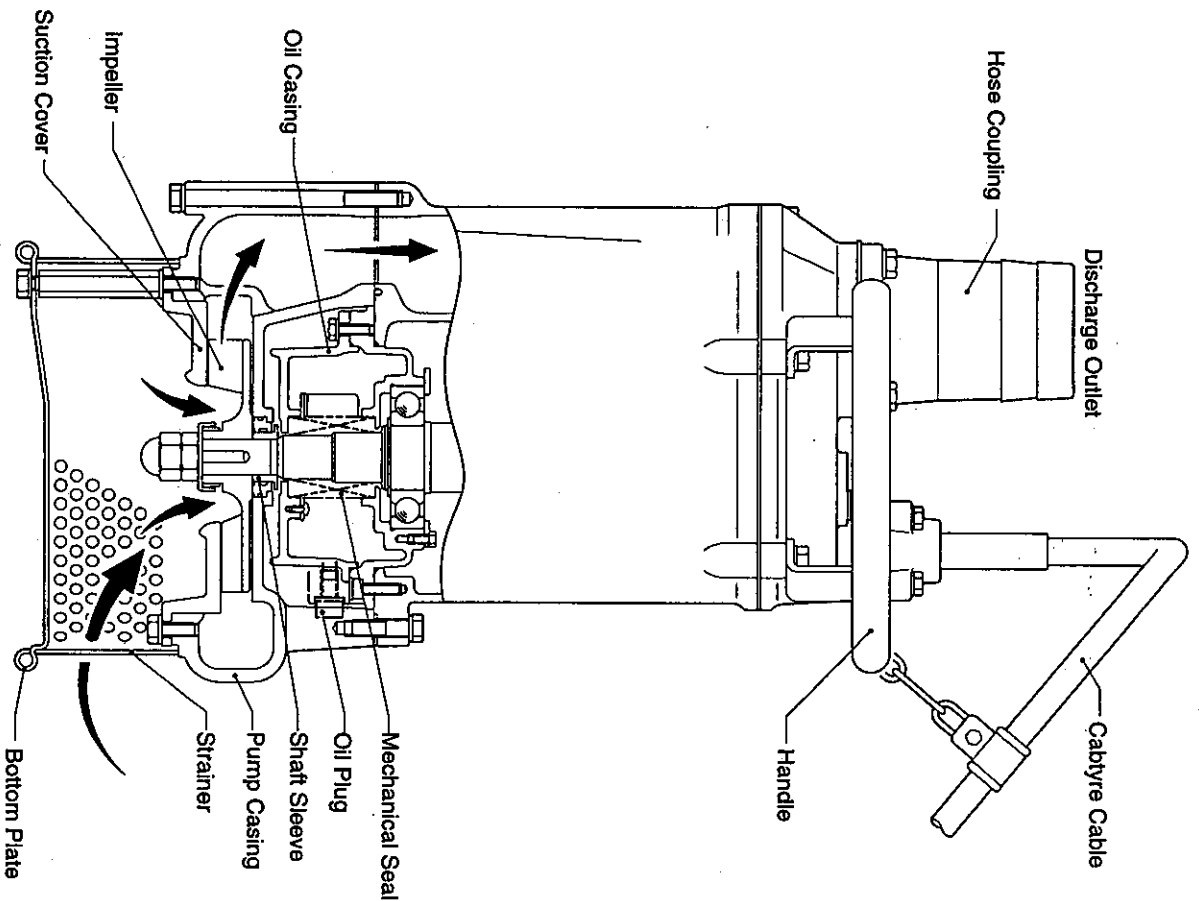

NOTE: This diagram shows the part layout of a typical KTZ model. The external appearance and the internal construction may vary slightly, depending on your particular model.

2 PRIOR TO USE

Check the following points after receiving the pump:

Inspecting the Product

Unpack the package and verify that no damage has occurred during shipment and that the bolts and nuts have not loosened.

Inspecting the Specification

Check the nameplate of the pump unit to verify that it is the product that you have ordered. Pay particular attention to its voltage and frequency specifications.

NOTE: If you discover any damage or discrepancy, please contact with the Tsurumi dealer from whom you purchased the product or the nearest Tsurumi representative office.

Product Specifications

CAUTION! Do not use the product under conditions other than those specified. Doing so may lead to short, electrical shock, or fire, or might inhibit the product from attaining its full potential.

Main Components Specifications

F L U I D	TYPE/TEMPERATURE	Work drainage and sand carrying/0 to 40°C
P U M P	IMPELLER	Open
	SHAFT SEAL	Double mechanical seal
M O T O R	BEARING	Sealed ball bearing
	TYPE POLES	Dry type submersible induction motor, 2 poles
	INSULATION	Class F
DISCHARGE CONNECTION	MOTOR PROTECTOR (BUILT-IN)	Circle thermal protector
	LUBRICANT	Turbine oil VG32
DISCHARGE CONNECTION		Hose coupling

Specifications 50/60Hz

DISCHARGE BORE mm	MODEL	MOTOR OUTPUT kW	MAX HEAD		MAX CAPACITY		STARTING METHOD	DRY WEIGHT kg
			m	feet	m ³ /min	GPM		
50	KTZ215	1.5	21.5/23.0	71/75	0.43/0.40	114/105	Direct-on-the	30
50	KTZ222	2.2	26.0/30.5	85/100	0.50	132	Direct-on-the	34
50	KTZ237	3.7	36.5/35.0	120/115	0.45/0.54	119/143	Direct-on-the	62.5
80	KTZ315	1.5	14.4	47	0.67/0.88	177/180	Direct-on-the	30
80	KTZ322	2.2	20.4	67	0.80/0.77	211/203	Direct-on-the	34
80	KTZ337	3.7	29.0/31.0	95/101	0.90/0.83	239/219	Direct-on-the	62.5
80	KTZ355	5.5	32.0/38.0	105/124	1.10/0.99	291/260	Direct-on-the	82
100	KTZ437	3.7	18.0/18.5	59/61	1.44/1.46	380/396	Direct-on-the	62.5
100	KTZ455	5.5	22.4/24.0	73/78	1.75/1.61	462/428	Direct-on-the	82
100	KTZ475	7.5	40.0/42.0	131/137	1.40/1.32	370/349	Direct-on-the	105
100	KTZ411	11	48.5/51.0	159/167	1.44/1.43	380/377	Direct-on-the	133
150	KTZ675	7.5	31.0	102	2.04/2.08	539/549	Direct-on-the	107
150	KTZ611	11	32.5	107	2.44	645	Direct-on-the	136

NOTE: • Dry weight of the pump excluding cable.

3 INSTALLATION

CAUTION!

- The supply voltage should be within $\pm 5\%$ of the rated voltage.
- To use the pump, the water temperature should be between 0°C and 40°C.
- The pump should be used only for pumping plain water. The pump should not be used to pump fluids such as oil, sea water, or organic solvents.
- The pump must never be used to pump explosive liquids and should never be operated in an area from whom explosive elements might be present.
- The pump must not be used in a partially disassembled state.

NOTE: When using the pump for a special solution, please consult the dealer from whom you purchased the equipment, or the Tsurumi sales office in your area.

Critical Pressure

CAUTION!

Do not use the pump in an area where the water pressure exceeds the values given below, as it may damage the pump, or cause a short or electrical shock.

M O D E L	Critical Pressure
KTZ 215	KTZ 315
KTZ 222	KTZ 322
KTZ 237	KTZ 337
KTZ 437	KTZ 355
KTZ 455	
KTZ 475	KTZ 675
KTZ 411	KTZ 611
	0.5MPa (5kgf/cm ²) - Discharge pressure during use
	0.5MPa (5kgf/cm ²) - Discharge pressure during use
	0.5MPa (5kgf/cm ²)

Preparation for Installation

Listed below are tools and instruments that are needed to install the submersible pump for general dewatering purpose.

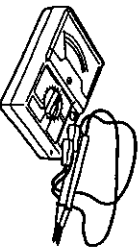

AC voltmeter (tester)

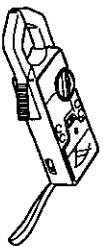

AC ammeter (clamp)

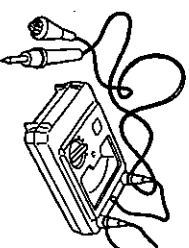

Insulation resistance tester (megger tester)

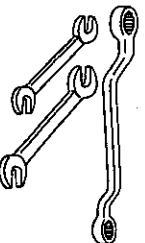

Wrenches for fastening bolts and nuts

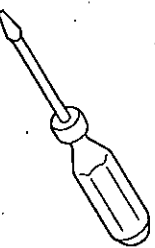

Wrenches for connecting the power supply (a screwdriver or a box wrench)

NOTE: Consult the operation manual provided with each tester for the proper use of the tester.

Pre-Installation Check

Using a megger tester, measure the resistance between each of the core wires and the ground wire (green) to verify the insulation resistance of the motor.

■ Insulation resistance reference value = 20MΩ min.

NOTE: The insulation reference value of 20MΩ min. is based on a new or repaired pump. For reference values of a pump that has already been installed, refer to "6. Maintenance and Inspection" on page 12 of this manual.

Precautions During Installation

- (1) Push the hose all the way to the base of the hose coupling. Tighten the hose clamp to secure the hose in place.

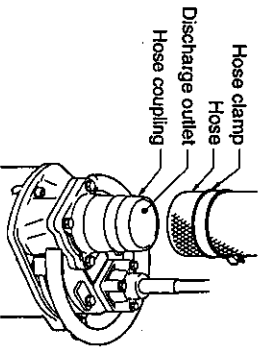

NOTE: A hose coupling designed for use with a suction hose is available separately. The hose coupling should be used when using a hose as a suction hose. However, the existing coupling may be used on the 11kW models.

⚠ WARNING!!

When installing the pump, be mindful of the pump's center of gravity and weight. If the pump is not suspended properly, the pump may fall and break, which may lead to injury.

⚠ CAUTION!

- When installing or moving the pump, do not suspend the pump by the cable. Doing so will damage the cable, which may cause a short, electrical shock, or fire.
- When transporting the pump manually, be sure to have a sufficient number of people to carry out the task. To prevent back injury when lifting, bend your knees without bending your back.

- (2) Handle the pump carefully. Do not drop it or expose it to strong impacts. When suspending the pump to raise or to lower it, attach a wire rope or a chain to the pump's handle.

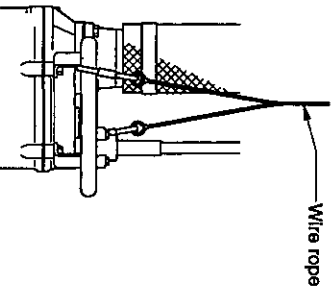

NOTE: For proper procedures for handling the cable, refer to "4. Electrical Wiring" on page 6 of this manual.

⚠ CAUTION!

• Do not operate the pump dry. Doing so will prevent the pump from attaining its full potential and may also damage the pump and lead to a short and electrical shock.

• In order to properly discharge water, provide adequate piping to the area where the pump is mounted. Improper piping may lead to water leakage or other malfunctions.

- (3) Install the pump only in an area that can maintain a proper water level.

NOTE: For details on the water level necessary for pump operation, refer to the section on "Water Level During Operation" on page 11 of this manual.

- (4) When using a hose to provide piping to the pump, observe the following:

Use the shortest possible length of discharge hose and minimize the number of bends. Verify that the end of the hose (discharge side) is lifted above the water surface. If the end of the hose is submerged in water, it may cause the water to flow back when the pump has been stopped. If the end of the hose is located at a level that is lower than that of the source water surface, water may continue to flow out even after the pump has been stopped.

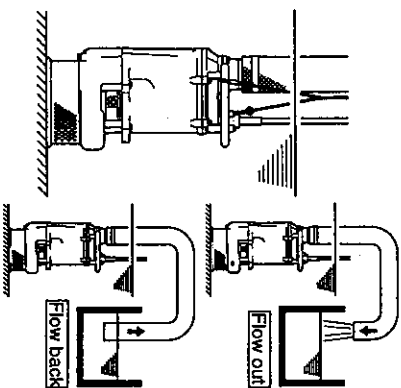

NOTE: Appropriate piping materials must be provided by the user. Piping materials are not included with the product.

⚠ CAUTION!

If an excessive amount of sediment is drawn into the pump, it may cause the pump to wear, which can lead to current leakage or electrical shock.

- (5) The pump must be placed upright during operation. If there is a risk that the pump could be buried under the sediment, place the pump on a base made up of materials such as concrete blocks.

4 ELECTRICAL WIRING

Electrical Wiring Work

⚠WARNING!!

All electrical work should be carried out by an authorized electrician, in compliance with the laws and wiring codes of the locale where the work is being performed. Performance by an unauthorized person is against the law, and can be extremely dangerous.

Improper wiring can lead to current leakage, electrical shock, or fire.

Be sure to use a ground leakage breaker and an overcurrent protector (or breaker) to prevent damage to the pump that may lead to electrical shock.

Be sure that the power supply and wiring have adequate capacity.

Grounding

⚠WARNING!!

To prevent damaging the pump and causing current leakage, which may lead to electrical shock, be sure to install the ground wire securely.

⚠CAUTION!

To prevent electrical shock caused by improper grounding, do not connect the ground wire to a gas pipe, water pipe, lightning rod, or telephone ground wire.

Cabtyre Cable

⚠CAUTION!

If the cabtyre cable must be extended, use an extension cable with the same or larger core size as that of the cable that is provided with the pump. Using a cable of proper size will prevent the motor from attaining its full potential or may cause the cable to overheat, which may lead to fire, current leakage, or electrical shock.

If a cabtyre cable with a cut or damaged sheath is submerged in water, the water may enter the pump and cause the motor to short. This will damage the pump, which may lead to current leakage, electrical shock, or burn-out.

To prevent the cable from cuts or twists, which will damage the pump and may lead to current leakage, electrical shock, or fire, be sure that the tires of vehicles do not run over the cabtyre cable.

If the cabtyre cable must be submerged in water, be sure to mold the connection portion completely. Failure to do so may lead to current leakage, electrical shock, or burn-out.

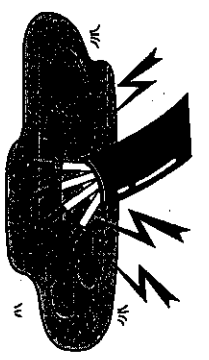

Never submerge the ends of a cabtyre cable in water.

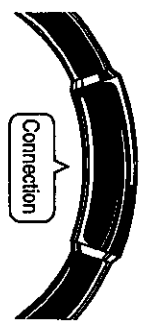

To prevent water from entering inside the cable, be sure to securely mold the cable connection portion.

Connecting the Cabtyre Cable

⚠WARNING!!

Before connecting the cabtyre cable to the terminal board, make sure that the power supply (i.e. circuit breaker) is properly disconnected. Failure to do so may lead to electrical shock, short, or injury caused by the unintended starting of the pump.

(1) Tighten the ends of the cabtyre cable securely against the terminal board.

(2) The figure on the right shows how to connect the cabtyre cable properly.

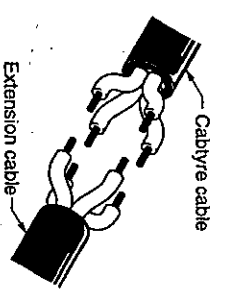

If the cabtyre cable must be extended, use an extension cable with the same or larger core size as that of the cable that is provided with the pump.



To avoid damaging the cable, arrange the cable run so that the cable is not bent, kinked, or pressed against a structure.

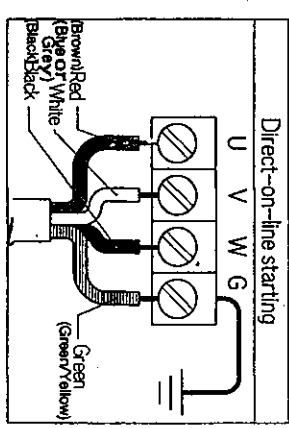

Wiring Diagram

Direct-on-line starting

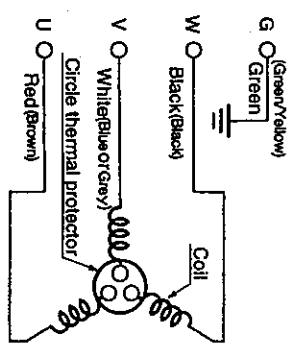

5 Operation

Before Operation

⚠ CAUTION!

Improper voltage and frequency of the power supply will prevent the pump from attaining its full potential, and may also lead to current leakage, electrical shock, or fire.

- (1) Once again, check the nameplate of the pump to verify that its voltage and frequency are correct.

- (2) Check the wiring, power supply voltage, the capacity of the ground leakage circuit breaker, and the insulation resistance of the motor.

■ Insulation resistance reference value = 20MΩ min.

- (3) Adjust the setting of the overflow protector (i.e. circuit breaker) to the pump's rated current.

NOTE: Verify the rated current on the pump's nameplate.

- (4) When using a generator, as much as possible avoid operating the pump in conjunction with other types of equipment.

Trial Operation

⚠ WARNING!!

- Never start the pump while it is suspended, as the pump may jerk and cause a serious accident involving injury.
- Never start the pump where people are present, as they may suffer electrical shock from current leakage.

⚠ CAUTION!

Be sure to check the pump's direction of rotation when the pump is exposed to atmosphere. Operating the pump in reverse while it is submerged in water will damage the pump, which may lead to current leakage, electrical shock, or fire.

- (1) Operate the pump for a short time (1 to 2 seconds), and then use a phase rotation indicator to check the rotational direction of the impeller.

NOTE: When using a phase rotation indicator, read the operation manual that is provided with it.

⚠ WARNING!!

Before changing the connections for reverse rotation, make sure that the power supply (i.e. circuit breaker) is properly disconnected and that the impeller has stopped completely. Failure to observe this may lead to serious accidents, including electrical shock, short, or injury.

- To reverse the rotation, the following countermeasure must be taken.

[COUNTERMEASURE]
Interchange two of the three wires designated U, V, and W, respectively.

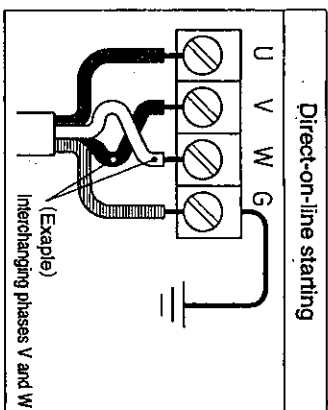

- (2) Operate the pump for a short time (3 to 10 minutes) and perform the following checks:

- Operating current
Using an AC ammeter (clamp), measure the current at the phases U, V, and W that are connected to the terminal board.

[COUNTERMEASURE]

Because an overload condition may be present at the motor if the operating current exceeds the rated current, refer to the section "3. Installation" on page 3 of this manual for procedures on reverting the motor to the correct state.

- Operating voltage

Use an AC voltmeter (tester) to measure the voltage at the terminal board.

- Power supply voltage tolerance = within ±5% of the rated voltage

[COUNTERMEASURE]

If the power supply voltage deviates from the tolerance value, the deviation may be caused by the capacity of the power supply or the extension cable that is used. Refer to the section "4. Electrical Wiring" on page 6 of this manual to provide correct voltage.

- Vibration

⚠ CAUTION!

If the pump generates a considerable amount of vibration, noise, or smell, disconnect the power supply immediately and contact the dealer where you purchased the equipment, or the Tsurumi sales office in your area.

Continue operation if no abnormal conditions are found during the trial operation.

Operation

CAUTION!

- The pump may be extremely hot during operation. To prevent burns, do not touch the pump with bare hands.
- Do not insert your finger or a stick into the pump's inlet opening. Doing so may cause injury, electrical shock, short, or fire.
- When the pump is not used for a long time, make sure that the power supply (such as a breaker) is properly disconnected. If the wiring insulation deteriorates with the power supply connected, it may cause current leakage, electrical shock, or fire.

Pay attention to the water level during the pump operation. The pump will become damaged if it is allowed to operate dry.

NOTE: Refer to the section "Water Level During Operation" on page 11 of this manual.

The pump is equipped with an internal motor protective device (circle thermal protector).

Circle Thermal Protector

WARNING!!

- During inspection and repair, disconnect the power supply to avoid starting the pump unintentionally. Failure to disconnect the power supply may lead to serious accidents including electrical shock, short, and injury.
- During a power outage, disconnect the power supply to the pump. Unintentional operation of the pump after power resumption would be extremely dangerous to people around the pump.

CAUTION!

- Unless the cause of a problem is removed, the pump will repeat the stop-and-go cycle, eventually resulting in damage to the pump, and causing current leakage and electrical shock. Therefore, after verifying that the power supply is disconnected, find and correct the cause of the problem through inspection and repair.
- Do not operate the pump at unusually low head, or when the strainer is clogged with debris. Doing so will prevent the pump from attaining its full potential, and may also generate abnormal noise and vibration and cause damage to the pump, which may lead to current leakage, electrical shock, and fire.

To protect the motor, if a current overload occurs in the motor or if the motor overheats under the conditions given below, the pump will stop automatically, regardless of the water level during operation.

- Extreme fluctuation of power supply voltage
- Pump operated under overload condition
- Pump operated at open phase or binding condition

Water Level During Operation

CAUTION!

Do not operate the pump below Continuous running Water Level (C.W.L.), as doing so will damage the pump, causing current leakage and electrical shock.

The table below shows the water level during operation by output. Make sure that the water level will not be under these levels.

M O D E L		C.W.L.
KTZ 215	KTZ 315	120 mm
KTZ 222	KTZ 322	
KTZ 237	KTZ 337	
KTZ 437	KTZ 355	150 mm
KTZ 455		
KTZ 475	KTZ 675	
KTZ 411	KTZ 611	190 mm

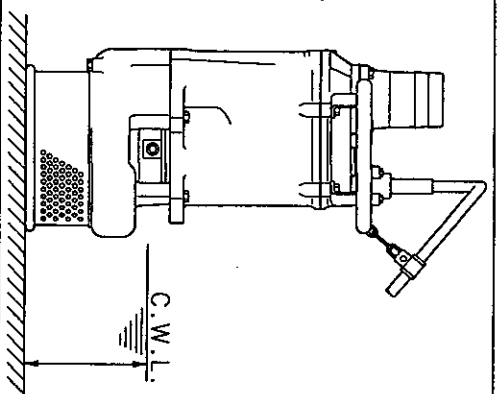

The diagram shows a cross-section of the pump assembly. A horizontal line labeled 'C.W.L.' (Continuous Running Water Level) is drawn across the pump's internal chamber. Below this line, there is a shaded area representing water. The pump's motor and other internal parts are shown above the water level.

6 MAINTENANCE AND INSPECTION

Periodic maintenance and inspection are indispensable in maintaining the pump's performance. If the pump behaves differently from its normal operating condition, refer to the section "8. Troubleshooting" on page 19 of this manual and take appropriate measures at an early stage.

We also recommend that you have a spare pump on hand.

Periodical Inspection

1. Before Inspection



WARNING!! Make sure that the power supply (i.e. circuit breaker) is disconnected, and remove the cable from the terminal board. Failure to do so may cause electrical shock or unintended starting of the pump, which may lead to serious injurious accidents

(1) Washing the Pump

Remove any debris attached to the pump's outer surface, and wash the pump with tap water. Pay particular attention to the impeller area, and completely remove any debris from the impeller.

(2) Inspecting the Pump Exterior

Verify that the paint is not peeled, that there is no damage, and that the bolts and nuts have not loosened. If the paint has peeled, allow the pump to dry and apply touch-up paint.

NOTE: Touch-up paint must be provided by the user. If the pump must be disassembled due to damage or loose bolts or nuts, contact the dealer from whom you purchased the equipment, or the Tsurumi sales office in your area.

Inspection Item

Interval	Inspection Item
Monthly	① Measuring insulation resistance ■ Insulation resistance reference value = 1MΩ min. NOTE: The motor must be inspected if the insulation resistance is considerably lower than that obtained during the last inspection. ■ To be within the rated current ② Measuring the loaded current ■ To be within the rated current ③ Measuring the power supply voltage ■ Power supply voltage tolerance = within ±5% of the rated voltage ④ Inspecting the impeller ■ If the performance level has decreased considerably, the impeller may be worn.
Semi-annually	① Inspecting and changing of ■ NOTE: Refer to the section "Oil Inspection and Change Procedures" on page 13 of this manual.
Yearly	① Changing the oil and replacing the mechanical seal in the oil chamber NOTE: Contact the dealer from whom you purchased the equipment, or the Tsurumi sales office in your area to inspect and replace the mechanical seal. NOTE: The pump must be overhauled even if the pump appears normal during operation. The pump may need to be overhauled earlier if it is used continuously or repeatedly. Contact the dealer from whom you purchased the equipment, or the Tsurumi sales office in your area to overhaul the pump.
Once every 2 to 5 years	① Overhaul

Storage

If the pump will not be operated for a long period of time, pull the pump up, allow it to dry, and store it indoors.

NOTE: Be sure to perform a trial operation before reinstalling the pump.

If the pump remains immersed in water, operate the pump on a regular basis (i.e. once a week) to prevent the impeller from seizing due to rust.

Oil Inspection and Changing Procedures

- Inspection Interval: Every 3,000 hours or 6 months, whichever comes first
- Changing Interval: Every 6,000 hours or 12 months, whichever comes first.
- Designated oil : Turbine oil VG32
- Oil volume : Specified volume (Refer to the table, "Specified Oil Volume")

Inspecting Oil

Remove the oil plug and take out a small amount of oil. The oil can be extracted easily by tilting the pump so that the oil plug faces downward. If the oil appears discolored or intermixed with water, a likely cause is a defective shaft sealing device (i.e. mechanical seal), which requires that the pump be disassembled and repaired.

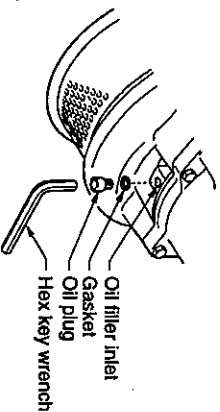

Changing Oil

Remove the oil plug and drain the oil completely. Pour a specified volume of oil into the oil filler inlet.

- NOTE: • The drained oil must be disposed of by waste disposal contractors in compliance with the laws of the locale where the pump is being used.
- The gasket and the O-ring for the oil filler plug must be replaced with a new part at each oil inspection and change.

Model	Specified oil volume (ml)
KTZ 215	740
KTZ 222	KTZ 315 KTZ 322
KTZ 237	KTZ 337
KTZ 437	1,200
KTZ 455	KTZ 365
KTZ 475	KTZ 675
KTZ 411	KTZ 611
	760

Maintenance

The parts listed below are dispensable items. As a rule of thumb, use the replacement period as a guide to replacing these parts.

Part name	Replacement condition
Mechanical seal	Lubrication oil discolored
Lubrication oil (turbine oil VG32)	Every 6,000 hours or 12 months, whichever comes first
Gasket and O-ring	Each disassembly or inspection
Oil seal (1.5 to 5.5 kW)	Each disassembly or inspection or if the sealing lip is worn
Labyrinth ring (7.5/11 kW)	When worn
Shaft sleeve (except 3.7/5.5 kW)	When worn

7 DISASSEMBLY AND REASSEMBLY PROCEDURE

⚠ WARNING!!

Prior to Disassembling and Reassembling the pump, be sure that the power supply (i.e. circuit breaker) is disconnected, and remove the cable from the terminal board. To prevent serious accidents, do not perform a conducting test during disassembly and reassembly.

Be sure to perform a trial operation when starting the pump after a reassembly. If the pump was assembled improperly, it may lead to abnormal operation, electrical shock, or water damage.

⚠ CAUTION!

This section explains the disassembly and reassembly processes that are involved up to the casing (or oil casing, in the case of 7.5 kW and 11 kW models). Refer to the structural drawing for the respective model before disassembling. Operations involving the disassembly and reassembly of the sealing portion (i.e. mechanical seal) and of the motor require a specialized facility including vacuum and electrical equipment. For these operations, contact the dealer from whom you purchased the equipment, or the Tsunami sales office in your area.

Disassembly Procedure for KTZ21.5

NOTE: Before disassembling, be sure to drain the oil from the pump. Models KTZ22.2, KTZ23.7, KTZ31.5, KTZ32.2, KTZ 33.7, KTZ35.5, KTZ43.7, and KTZ45.5 have the same construction. However, models KTZ23.7, KTZ33.7, KTZ35.5, KTZ 43.7, and KTZ45.5 are constructed without a shaft sleeve.

- (1) Removing the strainer stand
Remove the hexagonal nut and the plain washer from the bottom and remove the strainer stand from the pump.
- (2) Removing the suction cover
Remove the hexagonal bolt (except 1.5/2.2 kW), plain washer, and the stud bolt, plain washer, and remove the suction cover, suction cover packing from the pump.
- (3) Removing the impeller

⚠ WARNING!!

A worn impeller often has sharp edges. Be careful not to cut yourself on the edges.

Using a box wrench, remove the impeller nut, spring washer, and impeller thread protective cover, then remove the impeller, impeller adjusting washer, shaft sleeve (except 3.7/5.5 kW) from the main shaft.

- (4) If necessary, remove the pump casing, oil seal, O-ring, packing and remove the mechanical seal. After removing the hexagonal bolt and the spring washer, remove the pump casing from the pump. At this time, be careful not to damage the sliding surface of the mechanical seal. Remove the mechanical seal from the main shaft.

NOTE: Also refer to the "Mechanical Seal Handling Procedure" that comes with the mechanical seal sold separately as a spare part.

Reassembly Procedure

- (1) The reassembly procedure is the reverse sequence of disassembly.

NOTE: • After completing reassembly, do not forget to pour the specified amount of oil into the pump.

- The gaskets and O-rings must be replaced with new parts. Also replace any parts that are worn or damaged.

- (2) Using a clean rag without oil, wipe the sliding surface of the mechanical seal. Apply oil to the outer circumference of the cushion rubber to facilitate insertion.

NOTE: For further details on how to install the mechanical seal, refer to the "Mechanical Seal Handling Procedure" that comes with the mechanical seal that is sold separately as a spare part.

- (3) After installing the impeller, and after completing the reassembly, check that the impeller rotates smoothly and that it does not come in contact with the suction cover.

NOTE: The suction cover has a padded part (partly thicker area) at the backside of it. When installing the suction cover to the pump casing, place the suction cover so that the padded part may be located nearest to the discharge area of the pump casing. This may extend the wearing life of the suction cover.

- (4) To make sure that the pump operates normally, perform a trial operation before placing the pump back into service. 15 -

KTZ 21.5

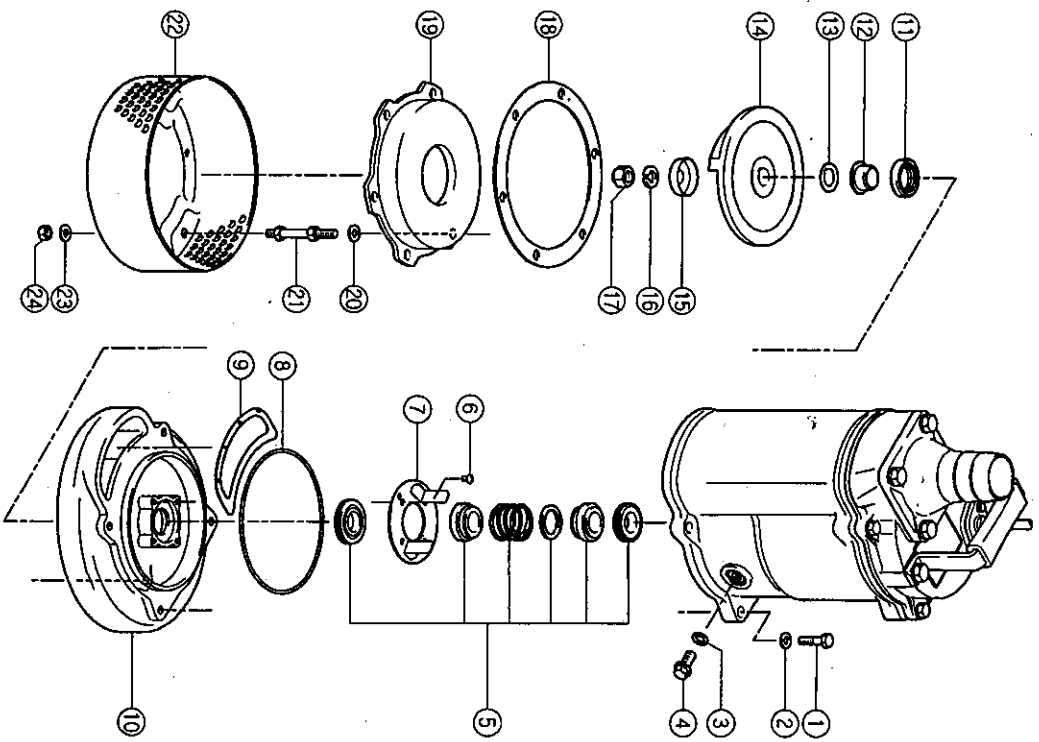

NO.	Part Name	NO.	Part Name	NO.	Part Name
1	Hexagonal bolt	9	Gasket	17	Impeller nut
2	Spring washer	10	Pump casing	18	Suction cover gasket
3	Packing	11	Oil seal	19	Suction cover
4	Oil plug	12	Shaft sleeve	20	Plain washer
5	Mechanical seal	13	Impeller adjusting washer	21	Stud bolt
6	Round head screw	14	Impeller	22	Strainer stand
7	O-ring	15	Impeller thread protective cover	23	Plain washer
8	O-ring	16	Spring washer	24	Hexagonal nut

Disassembly Procedure for KTZ47.5

NOTE: Before disassembling, be sure to drain the oil from the pump. Models KTZ67.5, KTZ411, and KTZ611 have the same construction.

- (1) Removing the bottom plate and the strainer
After removing the hexagonal nut and the plain washer from the bottom, remove the bottom plate and the strainer from the pump.
- (2) Removing the suction cover
After removing the hexagonal bolt, plain washer, stud bolt, and the plain washer, remove the suction cover and the suction cover packing from the pump.
- (3) Removing the impeller
Using a box wrench, remove the impeller nut, hexagonal nut, and the impeller thread protective cover, then remove the impeller and the impeller adjusting washer from the main shaft.

WARNING!! A worn impeller often has sharp edges. Be careful not to cut yourself on the edges.

- (4) Removing the pump casing
After removing the hexagonal bolt and the spring washer, remove the pump casing, packing, labyrinth ring, O-ring, and the shaft sleeve from the pump.
- (5) Remove the oil casing if necessary, and remove the mechanical seal.
After removing the hexagonal bolt and the spring washer, remove the oil casing from the pump. At this time, be careful not to damage the sliding surface of the mechanical seal. Remove the mechanical seal from the main shaft.

NOTE: Also refer to the "Mechanical Seal Handling Procedure" that comes with the mechanical seal that is sold separately as a spare part.

Reassembly Procedure

- (1) The reassembly procedure is the reverse sequence of disassembly.
NOTE: • After completing reassembly, do not forget to pour the specified amount of oil into the pump.
• The gaskets and O-rings must be replaced with new parts. Also replace any parts that are worn or damaged.
- (2) Using a clean rag without oil, wipe the sliding surface of the mechanical seal. Apply oil to the outer circumference of the cushion rubber to facilitate insertion.
NOTE: For further details on how to install the mechanical seal, refer to the "Mechanical Seal Handling Procedure" that comes with the mechanical seal that is sold separately as a spare part.
- (3) After installing the impeller, and after completing the reassembly, check that the impeller rotates smoothly and that it does not come in contact with the suction cover.
NOTE: The suction cover has a padded part (partly thicker area) at the backside of it. When installing the suction cover to the pump casing, place the suction cover so that the padded part may be located nearest to the discharge area of the pump casing. This may extend the wearing life of the suction cover.
- (4) To make sure that the pump operates normally, perform a trial operation before placing the pump back into service.

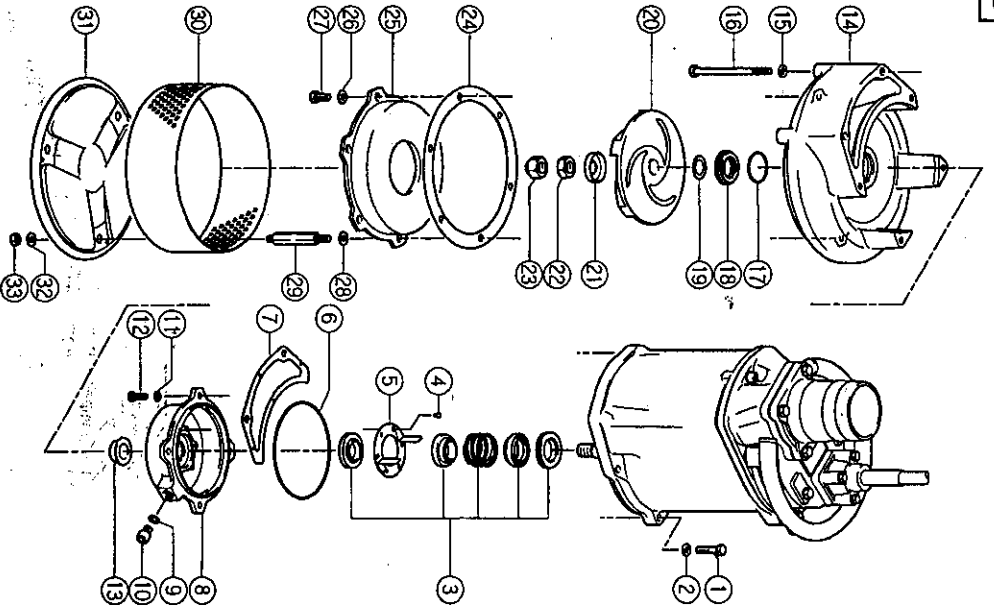

NO.	Part Name	NO.	Part Name	NO.	Part Name
1	Hexagonal bolt	12	Hexagonal bolt	23	Impeller nut
2	Spring washer	13	Shaft sleeve	24	Suction cover gasket
3	Mechanical seal	14	Pump casing	25	Suction cover
4	Round head screw	15	Spring washer	26	Plain washer
5	Oil ring	16	Hexagonal bolt	27	Hexagonal bolt
6	O-ring	17	O-ring	28	Plain washer
7	Packing	18	Labyrinth ring	29	Stud bolt
8	Oil casting	19	Impeller adjusting washer	30	Strainer
9	Gasket	20	Impeller	31	Bottom plate
10	Oil plug	21	Impeller thread protective cover	32	Plain washer
11	Spring washer	22	Hexagonal nut	33	Hexagonal nut

8 TROUBLESHOOTING

⚠WARNING!! To prevent serious accidents, disconnect the power supply before inspecting the pump.

Read this Operation Manual carefully before requesting repair. After re-inspecting the pump, if it does not operate normally, contact the dealer from whom you purchased the equipment, or the Tsunami sales office in your area.

