

AQUA COOLER PTY LIMITED

A.C.N. 002 911 524
A.B.N. 13 245 994 351
14-16 MARJORIE STREET
SEFTON NSW 2162
Ph: (612) 9743 9233
Fax: (612) 9743 9244
Email: coolers@aquacooler.com.au

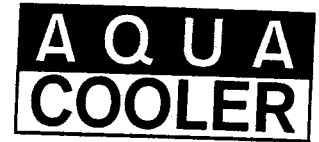

MANUFACTURERS OF[®]
WATER COOLERS AND
INDUSTRIAL CHILLERS

SERVICE MANUAL MAINS CONNECTED COOLERS

Enclosed is:

- Installation Instructions
- M Series Exploded View
- Changing a filter
- Filter changing procedure
- Typical Installation - drain
- Bubbler & Glass filler exploded view
- Cleaning Instructions
- Warranty sheet

PROUDLY AUSTRALIAN

AQUA COOLER PTY LIMITED

A.C.N. 002 911 524
14-16 MARJORIE STREET
SEFTON NSW 2162
Ph: (612) 9743 9233
Fax: (612) 9743 9244



MANUFACTURERS OF
WATER COOLERS AND
INDUSTRIAL CHILLERS

AQUA COOLER OWNERS MANUAL **M4, M5, M4E, M5E, M10, M10F, M11, M11F, WM2, WM3**

INSTALLER

To ensure you install the unit easily and correctly, PLEASE READ THE FOLLOWING INSTRUCTIONS BEFORE STARTING INSTALLATION. CHECK YOUR INSTALLATION FOR COMPLIANCE WITH PLUMBING, ELECTRICAL AND OTHER APPLICABLE CODES. After installation, leave these instructions inside the cooler for future reference.

IMPORTANT

All service to be performed by an authorised service person.

1. Ensure proper ventilation by maintaining 75mm clearance on each side of the cooler.
2. Water supply 15mm FBSP, Waste 40mm PVC Socket. Contractor to supply 40mm waste trap, fittings and a mains water isolating valve in accordance with local codes.
NOTE: A pressure reduction valve must be fitted if mains water is in excess of 700kPa.
3. Minimum water pressure for cooler operation, 100kPa.
4. Connecting lines should be thoroughly flushed to remove all foreign matter before connection to the cooler.
5. Ensure electrical power supply is identical in voltage, cycle and phase to that specified on the the cooler data plate. NEVER wire compressor directly to the power supply.
6. To add a glass filler to a bubbler only unit - fit a glass filler conversion kit supplied by and especially designed for unit conversion by Aqua Cooler Pty Limited.

WARNING: - Warranty is voided if:

- The plumbing kit or glass filler is not specified for use by Aqua Cooler for this particular model.
- Installation is not made in accordance with current Aqua Cooler instructions.

INSTALLATION OF COOLER

1. Install a nominal 15mm OD Water line between the mains water isolating valve and the cooler as shown in either Figure 1a (for "M" Series) or 1b (for "WM" Series).
2. Install the 40mm waste trap from the drain connection on the cooler as shown in Figure 1a (for "M" Series) or 1b (for "WM" Series).

START UP

1. Turn on the building water supply and check all connections for leaks.
2. Depress the bubbler button until all air is bled from cooler water system. A steady flow assures all air has been removed.
3. Stream height of water is factory set at 300-350 kPa. If supply pressure varies greatly from this, adjust the stream height to approximately 40mm above the bubbler guard by turning the adjustment screw, accessible by removing the hex cover nut and bubbler button, see Figure 2.
4. Re-check all water and drain connections for leaks with water flowing through the system.
5. Plug cooler power cord into building electrical receptacle.

Trouble Shooting & Maintenance

1. Bubbler: If mineral deposits build up in the orifices, they can be removed by using a round file or small diameter wire. CAUTION: Care must be taken not to damage the orifices.
2. Stream Regulator: To adjust stream height see instruction No.3 under "Start Up" section.
3. Temperature control: Factory set for 10°C water under normal conditions (Do not alter).
4. Ventilation: Condenser fins should be periodically cleaned with a brush, air hose or vacuum cleaner.
5. Lubrication: Motors are lifetime lubricated.

NOTE: If the flexible electric supply cord is damaged, it must be replaced by the manufacturer or service agent or similarly qualified person in order to avoid hazard.

PROUDLY AUSTRALIAN

WOLFA COOLER OWNER'S MANUAL
REFRIGERATED - THERMINS PRESSURE COOLER
EXPERIMENTAL WARE

Not Shown:
 Front door
 Filter for "F" models
 Two part door for "F" models

Z-1202
 Z-8000
 Z-1204 upper
 Z-1205 lower

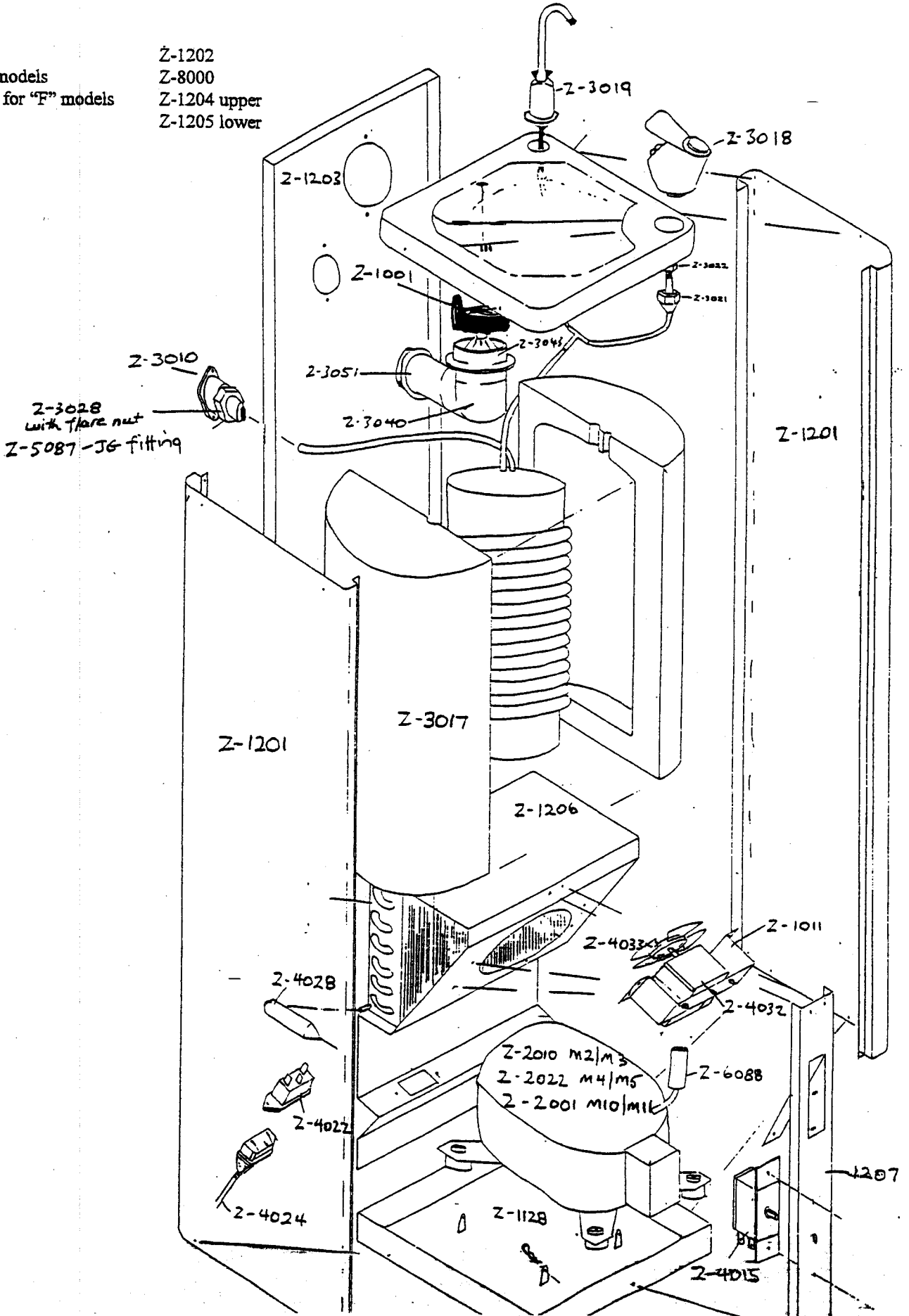

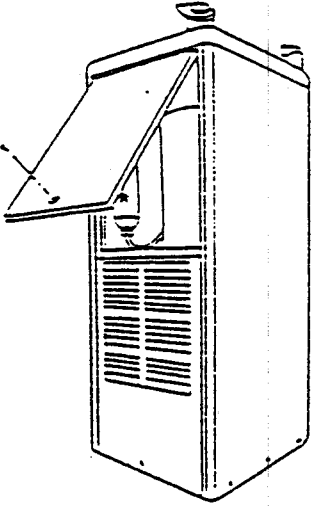

1. Remove screw and pull panel down.

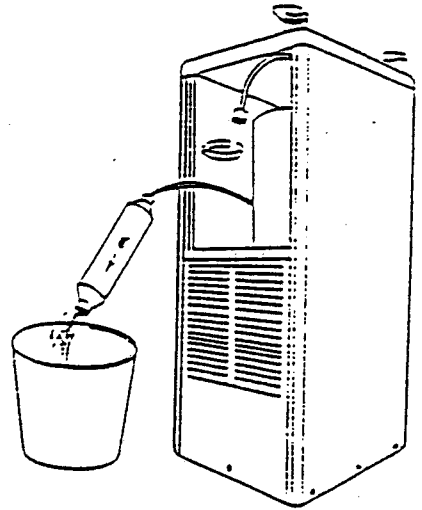

2. Turn mains water off at rear of cooler, remove filter, unscrew outlet and drain into bucket, unscrew inlet. Remove old filter.

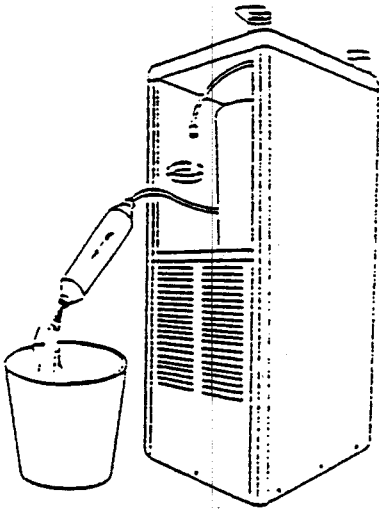

3. Screw inlet hose to "in" coupling of new filter, turn mains water on, flush filter into bucket until water is clear.

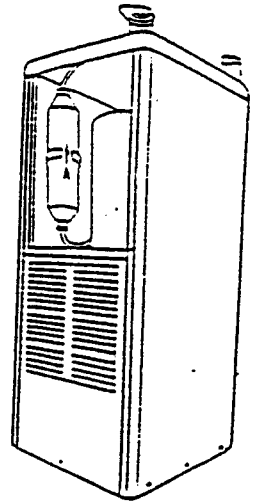

4. Turn off mains water, screw outlet hose to cut coupling of filter. Re-install filter and turn on mains water.

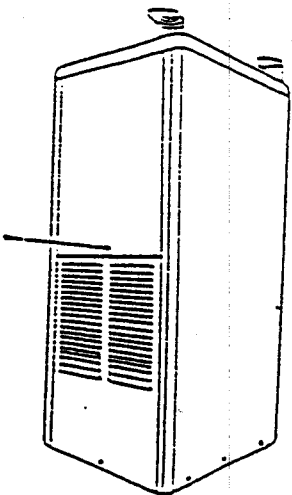

5. Check water is not leaking from filter, fit panel to machine and secure lower screw.

Replacement Cartridge
Code No C-118

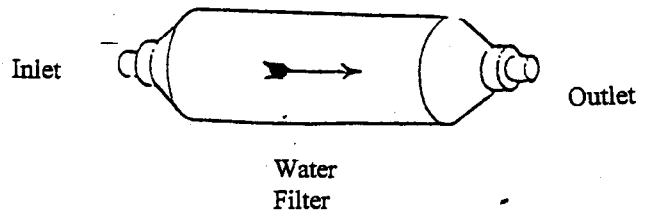

CAUTION
BOTTOM DOOR TO BE REMOVED
BY QUALIFIED PERSONNEL

Tools required:
Small shifting spanner or 1/2 AF spanner.

To change a filter

1. Switch off the water cooler at the power outlet and remove plug from same.
2. Turn off the water supply to unit.
3. Remove the upper front door using a screw driver. Warning: The lower front door is to be removed by only a suitably qualified person.
4. Remove C-clip from collet fittings on each end of filter.
5. Simply push in collet to release tube from on each end of the filter.
6. Remove filter from cabinet.
7. Remove fittings from filter ends and using teflon tape insert them into the new filter.
8. Re-locate new filter into cabinet and slide water supply tube into inlet end as far as possible.
9. Ensure flow direction is correct.
10. Re-connect power supply.
11. Turn water supply on and allow to flush into a bucket or waste for 5 minutes or until water is clear, as some carbon will initially flow through.
12. When water is clear, connect outlet end of filter to unit.
13. Change filter at least every six months.

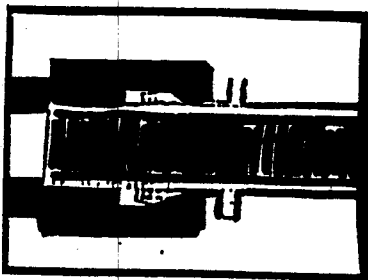

Tube is secured in position

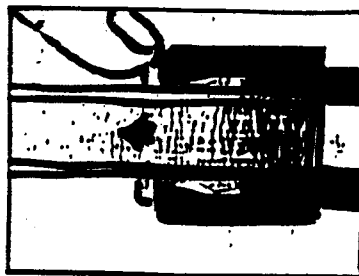

Push in collet to release tube

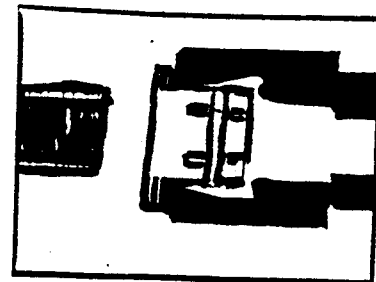

Simply push in tube to attach

Warning: In high sediment areas, frequent filter replacement may apply.

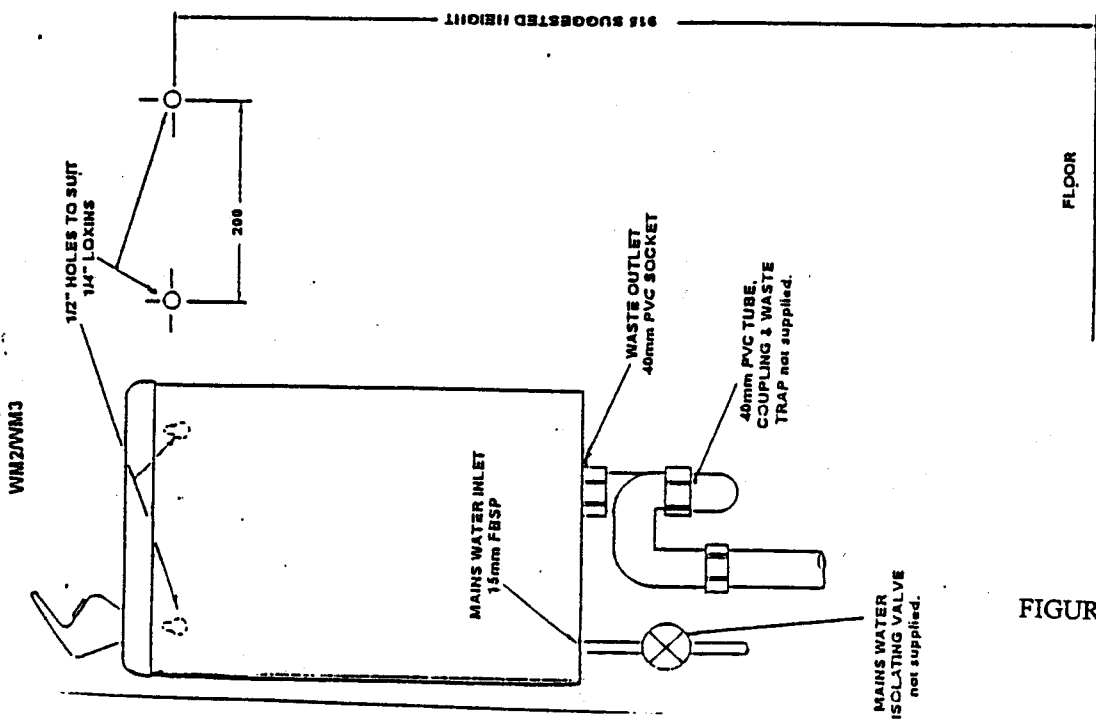
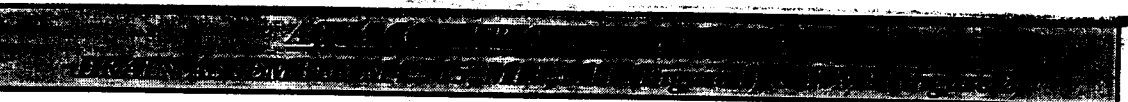

FIGURE 2

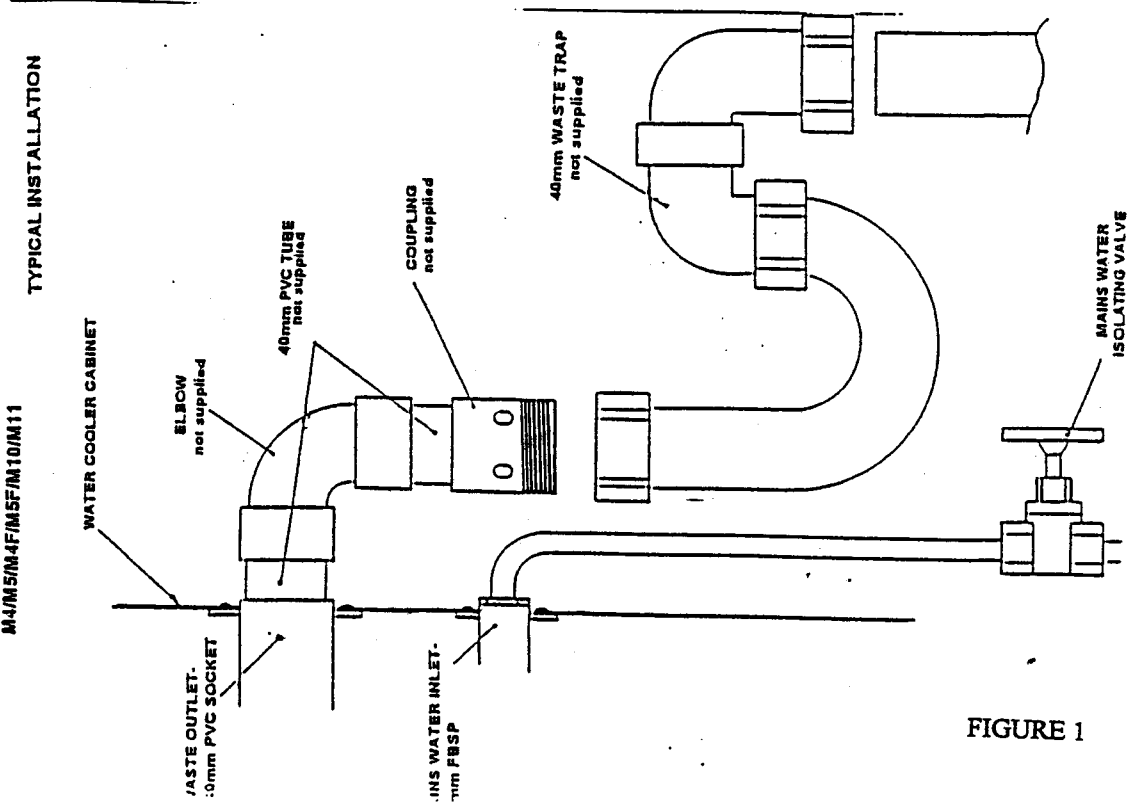

FIGURE 1

M4/M5/M4F/M5F/M10/M11

TYPICAL INSTALLATION

WN2/WM3

FLOOR

915 SUGGESTED HEIGHT

200

1/2" HOLES TO SUIT
1/4" LOKINGS

WASTE OUTLET
40mm PVC SOCKET

40mm PVC TUBE,
COUPLING & WASTE
TRAP not supplied.

MAINS WATER
ISOLATING VALVE
not supplied.

MAINS WATER INLET
15mm FBSP

WATER COOLER CABINET

ELBOW
not supplied

40mm PVC TUBE
not supplied

COUPLING
not supplied

40mm WASTE TRAP
not supplied

MAINS WATER
ISOLATING VALVE

WASTE OUTLET
40mm PVC SOCKET

MAINS WATER INLET
15mm FBSP

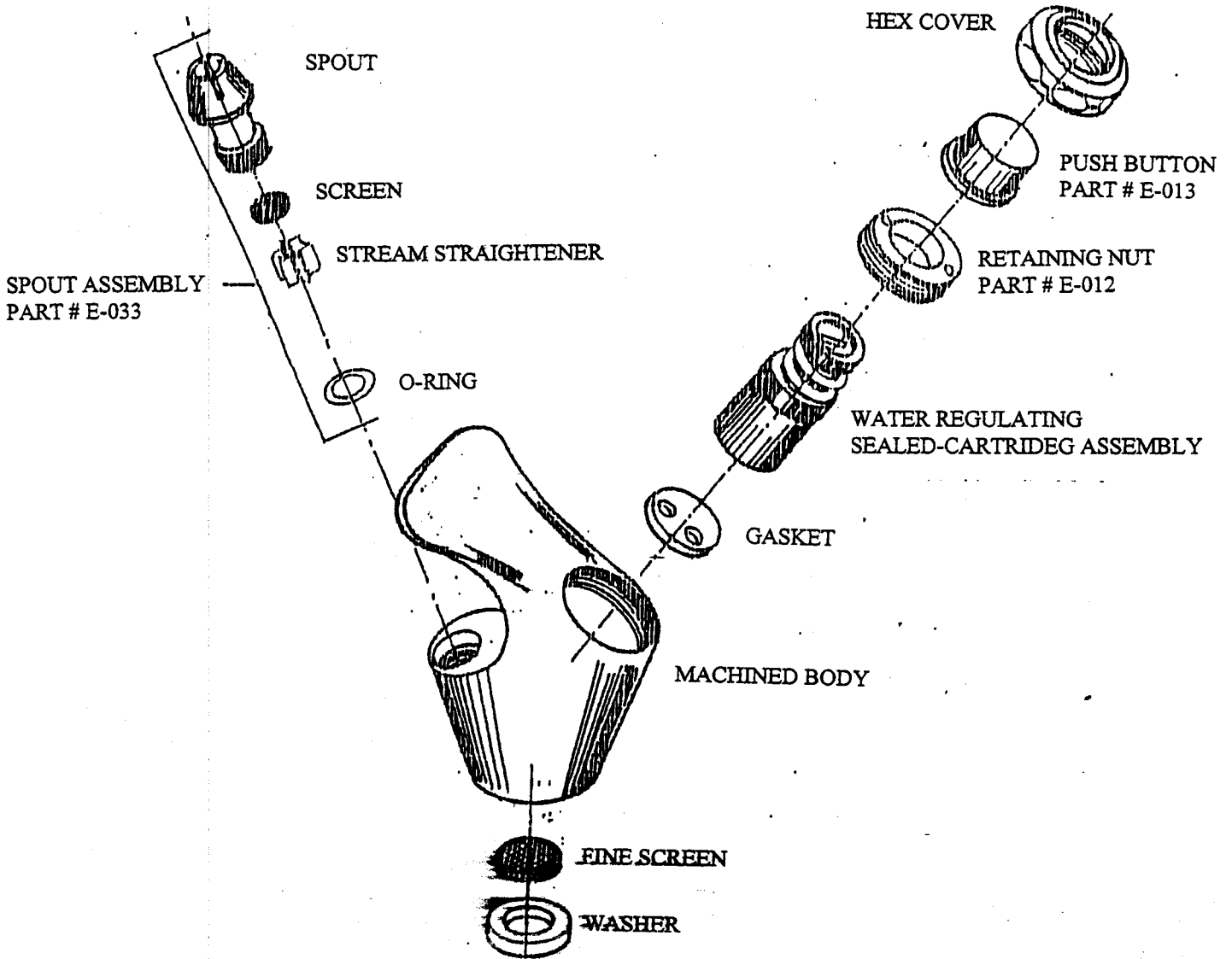
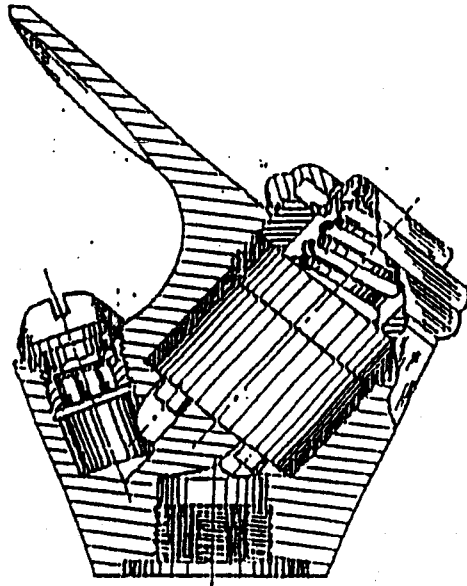

AQUA GOOSE FAUCET OWNER'S MANUAL
CLASSIC CARAFFE FILTERS EXCLUDED

A single handle faucet, that permits fingertip control of flow and which flips up for constant flow, is available in a wide range of flow rates (see curves on other side) and with a variety of gooseneck designs.

Gleaming chromium plate (over nickel plate) on heavy brass, 1/4" long threaded brass nipple, for 1/4" compression connection and stainless steel valve seat assure good appearance and long life.

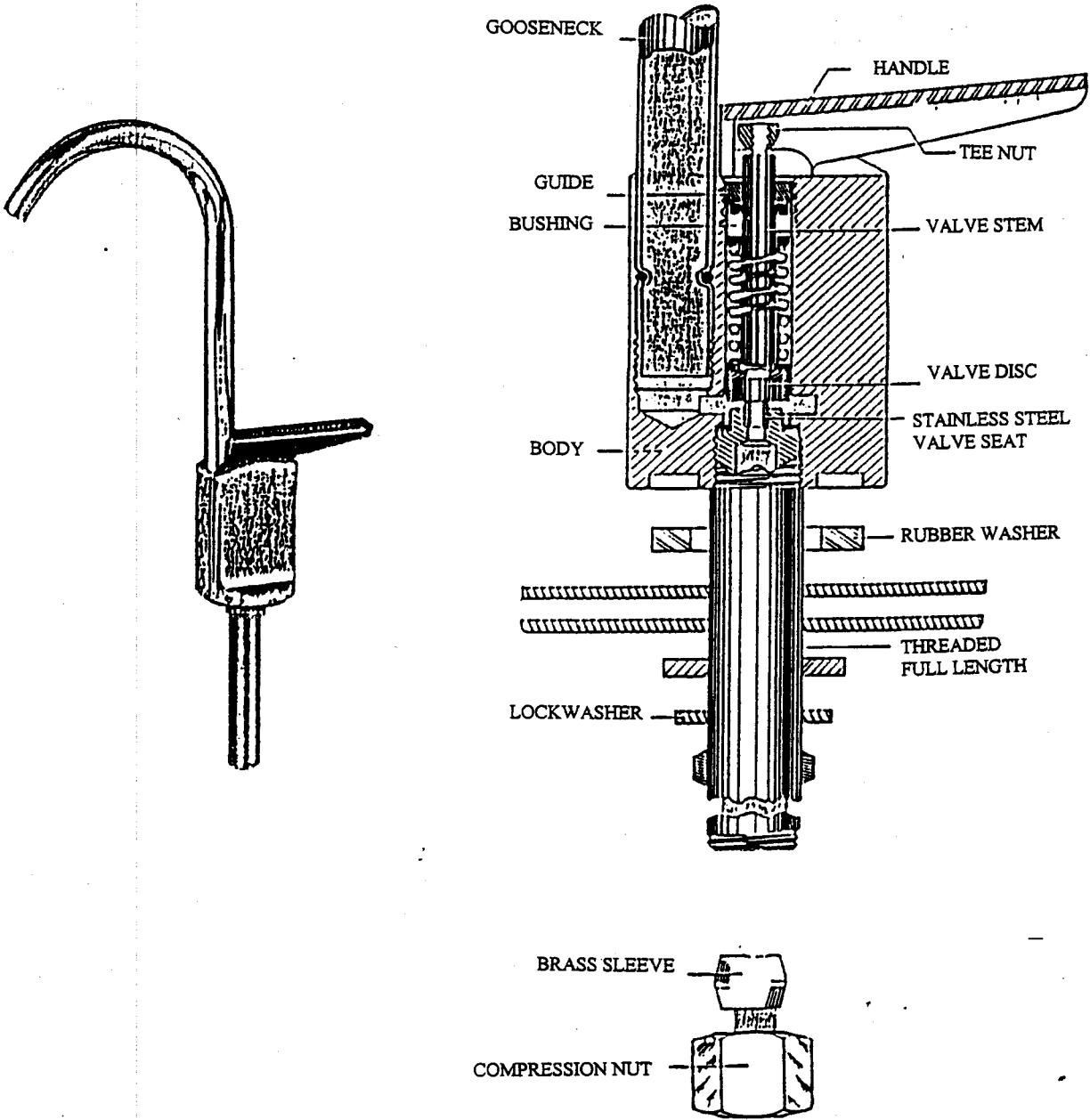

COMPLAINT	POSSIBLE CAUSE	REPAIR
Compressor will not start - no hum.	<ol style="list-style-type: none"> 1. Line disconnect switch open. 2. Fuse removed or blown. No power. 3. Overload protector tripped. 4. Thermostat stuck in open position. 5. Thermostat off due to cold location. 6. Wiring improper or loose. 7. High or low pressure control open. 	<ol style="list-style-type: none"> 1. Close start or disconnect switch. 2. Replace fuse. Check reason. 3. Refer to electrical section. 4. Repair or replace control. 5. Relocate control. 6. Check wiring against diagram. 7. Check system pressures against control settings.
Compressor will not start - hums but trips on overload protector.	<ol style="list-style-type: none"> 1. Improperly wired. 2. Low voltage to unit. 3. (a) Start capacitor defective on CSIR or CSR motor. 3. (b) Run capacitor defective on PSC motor. 4. Relay failing to close. 5. Compressor motor has a winding open or shorted. 6. Internal mechanical trouble in compressor. 	<ol style="list-style-type: none"> 1. Check wiring against diagram. 2. Determine reason and correct. 3. (a) Determine reason and replace. 3. (b) Determine reason and replace. 4. Determine reason and correct. Replace if needed. 5. Check resistance values. Replace compressor if necessary. 6. Replace compressor.
Compressor starts, but does not switch off start winding.	<ol style="list-style-type: none"> 1. Improperly wired. 2. Low voltage to unit. 3. Relay failing to open due to welded contacts or relay incorrectly mounted. 4. Run capacitor defective on CSR motor. 5. Excessively high discharge pressure. 6. compressor motor has a winding open or shorted. Check continuity and resistance. 7. Internal mechanical trouble in compressor (tight). May be lubrication. 	<ol style="list-style-type: none"> 1. Check wiring against diagram. 2. Determine reason and correct. 3. Determine reason and correct, replace if necessary. 4. Determine reason and replace. 5. (a) Check pressure at discharge service valve or (b) (No service valve). Check power input watts. Possible overcharge, insufficient condenser cooling, or non-condensable gases. 6. Replace compressor if faulty. 7. Replace compressor. Check system design for possible oil logging or system floodback.
Compressor starts and runs but short cycles on overload protector. (Relay may chatter on RSIR, CSIR and CSR motors).	<ol style="list-style-type: none"> 1. Additional current passing through overload protector. 2. Low voltage to unit (or unbalanced if three phase). 3. Overload protector defective. 4. Run capacitor defective on CSR motor. 5. Excessive discharge pressure. 6. Suction pressure too high. 7. Compressor too hot - insufficient suction gas cooling. 8. Compressor motor has a winding shorted. 	<ol style="list-style-type: none"> 1. Check wiring diagram. Check for added fan motors, pumps etc, connected to wrong side of protector. 2. Determine reason and correct. 3. Check current, replace protector. 4. Determine reason and replace. 5. Check ventilation, restrictions in cooling medium, restrictions in refrigeration system. 6. Check for possibility of misapplication or fit crankcase pressure regulator. 7. Check refrigerant charge (fix leak), add if necessary. Check return vapour temperature and suction superheat. 8. Replace compressor.

COMPLAINT	POSSIBLE CAUSE	REPAIR
Unit runs O.K. but short cycles on.	<ol style="list-style-type: none"> 1. Overload protector. 2. Thermostat. 3. High pressure cut-out due to : <ol style="list-style-type: none"> (a) Insufficient air or water supply. (b) Overcharge. (c) Air in system. 4. Low pressure cut-out due to : <ol style="list-style-type: none"> (a) Liquid line solenoid leaking. (b) Compressor discharge valve leak. (c) Undercharge. (d) Restriction in expansion device. 	<ol style="list-style-type: none"> 1. See D above. 2. Differential set to close - widen. 3 <ol style="list-style-type: none"> (a) Check air or water supply to condenser. (b) Reduce refrigerant charge. (c) Purge. 4 <ol style="list-style-type: none"> (a) Replace. (b) Replace compressor. (c) Fix leak, add refrigerant. (d) Replace device.
Unit operates long or continuously. Unsatisfactory space temp.	<ol style="list-style-type: none"> 1. Shortage of refrigerant. Capillary systems. 2. Control contacts stuck or space temperature to low. 3. Refrigerated or air conditioned space has excessive load or poor insulation. 4. System inadequate to handle load. 5. Evaporator coil iced. 6. Restriction in refrigeration system. 7. Dirty condenser. 8. Filter dirty. 	<ol style="list-style-type: none"> 1. Fix leak, add charge. 2. Clean contacts or replace control. 3. Determine fault and correct. 4. Replace with larger system. 5. Defrost. Check control settings. 6. Determine location and remove. 7. Clean condenser. 8. Clean or replace.
Start capacitor open, shorted or blown.	<ol style="list-style-type: none"> 1. Relay contacts not opening properly. 2. Prolonged operation on start cycle due to : <ol style="list-style-type: none"> (a) Low voltage to unit. (b) Improper relay. (c) Starting load to high. 3. Excessive short cycling. 4. Improper capacitor. 	<ol style="list-style-type: none"> 1. Clean contacts or replace relay if necessary. 2 <ol style="list-style-type: none"> (a) Determine reason and correct. (b) Replace. (c) Correct by using pump down arrangement if necessary. 3. Determine reason for short cycling (E above), and correct. 4. Determine correct size and replace.
Run capacitor open, shorted or blown.	<ol style="list-style-type: none"> 1. Improper capacitor. 2. Excessively high line voltage (110% of rated maximum). 	<ol style="list-style-type: none"> 1. Determine correct size and replace. 2. Determine reason and correct.
Relay defective or burned out.	<ol style="list-style-type: none"> 1. Incorrect relay. 2. Incorrect mounting angle. 3. Line voltage too high or too low. 4. Excessive short cycling. 5. Relay being influenced by loose vibrating mounting. 6. Incorrect run capacitor. 	<ol style="list-style-type: none"> 1. Check and replace. 2. Remount relay in correct position. 3. Determine reason and correct. 4. Determine reason (see E above) and correct. 5. Remount rigidly. 6. Replace with proper capacitor.
Space temperature too high.	<ol style="list-style-type: none"> 1. Control setting too high. 2. Expansion valve too small. 3. Cooling coils too small. 4. Inadequate air circulation. 5. Shortage of refrigerant. 	<ol style="list-style-type: none"> 1. Reset control. 2. Use larger valve. 3. Add surface or replace. 4. Improve air movement. 5. Find leak, add charge.

COMPLAINT	POSSIBLE CAUSE	REPAIR
Suction line frosted.	<ol style="list-style-type: none"> 1. Expansion valve passing excess refrigerant or is oversized. 2. Expansion valve stuck open. 3. Evaporator fan not running. 4. Overcharge of refrigerant capillary systems. 	<ol style="list-style-type: none"> 1. Re-adjust valve or replace with smaller valve. 2. Clean valve of foreign particles, replace if necessary. 3. Determine reason and correct. 4. Correct charge.
Liquid line frosted or sweating.	<ol style="list-style-type: none"> 1. Restriction in dehydrator or strainer. 2. Liquid shut-off (King valve) partially closed. 	<ol style="list-style-type: none"> 1. Replace part. 2. Open part fully.
Unit noisy.	<ol style="list-style-type: none"> 1. Loose parts or mountings. 2. Tubing rattle. 3. Bent fan blade causing vibration. 4. Fan motor bearings worn. 5. Liquid hammer from floodback or refrigerant migration. 	<ol style="list-style-type: none"> 1. Find and tighten. 2. Reform to be free of contact. 3. Replace blade. 4. Replace motor. 5. Check refrigerant flow control. Fit suction accumulator or crankcase oil heater.