

SIZE	INPUT MJ/H	INJECTOR mm		PRESSURE kPa	
		NG	LPG	NG	LPG
16	16	1.30 x 2	0.8 x 2	0.98	2.75
24	24	1.30 x 3	0.8 x 3	0.98	2.75
40	40	1.30 x 5	0.8 x 5	0.98	2.75
48	48	1.30 x 6	0.8 x 6	0.98	2.75

NOTE

Power Cord Requirement:
The Power Cord must be replaced with Aira Part No. RNZ 6022

FOR SERVICE PLEASE CONTACT AIRA

STATE	ADDRESS	PHONE	FAX
AIRA PTY LIMITED			
<u>AUSTRALIA</u>			
Victoria	144 Colchester Road KILSYTH 3137	(03) 9728 5566	(03) 9761 4732
N.S.W	3/36 Holbeche Road ARNDALL PARK 2148	(02) 9672 7555	(02) 9672 7556
South Australia	104 Coglin Street BROMPTON 5007	(08) 8346 5175	(08) 8340 1932
West Australia	5/15 Harvard Way CANNINGVALE 6155	(09) 455 2466	(09) 455 2599

ALASKON AIRA LIMITED

NEW ZEALAND	Unit B1/50 Keeling Road HENDERSON AUCKLAND	(09) 835 2100	(09) 835 2201
--------------------	--	---------------	---------------

PART NO. 5171
4/97

DESCRIPTION OF IGNITION SYSTEM: WE SUPER RAYS

The WEA series are fully automatic units featuring electronic ignition, continuous flame sensing, fail-safe operation and can be operated by a room thermostat. Units are supplied fitted with a 3 core flex and plug for which an earthed 10amp power outlet should be located within 1.5 metres of the right-hand side of the heater. If the unit is to be 'wired-in', an isolating switch must be provided. The gas flow to the burner(s) is via a twin solenoid valve operated by the control unit.

IGNITION PROCEDURE:

1. Turn power ON: (If fitted, turn room thermostat to desired setting).
2. When power is applied to the heater, the ignition unit will open the gas valves and commence spark generation to ignite the gas. If ignition does not take place within 7 seconds, the unit will close the gas valves and shut down, 'Lock-Out'.
3. If successful ignition takes place, the unit will go into a continuous monitor mode. If, for some reason (eg gas supply failure), the flame is interrupted, the unit will detect the loss of flame and revert to the ignition cycle to try to re-establish the flame. If re-ignition is successful within 7 seconds, the unit goes back into the monitor mode; if not, the unit goes into 'Lock-Out'.
4. If Lock-Out occurs at any time, the unit must be reset before the heater can be used again. To Reset the unit, turn OFF the power supply to the unit for a minimum of 30 seconds. Power may then be restored and ignition tried again.
5. When commissioning a new installation, it may take several attempts to attain ignition due to air in the gas lines. The unit will have to be reset after each unsuccessful attempt as described above with the exception that the rest period need only be 10 seconds as the heater will not be hot. Polarity of power point, or supply must be correct.

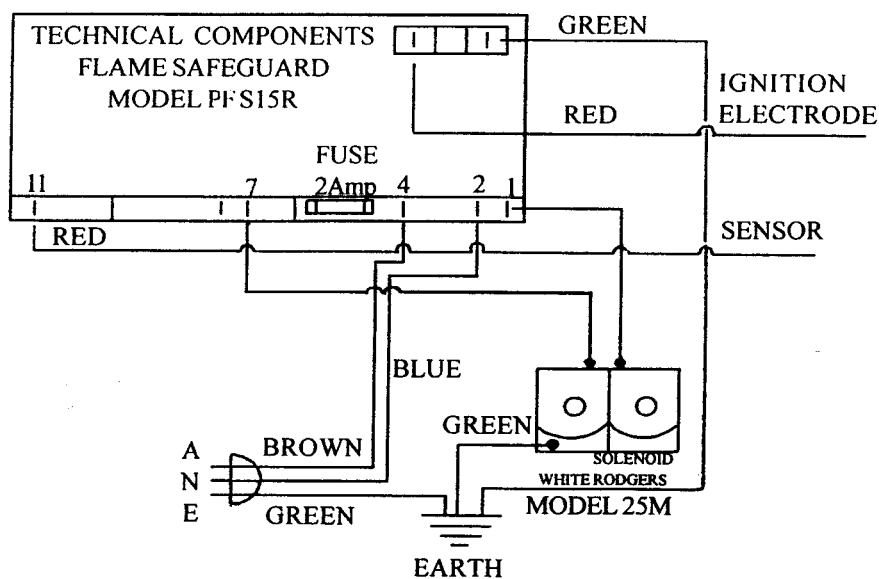

240V/50Hz AC AUST
230V/50Hz AC NZ

WE. SERIES
SUPERAY WIRING
DIAGRAM 1997

INSTALLATION INSTRUCTIONS

WFA Manual Ignition Flexi Ray

The WFA model is a stand-mounted portable LPG appliance incorporating the LPG 16, 24, 40 or 48 model Super Ray

1. MOUNTING THE HEATER

1. The Heater is mounted onto its Mounting Bracket and secured.
2. The Mounting Bracket with Heater attached is then fastened to the Stand with 2 securing nuts and bolts.
3. The top portion of the Stand with the Heater attached can then be elevated to the required height and locked into position.

Extended height to centre line of fixing bolts is 2040 mm.

2. CONNECTING THE GAS

1. Fit the 900mm Hose Assembly with Regulator attached, to the Heater.
2. Place the 45kg LPG Cylinder on the Stand and retain with the safety chain provided.
3. Screw the Regulator into the POL Valve and tighten securely.

3. IGNITION PROCEDURE AND OPERATION CHECK

1. Pull the cord down slowly until a click is heard. Check for ignition while holding cord down.
2. Should the Heater fail to ignite, release cord and repeat the above.
3. After ignition, hold down for a further 20 seconds for the flame failure valve to set.

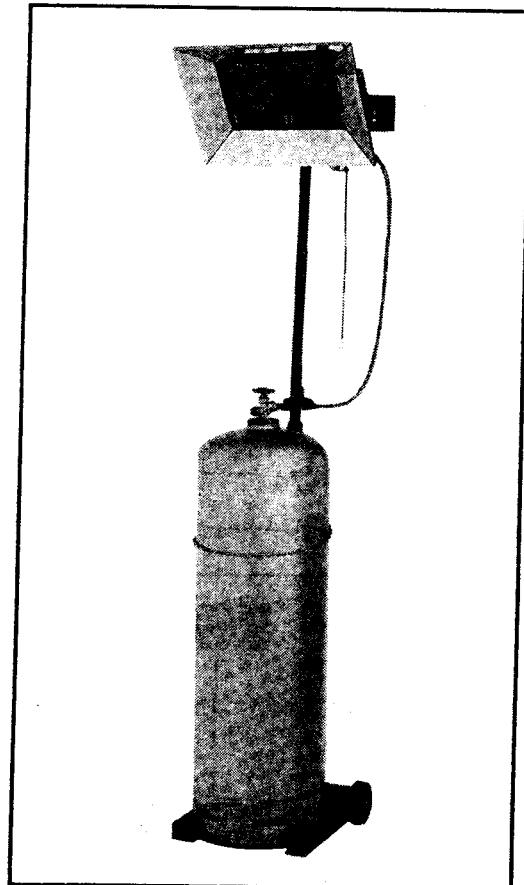
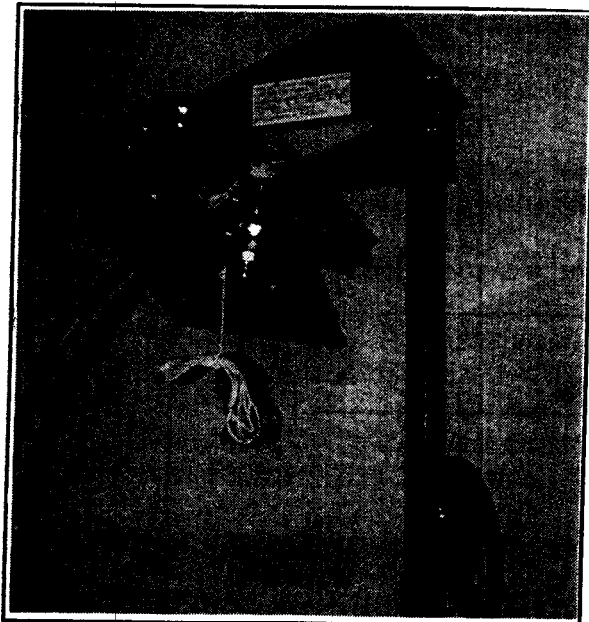

5. IGNITION PROCEDURE AND OPERATION CHECK; (MANUAL ONLY)

1. Pull the cord down slowly until a click is heard, check for ignition while holding cord down.
2. Should the heater fail to ignite, release cord and repeat the above.
3. After ignition, hold down for a further 20 seconds for the flame failure valve to set.

6. INSTALLERS PLEASE NOTE:

When the installation and testing is completed satisfactorily, make sure that the customer knows how to operate the heater. Leave the operating instructions with the customer.

7. SPECIFICATIONS

Description: A multiple burner heater generating infra-red rays which transmit the heat energy and dissipate the heat upon striking a surface.

Inputs: WMA WFA WEA 16=16 MJ
 WMA WFA WEA 24=24 MJ
 WMA WFA WEA 40=40 MJ
 WMA WFA WEA 48=48 MJ

Gas Control WMA: Piezo electric ignition with flame-failure
WFA :

Gas Control WEA: Technical Components Model PFS 15R Electronic Ignition and White Rodgers Model 25m Double Solenoid and Regulator.

Test Point: On the regulator or manifold. See data plate or back page for pressure.

SIZE	APPROX. AREA HEATED M ₂		APPROX. POSITIONING FOR TOTAL HEATING		APPROX. HEIGHT FROM FLOOR	CEILING CLEARANCE
	SPOT	TOTAL	A FACING EACH OTHER	B SIDE BY SIDE	METRES	METRES
16	19	25	8	6.1	3.0	0.9
24	28	37	9.8	7.3	3.4	1.0
40	47	62	15	9	4.5	1.0
48	56	74	17	10	4.9	1.0

Positioning Information

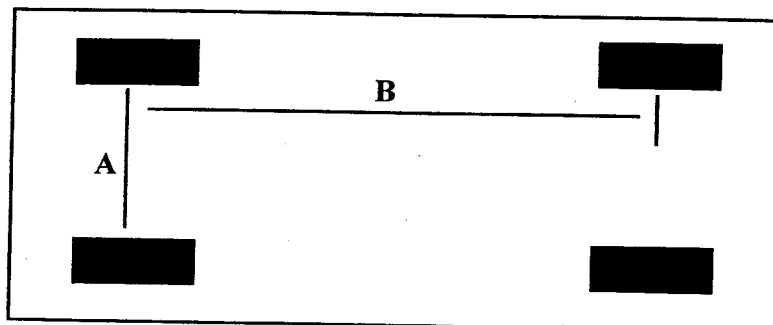

MOUNTING THE HEATER: SUPER RAY.

The wall on which the heater is to be mounted must be secure and capable of supporting the weight of the heater. Place the mounting bracket in position and mark the fixing hole locations on the wall.

This heater shall be firmly and securely attached to the Building or Structure in or on which it is located.

For Brick and Masonry - 8mm Dynabolts (or equivalent).

For Wood/Timber - 38mm x No. 12 screws.

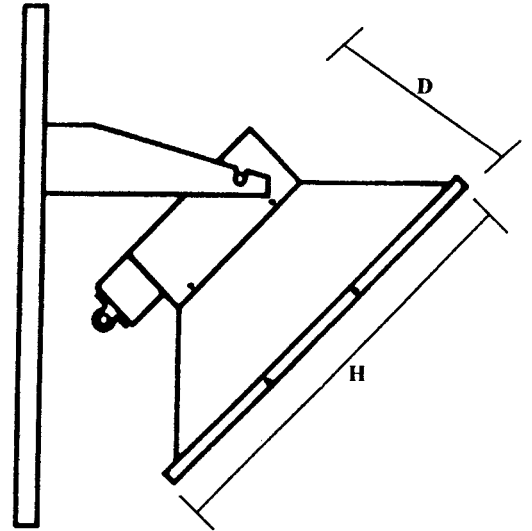
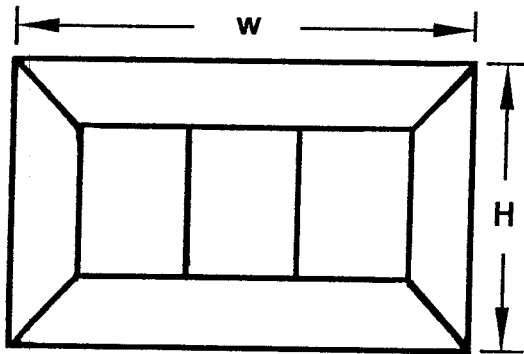

DIMENSIONS IN MILLIMETRES				
MODEL WMA WFA WEA	WIDTH	WEIGHT KG	HEIGHT	DEPTH
16	401	5.6	334	180
24	499	6.5	334	180
40	695	8.4	334	180
48	793	9.3	334	180

The heater can now be hung on the bracket. Slacken off the securing nuts and slide the heater bolts into the 'U' slots, then tighten the nuts.

4. CONNECTING THE GAS:

Note: A manual isolating valve must be fitted.
Connect the unit to a correctly sized gas supply.

The inlet connection sizes are:

NATURAL GAS - All Model sized - 1/2" copper flare union

LPG GAS - All Model sized - 3/8" copper flare union

Tighten all the connections and then turn on the gas supply. Check for any leakage with a solution of soapy water.

Under NO circumstances, should a naked flame be used to test for any gas leakage.

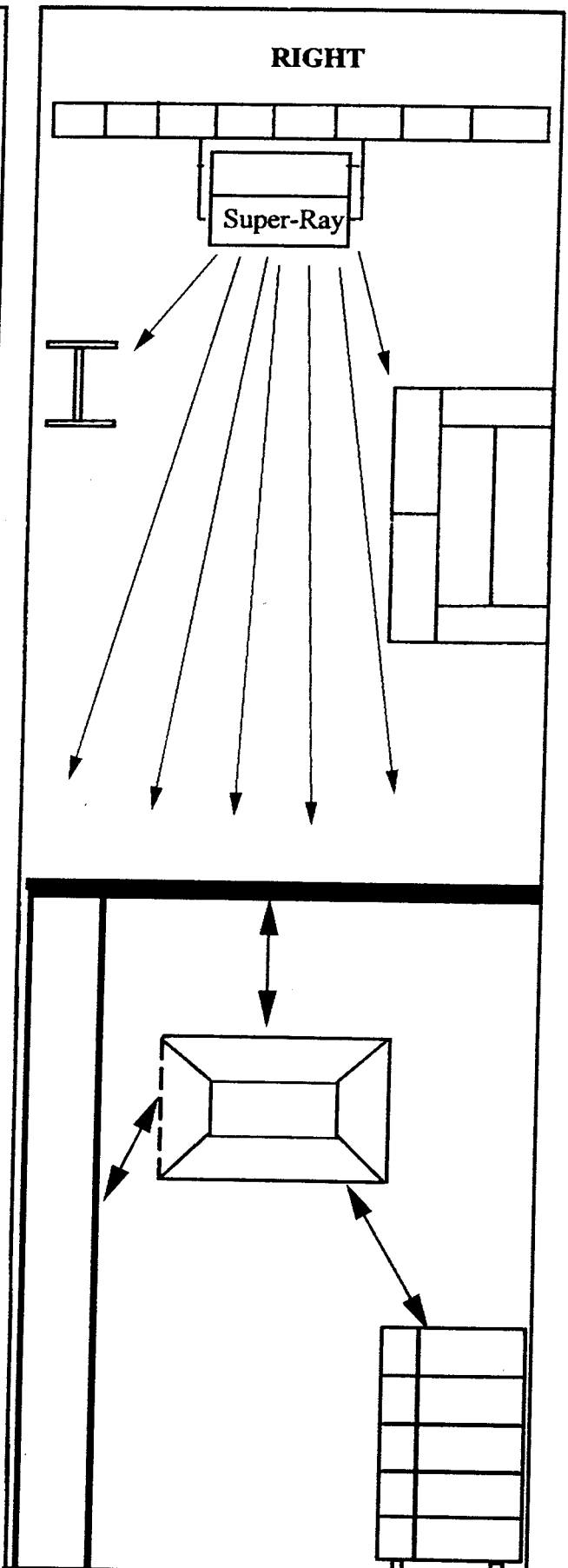
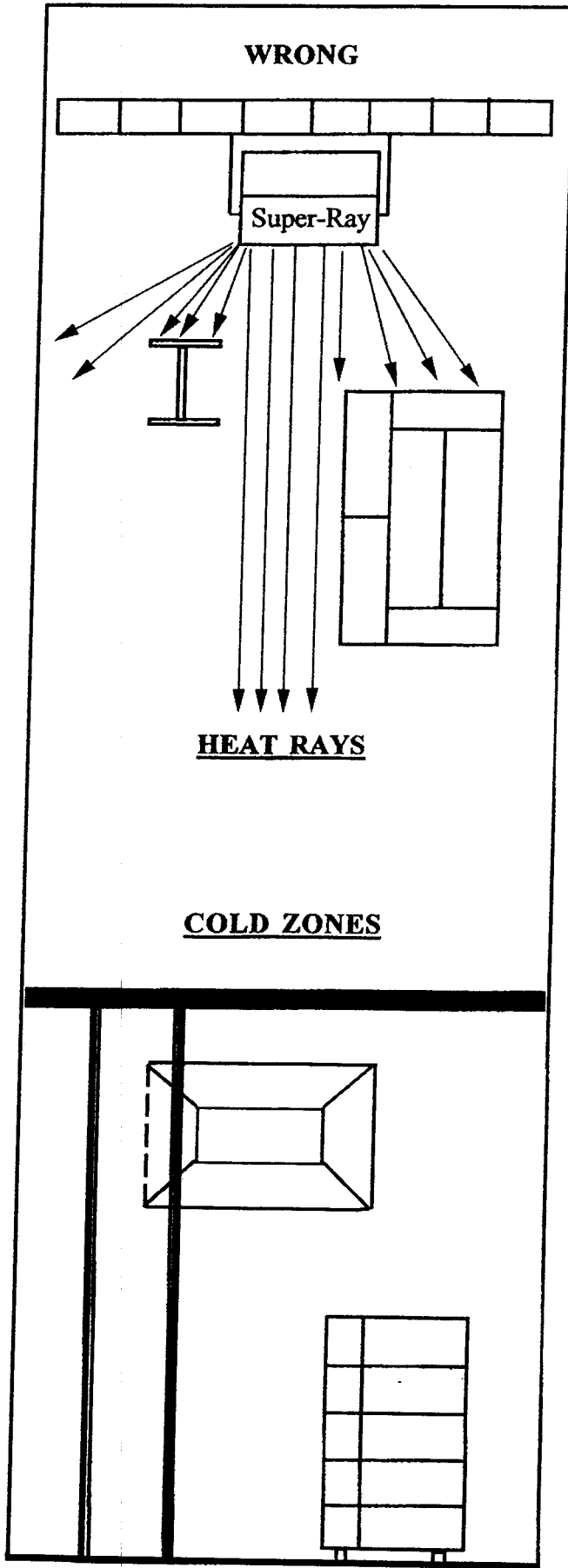

1. This appliance is to be installed only by an authorised person. When unpacking the heater, check that the unit is labelled for the correct gas type and that the unit has not suffered any damage during transit

2. **SELECT A SUITABLE POSITION:**

The appliance is not designed for indoor domestic use.

The chart and the diagrams on page 5 will help to select suitable positions for Super Ray units. The heaters can be used for either 'Spot' or 'Total' heating, depending on the requirements of the application.

Ceiling clearances are important: The heater discharges the products of combustion from the top. Therefore, if the recommended ceiling clearances are not complied with, the ceiling will be discoloured or damaged. (See page 5)

This heater shall not be installed in a position where it could create a fire hazard.

VENTILATION REQUIREMENTS

Ventilation requirement must comply with AG601.

- DO NOT PLACE ARTICLES ON OR AGAINST THE APPLIANCE.
- DO NOT USE OR STORE FLAMMABLE MATERIALS NEAR THIS APPLIANCE
- DO NOT SPRAY AEROSOLS IN THE VICINITY OF THIS APPLIANCE WHILE IT IS IN OPERATION.

Super-Ray units direct their heat via infra-red rays which discharge the heat energy upon striking a surface. They do not pass through solid materials. When installing the units obstructions to the path of the rays must, therefore, be taken into consideration, from both a heating and a safety point of view.

For the most efficient heating and safest working conditions, obstructions in the path of the heat rays should be avoided where possible. Ceiling clearance is also an important factor. Materials stored near the heater must be at a safe distance as the infra-red rays heat solid objects quickly.

INSTALLATION INSTRUCTIONS

- WMA Manual Ignition Super Ray
- WFA Manual Ignition Flexi Ray
- WEA Electronic Ignition Super Ray

AIRA



Infra Red Gas Heating For
Commercial And Industrial Use

**THIS APPLIANCE TO BE INSTALLED
ONLY BY AN AUTHORISED PERSON.
IT IS NOT DESIGNED FOR INDOOR
DOMESTIC USE.**

This appliance shall be installed in accordance with:

- Manufacturer's Installation Instructions
- Local Gas Fitting Regulations
- Municipal Building Codes
- A.G.A. Installation Code for Gas Burning Equipment
- Any other Relevant Statutory Regulations