



Prüfbuch und Gebrauchsanleitung Höhensicherungsgerät nach DIN EN 360/2002

*Instructions for the use and inspection records
fall arrestor
to EN 360/2002*

CANNED ^{FK}

Plant NO. 2621 006

Fall Arrest Boole 30m

!!! PRÜFBUCH IMMER BEIM GERÄT AUFBEWAHREN - USER MANUAL SHOULD BE AVAILABLE TO USERS AT ALL TIMES !!!

- D GB E F I P NL PL RO DK S FIN N
- HU GR



Höhensicherungsgerät nach DIN EN 360/200;
fall arrester EN 360/2002

Fall Arrest Block 30m

Purchase date 09/2013

PLC 40878

Typ / type: H33
 Seriennummer / serial no: 621413 ✓
 Herstellungsdatum /
 date of manufacturing: Dez-12

Plant No. 2621006

Nr./Jahr No./year	Erst- Abnahme				
Position/ item					
Bremseinstellung/ brake adjustment:	184.9 Nm				
Band-/Seildurchmesser/ web/cable diameter:	4,5 mm				
Band-/Seillänge/ web/cable length:	30 m				
Ansprechen der Klinke/ response of paw/s:	ok				
Federeinzug/ spring:	ok				
Karabinerhaken/ snap hook:	IKV34				
Ansprechlänge mit 35 kg/ response length 35 kg:	47 cm				
Aufgangskraft/ catching power:	3,56 kN				
Band-/Seileinzug/ web/cable retraction:	ok				
Sichtkontrolle/ visual inspection:	ok				
Lesbarkeit Typenschild/ readability label:	ok				
Datum der Abnahme/ Date:	11.12.2012				
Grund der Bearbeitung/ purposes:					
Festgestellte Mängel/ observed defects:					

SCANNED 737



Instructions for use

Safety considerations

1. Fall arrestors in accordance with DIN EN 360/2002 represent personal safety equipment serving to protect the user in conjunction with a safety harness DIN EN 361 where falling hazards exist (e.g. on roofs, scaffolding, ladders and in shafts). The device must only be used corresponding to its intended purpose.
2. Failure to comply with the instructions for use will result in a danger to life. (Picture 2) In the event of a fall, the person must not be exposed to a prolonged state of hanging for longer than 20 minutes (danger of shock).
3. Safety harnesses according to EN 361 are permitted for use with the fall arrestor (other harnesses etc. are not permissible). (Picture 1)
4. A device can only protect one person at a time during use. However, it may be used by several individuals one after the other. A rescue plan taking into account all possible rescue scenarios during the work must be drawn up.
5. A suitable fastening point with sufficient load bearing capacity must be selected for the device (e.g. anchorage point corresponding to DIN EN 795; 10 KN). The device is fastened using karabiner hooks corresponding to DIN EN 362 (mountaineering karabiner hooks) or sling rope, the rope being pulled through the handle of the device and closed with a secured karabiner hook. (Picture 3) In case of devices with swivel suspension, the snap hook is connected to the attachment point of the swivel.
6. The device should be positioned as vertically as possible above the head of the person, so as to prevent the person from swinging to and fro in the event of a fall. After fastening the device to the anchorage point, the end of the retractable lanyard (lifeline) must be fastened directly to the harness attachment point (D-ring) by using the small connector. This must be secured by the screwed barrel if the connector is not self-locking. (Picture 4)
7. The safety protection for the person working is established after fastening the fall arrestor to a suitable anchorage point (corresponding to DIN EN 795 or min. 7.5 kN load bearing capacity on existing constructions; BGR 199) and connecting the joining element (hook) to a catching lug of the retaining belt worn (as per DIN EN 361).
8. The legibility of the product labeling must be checked each time before use.
9. A functional test is to be carried out before each use by pulling out the rope all of a sudden or by a weight test of at least 15 kg. The drum brake must catch here. (Picture 5)
10. Fall arrestors must not be used for the safety of persons above bulk materials or similar substances into which they can sink. (Picture 6)
11. A damaged device which has been subject to strain (or if you have doubts concerning the safe state of the device) must be taken out of use immediately. It may only be reused after checking and written approval by an expert.
12. Depending on the strains to which they have been subjected, fall arrestors must be checked by authorized personnel trained by the manufacturer every twelve months. This must be documented in the accompanying test supplied. The effectiveness and durability of the height safety device depends on regular testing.
13. If a thread breaks, the cable is kinked, or the cable/webbing becomes roughened, worn or damaged in any way, the fall arrestor must be returned to the repair workshop so that the damaged component can be replaced. (Picture 7)
14. The Professional Employee Liability Association Regulation BGR 198 (falling) and BGR 199 (rescuing) as well as BGI 870 must be observed.
15. In case of an attachment above the user, the clear height below the user must amount to 2.0m.
16. The IKA R fall arrestor can be used in the temperature range from -30° to +50° Celsius as per EN 360. (Picture 8)
17. The working load limit is 136 kg. (Picture 9)
18. Fall arrestors must be protected against the effects of welding flames and sparks, fire, acids, caustic solutions and similar.
19. No changes or modifications should be made to the fall arrestor. Repairs may be performed by the manufacturer or persons trained and authorised by the manufacturer only. (Picture 10)
20. Repairs may be performed by the manufacturer or persons trained and authorised by the manufacturer only. **Note:** fall arrestors may only be used by persons who have received corresponding training or who have gained expertise in another way. Their health or state of mind must not be impaired in any way (alcohol, drugs, medicines, heart or circulation problems).
21. The service life of the fall arrestor must be determined during the annual test. This is approx. 10 years, depending on the use to which it is subjected.
22. Type HWB / HWPB / HWS / HWPS fall arresting devices equipped with a pipe hook swivel suspension must be mounted to the attachment points in a way to avoid any exposure of the pipe hook swivel suspension to transversal or bending loads. This is of particular importance in case of a fall.

Care and maintenance

1. The cable/webbing lifeline should only be recoiled under tension. On no account should you fully pull out and release the lifeline, as the jolting impact of the small connector on the device can cause the return spring to break. (Picture 11)
2. For devices with a steel cable which are continuously exposed to the weather, we recommend lightly greasing the wire rope with acid-free oil or Vaseline at regular intervals.
3. The retractable belt strap lanyard is made of PES / Dyneema and must only be cleaned with soap suds and never with thinners or similar products.
4. Fall arrestors must be stored in a dry location free of dust and oil, if possible in the packaging supplied.

Attention, very important!

5. Textile elements which have become wet during cleaning or use may only be left to dry naturally, i.e. not in the vicinity of fire or heat sources.

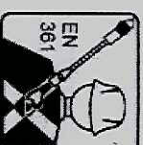

Picture 1



Picture 2

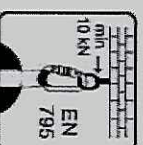

Picture 3



Picture 5

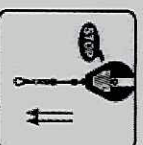

Picture 6



Picture 7

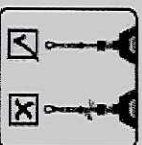

Picture 8

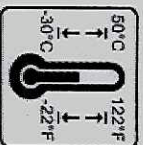

Picture 9

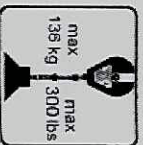

Picture 10



Horizontal use

Note: The fall arrestor has also been successfully tested for horizontal use and a fall over the edge simulated from this. In this case, an edge radius of $r = 0,5\text{mm}$ was used for fall arresting devices with wire rope lanyards and fall arresting devices with a belt strap lanyard. On the basis of this, the fall arrestor is suitable for use over similar edges, such as on rolled steel profiles, wooden beams or a covered, rounded parapet wall.

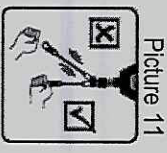

Picture 11

Fall arrestors with wire rope are also suitable for loads over edges such as those of pliable (non-supported) trapezoidal sheeting or pre-cast concrete elements, or from in-situ concrete edges. Despite this test, the following must be observed for all cases during horizontal or sloping use where there is a risk of falling over an edge:

Picture 12



$r \geq 0,5\text{ mm}$

1. If the hazard evaluation performed before commencing work reveals that the fall edge involves a particularly "sharp cutting" and / or "burred" edge (e.g. uncovered parapet walls or sharp concrete edge and if devices with fasteners made from webbing are to be used:
 - corresponding precautions must be taken so that a fall over the edge is precluded, or
 - an edge protection must be mounted before commencing work, or
 - the manufacturer must be contacted.
2. The suspension point of the fall arrestor must not be below the standing area (e.g. platform, flat roof) of the user. (Picture 13)
3. The deflection at the edge (measured between the two flanges of the joints and fastenings) must be at least 90° .
4. The required headroom below the edge is depicted in Picture 15 and 16.
5. In order to prevent a swinging fall, the work area or side movements from the center axis must be restricted to max. 1,50 m. In other cases, no individual anchorage points, but instead e.g. stopping devices of class C (only if approved for joint use) or D as per DIN EN 795 must be used.
6. **Note:** When using the fall arrestor on a stopping device of class C corresponding to DIN EN 795 with a horizontally moving guide, the deflection of the stopping device must also be taken into consideration when ascertaining the required clearance height below the user. The information in the instructions for use must be observed for this.
7. **Note:** In the case of a fall over an edge, there is a risk of injury during the catching process as a result of the falling person hitting building parts or structural parts.
8. Special measures for rescuing must be specified and practiced for the event of a fall over the edge.
9. **Note:** Fall arresting devices identified with Picture 14 are not suited for fall impacts over unprotected edges (e.g. retractable Dyrneema or stainless steel rope lanyards).

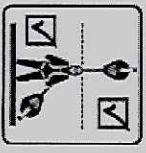

Picture 13



Picture 14

Picture 15 Rectangular fall over edges

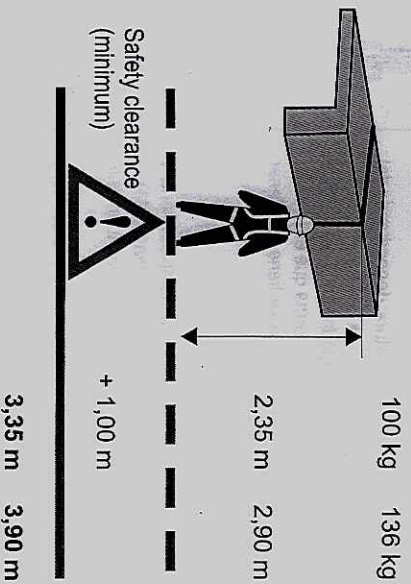

Picture 16 Lateral fall over edges

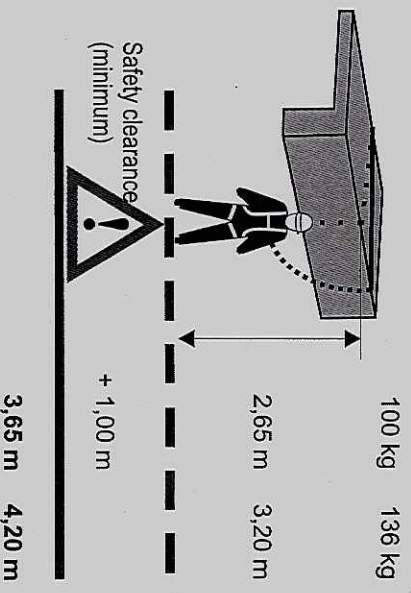



Höhensicherungsgerät nach DIN EN 360/200;
fall arrester EN 360/2002

Fall Arrest Block 30m

Purchase 09/2013

plc 40878

Typ / type: H33
 Seriennummer / serial no: 621413 ✓
 Herstellungsdatum /
 date of manufacturing: Dez-12

Plant No. 2621006

Nr./Jahr No./year	Erst- Abnahme			
Position/ item				
Bremseinstellung/ brake adjustment:	184.9 Nm			
Band-/Seildurchmesser/ web/cable diameter:	4,5 mm			
Band-/Seillänge/ web/cable length:	30 m			
Ansprechen der Klinke/ response of pawls:	ok			
Federeinzug/ spring:	ok			
Karabinerhaken/ snap hook:	IKV34			
Ansprechlänge mit 35 kg/ response length 35 kg:	47 cm			
Aufgangskraft/ catching power:	3,56 kN			
Band-/Seileinzug/ web/cable retraction:	ok			
Sichtkontrolle/ visual inspection:	ok			
Lesbarkeit Typenschild/ readability label:	ok			
Datum der Abnahme/ Date:	11.12.2012			
Grund der Bearbeitung/ purposes:				
Festgestellte Mängel/ observed defects:				

SCANNED 7374