

Instruction manual

Operating & Maintenance

4812311911.pdf

Vibratory rollers CC1200 VI - CC1400 VI

Engine

Kubota D1703 / V2403

Models and PIN

CC1200 VI (Stage IIIA) (26 kW)	10000395xxC008828 -
CC1200 VI (T4f & CS IV) (18.5 kW)	10000446EKC009353 -
CC1300 VI (R96 & CS IV) (36.5 kW)	10000622LPC012656 -
CC1400 VI (R96 & CS IV)(36.5 kW)	10000624xxCXXX



Translation of original instruction

Table of Contents

Introduction	1
The machine	1
Intended use	1
Training	1
Signal symbols and meaning	1
Safety information	1
General	2
CE marking and Declaration of conformity.....	3
Safety - General instructions.....	5
Safety - when operating.....	7
Work driving	7
Driving near edges	8
Safety (Optional).....	9
Edge cutter/compactor	9
Chip spreader.....	10
Special instructions	11
Standard lubricants and other recommended oils and fluids	11
Higher ambient temperatures, above +40°C (104°F).....	11
Lower ambient temperature - Freeze risk	11
Temperatures.....	11
high pressure cleaning	11
Fire fighting	12
Fire extinguisher.....	12
Roll Over Protective Structure (ROPS)	12
Battery handling	13
Jump starting.....	13
Technical specifications	15
Vibrations - Operator station	15
Noise level.....	15
Dimensions, top view (CC1200VI)	16

Dimensions, top view (CC1300VI - CC1400VI)	17
Dimensions, side view (CC1200VI)	18
Dimensions, side view (CC1300VI - CC1400VI)	19
Weights and volumes	20
Working capacity	20
General	23
CO ₂ -emission	23
Tightening torque	24
ROPS - bolts	25
Foldable ROPS - bolts	25
Hydraulic system	26
Slopes	26
Electrical system	26
Machine description	27
Diesel engine	27
Electrical system	27
Propulsion system/Transmission	27
Brake system	27
Steering system	27
ROPS	27
Identification	28
Product and component plates	28
Product identification number on the frame	29
Explanation of 17PIN serial number	29
Machine plate	30
Engine plates	30
Location - decals (CC1200VI)	33
Location - decals (CC1300 VI / CC1400 VI)	35
Location - decals, CALIFORNIA	36
Safety decals	36

Info decals	40
Instruments/Controls	41
Locations - Control panel and controls.....	41
Function description	42
Function description - Alarm	43
Machine alarm.....	44
Functional description - Membrane panel	45
Function description, buttons on Forward/Reverse lever	47
Speed adjustment and vibration frequency (CC1200/C VI - CC1400/C VI with single amplitude)	48
Mechanical speed control	48
Electronic speed control	48
Navigation submenus.....	49
Function description - Display	49
Display explanations	49
Transport mode	50
Submenu - Regeneration (D1803 (Tier 4f, Stage V) / V2403-CR (Tier 4f, Stage V)).....	51
Soot	51
Submenu - Error code list	53
User settings.....	54
"SERVICE MENU"	55
Working mode, Vibration	56
Working mode - Edge cutter	58
Working mode - Chip spreader	59
Asphalt temperature meter (Optional)	60
Operator help when starting.....	61
Operator help Workmode.....	61

Electrical system.....	62
Fuses on machine (CC1200VI)	62
Fuses on machine (CC1300 VI / CC1400 VI)	63
Fuses at battery master disconnect switch	64
Relays on machine.....	65
Operation	67
Before starting	67
Master switch - Switching on.....	67
Driver seat - Adjustment.....	68
Parking brake - Check.....	69
Reserve brake - Control	70
Instruments and lamps - Checking.....	70
Interlock.....	71
Operator position.....	71
Adjusting the Off-set.....	72
Flow divider (Optional)	72
Starting	73
Starting the engine	73
D1703 / V2403-M(R96 & CS IV).....	73
Driving	75
Operating the roller	75
D1703 / V2403-M(R96 & CS IV)	75
Interlock/Emergency stop/Parking brake - Check.....	76
Edge cutting (Optional)	77
Vibration	78
Manual/Automatic vibration.....	78
Braking	79
Normal braking.....	79

Emergency braking	79
Switching off	80
D1703 / V2403-M.....	80
Parking	81
Chocking the drums	81
Battery disconnecter	81
Long-term parking.....	83
Engine	83
Battery.....	83
Air cleaner, exhaust pipe.....	83
Fuel tank	83
Hydraulic reservoir	83
Steering cylinder, hinges, etc.	84
Watering system	84
Hoods, tarpaulin	84
Miscellaneous	85
Lifting	85
Locking the articulation	85
Lifting the roller.....	86
Lifting the roller with a single -point lift (Optional) (CC1200VI only)	87
Unlocking the articulation	88
Towing/Recovering.....	89
Release the brakes	89
Towing the roller.....	91
Short distance towing with switched off engine.....	92
Transport	93
Securing CC1200/C VI for loading.....	94

Securing CC1200/C VI for loading (Side along the trailer)	96
Securing CC1200/C VI for loading (Side across the trailer)	100
Securing CC1300/C VI - CC1400/C VI for loading	102
Foldable ROPS	104
Operating instructions - Summary	105
Preventive maintenance	107
Acceptance and delivery inspection	107
Warranty	107
Maintenance - Lubricants and symbols	109
Maintenance symbols	112
Maintenance - Maintenance schedule	113
Service and maintenance points	113
General	114
Every 10 hours of operation (Daily)	114
After the FIRST 50 hours of operation	115
Every 50 hours of operation (Weekly)	115
Every 250 / 750 / 1250 / 1750 hours of operation	115
Every 500 hours of operation	116
Every 1000 hours of operation	117
Every 1500 hours of operation (only Tier 4f / Stage V (28 kW) / Stage V (37 kW))	117
Every 2000 hours of operation	118
Every 3000 hours of operation	119
Every 12th month (Annually)	120
Every 24th month (Every other year)	120
Service - Checklist	121
Maintenance, 10h	123
Check - Coolant system	124
Diesel engine Check oil level	124

Hydraulic reservoir, Level check - Filling.....	126
Air circulation - Check	126
Fuel tank - Filling.....	127
Water tank - Filling	127
Sprinkler system/Drum Checking - Cleaning.....	128
Sprinkler - Drain / Anti-freeze.....	128
Sprinkler system/Drum Cleaning of sprinkler nozzle	129
Scrapers, fixed Checking - Setting.....	130
Scrapers, spring-action (Optional) Checking - Adjustment	130
Brakes - Check.....	131
Maintenance, first 50h.....	133
Engine oil and oil filter - Change	133
Replacing the hydraulic oil filter	135
Bolted joints Check	136
Maintenance - 50h	137
Air cleaner Check main filter	137
Steering cylinder and steering joint - Lubrication	138
Checking the fuel hoses and hose clamps.....	139
Water separator - Draining (on machines equipped with this).....	140
Maintenance measures - 250 h	141
Battery - Check condition	141
Engine oil and oil filter - Change	142
Air cleaner - Cleaning.....	144
Replacing belts/Checking the belt tension	145

Check - Coolant system	146
Check - Air intake hoses	147
Function of the cooling water system (CC1200/C VI)	148
Check - Coolant system	148
Filling coolant	148
Function of the cooling water system (CC1300/C VI - 1400/C VI)	149
Check - Coolant system	149
Filling coolant	149
Maintenance - 500h	151
Battery	
- Check condition	151
Engine oil and oil filter - Change	152
Drum - oil level	
Inspection - filling	154
Rubber elements and bolted joints	
Check	155
Hydraulic reservoir cap - Check	155
Steering cylinder and steering joint - Lubrication	156
Check - Coolant system	157
Air cleaner	
Check - Replacement of main filter	157
Air filter indicator - Resetting	158
Replacing the fuel filter	159
Replacing the pre-filter	159
D1703 / V2403-M-DI-E3B(R96 & CS IV)/ V2403-M(R96 & CS IV)	
.....	160
D1803-CR (Tier 4f / Stage V) / V2403-CR-E4B (Tier 4f) /	
V2403-CR-E5B (Stage V)	160
Fuel tank - Cleaning	160
Check - Air intake hoses	161
Fuel filter's water separator - Draining	
(on machines equipped with this)	162
Replacing belts/Checking the belt tension	163

Coolers	
Checking - Cleaning.....	164
Maintenance - 1000h	165
Battery	
- Check condition	165
Engine oil and oil filter - Change	166
Drum - oil level	
Inspection - filling	168
Rubber elements and bolted joints	
Check.....	169
Hydraulic reservoir cap - Check	169
Steering cylinder and steering joint - Lubrication	170
Check - Coolant system	171
Air cleaner	
Check - Replacement of main filter	171
Air filter indicator - Resetting	172
Backup filter - Change.....	172
Replacing the hydraulic oil filter	173
Replacing the fuel filter.....	174
Replacing the pre-filter	174
D1703 / V2403-M(R96 & CS IV)	175
Fuel tank - Cleaning	175
Replacing belts/Checking the belt tension	176
Checking - Diesel engine valve clearance	177
Coolers	
Checking - Cleaning.....	177
Check - Air intake hoses	178
Check - Spreader	179
Check - EGR cooler	179

Checking of injector tip.....	179
Replacing the oil separator	179
Maintenance - 2000h	181
Battery	
- Check condition	181
Engine oil and oil filter - Change	182
Rubber elements and bolted joints	
Check	184
Hydraulic reservoir cap - Check	184
Steering cylinder and steering joint - Lubrication	185
Check - Coolant system	186
Air cleaner	
Check - Replacement of main filter	186
Air filter indicator - Resetting	187
Backup filter - Change.....	187
Replacing the hydraulic oil filter	188
Replacing the fuel filter.....	189
Replacing the pre-filter	189
D1703 / V2403-M(R96 & CS IV).....	190
Fuel tank - Cleaning	190
Coolers	
Checking - Cleaning.....	191
Water tank - Draining	192
Water tank - Cleaning	192
Edge cutter (Optional)	
- Lubrication	193
Hydraulic reservoir - fluid change.....	194
Drum - Oil change	195
Checking - Diesel engine valve clearance	195
Replacing belts/Checking the belt tension	196

Steering joint - Check.....	197
Maintenance, 3000h	199
Battery	
- Check condition	199
Engine oil and oil filter - Change	200
Drum - oil level	
Inspection - filling	202
Rubber elements and bolted joints	
Check	203
Hydraulic reservoir cap - Check	203
Steering cylinder and steering joint - Lubrication	204
Check - Coolant system	205
Air cleaner	
Check - Replacement of main filter	205
Air filter indicator - Resetting	206
Backup filter - Change.....	206
Replacing the hydraulic oil filter	207
Replacing the fuel filter.....	208
Replacing the pre-filter	208
D1703 / V2403-M(R96 & CS IV)	209
Fuel tank - Cleaning	209
Check - Air intake hoses	210
Coolers	
Checking - Cleaning.....	211
Water tank - Draining	212
Water tank - Cleaning	212
Checking - Diesel engine valve clearance	212
Hydraulic reservoir - fluid change.....	213
Draining of water separator.....	214
Replacing belts/Checking the belt tension	215

Checking the injection pump (D1703 and V2403-M(R96 & CS IV only).....	216
Steering joint - Check.....	216
Maintenance, every 12th month (Annually)	217
Air cleaner	
Check - Replacement of main filter	217
Air filter indicator - Resetting	217
Backup filter - Change.....	217
Maintenance, every 24th month (Every other year)	219
Check - Coolant system	219
Check - Air intake hoses	220

Introduction

The machine

Dynapac CC1200 VI - CC1400 VI are four vibratory tandem rollers in the 2 to 4-tonnes class with 1100 - 1400 mm wide drums. They feature power drive, brakes, and vibration on both drums.

Intended use

The rollers are mainly intended for compaction of thin layers and soft asphalt masses for minor construction work, such as small streets, pavements, cycle paths and garage drives. It has sufficient capacity to follow a small asphalt paver.

Training

The purpose of operator training is to impart the operator the knowledge and skills necessary for proper operation and routine maintenance of the roller according to this manual.

Note to trainer: Further information on operator training can be found in ISO 7130.

Signal symbols and meaning



WARNING ! Indicates potential hazardous situation/procedure which, if not avoided, could result in death or serious injury.



CAUTION ! Indicates potential hazardous situation/procedure which, if not avoided, could result in minor or moderate injury, damage to the machine or property.

Safety information



It is recommended to at least train operators in handling and daily maintenance of the machine in accordance with the instruction manual. Passengers are not allowed on the machine, and you must sit in the seat when operating the machine.



The safety manual supplied with the machine must be read by all roller operators. Always follow the safety instructions. Do not remove the manual from the machine.



We recommend that the operator reads the safety instructions in this manual carefully. Always follow the safety instructions. Ensure that this manual is always easily accessible.



Read the entire manual before starting the machine and before carrying out any maintenance.



Replace immediately the instruction manuals if lost, damaged or unreadable.



Ensure good ventilation (extraction of air by fan) where the engine is run indoors.

CALIFORNIA

Proposition 65

Decal and location of decal shown in section Machine description.

 **WARNING:** Breathing diesel engine exhaust exposes you to chemicals known to the State of California to cause cancer and birth defects or other reproductive harm.

- Always start and operate the engine in a well-ventilated area.
- If in an enclosed area, vent the exhaust to the outside.
- Do not modify or tamper with the exhaust system.
- Do not idle the engine except as necessary.

For more information go to www.P65warnings.ca.gov/diesel.

General

This manual contains instructions for machine operation and maintenance.

The machine must be correctly maintained for maximal performance.

The machine should be kept clean so that any leakages, loose bolts and loose connections are discovered at as early a point in time as possible.

Do not spray with high-pressure cleaner directly onto gaskets and bearing spacings in steering hitch and drum, and electronics.

Inspect the machine every day, before starting. Inspect the entire machine so that any leakages or other faults are detected.

Check the ground under the machine. Leakages are more easily detected on the ground than on the machine itself.



THINK ENVIRONMENT ! Do not release oil, fuel and other environmentally hazardous substances into the environment. Always send used filters, drain oil and fuel remnants to environmentally correct disposal.

This manual contains instructions for periodic maintenance, where maintenance after every 10 and 50 hours of operation can be performed by the machine operator. Other maintenance intervals must be carried out by accredited (Dynamac) service personnel.



Additional instructions for the engine can be found in the manufacturer's engine manual.

Specific maintenance and checks on diesel engines must be performed by engine supplier authorized personnel.

CE marking and Declaration of conformity

(Applies to machines marketed in EU/EEC)

This machine is CE marked. This shows that on delivery it complies with the basic health and safety directives applicable for the machine in accordance with machinery directive 2006/42/EC and that it also complies with other regulations and directives applicable for this machine.

A "Declaration of conformity" is supplied with this machine, which specifies the applicable regulations and directives with supplements, as well as the harmonized standards and other regulations that are applied and according to the regulations must be declared in writing.

Safety - General instructions

(Also read the safety manual)



- The operator must be familiar with the contents of the OPERATION section before starting the roller.
- Ensure that all instructions in the MAINTENANCE section are followed.
- Only the operator is allowed to be on the roller. Remain seated at all times when operating the roller.
- Never use the roller if it is in need of adjustment or repair.
- Only ascend and descend the roller when it is stationary. Use the intended footsteps, grips and rails. Always use the three-point grip (both feet and one hand, or one foot and both hands) when ascending or descending the machine. Never jump down from the machine.
- Dynapac always recommends mounted ROPS (Roll Over Protective Structure), or a ROPS-approved cab and seat belt usage.
- Drive slowly in sharp bends.
- Avoid driving across slopes. Drive straight up or straight down the slope.
- Never operate with the drum outside the edge, the substrate might not have full bearing strength or the edge is close to a slope. Avoid operating close to edges and ditches and the like as well as on poor ground conditions that jeopardizes the bearing strength and capacity to support the roller.
- Make sure that there are no obstacles in the direction of travel, on the ground, in front of or behind the roller, or overhead.
- Drive particularly carefully on uneven ground.
- Keep the roller clean. Clean any dirt or grease that accumulates on the footsteps or operator platform to avoid slipping risk. Keep all signs and decals clean and legible.
- Safety measures before refueling:
 - Stop the engine
 - Do not smoke.
 - No naked flames in the vicinity of the roller.
 - Earth the filling equipment nozzle by keeping it in contact to the tank opening to avoid sparks.
- Before repairs or service:
 - Chock the drums/wheels.
 - Lock the articulation if necessary.
 - Place blocks under overhanging equipment, such as strike-off blade, edge cutter/compactor and chip spreader.

- **Hearing protection is recommended if the noise level exceeds 80 dB(A). The noise level can vary depending on the equipment on the machine and the surface the machine is being used on.**
- **Modifications to the roller, including the use of any attachment/equipment, not approved by Dynapac that might compromise safety (including visibility) are not allowed. Any modifications are only to be made after written approval has been given by Dynapac.**
- **Avoid using the roller before the hydraulic fluid has reached its normal working temperature. Braking distances can be longer than normal when the fluid is cold.**
- **For your own protection always wear:**
 - working boots with steel toecaps
 - ear protectors
 - reflecting clothing/high visibility jacket**Also wear:**
 - helmet if no cab or FOPS, or if required by worksite management
 - working gloves if no cab and for work outside operator's platform.
- **If the machine seems to be responding abnormally during travel, stop and check it.**

Safety - when operating



Prevent persons from entering or remaining in the risk zone, i.e. a distance of at least 7 m (23 ft) in all directions from operating machines. The operator may allow a person to remain in the risk zone, however he/she must be attentive and operate the machine only when the person is fully visible or has given a clear indication of where he or she is.



Avoid driving across a slope. Drive straight up and down sloping ground.

Work driving



Dynapac always recommends mounted ROPS (Roll Over Protective Structure) and seat belt usage.

On machines with foldable ROPS, make sure that the ROPS is correctly mounted in the upright position during all operation.

Avoid operating close to edges and ditches and the like as well as on poor ground conditions that jeopardizes the bearing strength and capacity to support the roller. Pay attention to potential obstacles above the machine, such as overhead cables and the branches of trees etc.

Pay particular attention to the stability of the substrate when compacting close to edges and holes. Do not compact with a large overlap from the previous track in order to maintain roller stability. Consider other compaction methods such as remote-control or a walk-behind roller close to steep slopes or where the bearing strength of the substrate is unknown.

Driving near edges



Never operate with the drum outside the edge, the substrate might not have full bearing strength or the edge is close to a slope.



Keep in mind that the machine's center of gravity moves outwards when steering. For example, the center of gravity moves to the right when you steer to the left.

Safety (Optional)

Edge cutter/compactor

 *The operator must make sure that nobody is in the area of operation while the machine is in use.*

 *The edge cutter consists of rotating components and there is a risk of being crushed.*

 The tool must be returned to the transport position (raised position) (1) every time it has been used.

 *If the edge cutter and its parts are dismantled, make sure that it is set in a relieved position and resting on the ground.*

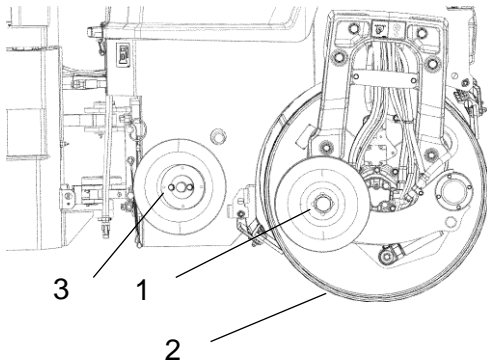

Fig. Edge cutter/compactor (CC1200/C VI)
1. Transport position
2. Operating position
3. Holder for cutter/compactor wheel.

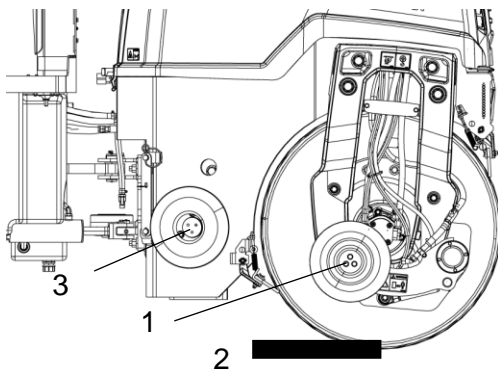

Fig. Edge cutter/compactor (CC1300/C VI - CC1400/C VI)
1. Transport position
2. Operating position
3. Holder for cutter/compactor wheel.

Chip spreader



The machine must not be lifted or transported on another vehicle with chips in the chip spreader. The weight for the chip spreader is specified on the unit rating plate. This weight is not included in the machine weight specified on the lifting plate.



The operator must make sure that nobody is in the area of operation while the machine is in use.



The machine must NOT be lifted from a single-point lift if the chip spreader is fitted. (CC1200 VI only)



Risk of crushing and pinch injuries. The chip spreader has rotating parts.



The chip spreader must be reset in transport mode after it has been used.



Fitting the chip spreader changes the total length of the machine.

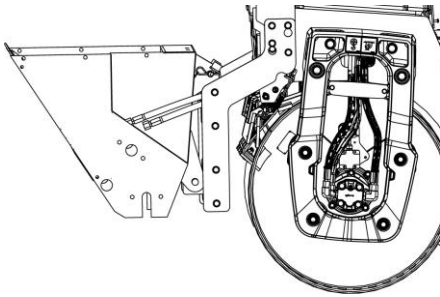

Fig. Chip spreader (CC1200 VI)

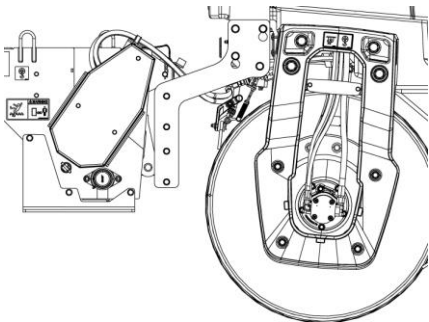

Fig. Chip spreader (CC1300 VI - CC1400 VI)

Special instructions

Standard lubricants and other recommended oils and fluids

Before leaving the factory, the systems and components are filled with the oils and fluids specified in the lubricant specification. These are suitable for ambient temperatures in the range -15°C to +40°C (5°F - 105°F).



The maximum ambient temperature for biological hydraulic fluid is +35°C (95°F).

Higher ambient temperatures, above +40°C (104°F)

For operation of the machine at higher ambient temperatures, however maximum +50°C (122°F), the following recommendations apply:

The diesel engine can be run at this temperature using normal oil. However, the following fluids must be used for other components:

Hydraulic system - mineral oil Shell Tellus S2V100 or similar.

Lower ambient temperature - Freeze risk

Make sure that the watering system is empty/drained of water (sprinkler, hoses, tank/s) or that anti-freeze has been added, to prevent the system freezing.

Close the ball valve and draw up the anti-freeze liquid through the filter. See the chapter dealing with Sprinkler system.

Temperatures

The temperature limits apply to standard versions of rollers.

Rollers equipped with additional equipment, such as noise suppression, may need to be more carefully monitored in the higher temperature ranges.

high pressure cleaning

Do not spray water directly onto electrical components or the instrument panels.

Place a plastic bag over the fuel filler cap and secure with a rubber band. This is to avoid high pressure water entering the vent hole in the filler cap. This could cause malfunctions, such as the blocking of filters.

Do not spray with high-pressure cleaner directly onto gaskets and bearing spacings in steering hitch and drum, and electronics.



Never aim the water jet directly at the fuel tank cap, or into exhaust pipe. This is particularly important when using a high-pressure cleaner.

Fire fighting

If the machine catches fire, use an ABC-class powder fire extinguisher.

A BE-class carbon dioxide fire extinguisher can also be used.

Fire extinguisher

A fire extinguisher can be ordered as an option. Though, different standards are used around the world.

If not using the original fire extinguisher, place your extinguisher as in the picture. A 4 kg extinguisher is recommended.

Mount it appropriately and make sure it does not create any hazards.

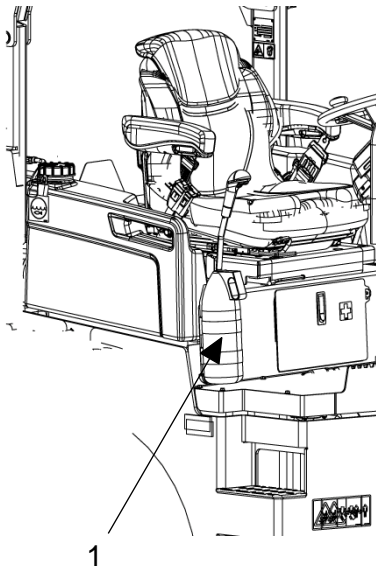

Fig. Plarform
1. Fire extinguisher

Roll Over Protective Structure (ROPS)



Never carry out any welding or drilling in the Roll Over Protective Structure (ROPS).



Never repair a damaged ROPS structure, it must be replaced with a new one.

Battery handling

 **When removing batteries, always disconnect the negative cable first.**

 **When fitting batteries, always connect the positive cable first.**

 Dispose of old batteries in an environmentally friendly way. Batteries contain toxic lead.

 Do not use a quick-charger for charging the battery. This may shorten battery life.

Jump starting

 **Do not connect the negative cable to the negative terminal on the dead battery. A spark can ignite the oxy-hydrogen gas formed around the battery.**

 **Check that the battery used for jump starting has the same voltage as the dead battery.**

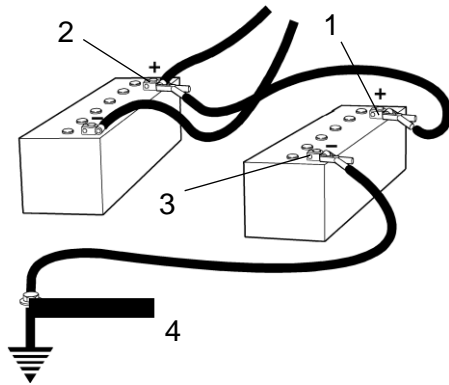

Fig. Jump starting

Turn the ignition and all power consuming equipment off. Switch off the engine on the machine which is providing jump start power.

First connect the jump start battery's positive terminal (1) to the flat battery's positive terminal (2). Then connect the jump start battery's negative terminal (3) to, for example, a bolt (4) or the lifting eye on the machine with the flat battery.

Start the engine on the power providing machine. Let it run for a while. Now try to start the other machine. Disconnect the cables in the reverse order.

Technical specifications

Vibrations - Operator station (ISO 2631)

The vibration levels are measured in accordance with the operational cycle described in EU directive 2000/14/EC on machines equipped for the EU market, with vibration switched on, on soft polymer material and with the operator's seat in the transport position.

Measured whole-body vibrations are below the action value of 0.5 m/s² as specified in Directive 2002/44/EC. (Limit is 1.15 m/s²)

Measured hand/arm vibrations also were below the action level of 2.5 m/s² specified in the same directive. (Limit is 5 m/s²)

Noise level

The noise level is measured in accordance with the operational cycle described in EU directive 2000/14/EC on machines equipped for the EU market, with the vibration switched on, on soft polymer material and with the operator's seat in the transport position.

Guaranteed sound power level, L_{wA}	106	dB (A)
Sound pressure level at the operator's ear (platform), L_{pA}	80 ±3	dB (A)

During operation the above values may differ because of the actual operational conditions.

Dimensions, top view (CC1200VI)

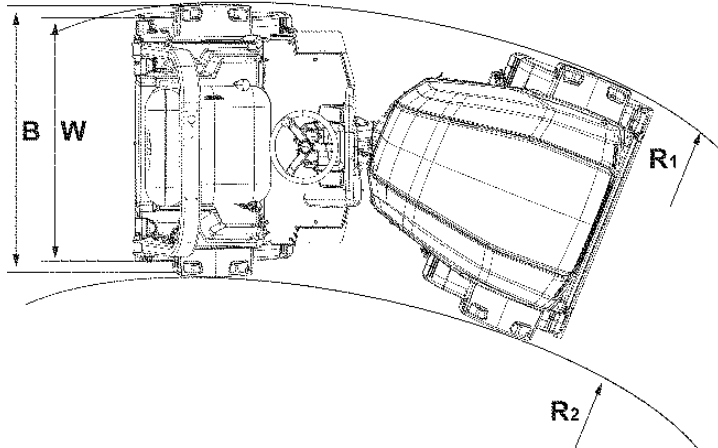

	Dimensions	mm	in
B	Machine width		
	CC1200 VI	1340	53
B (without ROPS)	Machine width		
	CC1200 VI	1340	53
R ₁	Turning radius, outer		
	CC1200 VI	3770	148
R ₂	Turning radius, inner		
	CC1200 VI	2570	101
W	Drum width		
	CC1200 VI	1200	47

Dimensions, top view (CC1300VI - CC1400VI)

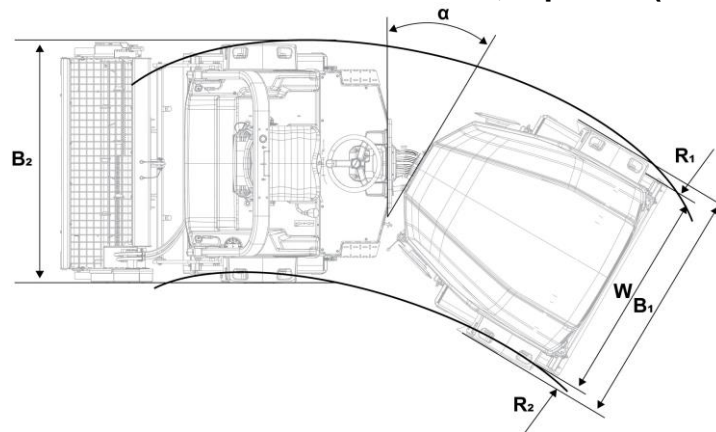

	Dimensions	mm	in
B	Machine width		
	CC1300 VI	1425	56
	CC1400 VI	1505	59
B (without ROPS)	Machine width		
	CC1300 VI	1510	59.4
	CC1400 VI	1510	59.4
B (with double edge cutter)	Machine width		
	CC1300 VI	1425	56
	CC1400 VI	1505	59
R ₁	Turning radius, outer		
	CC1300 VI	4330	170
	CC1400 VI	4370	172
R ₂	Turning radius, inner		
	CC1300 VI	3030	119
	CC1400 VI	2990	118
W	Drum width		
	CC1300 VI	1300	51
	CC1400 VI	1380	54
α	Steering angle		
	CC1300 VI	±41°	
	CC1400 VI	±43°	

Dimensions, side view (CC1200VI)

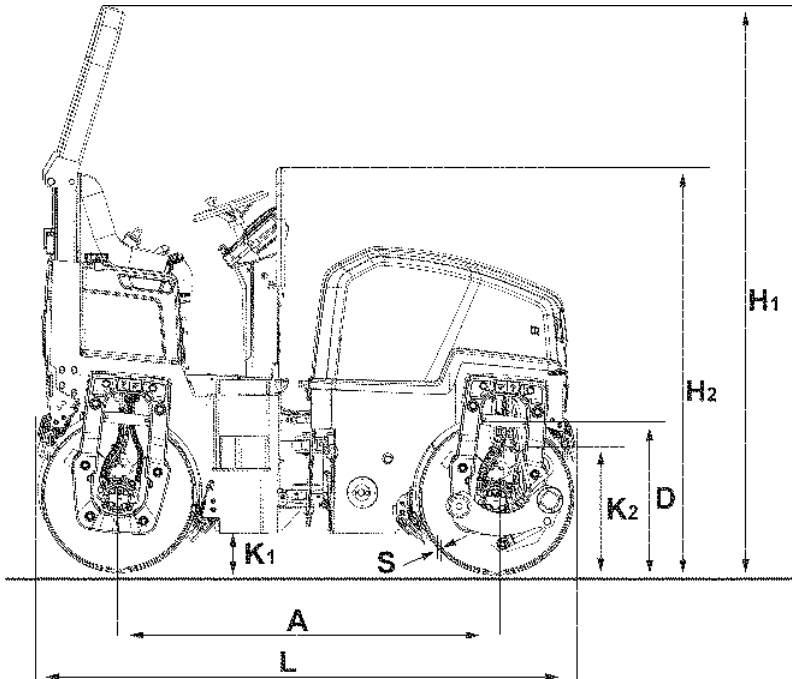

	Dimensions	mm	in
A	Wheel base	1700	67
D	Diameter, drum	700	27
H ₁	Height, with ROPS	2542	100
H ₂	Height, without ROPS	1744	68.5
K ₁		180	7
K ₂		550	22
L	Length	2400	94
	Length, with chip spreader	3220	127
S	Thickness, drum amplitude, Nominal		
	CC1200 VI	13	0.51

Dimensions, side view (CC1300VI - CC1400VI)

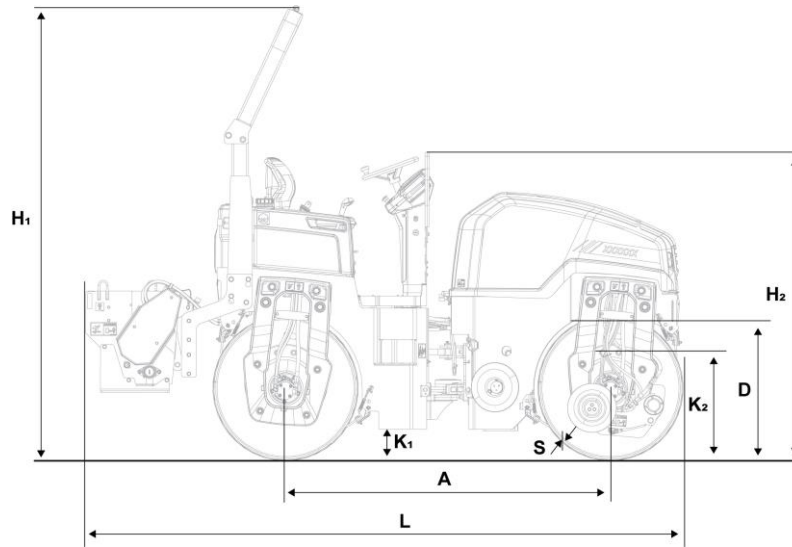

	Dimensions	mm	in
A	Wheel base	1970	77
D	Diameter, drum		
	CC1300 VI	880	34.6
	CC1400 VI	882	34.7
H ₁	Height, with ROPS	2740	108
H ₂	Height, without ROPS	2025	80
H	Height, with Canopy	2855	112
K ₁	Ground clearance	190	7.5
K ₂	Curb clearance	690	27
L	Length	2850	112
	Length, with chip spreader	3625	143
S	Thickness, drum amplitude, Nominal		
	CC1300 VI	16	0.6
	CC1400 VI	17	0.67

Weights and volumes
Fluid volumes

CC1200 VI		
Fuel tank	46 liters	48.6 qts
Water tank	205 liters	216.6 qts
CC1300 VI - CC1400 VI		
Fuel tank	60 liters	63.4 qts
Water tank	298 liters	315 qts

Weights

Weight CECE, Standard equipped roller (including ROPS)

CC1200 VI	2600 kg	5.735 lbs
CC1300 VI	3900 kg	8,598 lbs
CC1400 VI	4300 kg	9,480 lbs

Working capacity
Propulsion

Speed range				
CC1200 VI	0 - 10	km/h	0 - 6.2	mph
CC1300 VI - CC1400 VI	0 - 9.2	km/h	0 - 5.7	mph
Climbing capacity (theoretical)				
CC1200 VI	up to 42*	%		
CC1300 VI	up to 42*	%		
CC1400 VI	up to 37*	%		

*) depending on model, diesel engine, other equipment and operating conditions.

Compaction data (CC1200 VI)

Static linear load (front/rear)

CC1200 VI	10.3/11.4 kg/cm	57.7/63.8 pli
Amplitude	0.5 mm	0.02 in
Vibration frequency		
D1703	66/61 Hz	3960/3660 vpm
Centrifugal force		

CC1200 VI		
- D1703	34/29 kN	7644/6520 lb

Compaction data (CC1300 VI - CC1400 VI)

Static linear load (front/rear)

CC1300 VI	14.3/15.7 kg/cm	80/88 pli
CC1400 VI	15.1/16.1 kg/cm	85/90 pli

Amplitude

- Single	0.5 mm	0.0197 in.
- Double (High/Low)	0.2/0.5 mm	0.0079/0.0197 in.

Vibration frequency

- Single amplitude	54/49 Hz	3.240/2.940 vpm
- Dual amplitudes	61/54 Hz	3.660/3.240 vpm

Centrifugal force

CC1300 VI (Single amplitude)

- V2403-M	38/31 kN	8.543/6.969 lb
-----------	----------	----------------

CC1300 VI (Dual amplitudes)

- V2403-M	38/21 kN	8.543/4.721 lb
-----------	----------	----------------

CC1400 VI (Single amplitude)

- V2403-M	43/35 kN	9.667/7.868 lb
-----------	----------	----------------

CC1400 VI (Dual amplitudes)

- V2403-M	43/22 kN	9.667/4.946 lb
-----------	----------	----------------

General

Engine

Manufacturer/Model	Effect (SAE J1995)	Rpm
Kubota D1703-M-IDI E3B (Stage IIIA)	26.1 kW (35 hp)	2800 rpm
Kubota D1703-M-DI-E4B (Tier 4f, CS IV)	18.5 kW (25 hp)	2200 rpm
Kubota V2403-M-DI-E3B (R96 & CS IV)	36.5 kW (48 hp)	2600 rpm

--	--	--

--	--	--

CO₂-emission

CO₂-emissions measured according to applicable test cycle in Regulation (EU) 2016/1628.

Manufacturer/Model	Test-cycle	CO ₂ -emission (g/kWh)
Kubota D1703-M-DI-E4B (18.5 kW)	T4f & CS IV	NRSC 938.3
Kubota V2403-M-DI-E3B (36.5 kW)	R96 & CS IV	NRSC

NRTC: Non-road transient test cycles
NRSC: Non-road steady-state test cycles

Electrical system

Battery	12V 74Ah
Alternator	12V 60A
Fuses	See the Electrical system section - fuses

Tightening torque

Tightening torque in Nm for oiled or dry bolts tightened with a torque wrench.

Metric coarse screw thread, bright galvanized (fzb):

STRENGTH CLASS:

M - thread	8.8, Oiled	8.8, Dry	10.9, Oiled	10.9, Dry	12.9, Oiled	12.9, Dry
M6	8,4	9,4	12	13,4	14,6	16,3
M8	21	23	28	32	34	38
M10	40	45	56	62	68	76
M12	70	78	98	110	117	131
M14	110	123	156	174	187	208
M16	169	190	240	270	290	320
M20	330	370	470	520	560	620
M22	446	497	626	699	752	839
M24	570	640	800	900	960	1080
M30	1130	1260	1580	1770	1900	2100

Metric coarse thread, zinc-treated (Dacromet/GEOMET):

STRENGTH CLASS:

M - thread	10.9, Oiled	10.9, Dry	12.9, Oiled	12.9, Dry
M6	12,0	15,0	14,6	18,3
M8	28	36	34	43
M10	56	70	68	86
M12	98	124	117	147
M14	156	196	187	234
M16	240	304	290	360
M20	470	585	560	698
M22	626	786	752	944
M24	800	1010	960	1215
M30	1580	1990	1900	2360



ROPS-bolts which are to be torque tightened must be dry.

ROPS - bolts

Bolt dimensions :	M16 (PN 4700902889)
Strength class :	
- CC1200/C VI	8.8
- CC1300/C VI - CC1400/C VI	10.9
Tightening torque :	190 Nm (Dacromet treated)

Foldable ROPS - bolts

Bolt dimensions :	M20 (PN 0211110375)
Strength class :	
- CC1200/C VI	8.8
- CC1300/C VI - CC1400/C VI	10.9
Tightening torque :	190 Nm (Dacromet treated)

Always replace a lost bolt with an original bolt.

Hydraulic system

Opening pressure (Absolute pressure)	MPa	
	CC1200 VI	CC1300 VI - CC1400 VI
Drive system	35.0	35.0
Supply system	2.0	2.0
Vibration system	21.0	22.8
Control systems	18.0	18.0
Brake release	1.2	1.8



Max 20° or 36%

Slopes

The recommended max slope angle is for a machine that runs straight on hard, flat surface.

Unstable ground, vibration on, speed and steering the machine can all cause the machine to topple at smaller angles than specified here.

Electrical system

Machines are EMC tested in accordance with EN 13309:2000 'Construction machinery'

Machine description

Diesel engine

The machine is equipped with a water-cooled, in-line three or four cylinder, four-stroke diesel engine.

Electrical system

The machine has the following control units (ECU, Electronic Control Unit) and electronic units.

- Main ECU (for the machine)

Propulsion system/Transmission

The propulsion system is a hydrostatic system with a hydraulic pump supplying two motors connected in parallel.

The motors drive the front and rear drums.

The speed of the machine is proportional to the deflection/angle of the control lever from neutral.

Brake system

The brake system consists of a service brake, secondary brake and parking brake.

The service brake is hydrostatic and is activated by moving the control lever to neutral.

Secondary/Parking brake

The secondary and parking brake system consists of sprung multiple disc brakes in the motors. The brakes are released with hydraulic pressure and are operated with a switch on the instrument panel.

Steering system

The steering system is a hydrostatic system.

The control valve on the steering column distributes the flow to the control cylinder, which actuates the articulation.

The steering angle is proportional to the deflection of the steering wheel.

ROPS

ROPS is the abbreviation for "Roll Over Protective Structure".

If any part of the ROPS structure's protective construction displays plastic deformation or cracks, the

ROPS structure must be replaced immediately.

Never perform any modifications on the ROPS structure without first having discussed the modification with Dynapac's production unit. Dynapac determines whether the modification could result in the approval according to the ROPS standards becoming invalid.

Identification

Product and component plates

CC1200 VI

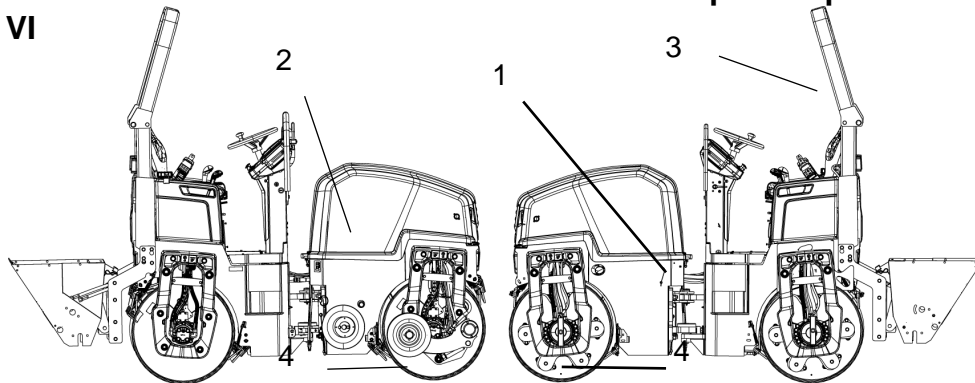

CC1300 VI - CC1400 VI

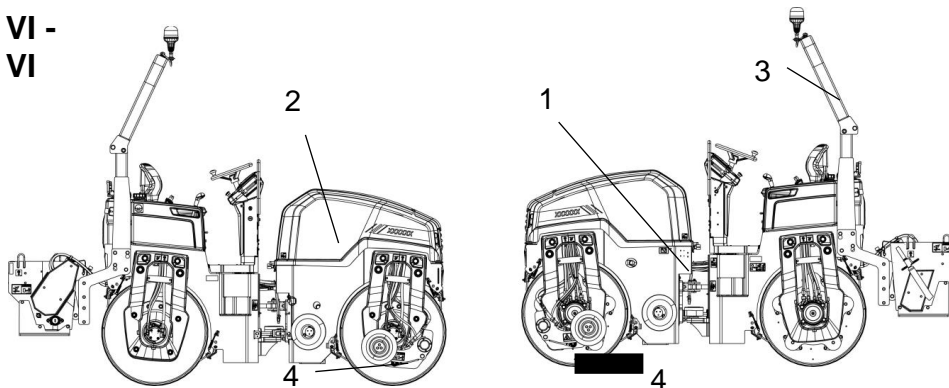

1. Product plate - Product Identification Number (PIN), model/type designation
2. Engine plate - Type description, product and serial numbers
3. ROPS plate - Certification, product and serial numbers
4. Component plate, drum - Product and serial numbers

Product identification number on the frame

The machine PIN (product identification number) (1) is punched on the right side of the front frame.

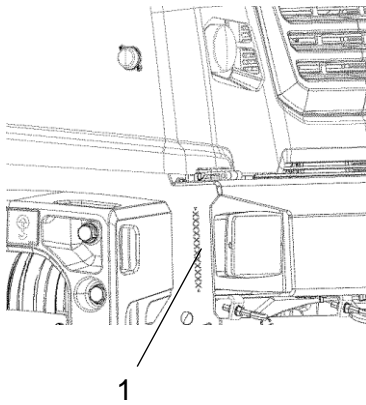

Fig. PIN Front frame
1. Serial number

Explanation of 17PIN serial number

100	00123	V	x	A	123456
A	B	C	F		

A= Manufacturer

B= Family/Model

C= Check letter

F= Serial number

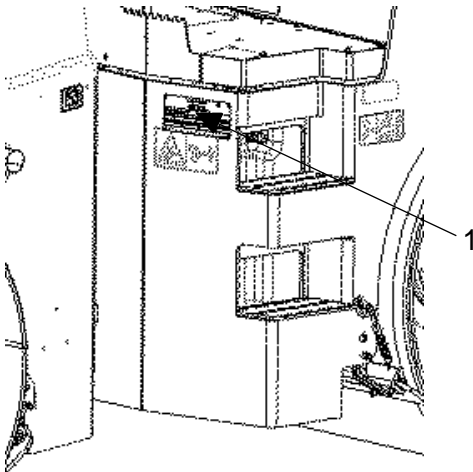

Fig. Operator platform
1. Machine plate
Machine

plate

The machine type plate (1) is affixed on the rear left edge of the frame.

The plate includes:

- name and address of the manufacturer (2)
- type of machine (3)
- PIN-product identification number (serial number) (4)
- maximum weight (5)
- service weight (6)
- engine power (7)
- year of manufacture (8)

If the machine is delivered outside of the EU, the plate may not have a CE marking and the year of manufacture.

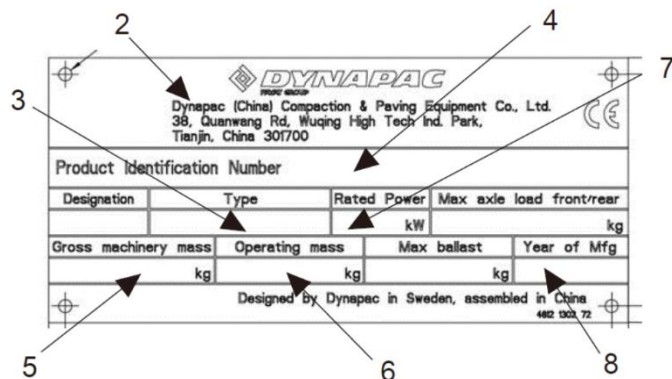

Please state the machine's PIN (serial number) when ordering parts.

Engine plates

The engine's type plate (1) is located on top of the cylinder head cover.

The plate specifies the type of engine, its serial number and the engine specification.

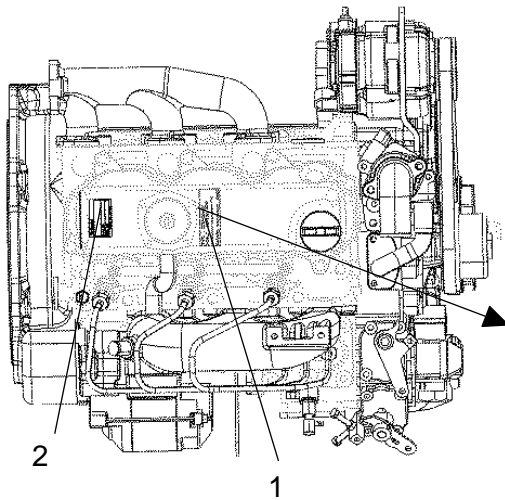

Please specify the engine serial number when ordering spares. Refer also to the engine manual.

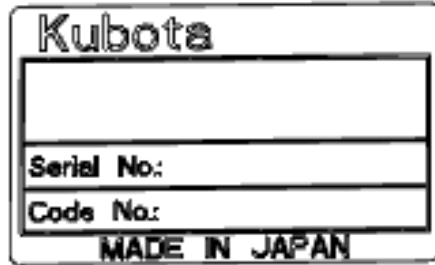

Fig. Engine - D1703-M-IDI-E3 (Stage IIIA)

- 1. Type plate
- 2. Engine series plate

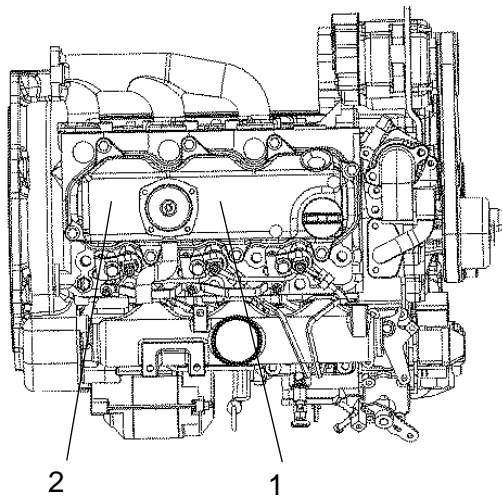

Fig. Engine - D1703-M-DI-E4B (Tier 4f, CS IV)

- 1. Type plate
- 2. Engine series plate

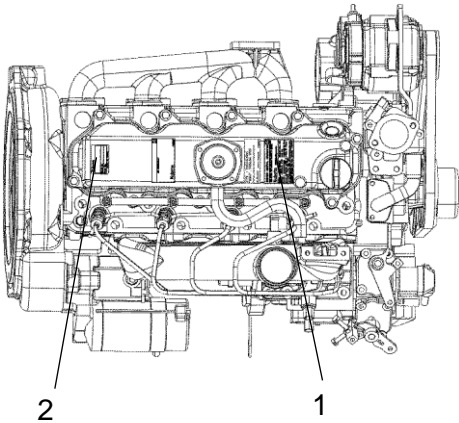



Fig. Engine - V2403-M (R96 & CS IV)

- 1. Type plate
- 2. Engine series plate

EMISSION CONTROL INFORMATION 	
THIS ENGINE MEETS 2008 Int. Tier4 EMISSION REGULATIONS FOR U. S. EPA AND CALIFORNIA NONROAD CI ENGINES.	
Kubota KUBOTA Corporation	
MODEL :	ENGINE
FAMILY :	ECS: EM
POWER :	CATEGORY:
VALVE CLEARANCE (COLD) :	
INJ. TIMING:	
LOW SULFUR DIESEL OR ULTRA LOW SULFUR DIESEL FUEL ONLY	
CONTACT KUBOTA FOR FUEL SETTING.	1H239-2

Location - decals (CC1200VI)

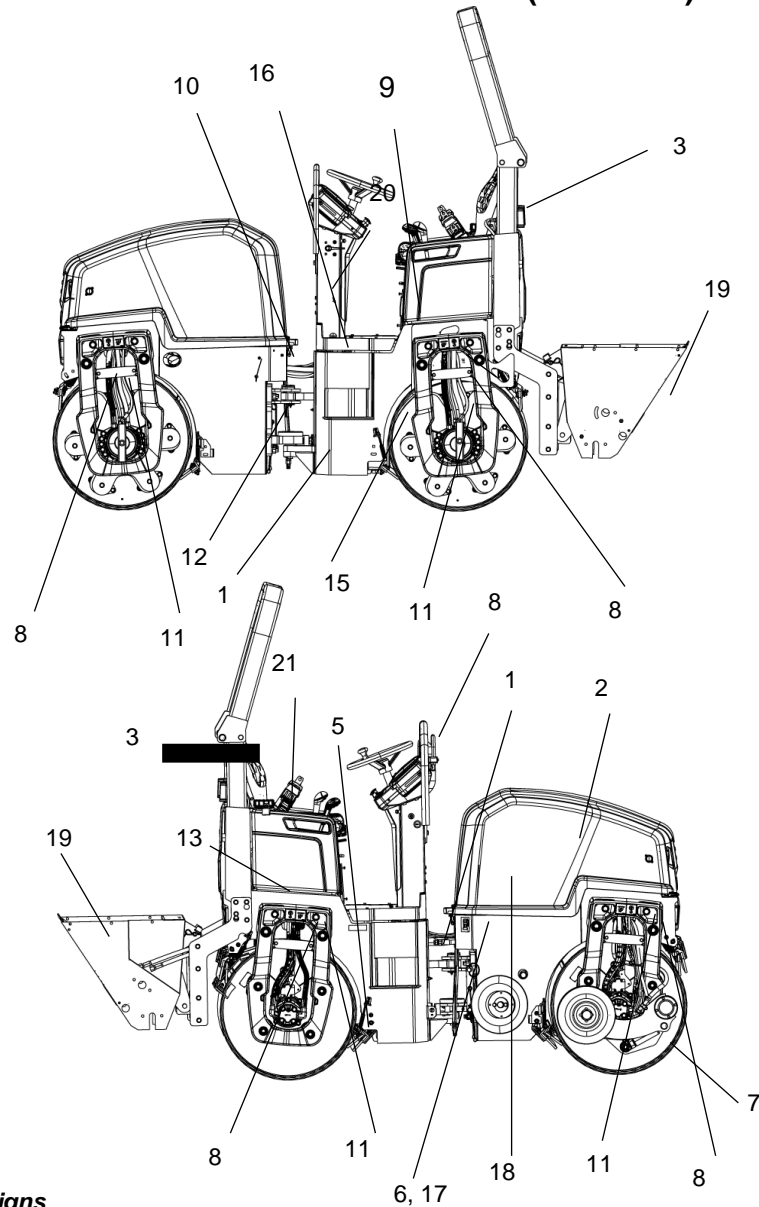

Fig. Location, decals and signs

1.	Warning, Crush zone	4700903422	12.	Sound power level	4700791292
2.	Warning, Rotating engine components	4700903423	13.	Hydraulic fluid level	4700272373
3.	Warning, Crushing risk	4700908229	14.	Warning, Starting gas	4700791642
4.	Warning, Instruction manual	4700903459	15.	Warning, Locking during transport	4812125363
5.	Warning, Hot surfaces	4700903424	16.	Flow divider (optional)	4700355981
6.	Diesel fuel (Stage IIIA)	4700991658	17.	Diesel fuel (Tier 4f, Stag 3 V)	4811000345
7.	Warning, edge cutter	4700904083	18.	Fuel with ultra low sulphur content (Tier 4f, CS IV)	4811000344
8.	Lifting point	4700357587	19.	Warning - Chip spreader, rotating components	4811000080
9.	Manual compartment	4700903425	20.	Location - decals, CALIFORNIA Proposition 65	4812129673
10.	Battery disconnecter	4700904835	21.	Forward / Reverse lever	4812130376
11.	Fixing point	4700382751			

Location - decals (CC1300 VI / CC1400 VI)

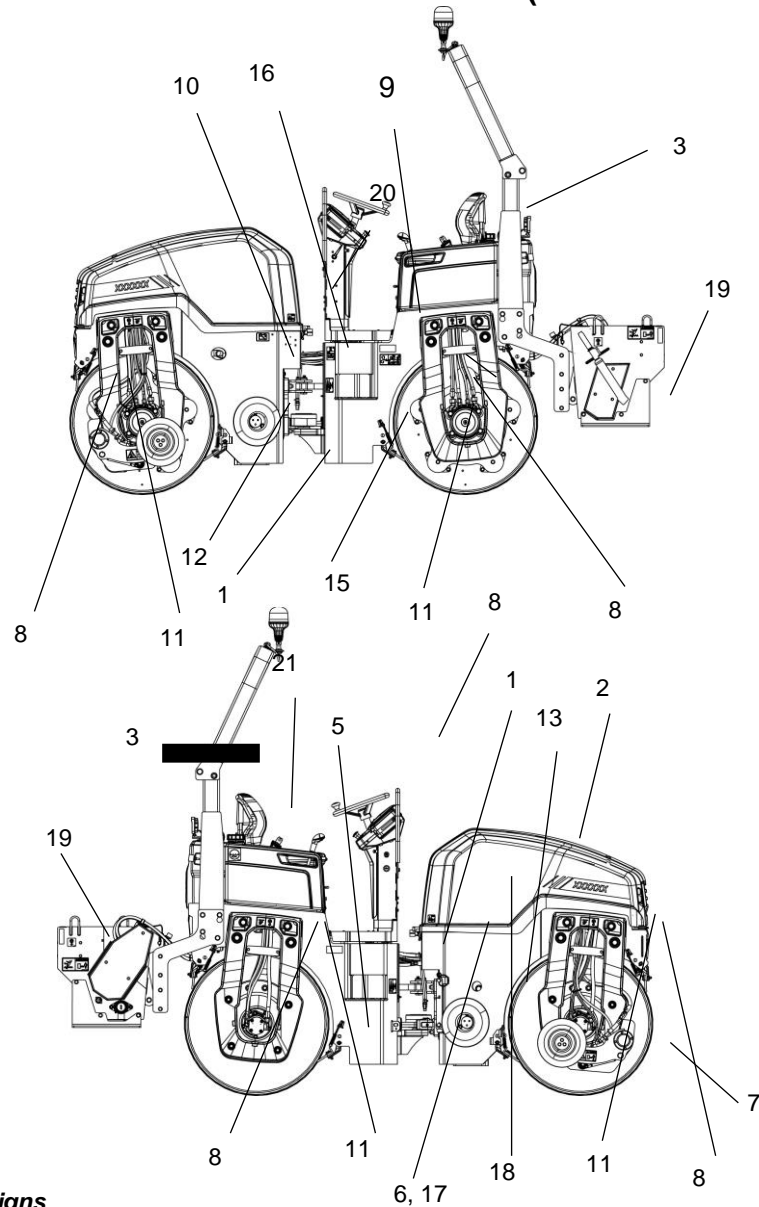
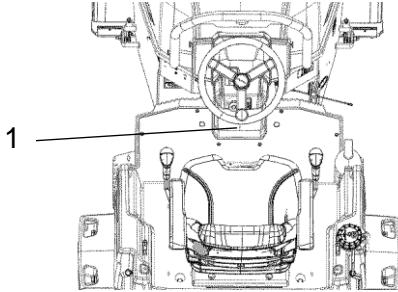

Fig. Location, decals and signs

1.	Warning, Crush zone	4700903422	12.	Sound power level	4700791292
2.	Warning, Rotating engine components	4700903423	13.	Hydraulic fluid level	4700272373
3.	Warning, Crushing risk	4700908229	14.	Warning, Starting gas	4700791642
4.	Warning, Instruction manual	4700903459	15.	Warning, Locking during transport	4812125363
5.	Warning, Hot surfaces	4700903424	16.	Flow divider (optional)	4700355981
6.	Diesel fuel (Stage IIIA)	4700991658	17.	Diesel fuel (Tier 4f / Stage V)	4811000345
7.	Warning, edge cutter	4700904083	18.	Fuel with ultra low sulphur content (Tier 4f / CS IV)	4811000344
8.	Lifting point	4700357587	19.	Warning - Chip spreader, rotating components	4811000080
9.	Manual compartment	4700903425	20.	Location - decals, CALIFORNIA Proposition 65	4812129673
10.	Battery disconnecter	4700904835	21.	Forward / Reverse lever	4812130376
11.	Fixing point	4700382751			

Location - decals, CALIFORNIA

Proposition 65



- 1. Warning, CALIFORNIA Proposition 65

4812129673

Fig. Location

Safety decals

Always make sure that all safety decals are completely legible, and remove dirt or order new decals if they have become illegible. Use the part number specified on each decal.

If a part is replaced and this part have a decal, make sure to also order the decal.

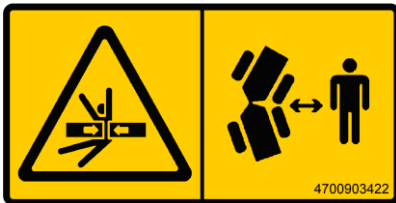

4700903422

Warning - Crush zone, articulation/drum.

Maintain a safe distance from the crush zone.

(Two crush zones on machines fitted with pivotal steering)

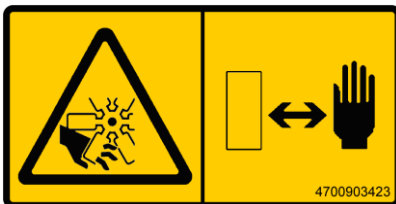

4700903423

Warning - Rotating engine components.

Keep your hands at a safe distance.

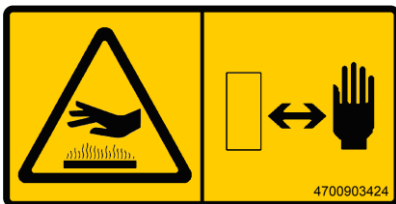

4700903424

Warning - Hot surfaces in the engine compartment.

Keep your hands at a safe distance.



4700903459
Warning - Instruction manual

The operator must read the safety, operation and maintenance instructions before operating the machine.

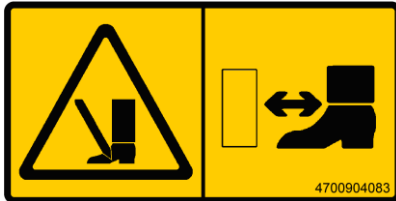

4700904083
Warning - Edge cutter (optional)

Warning of rotating parts.

Maintain a safe distance from the crush zone.



4700903422
Warning - Crush zone, chip spreader (optional)

Risk of personal injury or being crushed.

Keep well clear of the spreader's working area



4700908229
Warning - Risk of crushing

The articulation must be locked when lifting.

Read the instruction manual.

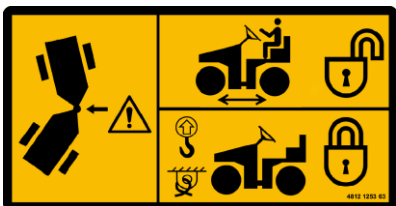

4812125363
Warning - Locking

The articulation must be locked during transport and lifting,

but be open during operation.

Read the instruction manual.



4700791642
Warning - Starting gas

Starting gas is not to be used.

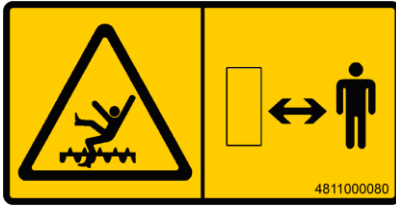

4811000080
Warning - Chip spreader (optional)

The spreader has rotating components.

Never insert your hands or any objects when the spreader is in operation.

Always stop the roller motor before carrying out adjustments or maintenance on the spreader.

4812129673
Warning

CALIFORNIA- Proposition 65



WARNING

Breathing diesel engine exhaust exposes you to chemicals known to the State of California to cause cancer and birth defects or other reproductive harm.

- Always start and operate the engine in a well-ventilated area.
- If in an enclosed area, vent the exhaust to the outside.
- Do not modify or tamper with the exhaust system.
- Do not idle the engine except as necessary.

For more information go to
www.P65warnings.ca.gov/diesel

4812129673

Info decals

Noise power level



Diesel fuel



Lifting point



Manual compartment



Battery disconnecter

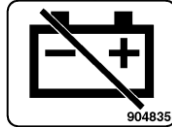

Fixing point



Bio hydraulic fluid, PANOLIN



Hydraulic fluid level

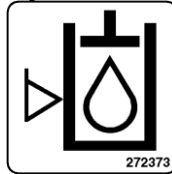

Water

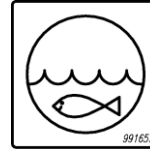

Flow divider (optional)



Fuel with ultra low sulphur content (Tier 4f / CS IV)



(Tier 4f / CS IV)

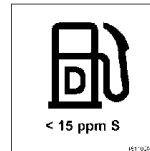

Forward- / Reverse lever

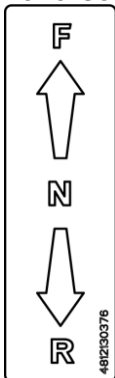

Instruments/Controls

Locations - Control panel and controls

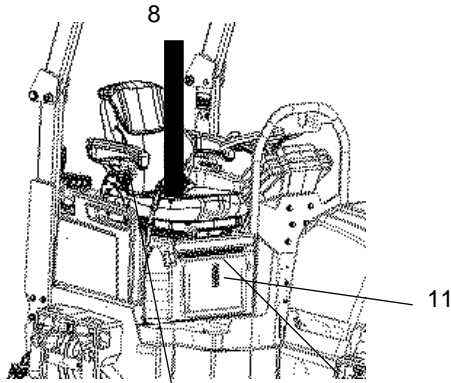

Fig. Operator position

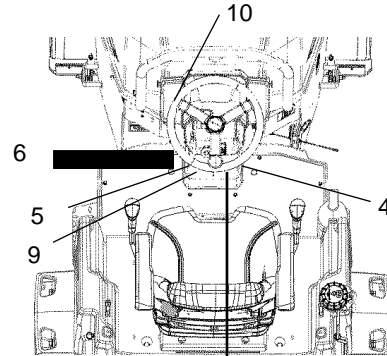
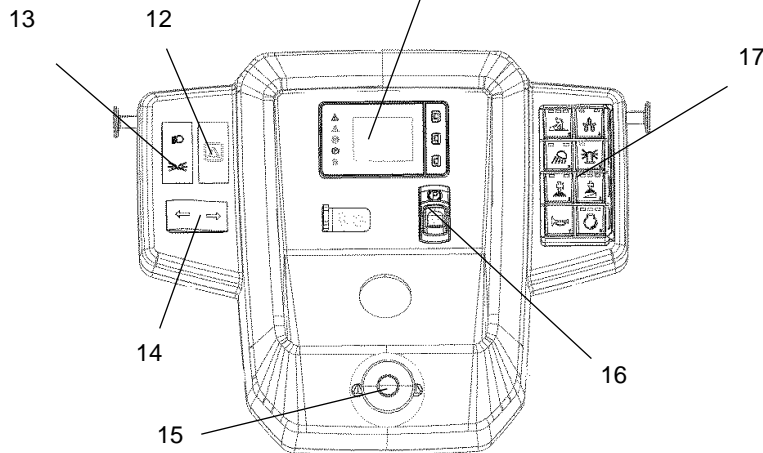
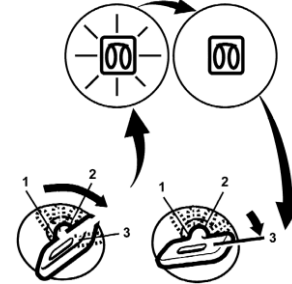
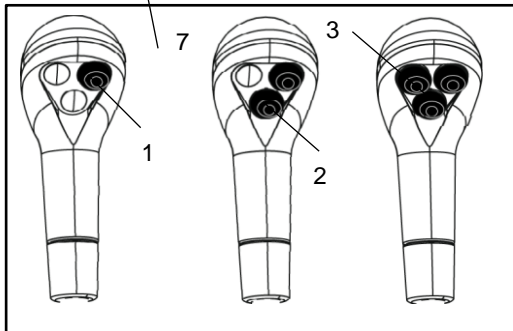
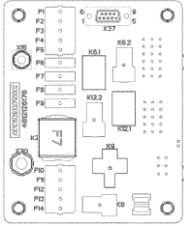

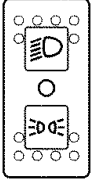
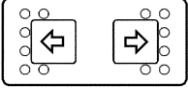

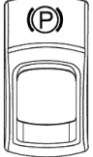

Fig. Operator's station







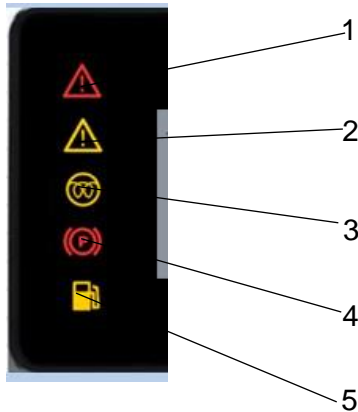

- | | | | | | |
|----|--|-----|---------------------|-----|---------------------------------|
| 4. | Ignitionkey | 9. | Fuse holder | 14. | * Directionselector / indicator |
| 5. | Engine speed control (D1703 / V2203-M/V2403-M) | 10. | Instrumentcover | 15. | Emergency stop |
| 6. | * Flow divider | 11. | Storage compartment | 16. | Parking brake |
| 7. | Forward/Reverse lever | 12. | * Hazard indicators | 17. | Membrane panel / Function keys |
| 8. | Seat switch | 13. | * Drivinglights | 18. | Control panel/Display |
- * = Optional

Function description









No	Designation	Symbol	Function
2.	Throttle control		In forward position, the engine idles. In backward position, the engine runs at full speed.
7.	Seat switch		Remain seated at all times when operating the roller. If the operator stands up during operation, a buzzer sounds. After 4 seconds the brakes are activated and the engine stops.
8.	Fuse and relay holder (on control column)		Contains fuses for the electrical system. See under the heading 'Electrical system' for a description of fuse functions.
9.	Instrument cover		Lowered over the instrument plate to protect the instruments from the weather and sabotage. Lockable
16.	Hazard warning lights, switch (Optional)		When depressed, the hazard warning lights are on
14.	Driving lights, switch (Optional)		Upper position = Traffic lighting goes on Intermediate position = Lighting switched off Lower position = Parking light goes on
18.	Direction indicators, switch (Optional)		When depressed to the left, the left direction indicators are on etc. In the middle position the function is shut off.
3.	Emergency stop		When pressed, the emergency stop is activated. The engine switches off and the brakes are activated. Brace yourself for a sudden stop.
31.	Parking brake On/Off, switch		To activate the brakes, press the top of the switch to change the position of the lever. To disengage the brakes, press down the red part at the same time as the switch, and change the position of the lever. NOTE: When starting the machine, the parking brake must be activated. Always use the parking brake when the machine is stationary on a sloping surface.

Function description - Alarm



No	Symbol	Designation and Function
1.		Warning lamp (Red)
		Serious fault: Switch off engine immediately! Launched together with a message on the display.
2.		Warning lamp (Yellow)
		Less serious fault: Rectify as soon as possible. Launched together with a message on the display.
3.		Glowing (Yellow)
		The symbol must go out before the ignition key is moved to position II, for activation of the starter motor.
4.		Parking brake indicator (Red)
		The symbol lights when the parking brake is activated.
5.		Fuel level (Yellow)
		The symbol lights when there is 10% fuel remaining in the fuel tank.







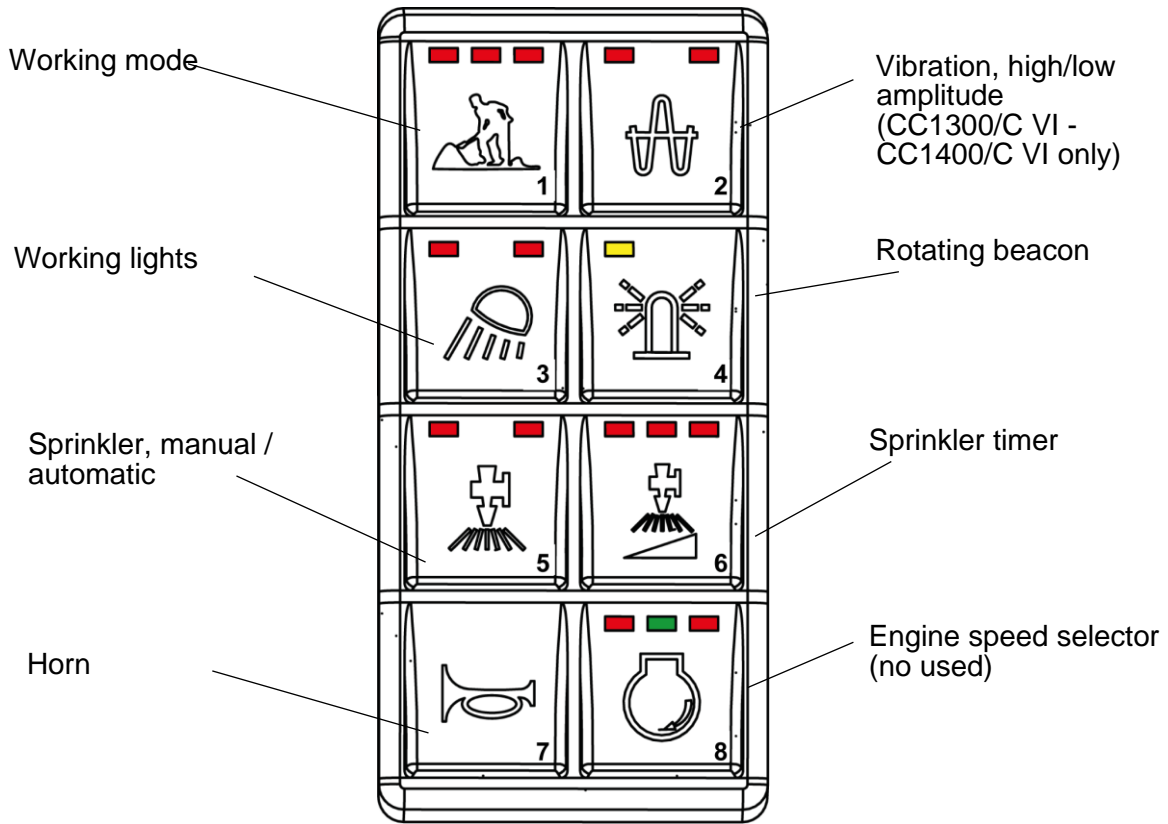



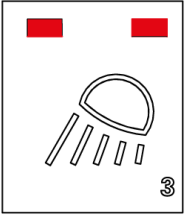



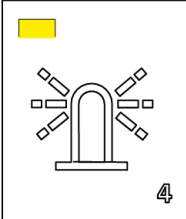

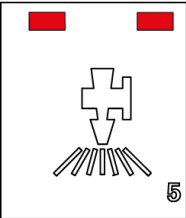

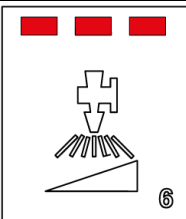

Machine alarm

Symbol	Designation	Function
	Warning symbol, hydraulic fluid filter	If the symbol is shown when the diesel engine is running at full speed, the hydraulic fluid filter must be changed.
	Warning symbol, clogged air filter	If this symbol is shown when the engine is running at full speed, the air filter must be checked/replaced.
	Warning symbol, battery charging	If the symbol is shown when the engine is running, then the alternator is not charging. Switch off the engine and locate the fault.
	Warning symbol, engine temperature	If this symbol is shown, the engine is too hot. Stop the engine immediately and locate the fault. Refer also to the engine manual.
	Warning symbol, hydraulic fluid temperature	If this symbol is shown, the hydraulic fluid is too hot. Do not drive the roller; allow the fluid to cool by running the engine on idle, and then locate the fault.
	Warning symbol, low fuel level	Less than 10% of the fuel is left if this symbol is shown.
	Warning symbol, low sprinkler water level	If this symbol is shown, there is less than 10% of the sprinkler water left in the main tank.
	Warning symbol, low oil pressure, diesel engine	If this symbol is shown, the engine's oil pressure is too low. Switch off the engine immediately.
	Warning symbol, water in the fuel	If this symbol is shown, the engine must be stopped and the fuel pre-filter drained of water.

Functional description - Membrane panel

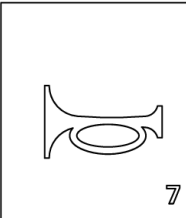
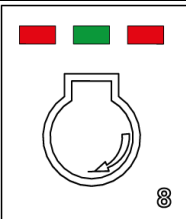

LED	Designation	Function	LED	LED color
	Working mode (vibration and edge cutter optional) permitted	Activates working mode, which makes it possible to use vibration and edge cutter (optional).		
		LED OFF = Transport mode		-
		LED LEFT = Working mode, vibration		Red
		LED CENTER = Working mode, edge cutter (Optional)		
	Vibration, High/Low amplitude (accessory) (only CC1300/C VI - CC1400/C VI)	Enables vibration with high or low amplitude		
		LED LEFT = Low Amplitude		Red
		LED RIGHT = High Amplitude		

LED	Designation	Function	LED	LED color
	Working lights, switch	Enables working lights for ROPS and / or Frame		
		LED OFF = OFF		
		LED LEFT = Working lights, Frame		Red
		LED RIGHT = Working lights, Frame and ROPS (Optional)		
	Rotating beacon, switch (Optional)	Enables the rotating beacon		
		LED Off = OFF		-
		LED LEFT = ON		Yellow
	Sprinkler, manual / automatic	Enables the sprinkler system		
		LED OFF = No function		-
		LED LEFT = Manual sprinkler		Red
		LED RIGHT = Automatic sprinkler		
	Sprinkler timer			
		LED OFF = No timer function Continuously on when the lever is not in the neutral position.		-
		LED LEFT = Minimal amount of water		Red
		LED CENTER = Increased amount of water		
		LED RIGHT = Maximal amount of water		
	Horn, switch	Press to sound the horn.		
	Engine speed selector (no used)	Only activated for electronic controlled engine speed (no used)		
		LED LEFT = Low speed		Red
		LED CENTER = ECO low working revs		Green
		LED RIGHT = High working revs		Red

Function description, buttons on Forward/Reverse lever

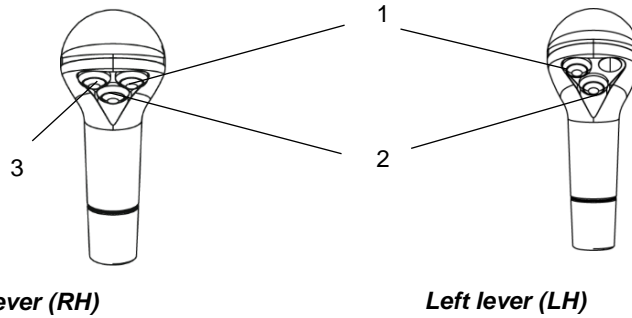

Mode / Button	LED	Button 1	Button 2	Button 3
Transport mode	0	None	None	Edge cutter, up
Working mode	1	Vibration, front	Vibration, rear	Edge cutter, up
Edge cutter mode	2	Vibration, front	Edge cutter, down	Edge cutter, up
Spreader mode	3	Vibration, front	Spreader	Edge cutter, up

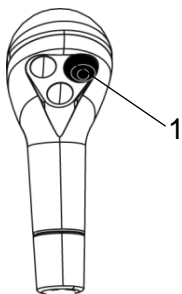

Standard equipped machine.

Fig. Forward/Reverse lever right
1. Vibration on/off

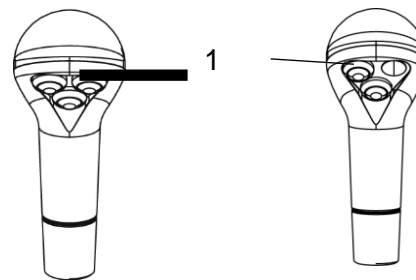

Machine with dual controls (option).

Fig. Double forward/reverse lever
1. Vibration on/off

Speed adjustment and vibration frequency (CC1200/C VI - CC1400/C VI with single amplitude)

Mechanical speed control

If the speed control is in the center position / ECO (2), both the engine speed and vibration frequency are low.

If the speed control is in the lowermost position / ECO (3), both the engine speed and vibration frequency are high.

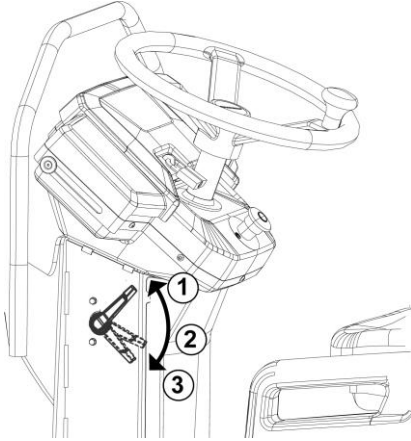

Fig. Mechanical speed control

1. Control in idle mode
2. Control in center position / ECO
3. Control in lowermost position

Electronic speed control

If the LED lamp in the center is lit green (ECO), **Low** engine speed and **low** vibration frequency are selected.

If the LED lamp to the right is lit red, **High** engine speed and **high** frequency are selected.

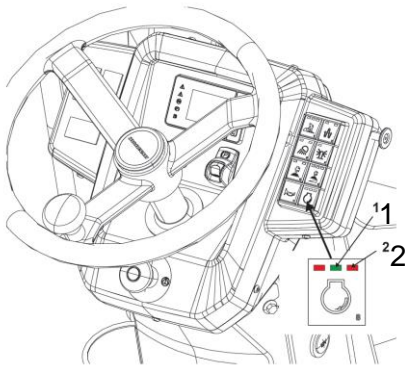

Fig. Electronic speed control

1. LED lamp for Low speed / frequency (ECO)
2. LED lamp for High speed / frequency

Navigation submenus

Stage IIIA	Navigation sequence Submenu	CS IV / Tier 4f
Transport mode / Machine hours	1st press	Transport mode / Machine hours
Error code list	2nd press	Regeneration
User settings	3rd press	Error code list
Transport mode / Machine hours	4th press	User settings
	5th press	Transport mode / Machine hours

Function description - Display

Display explanations



Fig. Start-up image

When the ignition switch is activated to position I, a start-up image is shown on the display. This image is visible for three seconds and then changes to Transport/Working mode, depending on which mode is selected on the membrane panel.

The transport mode menu is shown when one of the three function keys to the right on the display is activated.



Transport mode

The transport mode screen provides information about travel direction (3), machine hours (4) and fuel level (2).

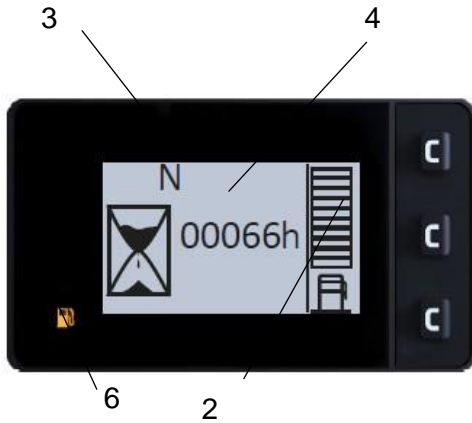

Fig. Transport mode - Fuel level, low

2. Fuel level:

- The fuel level is indicated as a percentage (%) on the bar to the right of the display. When only the lowest step on the bar is filled, there is 10% of the fuel remaining in the tank and the warning lamp for the fuel level (6) lights.

3. Direction of travel

- The icon has three options (F, N, R) and is shown in the top left of the display. Only current status is displayed.

- **N** (Neutral) shows that the control lever is in the neutral position and no travel direction arrow is shown on the display.

- **F** (Forwards) an arrow directed left is shown in front of "F" on the display.

- **R** (Backwards) an arrow directed right is shown after "R" on the display.

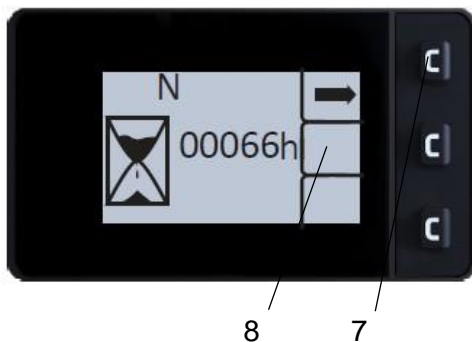

Fig. Transport mode - Machine hours

The side view (8) opens the first time the uppermost button (7) is pressed.

If no activity occurs after 20 seconds, the display returns to the main menu.

The second press of the button (7) displays an error code list.

On machines with **CR** engines, the regeneration mode is displayed instead.

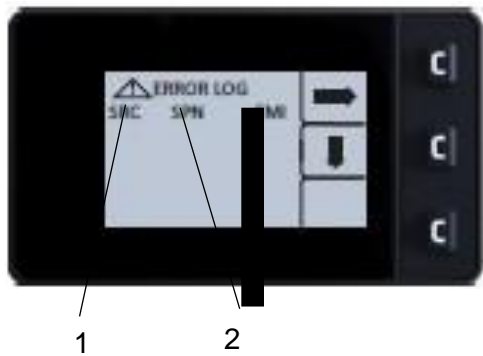

Fig. Submenu, Error code list
 1. SRC: Error source
 2. SPN / FMI: Error code type

Submenu - Error code list

1. The alarm symbols are shown on the left-hand side of the display. At the top is the red (5) warning symbol and at the bottom the yellow (6).

Alarms are categorized in different degrees of severity:

White alarm: The lowest degree of severity. These do not result in any of the warning lamps lighting, but are intended as information.

Yellow alarm: The middle degree of severity. Together with the error code, the yellow warning light will also come on.

Red alarm: The highest degree of severity. Together with the error code, the red warning light will also come on.

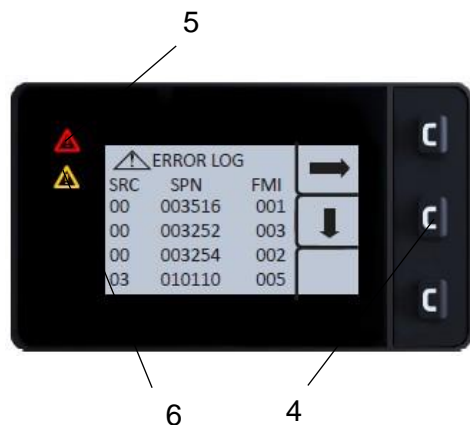

Fig. Sub-menu, Error code list
 5. Red warning symbol (Serious fault)
 6. Yellow warning symbol (Less serious fault)

2. The middle button (4) on the side menu shows a downward arrow. This arrow is used to scroll through the list.

3. A Red or Yellow control lamp gives a reminder until the error is rectified.

User settings

The user can change the light settings (day mode (9) / night mode (10)), choose between the Metric or Imperial unit system (14) and also read version of installed software for display (11) and ECU (12).

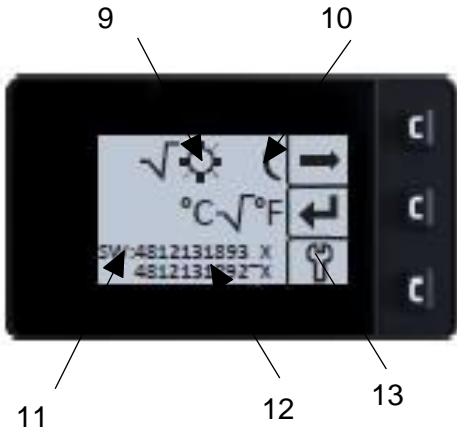

Fig. User settings

- 9. Light settings, Day mode
- 10. Light settings, Night mode
- 11. Software version, Display
- 12. Software version, ECU
- 13. To service / test site

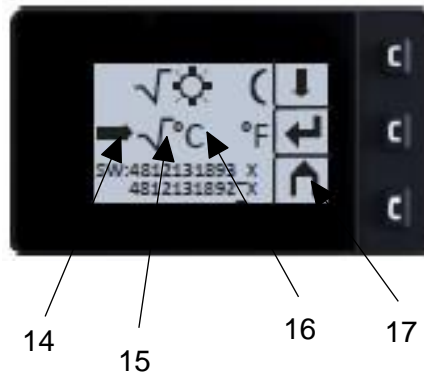

Fig. User settings

- 14. Cursor
- 15. Section selector
- 16. Metric / Imperial unit
- 17. Start menu



"SERVICE MENU"

The service menu is also accessible via the main menu for adjustments.



"ADJUSTMENTS"

1

2

3

CALIBRATION - service personnel only, requires a PIN code.

The value of the number increases or decreases using button 1 or 3 respectively.

Button 2 confirms the value and the indication moves to the next number.

Control lever calibration

1. Move the control lever to its foremost position.
2. Press "**Enter**" (12) to save the value. The calibration indication now moves to "NEUTRAL".
3. Move the control lever back to the neutral position.
4. Press "**Enter**" (12) to save the value. The calibration indication now moves to "REVERSE".
5. Move the control lever back to the reverse position.
6. Press "**Enter**" (12) to save the value.
7. Press "**Enter**" (12) to save the value in the control unit.

When calibrating the joystick, the values must always be between the following limits:

Forward (**F**): 200 - 700

Neutral (**N**): 2200 - 2800

Reverse (**R**): 4200 - 4700

8. "**OK**" is shown at the bottom of the display when saving is complete. "**ERROR**" is shown at the bottom of the display if the values are outside of the aforementioned permitted limits. Redo the calibration.



12



Working mode, Vibration

The different working modes are selected with the help of the working mode button on the panel.

1. Optional asphalt temperature meter (see the chapter asphalt temperature meter)

Symbols are shown in the menu **Working mode, vibration** for forward and rear drums.

2. Compaction status (off/on) on front/rear drum

Press one of the buttons (7) on the far right of the panel. The side menu (8) will then appear on the display.

The lowermost button (7) activates AVC mode (Automatic Vibration Control), activation lights the AVC symbol (9).

Press the uppermost button (7) and the submenu is displayed.

The lowermost button (7) on the panel is pressed, AVC (9) is activated and the symbol in the bottom right of the display lights.

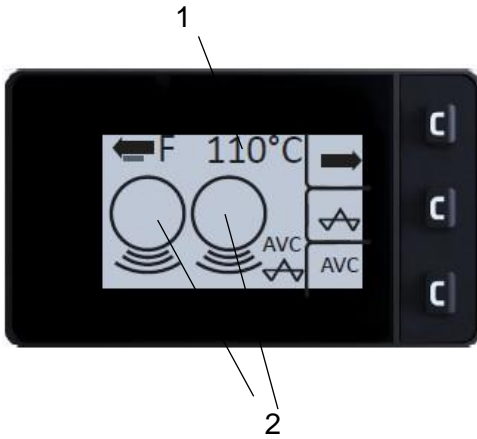

Fig. Working mode, Vibration both drums, AVC selected

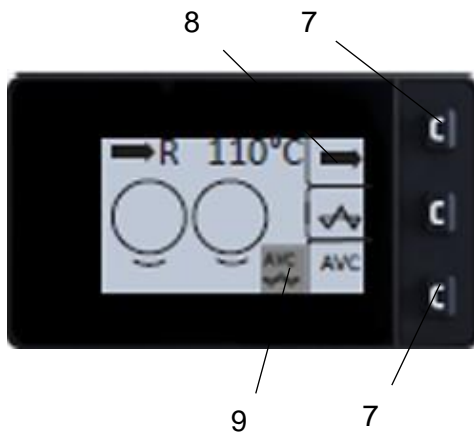

Fig. Working mode, Vibration both drums, AVC selected

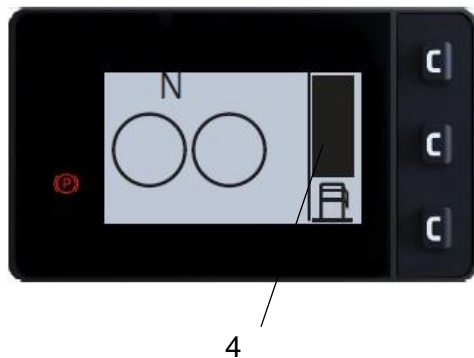
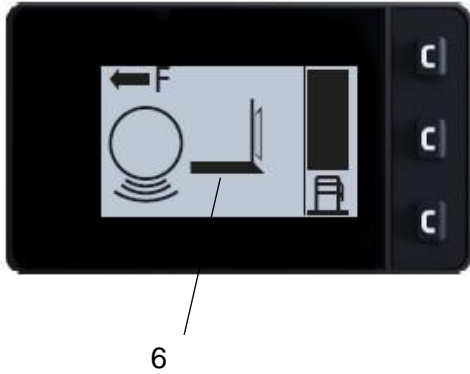

Fig. Working mode - Vibration Off



Working mode - Edge cutter

The different working modes are selected with the help of the working mode button on the panel.



In **Working mode, Edge cutter** a symbol is shown for the drum (front drum) and the symbol for the edge cutter (6).

Edge cutter maneuvering can only take place when high amplitude is selected and with the parking brake disabled. The round parts below the drum indicated the selected amplitude.

Fig. Working mode - Edge cutter

The edge cutter is maneuvered upward with button 3 on the control level. Provided that the parking brake is disabled maneuvering upward can always take place, irrespective of the selected mode on the membrane panel's working mode button.

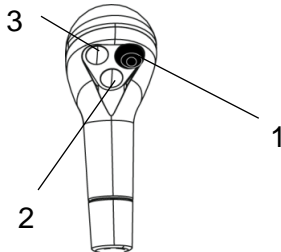

Maneuvering downward with button 2 on the control lever can only take place when **Working mode - Edge cutter** is selected and the parking brake is disabled.

Button function, Working mode, Edge cutter

Fig. Forward/Reverse lever right
 1. Vibration, front drum (on/off)
 2. Edge cutter, down
 3. Edge cutter, up



Working mode - Chip spreader

The different working modes are selected with the help of the button on the panel.

In **Working mode, Chip spreader** a symbol is shown for the drum (front drum) and the symbol for the chip spreader (3).

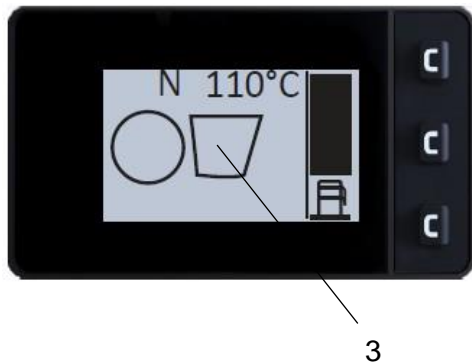

Fig. Working mode, Chip spreader (Off)

The chip spreader on and off is performed with button 3 on the control level.

Maneuvering can only take place when **Working mode - Chip spreader** is selected on the membrane panel's working mode button.

High amplitude and disabled parking brake must also be selected. The round parts below the drum indicated the selected amplitude.

The appearance of the chip spreader symbol changes depending on whether it is active or inactive.

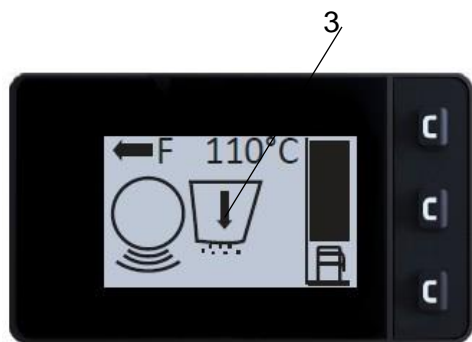
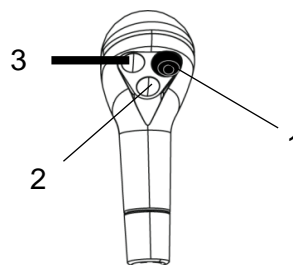

Fig. Working mode, Chip spreader (On)



Button function, Working mode, Chip spreader

Fig. Forward/Reverse lever right 1. Vibration, front drum (on/off) 2. Spreader, on/off 3. Edge cutter, up

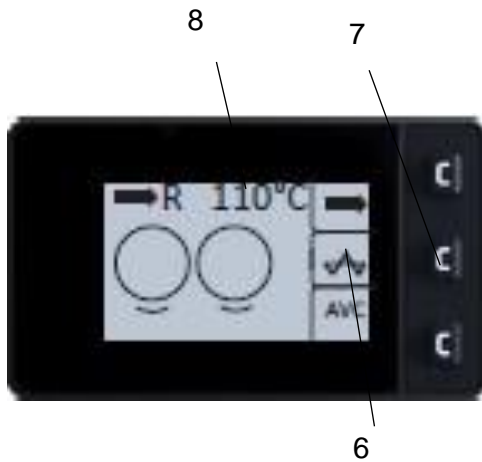

Fig. Working mode, Asphalt temperature meter

Asphalt temperature meter (Optional)

With the side menu (6) active, the asphalt temperature meter is accessed by pressing the button (7).

The asphalt temperature is displayed in the upper right corner (8) and the temperature display flashes if the temperature is outside the preset limits.

The lower and upper preset temperature limits are displayed on the left-hand side next to the icons (9 and 10).

The desired temperature limit can be set using the buttons 11 and 13. Confirm by pressing button 12.

For the lower temperature limit, 100 °C is the lowest adjustable limit. For the upper temperature limit, 150 °C is the lowest adjustable limit.

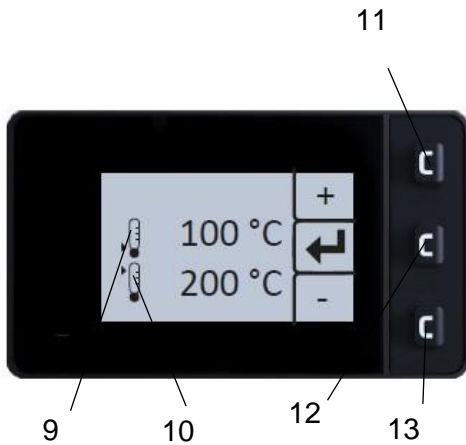

Fig. Asphalt temperature range setting

Operator help when starting

To start the diesel engine requires the following conditions to be met:

- Activated parking brake
- Control lever in neutral
- Engine speed selector in low position (Low = idling). Applies only to CR engines (electronically controlled engines) and there is no operator assistance here.



For conditions that are not met and operator assistance is available, respective symbols are shown on the display during attempted start-up.



Operator help Workmode

The working mode must be selected to activate vibration. This also applies to the options edge cutter and chip spreader.

Operator assistance (and the three LED indicators on the working mode selection button) indicate if activation is attempted without the working mode being selected.



Electrical system

Fuses on machine (CC1200VI)

The figure shows the position of the fuses.

The table below gives fuse amperage and function. All fuses are flat pin fuses.

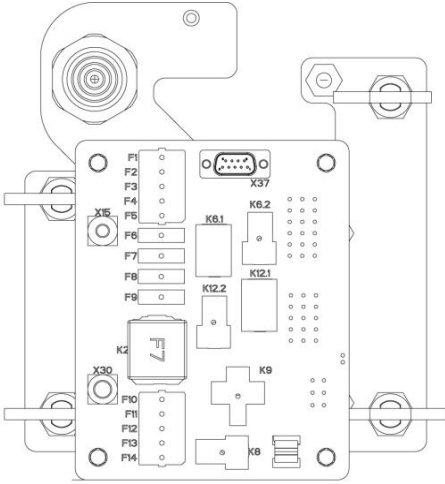

Fig. Fuse box

Fuse box

1.	F1	ECU	15A	9.	F8	Sprinkler	10A
2.	F2	ECU	7.5A	10.	F9	Sprinkler (Combi)	10A
3.	F3	Display, Membrane panel, Park brake	5A	11.	F10	Ignition key	5A
4.	F4	Joystick Push Button, Seat switch	5A	12.	F11	12 V outlet	10A
5.	F5	T3 Fuel pump, Generator	3A	13.	F12	ECU	0.5A
6.	F5	Tier 4f, CS IV Fuel pump, Generator, Engine sensor	3A	14.	F13	Driving lights, direction indicator	10A
7.	F6	Working lights ROPS or Water tank with 2 lights assembled	10A	15.	F14	Driving lights, Low beam	15A
8.	F7	Working lights frame	15A				

Electrical system

Fuses on machine (CC1300 VI / CC1400 VI)

The figure shows the position of the fuses.

The table below gives fuse amperage and function. All fuses are flat pin fuses.

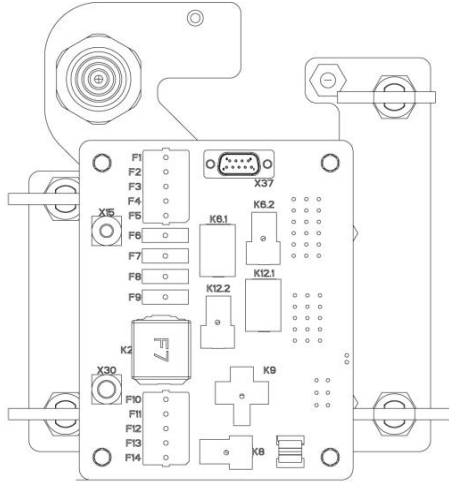

Fig. Fuse box

Fuse box

1.	F1	Spare	-	9.	F8	Sprinkler	10A
2.	F2	Spare	-	10.	F9	Sprinkler (Combi)	10A
3.	F3	Display, Membrane panel, Park brake	5A	11.	F10	Ignition key	5A
4.	F4	Joystick Push Bottom, Seat switch, Water tank level sensor, Asphalt temperature sensor	5A	12.	F11	ECU	15A
5.	F5	T3 Fuel pump, Generator	3A	13.	F12	ECU	7.5A
6.	F5	Tier 4f, CS IV Fuel pump, Generator, Water in fuel sensor, Air flow sensor, EGR	3A	14.	F13	Driving lights, direction indicator	10A
7.	F6	Working lights ROPS or Water tank with 2 lights assembled, Flow divider	10A	15.	F14	Driving lights, Low beam	15A
8.	F7	Working lights - frame, Edge cutter Up valve	15A				

Fuses at battery master disconnect switch

The figure shows the different positions of the fuses in the engine compartment.

The table below gives fuse amperage and function. All fuses are flat pin fuses.

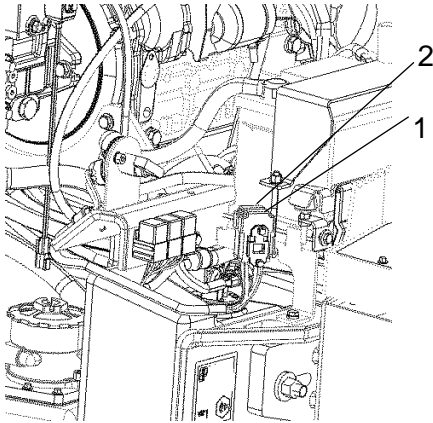

D1703 / V2403-M-DI-E3B (R96 & CS IV)

1.	F8	Main fuse	40A
2.	F14	Glowing, Start relay, Fuel solenoid	50A

Fig. Battery disconnecter and fuses (D1703 / V2403-M-E3B)

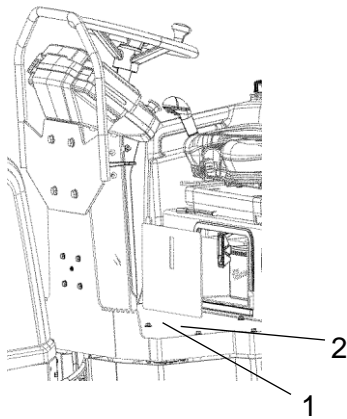

Fig. Operator's station
1. Control unit (ECU)
2. Floor plate

The control unit (ECU) (1) is located under the floor plate (2) on the platform.

This control unit manages, among others, automatic vibration control, automatic watering control and interlock.

Relays on machine

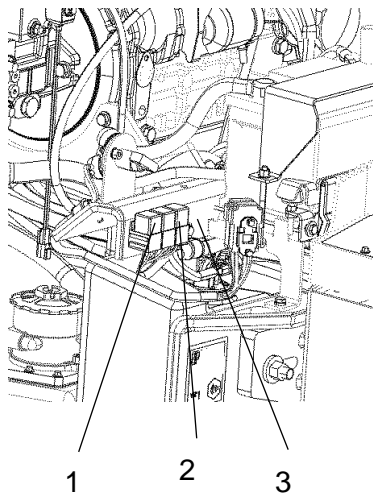
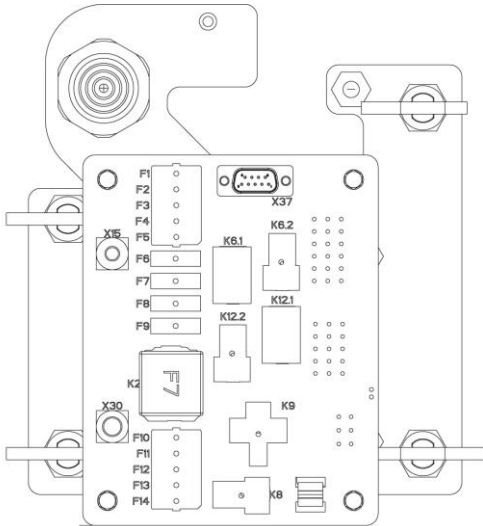

Fig. Relays Engine compartment
(D1703 / V2403-M-E3B)

Engine compartment (D1703 / V2403-M-DI-E3B(R96 & CS IV))

- | | | |
|----|----|---------------------|
| 1. | K1 | Starting |
| 2. | K3 | Fuel solenoid |
| 3. | K5 | Glowing / Preheater |



Steering column

- | | | |
|----|-------|-------------------------------------|
| 1. | K2 | ECU |
| 2. | K6.1 | Working lights frame |
| 3. | K6.2 | Working lights ROPS or Water tank |
| 4. | K8 | Driving lights |
| 5. | K9 | Driving lights, direction indicator |
| 6. | K12.1 | Sprinkler |
| 7. | K12.2 | Sprinkler (Combi) |

Fig. Relays in steering column

Operation

Before starting

Master switch - Switching on

Perform daily maintenance. See the maintenance instructions.

The battery disconnecter is on the left side in the engine compartment.

Turn the key (1) to switched on position. The roller is now supplied with power.

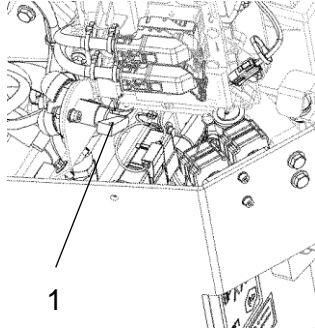

Fig. Engine compartment
1. Battery disconnecter



The engine hood must be unlocked during operation, unless the battery disconnecter is freely accessible from the outside, so that the battery voltage can be quickly disconnected if necessary.

Driver seat - Adjustment

Adjust the operator's seat so that the position is comfortable and so that the controls are within easy reach.

The tables below show the adjustments that can be made on the different seats.

The image below to the left shows a fully equipped luxury comfort seat while the image below to the right shows a normally equipped comfort seat.



Always make sure that the seat is secure before beginning operation.



Remember to use the seat belt (9).

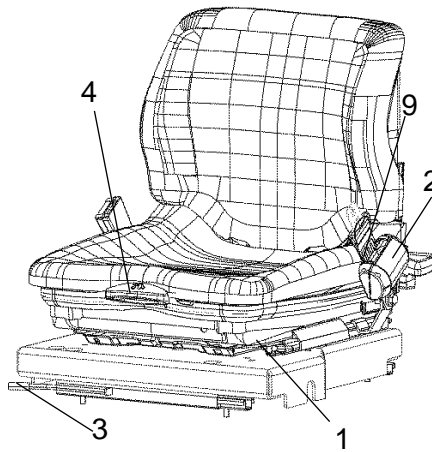
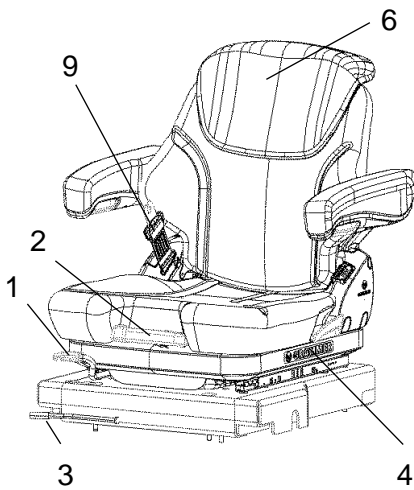

Fig. Driver seat (MSG65)

- 1. Locking lever - Length adjustment
- 2. Weight adjustment
- 4. Backrest inclination
- 9. Seat belt

Fig. Driver seat (MSG20)

- 1. Locking lever - Length adjustment
- 2. Weight adjustment
- 4. Backrest inclination
- 9. Seat belt

	Length adjustment (1)	Weight adjustment (2)	Side travel (3)	Backrest inclination (4)
Standard seat	x			
Comfort seat	x	x	(Optional)	x
Luxury comfort seat	x	x	(Optional)	x

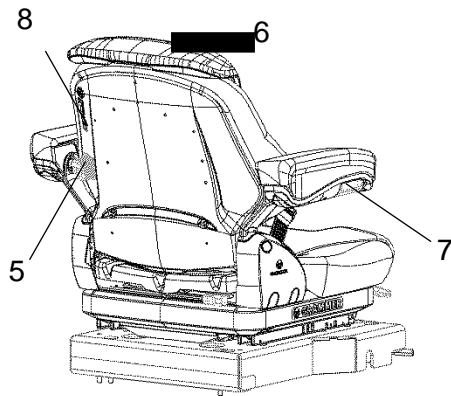

Fig. Driver seat (MSG65)
5. Lumbar support adjustment
6. Backrest extension
7. Armrest, adjustable
8. Seat heating

	Lumbar support adjustment (5)	Backrest extension (6)	Armrest, adjustable (7)	Seat heating (8)
Standard seat				
Comfort seat				
Luxury comfort seat	X	X	X	X

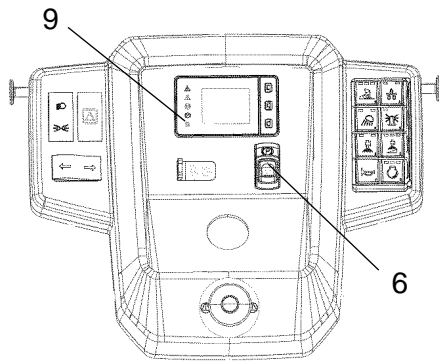

Fig. Instrument panel
6. Parking brake
9. Brake warning lamp

Parking brake - Check



Make sure that the parking brake (6) is activated. The roller can start to roll if the parking brake is not applied.



Check the function of the parking brake by activating the parking brake when the roller is moving very slowly forwards/backwards. (Check in both directions). Hold the steering wheel and brace yourself for a sudden stop when the brakes are activated. The engine does not switch off.



The engine can only be started with the parking brake (6) activated.

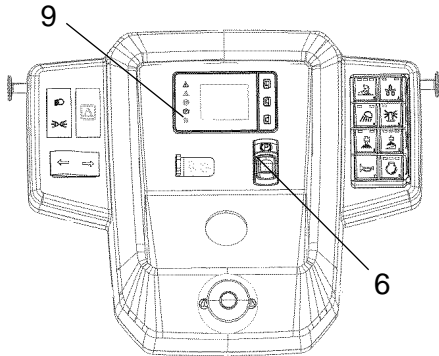

Reserve brake - Control

Drive slowly forwards/backwards and press down the parking brake button (6) to activate it.

The roller must now stop immediately.

Fig. Instrument panel
6. Parking brake
9. Brake warning lamp

Instruments and lamps - Checking



Make sure that the emergency stop button is pulled out and the parking brake is activated.

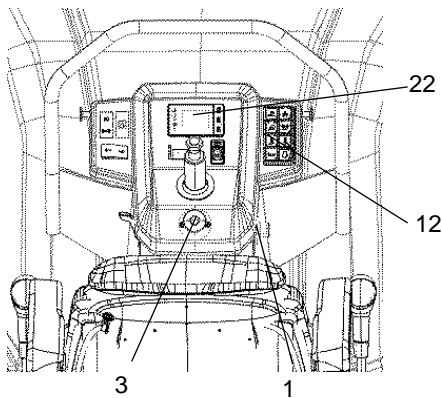

Fig. Instrument panel
1. Ignition key
3. Emergency stop
12. Sprinkler activation button
22. Display

Turn the ignition key (1) to position 2.

Check that the warning symbols are shown on the display (22).

Activate the front sprinkler button (12) to the operating position, and check that the system works.

Interlock

The roller is equipped with Interlock.

The diesel engine will switch off after 4 seconds if the operator gets off the seat when going forwards/backwards.

If the control is in neutral when the operator stands up a buzzer will go on until the parking brake button is activated.

If the parking brake remains inactive, the diesel engine turns off after 4 seconds.

The engine does not stop if the parking brake is activated.

The diesel engine will switch off immediately if for any reason the forward/reverse lever is moved out of neutral when the operator is not sitting down and the parking brake button has not been activated.



Sit down for all operations!

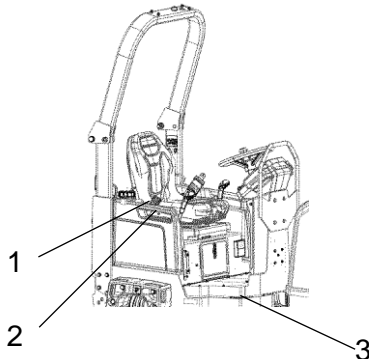

Fig. Operator's station

1. Seat belt
2. Safety railing
3. Rubber element

Operator position

If a ROPS (Roll Over Protective Structure) is fitted to the roller, always wear the seat belt (1) and wear a protective helmet.



Always replace the seat belt (1) if it shows signs of wear or has been subjected to excessive strain.



Check that the platform's rubber elements (3) are in good condition. If the elements are worn this will have a negative effect on comfort.



Ensure that the platform floor is clean to avoid the risk of slipping.

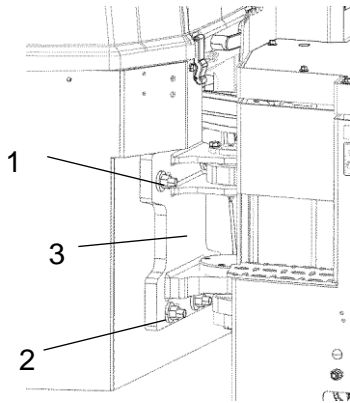

Fig. Articulated joint
1. Nut
2. Washer
3. Articulated joint holder

Adjusting the Off-set

Lift up the front drum just above ground level.

Place a jack on the rear frame, to support the articulated joint, and loosen the nuts on the articulated joint (1).

Position yourself on the right or left-hand side of the articulated joint.

Use the requisite tools (for example, a rubber covered steel bar) and hit the articulated joint holder (3). The articulated joint holder now moves sideways.

When the adjustment is made, make sure to tighten the nuts on the articulated joint (1) to the right torque again.

(See the table for tightening torque in the “Technical data” chapter)

Flow divider (Optional)

The switch on the floor (to the left) must be pressed down to activate the flow divider.

The flow divider is enabled as long as the switch is actuated.

Remove your foot from the switch to disable the flow divider.

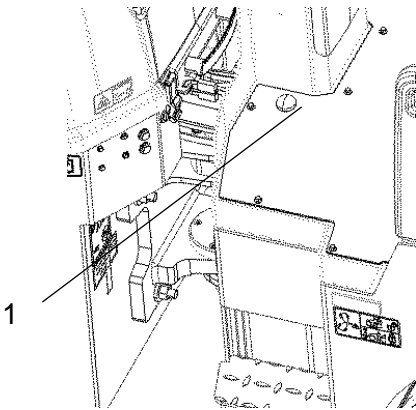

Fig. Operator platform
1. Flow divider switch

Starting

Starting the engine

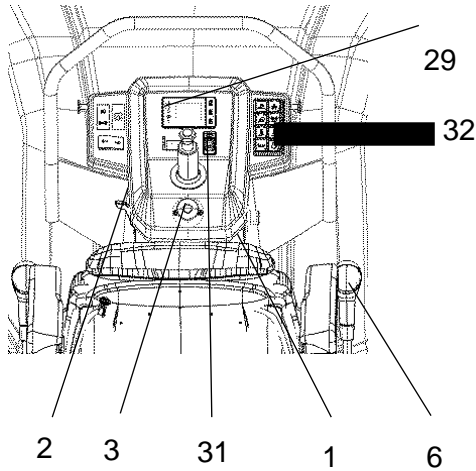

Fig. Control panel

- 1. Ignition key
- 2. Throttle control (D1703/V2203-M-E3B)
- 3. Emergency stop
- 6. Forward/Reverse lever
- 29. Glow lamp
- 31. Parking brake
- 32. Engine speed selector
(no used)



The operator must remain seated when starting.

Make sure that the emergency stop (3) is pulled out and the parking brake (31) is activated.

Set the forward/reverse lever (6) in neutral. The engine can only be started when the lever is in neutral.



Do not run the starter motor for too long. If the engine does not start, wait a minute or so before trying again.

D1703 / V2403-M-DI-E3B(R96 & CS IV)

At high ambient temperatures, set the engine speed control (2) to the position just over idling.

On cold start, set the engine speed control to medium revs. Preheating: Turn the ignition key to position II. When the glow lamp (29) goes out: Turn the ignition key (1) to the right. As soon as the engine starts, release the ignition key and reduce the engine speed to just over idling (because high revs can damage a cold engine). As soon as the engine is running smoothly, reduce the revs down to idling.



**If the parking brake is not activated and the forward/reverse lever is in neutral, the parking brake and jump start symbols will be lit on the display.
The machine cannot be started.**

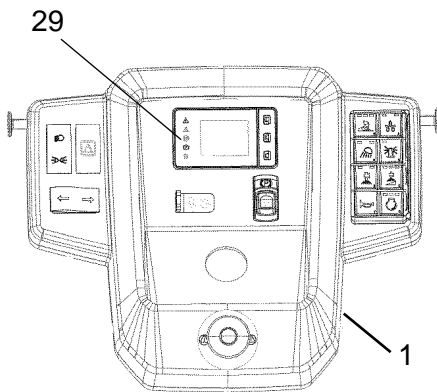

Check while warming up the engine that no warning lamps are lit.

The parking brake lamp (25) will remain on for as long as the parking brake switch is activated.



When starting and driving a machine that is cold, remember that the hydraulic fluid is also cold and that braking distances can be longer than normal until the machine reaches the working temperature.

Fig. Instrument panel
1. Ignition key
29. Glow lamp

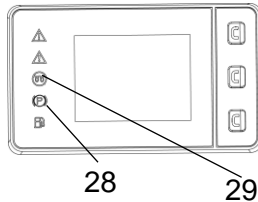

Ensure that there is good ventilation (air extraction) if the engine is run indoors. Risk of carbon monoxide poisoning.

Fig. Control panel
25. Parking brake lamp
29. Glow lamp

Driving

Operating the roller



Under no circumstances is the machine to be operated from the ground. The operator must be seated inside the machine during all operation.



Make sure that the area in front of and behind the roller is clear.

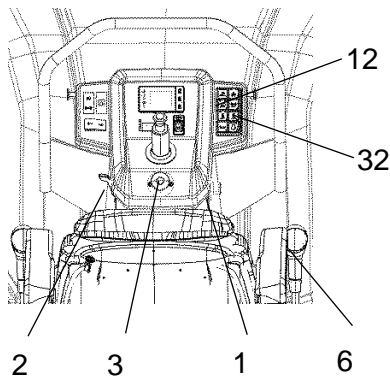

Fig. Instrument panel

- 1. Ignition key**
- 2. Throttle control (D1703 / V2203-M-E3B)**
- 3. Emergency stop**
- 6. Forward/Reverse lever**
- 32. Engine speed selector (no used)**

Release the parking brake and check that the parking brake lamp goes off.

D1703 / V2403-M-DI-E3B(R96 & CS IV)

Turn the throttle control (2) in backward position.

Check that the steering is working correctly by turning the steering wheel once to the right and once to the left while the roller is stationary.

When compacting asphalt, remember to enable the sprinkler system (12).

Interlock/Emergency stop/Parking brake - Check



The interlock, emergency stop and parking brake must be checked daily before operating. A function check of the interlock and emergency stop requires a restart.



The interlock function is checked by the operator standing up from the seat when the roller is moving very slowly forwards/backwards. (Check in both directions). Hold the steering wheel firmly and brace yourself for a sudden stop. A buzzer goes on and after 4 seconds the engine switches off and the brakes are activated.

If malfunction is detected during emergency stop testing, replace it immediately with a new one.



Check the function of the emergency stop by pressing the emergency stop when the roller is moving slowly forwards/backwards. (Check in both directions). Hold the steering wheel firmly and brace yourself for a sudden stop. The engine switches off and the brakes are activated.



Check the function of the parking brake by activating the parking brake when the roller is moving very slowly forwards/backwards. (Check in both directions). Hold the steering wheel and brace yourself for a sudden stop when the brakes are activated. The engine does not switch off.

Edge cutting (Optional)

The machine must be running to activate the edge cutter/compactor.

With the machine in **Working mode/Edge cutter** (20) (middle LEDs lit) the edge cutter/compactor is controlled up and down with the help of button (3) and button (2) on the control lever.

The edge cutter/compactor can always be moved upwards, irrespective of the position selected on the button **Working mode** (20). Also in **Transport mode** (0 LEDs lit) the edge cutter/compactor can be moved upwards, with button (3).

A bypass valve prevents the hydraulic system being overloaded.

The operator should use the ordinary sprinkler system to avoid asphalt sticking to the edge cutter/compactor, and open the ball valve (5) by the separate sprinkler nozzle on the edge cutter/compactor.

The operator can choose between two tools, the edge cutter or edge compactor. The edge cutter (1) in the figure is shown in the operating position. The edge compactor (1) can easily be replaced with the edge cutter by releasing the bolted joint (3).

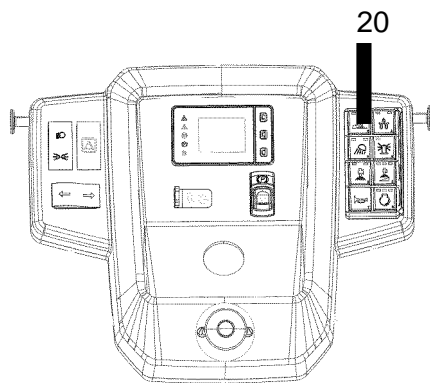

Fig. Instrument panel
20. Edge cutter/compactor, Up/Down

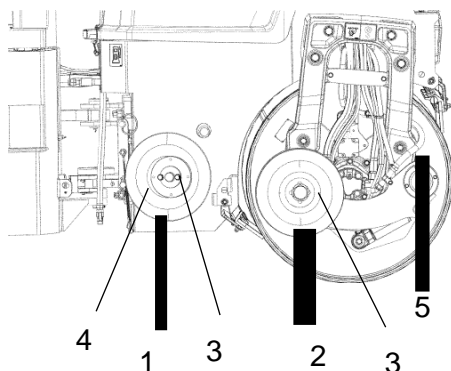

Fig. Changing tools
1. Edge compactor
2. Edge cutter
3. Bolted joints
4. Holder for cutter/compactor wheel
5. Ball valve

Vibration

Manual/Automatic vibration

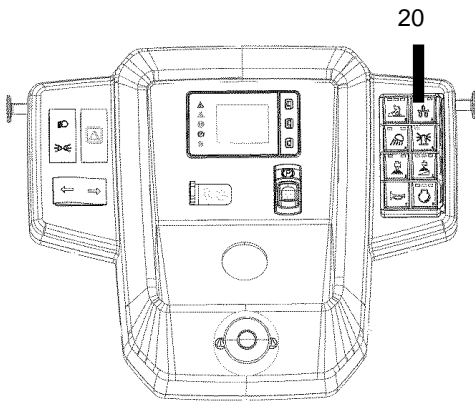

Fig. Instrument panel
20. Switch, Vibration selector

In **Working mode/Vibration** (20) (LED LEFT lit) you can select, manually, which drum is to vibrate with the button on the forward/reverse lever.

For Standard machine:

Button (1) activates vibration on **on both** the drums.

For machines equipped with the accessory - individual vibrations shutoff:

Button (1) activates vibration on **the front** drum.

Button (2) activates vibration on **the rear** drum.

Both buttons activate vibration on **on both** the drums.

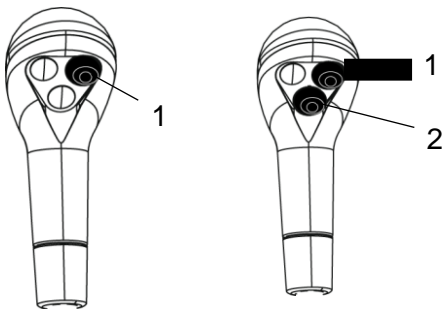

Standard equipped machine

The machine is equipped with options

Fig. Right Forward/Reverse lever

In automatic mode, the vibration is activated when the pre-set speed is reached, provided that one or both drums are selected with the help of the buttons on the control lever.

(See the Display chapter to active).

Vibration is automatically deactivated when the lowest pre-set speed is reached.

Deactivation is performed by pressing one or both of the buttons (1 and 2) again.

**If the machine is in Transport mode and the buttons on the forward/reverse lever are pressed, the Working mode symbol is shown on the display.
The three LEDs on the Working position button flash.**

Braking

Normal braking

Turn off the vibration using the buttons (1) and (2) on the control lever.

Move the forward/reverse lever (6) to the neutral position to stop the roller.

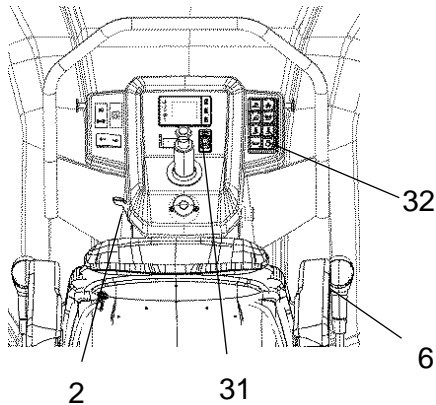

Fig. Controls panel
2. Throttle control (D1703/V2403-M-E3B)
6. Forward/Reverse lever
31. Parking brake
32. Engine speed selector
(no used)



When starting and driving a machine that is cold, remember that the hydraulic fluid is also cold and that braking distances can be longer than normal until the machine reaches the working temperature.



Never leave the operator platform without activating the parking brake (31).

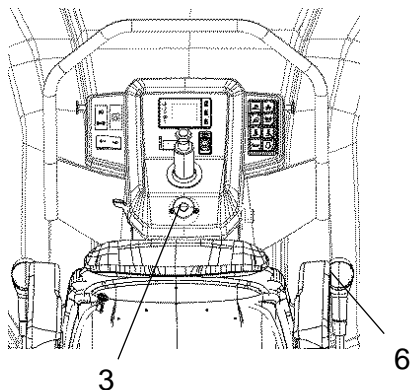

Fig. Control panel
3. Emergency stop
6. Forward/Reverse lever

Emergency braking

Braking is normally activated using the forward/reverse lever (6). The hydrostatic transmission brakes the roller when the lever is moved to the neutral position.

There is a brake on each drum motor that acts a secondary brake when in motion, and as a parking brake when stationary.



To brake in an emergency situation, push in the emergency stop (3), hold the steering wheel firmly and be prepared for a sudden stop. The diesel engine stops.

After emergency braking, reset the forward/reverse lever (6) to neutral position, pull out the emergency stop and activate the parking brake. Restart the engine.

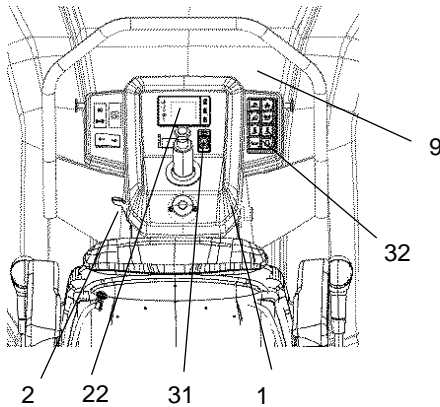

Fig. Instrument panel

- 1. Ignition key**
- 2. Throttle control (D1703/V2403-M-E3B)**
- 9. Instrument cover**
- 22. Panel for warning lamps**
- 31. Parking brake**
- 32. Engine speed selector (no used)**

Switching off

Activate the parking brake (31).

D1703 / V2203-M-E3B

Turn the engine speed control (2) back to idling.

Allow the engine to idle for a few minutes to cool down.

Check instruments and warning lamps to see if any faults are indicated. Switch off all lights and other electrical functions.

Turn the ignition key (1) to the left to the switched off position. At the end of the shift, fold over the instrument cover (9) and lock.

Parking

Chocking the drums



Never disembark from the roller when the diesel engine is running, without first activating the parking brake.



Make sure that the roller is parked in a safe place with respect to other road users. Chock the drums if the roller is parked on sloping ground.



Remember that there is a risk of freezing during the winter. Empty the water tank. Fill antifreeze in the engine's cooling system. See also maintenance instructions.

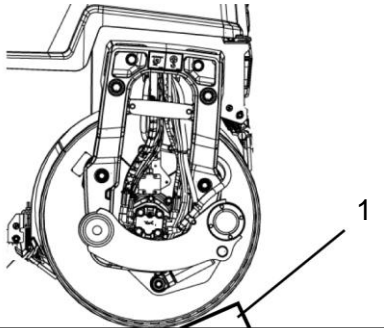

Fig. Drum part
1. Chocks

Battery disconnecter

Before leaving the roller at the end of the shift, switch off the battery disconnecter (1) and remove the key.

This will prevent battery discharging and will also make it difficult for unauthorized persons to start and operate the machine. Lock also the engine cover.

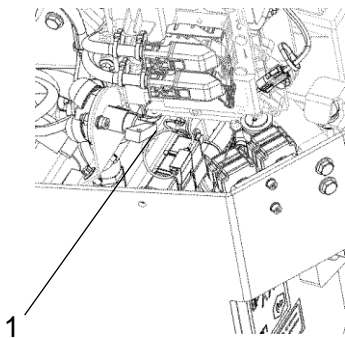

Fig. Battery compartment
1. Battery disconnecter

Long-term parking

 The following instructions should be followed when long term parking (more than one month).

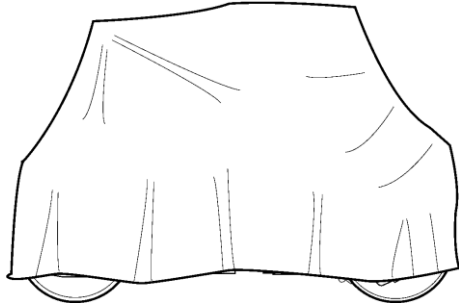

Fig. Roller weather protection

These measures apply when parking for a period of up to 6 months.

Before re-commissioning the roller, the points marked with an asterisk * must be returned to the pre-storage state.

Wash the machine and touch up the paint finish to avoid rusting.

Treat exposed parts with anti-rust agent, lubricate the machine thoroughly and apply grease to unpainted surfaces.

Engine

* Refer to the manufacturer's instructions in the engine manual that is supplied with the roller.

Battery

* Dismantle the battery/batteries from the machine, clean the outside and maintenance charge.

Air cleaner, exhaust pipe

* Cover the air cleaner or its opening with plastic or tape. Also cover the exhaust pipe opening. This is to avoid moisture entering the engine.

Fuel tank

Fill the fuel tank completely full to prevent condensation.

Hydraulic reservoir

Fill the hydraulic reservoir to the uppermost level mark (see under the heading 'Every 10 hours of operation.')

Steering cylinder, hinges, etc.

Lubricate the steering joint bearings and the steering cylinder's two bearings with grease.

Grease the piston rod of the steering cylinder with inhibitor grease.

Grease the hinges on the engine compartment hood and also grease both ends of the forward/reverse control (bright parts).

Watering system

* Empty the water tank and all hoses of water. Empty the filter housing and the water pump. Undo all sprinkler nozzles.

Hoods, tarpaulin

* Lower the instrument cover over the instrument panel.

* Cover the entire roller with a tarpaulin. A gap must be left between the tarpaulin and the ground.

* If possible, store the roller indoors and ideally in a building where the temperature is constant.

Miscellaneous

Lifting

Locking the articulation



Articulation must be locked to prevent inadvertent turning before lifting the roller.

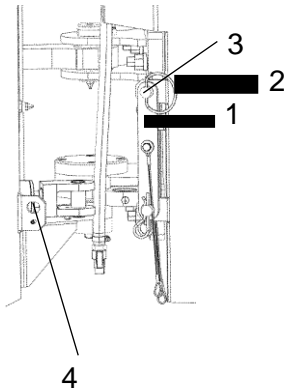

Fig. Articulation in the locked position

- 1. Locking arm**
- 2. Locking pin**
- 3. Locking stud**
- 4. Locking lug**

Turn the steering wheel to the straight ahead position.
Enable the parking brake.

Pull out the locking pin (2) fitted with a wire, and pull up/out the locking dowel (3).

Fold out the locking arm (1) and secure it to the upper locking lug (4) on rear frame.

Fit the locking stub (3) in the holes through the locking arm (1) and locking lug (4) and secure the stud in position with the locking pin (2).

Weight: see the machine plate on the roller

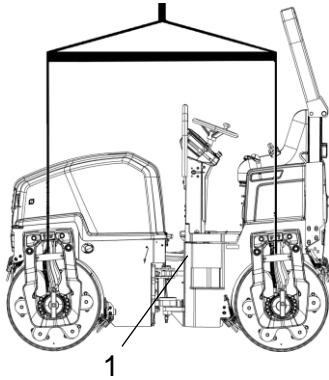

Fig. Four-point lift of the roller
1. Machine plate

Lifting the roller



The maximum weight of the machine (5) can be read on the machine plate (1).



Lifting equipment such as chains, steel wires, straps and lifting hooks must be dimensioned in accordance with the relevant safety regulations for the lifting equipment.



Stand well clear of the hoisted machine! Make sure that the lifting hooks are properly secured.



The machine must not be lifted with chips in the chip spreader.

 Dynapac (China) Compaction & Paving Equipment Co., Ltd. 38, Guanwang Rd, Huqing High Tech Ind. Park, Tianjin, China 301700			
Product Identification Number			
Designation	Type	Rated Power kW	Max axle load front/rear kg
Gross machinery mass kg	Operating mass kg	Max ballast kg	Date of Mfg kg
Designed by Dynapac in Sweden, assembled in China 4812 1911 12			

5

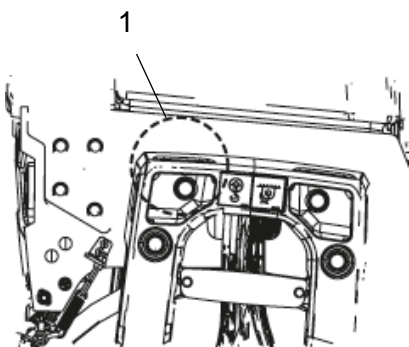

Fig. Four-point lift of the roller - Rear forks
1. Location of the lifting hook

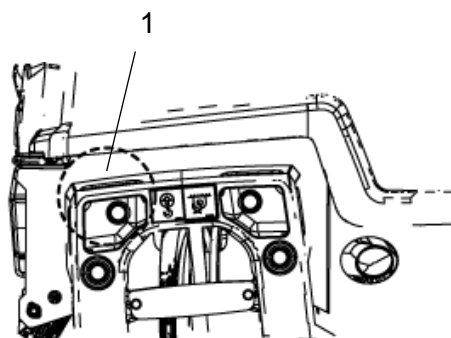

Fig. Four-point lift of the roller - Front forks
1. Location of the lifting hook

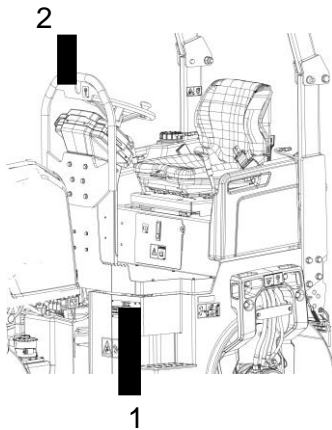

Fig. Single -point lift of the roller
1. Machine plate
2. Location of the lifting hook

The maximum weight of the machine (5) can be read on the machine plate (1).

Lifting the roller with a single -point lift (Optional) (CC11200VI only)



Lifting equipment such as chains, steel wires, straps and lifting hooks must be dimensioned in accordance with the relevant safety regulations for the lifting equipment.



Stand well clear of the hoisted machine! Make sure that the lifting hooks are properly secured.



The machine must not be lifted from the ROPS, (Roll Over Protective Structure) if the machine is not equipped with a single-point lift.



The machine must not be lifted from the single-point lift if the machine is equipped with a chip spreader.

 Dynapac (China) Compaction & Paving Equipment Co., Ltd. 38, Guanzhong Rd, Wuqing High Tech Ind. Park, Tianjin, China 301700			
Product Identification Number			
Designation	Type	Rated Power	Max axle load front/rear
		kW	kg
Gross machinery mass	Operating mass	Max ballast	Date of Mfg
kg	kg	kg	
Designed by Dynapac in Sweden, assembled in China 482 123 12			

5

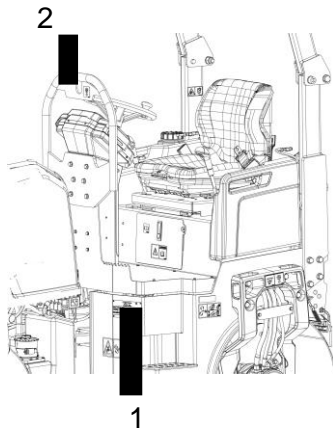



Fig. Single -point lift of the roller
 1. Machine plate
 2. Location of the lifting hook

 Dynapac (China) Compaction & Paving Equipment Co., Ltd. 38, Guowang Rd, Wuziqing High Tech Ind Park, Tianjin, China 301700			
Product Identification Number			
Designation	Type	Rated Power	Max axle load front/rear
		kW	kg
Gross machinery mass	Operating mass	Max balast	Date of Mfg
kg	kg	kg	kg
Designed by Dynapac in Sweden, assembled in China 482 231 12			

5

Fig. Machine plate 5. Maximum weight

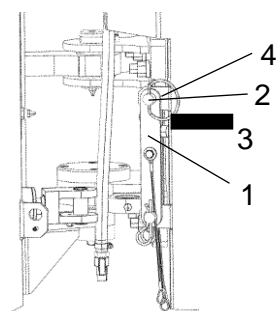

Fig. Articulation in the open position
 1. Locking arm
 2. Locking pin
 3. Locking stud
 4. Locking lug

Lifting the roller with a single -point lift (Optional) (CC1200VI only)



The maximum weight of the machine (5) can be read on the machine plate (1).



Lifting equipment such as chains, steel wires, straps and lifting hooks must be dimensioned in accordance with the relevant safety regulations for the lifting equipment.



Stand well clear of the hoisted machine! Make sure that the lifting hooks are properly secured.



The machine must not be lifted from the ROPS, (Roll Over Protective Structure) if the machine is not equipped with a single-point lift.



The machine must not be lifted from the single-point lift if the machine is equipped with a chip spreader.

Unlocking the articulation



Remember to unlock the articulation before operating.

Fold the locking arm (1) back and secure it in the locking lug (4) with the stud (3). Insert the locking pin (2) fitted with a wire, to secure the stud (3). The locking lug (4) is located on the front frame.

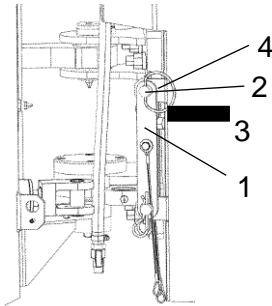

Fig. Articulation in the open position

1. Locking arm
2. Locking pin
3. Locking stud
4. Locking lug

Unlocking the articulation



Remember to unlock the articulation before operating.

Fold the locking arm (3) back and secure it in the locking lug (4) with the stud (3). Insert the locking pin (2) fitted with a wire, to secure the stud (3). The locking lug (4) is located on the front frame.

Towing/Recovering

The roller can be moved up to 300 meters (330 yards) using the instructions below.

Release the brakes



Activate the parking brake, and stop the engine. Block the drum with a chock to prevent movement; the roller can start rolling when the brakes are released.



The disc brake in each drive motor must be disengaged mechanically, according to below following instructions, before the roller can be towed.

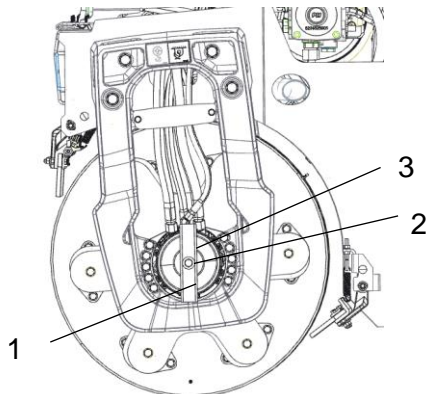

Fig. Left side of drum

1. Brake tool
2. Fastening screw
3. Disengagement nut

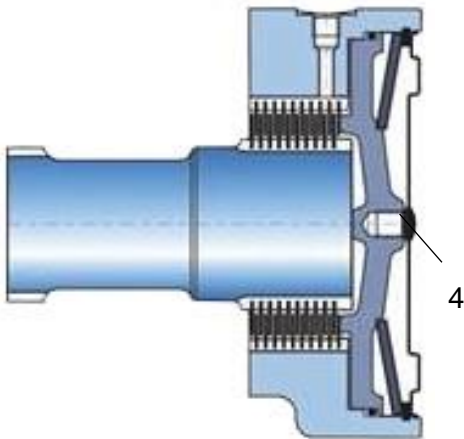

Fig. Brake housing
4. Center plug

Remove the center plug (4) using a screwdriver.

Screw off the brake tool (1) from its threaded fixing hole. Then fix the brake tool (1) in the center hole by tightening the screw (2) until it bottoms in the hole. Tighten the nut (3) against the brake tool until it stops, indicating that the brakes is now disengaged.

Tightening torque:

CC1200/C VI: 42 Nm (31 lb.ft)

CC1300/C VI - CC1400/C VI: 107 Nm (79 lb.ft)

Disengaging the brakes

Screw out the nut again after towing. This returns the brakes to their normal mode. Screw off the brake tool and fit it back into its fixing holes. Refit the center plug (4) to counteract the information of rust inside the threaded hole.

Towing the roller



Fig. Towing



The roller must be counter-braked during towing/recovery. Always use a towbar. There is no braking capacity on the roller now.



The roller must be towed slowly, max. 3 kph (2 mph) and only towed short distances, max. 300 m (1000 ft).

When towing/retrieving a machine, the towing device must be connected to both lifting holes. The pulling force shall act longitudinally on the machine as shown in the figure.

Maximum total pulling force:

- CC1200VI 39 kN (9.767 lbf)
- CC1300 VI / CC1400 VI 63 kN (14.163 lbf)



Reverse the towing preparations.

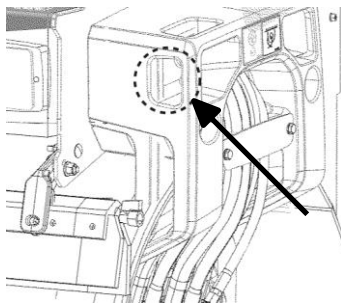

Fig. Bracket, towing - front

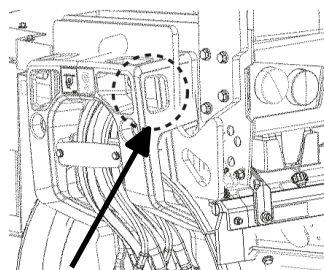

Fig. Bracket, towing - rear

Short distance towing with switched off engine

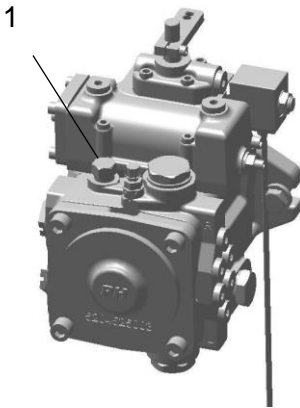

Fig. Propulsion pump (CC1200/C VI)
1. Bypass screw



Check the drums to prevent the roller from moving.

Open the hood and make sure that the propulsion pump is accessible.

There is a bypass screw (1) located on the pump that must be unscrewed counterclockwise (max two turns), to put the drive system (ports A and B) in bypass mode.

This function enables a machine to be moved without the drive shaft on the propulsion pump rotating.

Turn the bypass screw (1) clockwise to reset.

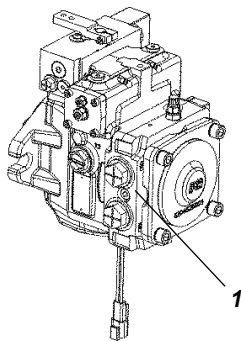

Fig. Propulsion pump (CC1300/C VI - CC1400/C VI)
1. By-pass screw

Transport

Tie-down and secure the machine according to the Cargo Securing Certificate for the specific machine if this is available and applicable.

If not, tie down and secure the machine according to the cargo securing rules that are valid for the country where the transport takes place.



Never lash over the machine's articulated joint, nor over the machine's operator platform.

Before securing the machine ensure that :

- the parking brake is applied and in good working condition
- the articulated joint is in closed position
- the machine is centered laterally on the platform
- the lashings are in good condition and fulfills the corresponding rules for transport securing.

Securing CC1200/C VI for loading

Securing of a double vibratory roller of model CC1200/C VI from Dynapac loaded on a trailer for transport on road and in the Baltic / North sea (sea area A/B).

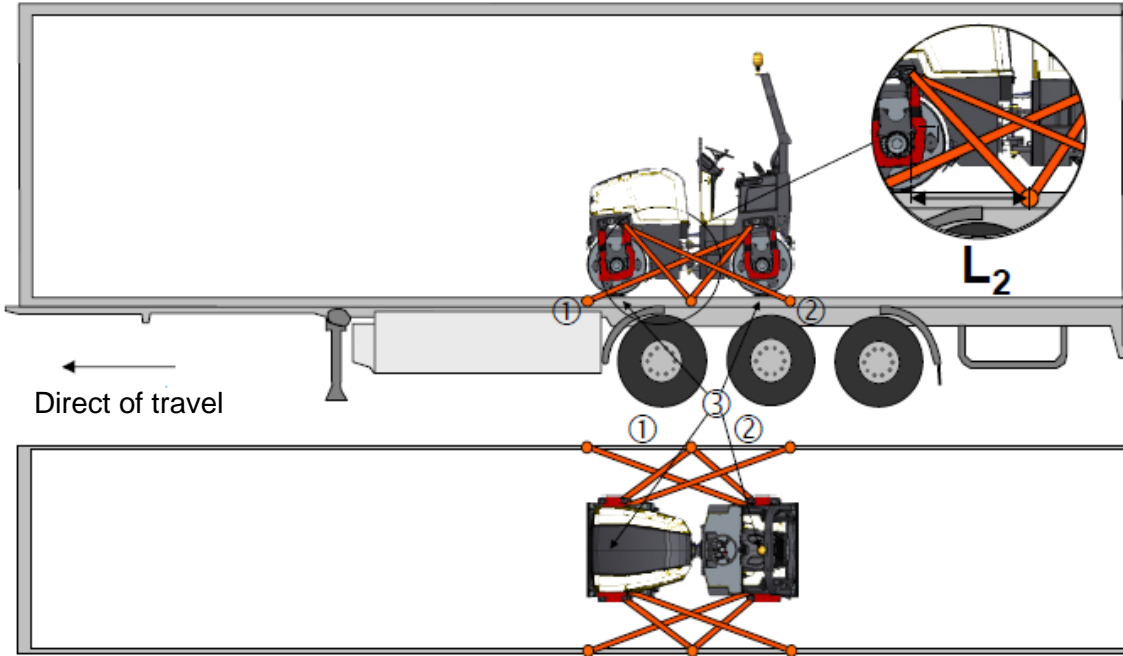

1 - 2 = double lashings, i.e. one lashing with two parts secured to two different lashing mounts on the trailer, symmetrically located on the right and left sides.

3 = rubber friction pads

The lashings' permitted distance interval in meters		
(1 - 2: Double lashings, LC at least 1.6 tonnes (1600 daN))		
Double L ₁	Double L ₂	
0.3 - 2.5	0.1 - 2.5	

$L_1 - L_2$ are the longitudinal distances between the lashing points on the roller and lashing points on the platform.

Load carrier

Ensure that:

- When loaded, the vibratory roller is centered laterally on the platform (± 5 cm).
- The parking brake is applied and in good working condition, and the articulated joint lock is closed.

- The drum is placed on a rubber liner, so that the static friction between the surfaces is at least 0.6.
- The contact surfaces must be clean, wet or dry, and free from frost, ice and snow. If there is a risk of frost, ice and/or snow the platform has to be salted.
- The lashing mounts on the load carrier have LC/MSL at least 2 tonnes.

Lashings

Ensure that:

- The lashings comprise a lashing strap or chain with a permitted load (LC/MSL) of at least 1.6 tonnes (1,600 daN) and the lashings are well pre-tensioned during the entire transport.
- Each of lashings 1-2 is either a double or two single lashings. A double lashing runs in a sling through a lashing point or around a machine part and down into two different mounts on the platform.
- Lashings in the same direction are placed in different lashing mounts on the trailer. Lashings that are pulled in opposite directions may be placed in the same lashing mount, however.
- The lashings are as short as possible.
- The lashing hooks must not lose grip if the lashings become slack.
- The lashings are protected against sharp edges and corners.
- The lashings are located symmetrically in pairs on the right and left sides.

Securing CC1200/C VI for loading (Side along the trailer)

Securing of two CC1200/C VI vibratory rollers from Dynapac loaded side by side along a trailer for transport on road and in Baltic sea (Sea area A).

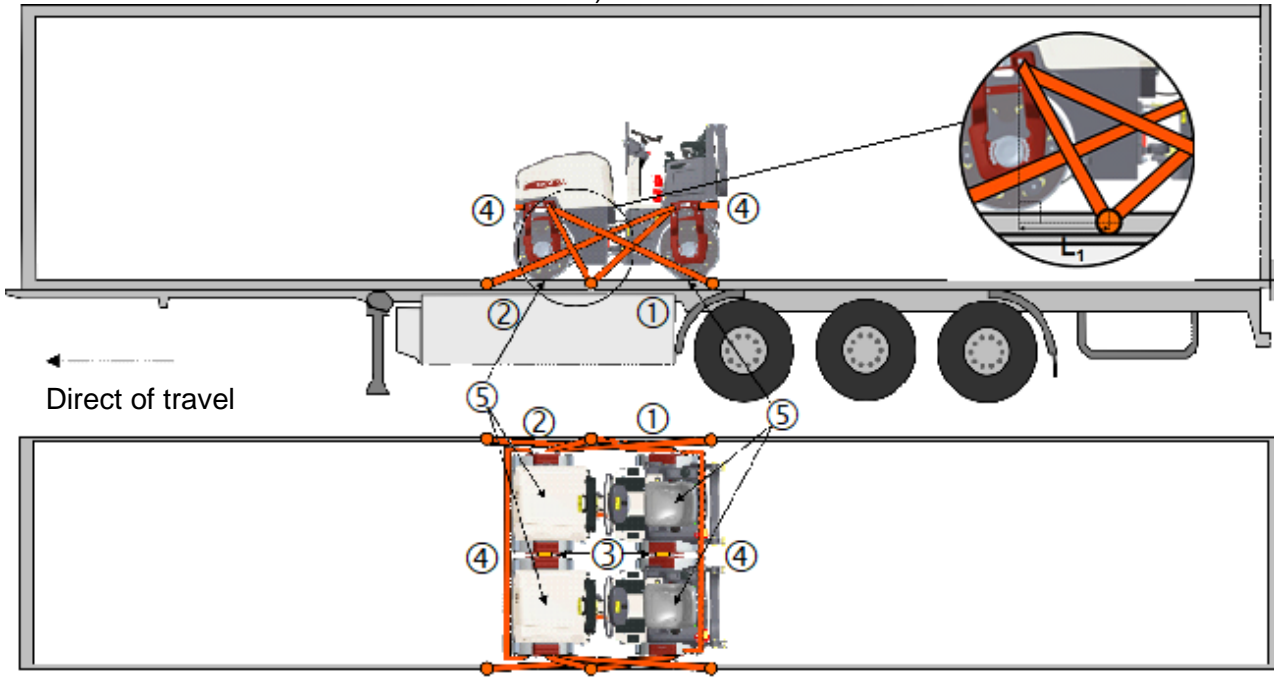

- 1 - 2 = double lashings, i.e. one lashing with two parts secured to two different lashing mounts on the trailer. Symmetrically located on the right and left sides.
- 3 = wooden battens used as spacers between the rollers, kept in place by sufficient means
- 4 = the two rollers are tied together to one unit.
- 5 = rubber friction pads

The lashings' permitted distance interval in meters		
(1 - 2: Double lashings, LC at least 1.6 tonnes (1600 daN))		
Double L_1	Double L_2	
0.4 - 2.5	0.1 - 2.5	

L_1 and L_2 are the longitudinal distances between the lashing points on the roller and lashing points on the platform.

Load carrier

Ensure that:

- When loaded, the vibratory roller is centered laterally on the platform (± 5 cm).
- The parking brake is applied and in good working condition, and the articulated joint lock is closed.
- The drum is placed on a rubber liner, so that the static friction between the surfaces is at least 0.6.
- The contact surfaces must be clean, wet or dry, and free from frost, ice and snow. If there is a risk of frost, ice and/or snow the platform has to be salted.
- The lashing mounts on the load carrier have LC/MSL at least 2 tonnes.

Lashings

Ensure that:

- The lashings comprise a lashing strap or chain with a permitted load (LC/MSL) of at least 1.6 tonnes (1,600 daN) and the lashings are well pre-tensioned during the entire transport.
- Each of lashings 1-3 is either a double or two single lashings. A double lashing runs in a sling through a lashing point or around a machine part and down into two different mounts on the platform.
- Lashings in the same direction are placed in different lashing mounts on the trailer. Lashings that are pulled in opposite directions may be placed in the same lashing mount, however.
- Lashing 4 ties the two rollers together to one unit. The lashing is drawn from drum to drum or from lashing eye to lashing eye on the front part as well as the rear part of the rollers.
- The lashings are as short as possible.
- The lashing hooks must not lose grip if the lashings become slack.
- The lashings are protected against sharp edges and corners.
- The lashings are located symmetrically in pairs on the right and left sides.

Securing CC1200/C VI for loading (Side along the trailer)

Securing of two CC1200/C VI vibratory rollers from Dynapac loaded side by side along a trailer for transport on road and in North sea (Sea area B).

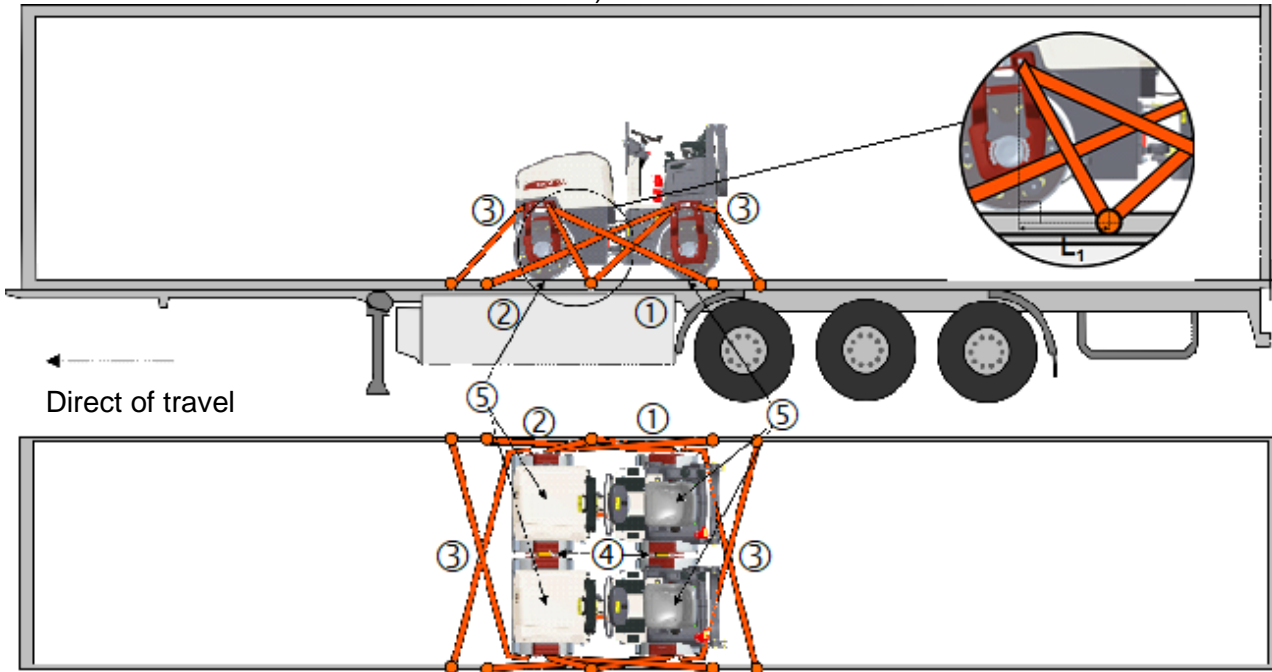

- 1 - 2 = double lashings, i.e. one lashing with two parts secured to two different lashing mounts on the trailer. Symmetrically located on the right and left sides.
- 3 = single cross lashings
- 4 = wooden battens used as spacers between the rollers, kept in place by sufficient means
- 5 = rubber friction pads

The lashings' permitted distance interval in meters		
(1 - 2: Double lashings, LC at least 1.6 tonnes (1600 daN))		
Double L ₁	Double L ₂	Double L ₃
0.4 - 2.5	0.1 - 2.5	0.1 - 2.0

L₁ - L₃ are the longitudinal distances between the lashing points on the roller and lashing points on the platform.

Load carrier

Ensure that:

- When loaded, the vibratory roller is centered laterally on the platform (± 5 cm).
- The parking brake is applied and in good working condition, and the articulated joint lock is closed.
- The drum is placed on a rubber liner, so that the static friction between the surfaces is at least 0.6.
- The contact surfaces must be clean, wet or dry, and free from frost, ice and snow. If there is a risk of frost, ice and/or snow the platform has to be salted.
- The lashing mounts on the load carrier have LC/MSL at least 2 tonnes.

Lashings

Ensure that:

- The lashings comprise a lashing strap or chain with a permitted load (LC/MSL) of at least 1.6 tonnes (1,600 daN) and the lashings are well pre-tensioned during the entire transport.
- Each of lashings 1-2 is either a double or two single lashings. A double lashing runs in a sling through a lashing point or around a machine part and down into two different mounts on the platform. Lashings 3 are single lashings.
- Lashings in the same direction are placed in different lashing mounts on the trailer. Lashings that are pulled in opposite directions may be placed in the same lashing mount, however.
- The lashings are as short as possible.
- The lashing hooks must not lose grip if the lashings become slack.
- The lashings are protected against sharp edges and corners.
- The lashings are located symmetrically in pairs on the right and left sides.

Securing CC1200/C VI for loading (Side across the trailer)

Securing of two CC1200/C VI vibratory rollers from Dynapac loaded side by side across a trailer for transport on road and in Baltic sea /North sea (Sea area A/B).@@

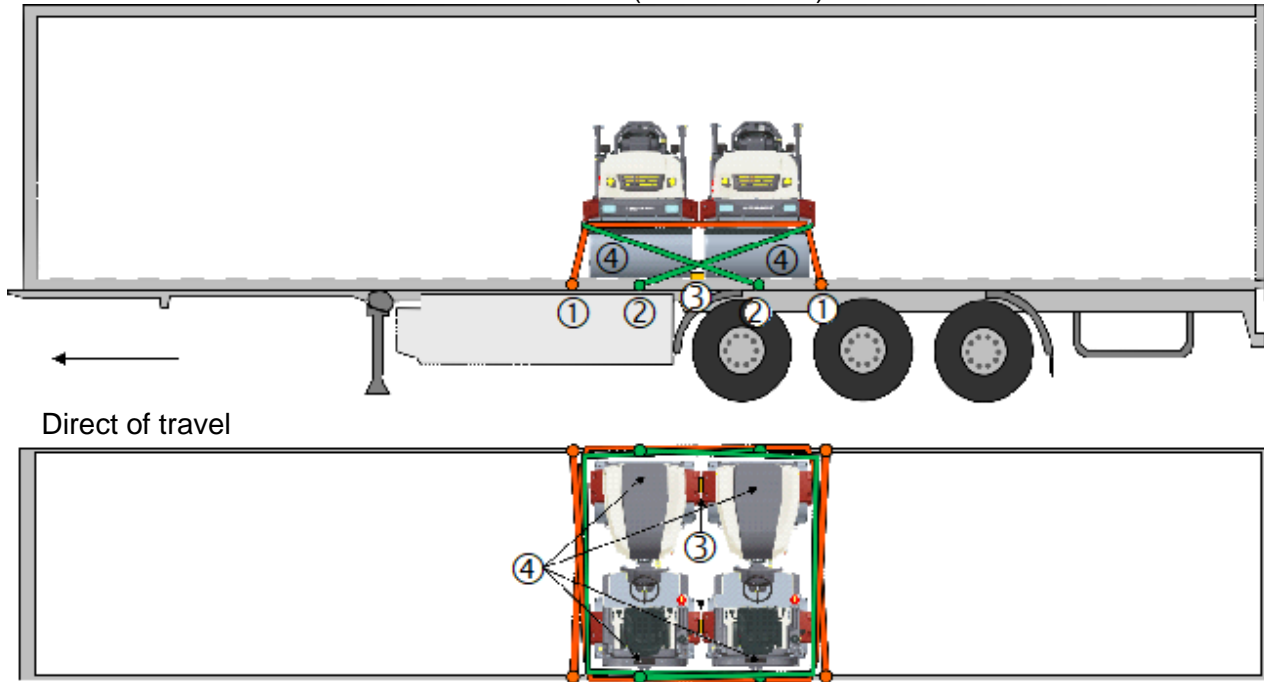

- 1 = two spring lashings (orange), one directed to the right and one to the left, which are attached on the platform as close to the rollers as possible. LC at least 1.6 tonnes (1600 daN)
- 2 = two spring lashings (green); one directed forward and one backward. LC at least 1.6 ton (1600 daN)
- 3 = wooden battens used as spacers between the rollers, kept in place by sufficient means
- 4 = rubber friction pads

Load carrier

Ensure that:

- When loaded, the vibratory roller is centered laterally on the platform (± 5 cm).
- The parking brake is applied and in good working condition, and the articulated joint lock is closed.
- The drum is placed on a rubber liner, so that the static friction between the surfaces is at least 0.6.
- The contact surfaces must be clean, wet or dry, and free from frost, ice and snow. If there is a risk of frost, ice and/or snow the platform has to be salted.
- The lashing mounts on the load carrier have LC/MSL at least 2 tonnes.

Lashings

Ensure that:

- The lashings comprise a lashing strap or chain with a permitted load (LC/MSL) of at least 1.6 tonnes (1,600 daN) and the lashings are well pre-tensioned during the entire transport.
- The lashings are placed in different lashing points in the trailer. Lashings drawn in opposite directions are allowed to be attached to the same lashing point.
- Lashings securing the rollers sideways; the hooks are placed as close to the rollers as possible on the platform to not steal space for any other cargo.
- The lashings are kept as short as possible.
- The lashing hooks must not lose grip if the lashings become slack.
- The lashings are protected against sharp edges and corners.
- The lashings are located symmetrically in pairs on the right and left sides.

Securing CC1300/C VI - CC1400/C VI for loading

Securing of a double vibratory roller of model CC1300/C VI - CC1400/C VI from Dynapac loaded on a trailer for transport on road and in the Baltic / North sea (sea area A/B).

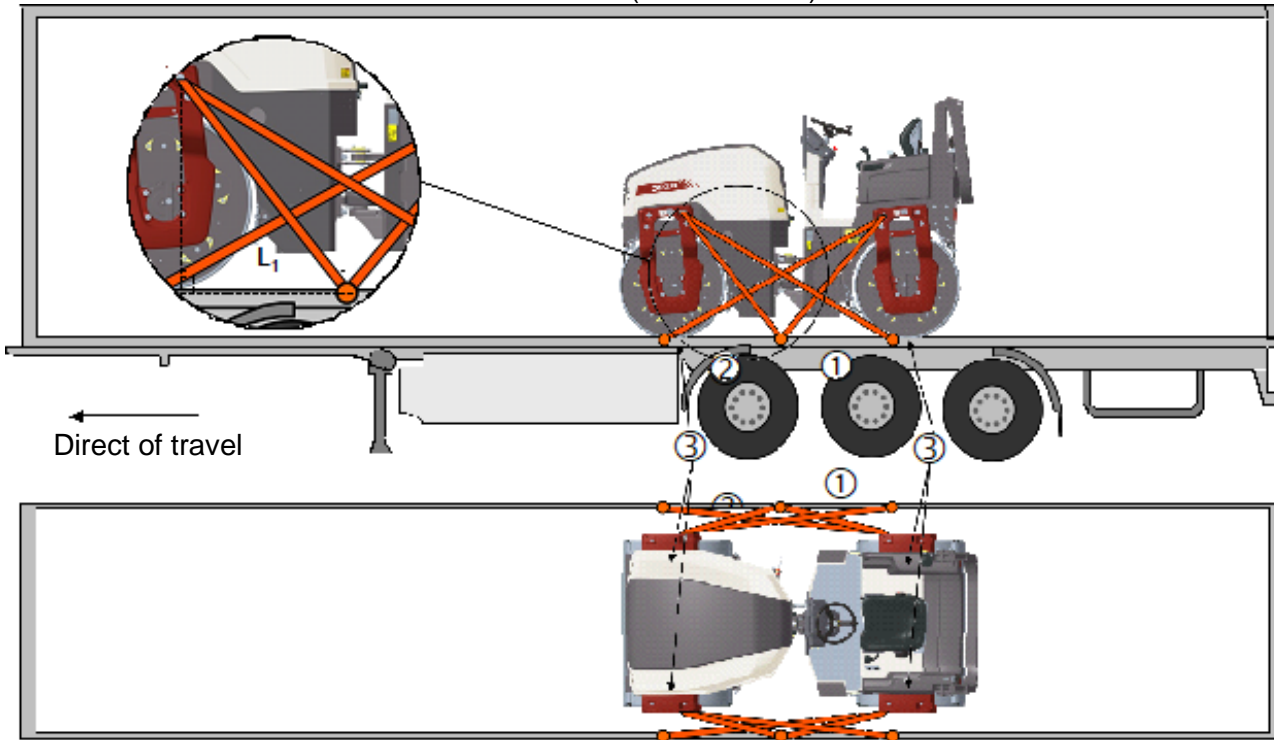

- 1 - 2 = double lashings, i.e. one lashing with two parts secured to two different lashing mounts on the trailer, symmetrically located on the right and left sides.
- 3 = rubber

The lashings' permitted distance interval in meters		
(1 - 2: Double lashings, LC at least 1.6 tonnes (1600 daN))		
Double L ₁	Double L ₂	
0.5 - 2.5	0.2 - 2.5	

L₁ and L₂ are the longitudinal distances between the lashing points on the roller and lashing points on the platform.

Load carrier

Ensure that:

- When loaded, the vibratory roller is centered laterally on the platform (± 5 cm).
- The parking brake is applied and in good working condition, and the articulated joint lock is closed.

- The drum is placed on a rubber liner, so that the static friction between the surfaces is at least 0.6.
- The contact surfaces must be clean, wet or dry, and free from frost, ice and snow. If there is a risk of frost, ice and/or snow the platform has to be salted.
- The lashing mounts on the load carrier have LC/MSL at least 2 tonnes.

Lashings

Ensure that:

- The lashings comprise a lashing strap or chain with a permitted load (LC/MSL) of at least 1.6 tonnes (1,600 daN) and the lashings are well pre-tensioned during the entire transport.
- Each of lashings 1-2 is either a double or two single lashings. A double lashing runs in a sling through a lashing point or around a machine part and down into two different mounts on the platform.
- Lashings in the same direction are placed in different lashing mounts on the trailer. Lashings that are pulled in opposite directions may be placed in the same lashing mount, however.
- The lashings are kept as short as possible.
- The lashing hooks must not lose grip if the lashings become slack.
- The lashings are protected against sharp edges and corners.
- The lashings are located symmetrically in pairs on the right and left sides.

Foldable ROPS

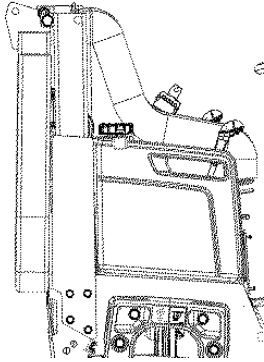

Fig. Retractable ROPS

The machine is equipped with foldable ROPS



Risk of crush injury when raising and lowering ROPS.



Always make sure the ROPS is locked in raised position before operation

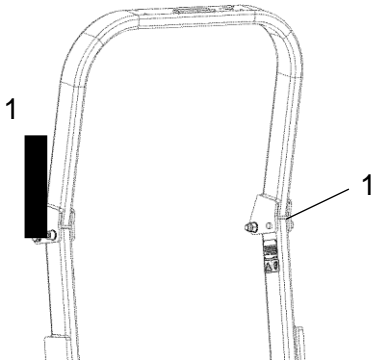

Fig. ROPS locking device
1. Bolt

When retract the ROPS, loosen the screw (1) and pull it out. Do the same on both sides of the ROPS.



After lowering the ROPS, replace the screw in its position

To lift the ROPS proceed in the reserve order.



Always make sure the ROPS is locked in raised position before operation.

Grease the screw (1) periodically using water resistant grease.

Operating instructions - Summary



1. Follow the **SAFETY INSTRUCTIONS** specified in the **Safety Manual**.
2. Make sure that all instructions in the **MAINTENANCE** section are followed.
3. Turn the master switch to the **ON** position.
4. Set the emergency stop in the pulled out position.
5. Move the forward/reverse lever to the **NEUTRAL** position.
6. Set the engine speed control to **MEDIUM**. (**D1703 / V2403-M**).
7. Start the engine and allow it to warm up.
8. Set the engine speed control to the operating position.



9. **Drive the roller. Operate the forward/reverse lever with care.**



10. **Check the brakes, drive slowly. Remember that the braking distance will be longer if the hydraulic oil is cold.**
11. Use vibration only when the roller is in motion.
12. Check that the drums are thoroughly watered when watering is required.



13. **IN AN EMERGENCY:**
 - Press the **EMERGENCY STOP**
 - Hold the steering wheel firmly.
 - Brace yourself for a sudden stop. The engine stops.
14. Parking: - Stop the engine and chock the drums.
15. When lifting: - Refer to the relevant section in the Instruction Manual.
16. When towing: - Refer to the relevant section in the Instruction Manual.
17. When transporting: - Refer to the relevant section in the Instruction Manual.
18. When recovering - Refer to the relevant section in the Instruction Manual.

Preventive maintenance

Complete maintenance is necessary for the machine to function satisfactorily and at the lowest possible cost.

The Maintenance section includes the periodic maintenance that must be carried out on the machine.

The recommended maintenance intervals assume that the machine is used in a normal environment and working conditions.

Acceptance and delivery inspection

The machine is tested and adjusted before it leaves the factory.

On arrival, before delivery to the customer, delivery inspection must be conducted as per the check list in the warranty document.

Any transport damage must be reported immediately to the transport company, as this is not covered by the product warranty.

Warranty

The warranty is only valid if the stipulated delivery inspection and the separate service inspection have been completed as per the warranty document, and when the machine has been registered for starting under the warranty.

The warranty is not valid if damage has been caused by inadequate service, incorrect use of the machine, the use of lubricants and hydraulic fluids other than those specified in the manual, or if any other adjustments have been made without the requisite authorization.

CALIFORNIA

Proposition 65

Decal and location of decal shown in section
Machine description.

WARNING: Breathing diesel engine exhaust exposes you to chemicals known to the State of California to cause cancer and birth defects or other reproductive harm.

- Always start and operate the engine in a well-ventilated area.
- If in an enclosed area, vent the exhaust to the outside.
- Do not modify or tamper with the exhaust system.
- Do not idle the engine except as necessary.

For more information go to www.P65warnings.ca.gov/diesel.

Maintenance - Lubricants and symbols



Always use high-quality lubricants and the amounts recommended. Too much grease or oil can cause overheating, resulting in rapid wear.

Fluid volumes

Hydraulic tank	40 liters	42.3 qts
----------------	-----------	----------

Diesel engine

CC1200/C VI

- D1703-M-DI-E4B (Tier 4f / CS IV)	7 liters	7.4 qts
------------------------------------	----------	---------

- D1703-M-IDI-E3 (T3)	7 liters	7.4 qts
-----------------------	----------	---------

CC1300/C VI - CC1400/C VI

- V2403-M-DI-E3B(R96 & CS IV)	9.5 liters	10 qts
-------------------------------	------------	--------

Coolant

- D1703-M-DI-E4B (Tier 4f / CS IV)	6 liters	6.3 qts
------------------------------------	----------	---------

- D1703-M-IDI-E3 (T3)	6 liters	6.3 qts
-----------------------	----------	---------









- V2403-M-DI-E3B(R96 & CS IV)	8.7 liters	9.2 qts
-------------------------------	------------	---------

Drum

- CC1200/C VI	7 liters	7.4 qts
---------------	----------	---------

- CC1300/C VI	8 liters	8.4 qts
---------------	----------	---------













- CC1400/C VI	9 liters	9.5 qts
---------------	----------	---------

	ENGINE OIL	Air temperature -15°C - +50°C (5°F-122°F)	Dynapac Engine Oil 200	P/N DYNPAPC550(4L) (Stage IIIA/T3) P/N 4812310086(4L) (T4f/R96/CS IV)
	HYDRAULIC FLUID	Air temperature -15°C - +50°C (5°F-104°F)		P/N 4812313760(18L)
	BIOLOGICAL HYDRAULIC FLUID, PANOLIN	Air temperature over +50°C (104°F)	Shell Tellus S2 V100	
	DRUM OIL	When it leaves the factory, the machine may be filled with biologically degradable fluid. The same type of fluid must be used when changing or topping up.	PANOLIN HLP Synth 46 (www.panolin.com)	
	GREASE	Air temp. -15°C - +40°C (5°F-104°F)	Shell Spirax AX 85W/140, API GL-5	P/N DYNAPAC100 (4L)
	FUEL	Air temperature 0°C - over +40°C (32°F- over 104°F)		Dynapac Roller Grease P/N 4812030096 (0.4 kg)
	COOLANT	See engine manual.	-	-
	COOLANT	Anti-freeze protection down to about -37°C (-34.6°F)	Dynapac Coolant 100 (mixed 50/50 with water)	P/N 4812161854 (20 liter)



Other fuel and lubricants are required when operating in areas with extremely high or extremely low ambient temperatures. See the 'Special instructions' chapter, or consult Dynapac.

Maintenance symbols

	Engine, oil level		Air filter
	Engine, oil filter		Battery
	Hydraulic reservoir, level		Sprinkler
	Hydraulic fluid, filter		Sprinkler water
	Drum, oil level		Recycling
	Lubricating oil		Fuel filter

Maintenance - Maintenance schedule

Service and maintenance points

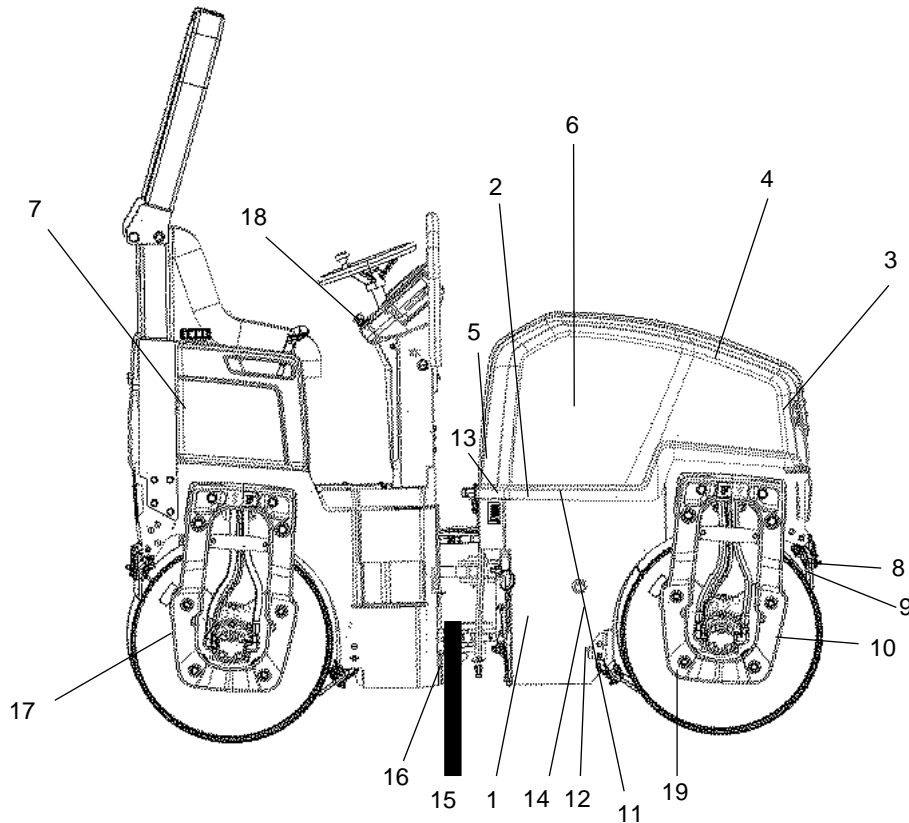



Fig. Service and maintenance points

- | | | |
|------------------|---|---------------------------------|
| 1. Fuel tank | 8. Sprinkler system | 15. Steering joint |
| 2. Refueling | 9. Scrapers | 16. Steering cylinder, bearings |
| 3. Cooler | 10. Shock absorbers and attachment screws | 17. Filler/Level plug, Drum |
| 4. Air cleaner | 11. Hydraulic fluid refilling | 18. Emergency stop |
| 5. Battery | 12. Hydraulic fluid tank | 19. Edge cutter |
| 6. Diesel engine | 13. Hydraulic fluid filter | |
| 7. Water tank | 14. Hydraulic fluid level glass | |

General

Periodic maintenance should be carried out after the number of hours specified. Use the daily, weekly etc. periods where number of hours cannot be used.

 Remove all dirt before filling, when checking oils and fuel and when lubricating using oil or grease.

 The manufacturer's instructions found in the engine manual also apply.
Specific maintenance and checks on diesel engines must be carried out by the engine supplier's certified personnel.

Every 10 hours of operation (Daily)

Refer to the contents to find the page number of the sections referred to !

Pos. in fig	Action	Comment
	Before starting up for the first time on that day	
3	Clean the outside of the cooler package	In dusty conditions when necessary
3	Check coolant level	
6	Check the engine oil level	Refer to the engine manual
14	Check the hydraulic reservoir level	
3	Check for free circulation of cooling air	
2	Fill the fuel tank	
7	Fill the water tank	
8	Check the sprinkler system/Drum	
9	Check the scraper setting/Drum	
9	Check the spring loaded scrapers	Optional
	Test the brakes	

After the FIRST 50 hours of operation

See Contents to find the page number of the sections referred to!

Pos. in fig	Action	Comment
6	Change the engine oil and oil filter	Refer to the engine manual
13	Change the hydraulic fluid filter	
10	Check bolted joints	

Every 50 hours of operation (Weekly)

See Contents to find the page number of the sections referred to!

Pos. in fig	Action	Comment
4	Check indicator for air cleaner Check that the air hoses are in good condition and that the connections are tight	
15, 16	Grease the steering joint and the steering cylinder brackets	
	Check the fuel pipe and hose clamps	
	Drain the fuel prefilter/water separator	Only Tier 4f / CS IV

Every 250 / 750 / 1250 / 1750 hours of operation

See Contents to find the page number of the sections referred to!

Pos. in fig	Action	Comment
5	Check the battery condition	
6	Change the engine oil and oil filter	Refer to the engine manual
6	Cleaning the air filter	
6	Checking belts/belt tension	
3	Checking cooler hoses and hose clamps	
	Checking air intake hoses and hose clamps	

Every 500 hours of operation

See Contents to find the page number of the sections referred to!

Pos. in fig	Action	Comment
5	Check the condition of the battery	
6	Change engine oil and oil filter	Refer to the engine manual
17	Check the oil level in the drum/drums	
10	Check rubber elements and bolted joints	
11	Check the hydraulic reservoir cover/breather	
15, 16	Lubricate the articulated joint and the steering cylinder's bearings	
3	Check coolant freezing point	Change the coolant every other year
4	Replace the air filter (main filter)	
6	Change the engine's fuel filter	Refer to the engine manual
6	Replacing the diesel engine's fuel prefilter/water separator	Refer to the engine manual
3	Checking cooler hoses and hose clamps	
	Checking air intake hoses and hose clamps	
1	Clean the fuel tank	
3	Clean the cooler package	
6	Replacing the diesel engine's V-belt	

Every 1000 hours of operation

See Contents to find the page number of the sections referred to!

Pos. in fig	Action	Comment
5	Check the condition of the battery	
6	Change engine oil and oil filter	Refer to the engine manual
17	Check the oil level in the drum/drums	
10	Check the rubber elements and bolted joints	
11	Check the hydraulic reservoir cover/breather	
15, 16	Lubricate the articulated joint and the steering cylinder's bearings	
3	Check the freezing point of the coolant	Change every other year
4	Replace the air filters (main and backup filter)	or annually
6	Change the engine's fuel filter	Refer to the engine manual
6	Replace diesel engine's fuel prefilter / water separator	Refer to the engine manual
3	Check the cooler hoses and hose clamps	
1	Clean the fuel tank	
3	Clean the cooler package	
6	Check engine's valve clearances	Contact your local Kubota representative
	Checking air intake hoses and hose clamps	
	Change hydraulic fluid filter	
6	Replacing the diesel engine's V-belt	Refer to the engine manual

Every 2000 hours of operation

See Contents to find the page numbers of the sections referred to!

Pos. in fig	Action	Comment
5	Check the battery condition	
6	Change the engine oil and oil filter	Refer to the engine manual
10	Check rubber elements and bolted joints	
11	Check the hydraulic reservoir cover/breather	
15, 16	Lubricate the articulated joint and the steering cylinder's bearings	
3	Check coolant freezing point	Change the coolant every other year
4	Replace the air filters (main and backup filter)	
13	Change hydraulic fluid filter	
6	Change the engine's fuel filter	Refer to the engine manual
6	Replacing the diesel engine's fuel prefilter/water separator	Refer to the engine manual
1	Drain and clean the fuel tank	
3	Clean the cooler package	
7	Drain and clean the water tank	
6	Check the engine valve clearances	Contact your local Kubota representative
12	Change the hydraulic fluid	
18, 17	Change/Check the oil in the drum/drums	
15	Check the condition of the articulation	
	Lubricate the edge cutter	
6	Replace the V-belt on the engine	

Every 3000 hours of operation

See Contents to find the page numbers of the sections referred to!

Pos. in fig	Action	Comment
5	Check the battery condition	
6	Change the engine oil and oil filter	Refer to the engine manual
17	Check the oil level in the drum/drums	
10	Check rubber elements and bolted joints	
11	Check the hydraulic reservoir cover/breather	
15, 16	Lubricate the articulated joint and the steering cylinder's bearings	
3	Check coolant freezing point	Change the coolant every other year
4	Replace the air filters (main and backup filter)	
13	Change the hydraulic fluid filter	
6	Change the engine's fuel filter	Refer to the engine manual
6	Replace diesel engine's fuel prefilter / water separator	Refer to the engine manual
3	Checking cooler hoses and hose clamps	
1	Clean the fuel tank	
3	Clean the cooler package	
6	Check the engine valve clearances	Contact your local Kubota representative
7	Drain and clean the water tank	
12	Change the hydraulic fluid	
	Clean the air and fuel filters	
	Checking air intake hoses and hose clamps	
	Check injection pump (only D1703 / V2403-M)	Contact your local Kubota representative
15	Check the condition of the articulation	
6	Replace the V-belt on the engine	

Every 12th month (Annually)

Refer to the contents to find the page number of the sections referred to !

Pos. in fig	Action	Comment
4	Replacing the air filters (main and backup filter)	

Every 24th month (Every other year)

Refer to the contents to find the page number of the sections referred to !

Pos. in fig	Action	Comment
3	Replacing the coolant	
3	Checking cooler hoses and hose clamps	Replace when necessary
	Checking air intake hoses and hose clamps	Replace when necessary

Maintenance, 10h

Every 10 hours of operation (Daily)



***Park the roller on a level surface.
The engine must be switched off and the
parking brake activated when checking or
adjusting the roller, unless otherwise specified.***



***Ensure that there is good ventilation (air
extraction) if the engine is run indoors. Risk of
carbon monoxide poisoning.***



Check - Coolant system

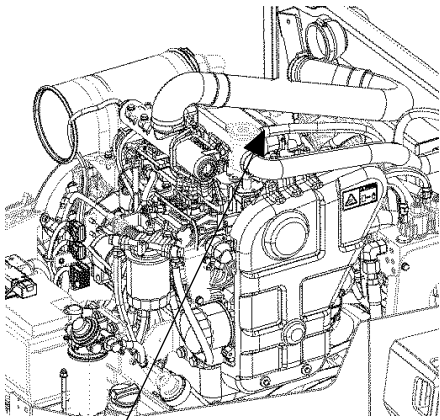

1

**Fig. Cooling water container
(CC1200/C VI)**
1. Filler cap

Check that all hoses/hose connectors are intact and tight. Fill with coolant as specified in the lubricants specification.



Take great care when opening the radiator cap while the engine is hot. Wear protective gloves and goggles.



Also check the freezing point. Change the coolant every other year.

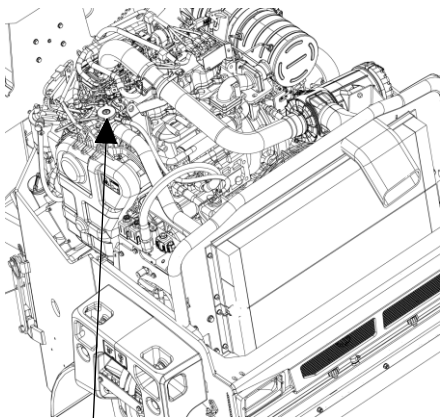

1

**Fig. Cooling water container
(CC1300/C VI - CC1400/C VI)**
1. Filler cap



Diesel engine Check oil level



Ensure that the engine cover is fully open when work is carried out under the cover.

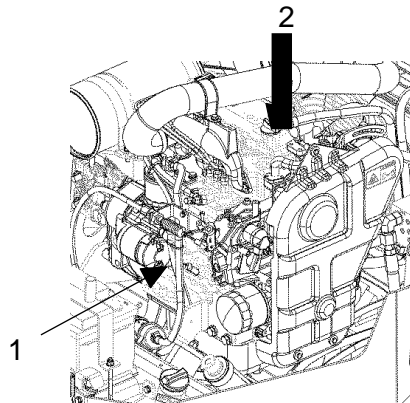

Fig. Engine - D1703 (Stage IIIA)
1. Dipstick
2. Filler cap

Open the engine cover lock and lower the engine cover forwards.

Check the oil level using the dipstick (1). The level should be between the marks. If the level is near the lower mark, top off with fresh engine oil via the filler cap (2). See under the heading lubricants for the correct oil grade.



Never overfill with oil, as this can damage the engine.

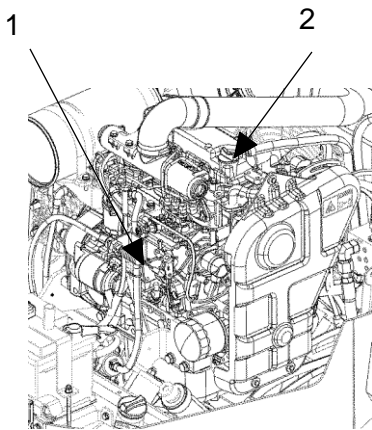

Fig. Diesel engine - D1703 (Tier 4f, CS IV)
1. Dipstick
2. Filler plug

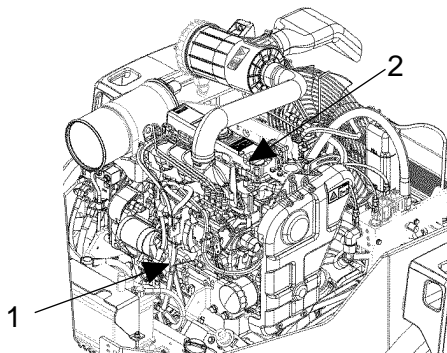

Fig. Diesel engine - V2403-M (R96 & CS IV)
1. Dipstick
2. Filler plug



Hydraulic reservoir, Level check - Filling

Check that the oil level is visible in the sight glass.

Open the engine hood and unscrew the filler cap (2), top up with hydraulic fluid (as per lubricant specification) if the level is too low.

Screw on the cap again after filling.

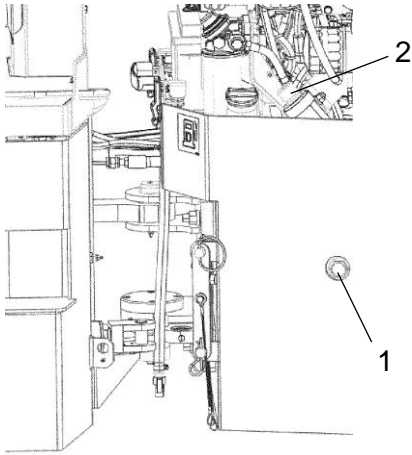

Fig. Hydraulic fluid tank
1. Sight glass
2. Hydraulic fluid refilling

Air circulation - Check

Check that the engine has free circulation of cooling air through the grille (1) in the engine compartment.

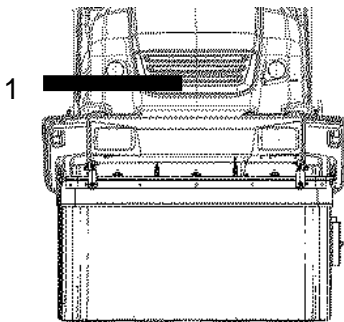

Fig. Front side
1. Cooling air grille



Fuel tank - Filling

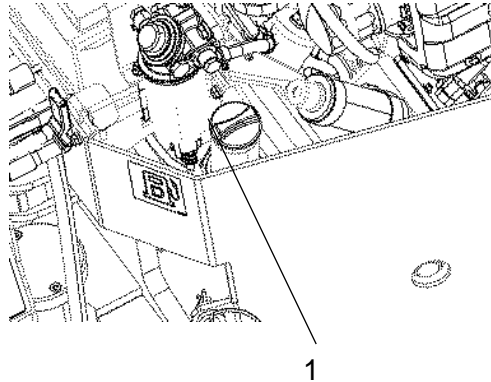

Fig. Fuel tank
1. Filler cap

Refuel the tank every day before starting work.

Open the engine hood, unscrew the tank cap (1) fill with diesel up to the lower edge of the filler pipe.



Tier 4f and CS IV Kubota engines require the use of Ultra Low Sulphur Diesel (ULSD) fuel, which has a sulphur content of 15 ppm (parts per million) or less. Higher sulphur contents cause operating problems and put the useful life of components at risk, which can lead to engine trouble.



Stop the diesel engine. Short-circuit (press) the filler gun against a non-insulated part of the roller before refuelling, and against the filler pipe while refuelling.



Never refuel while the engine is running. Do not smoke and avoid spilling fuel.

The fuel tank holds

CC1200/C VI:	46 liters	(48.6 qts)
CC1300/C VI - CC1400/C VI:	60 liters	(63.4 qts)



Water tank - Filling

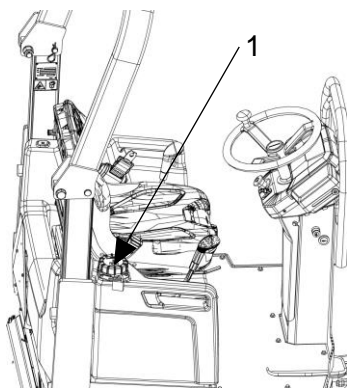

Fig. Water tank
1. Tank cap



Unscrew the tank cap (1) and fill with clean water. Do not remove the strainer. See technical specifications for the tank volume.



Only additive: A small amount of environment-friendly antifreeze.



Sprinkler system/Drum Checking - Cleaning

Start the sprinkler system and make sure that no nozzles (2) are clogged. If necessary, clean clogged nozzles and the coarse filter located by the water pump; see figures below.



Make sure that the watering system is empty/drained of water (sprinkler, hoses, tank/s) or that anti-freeze has been added, to prevent the system freezing. Close the ball valves (1) and draw up the anti-freeze liquid through the filter.

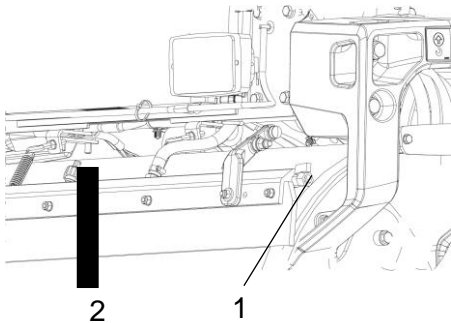

Fig. Drum
1. Ball valve
2. Nozzle

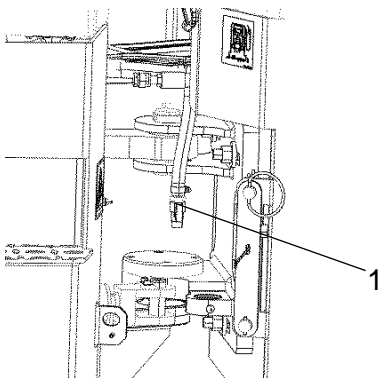

Fig. Articulated joint
1. Ball valve

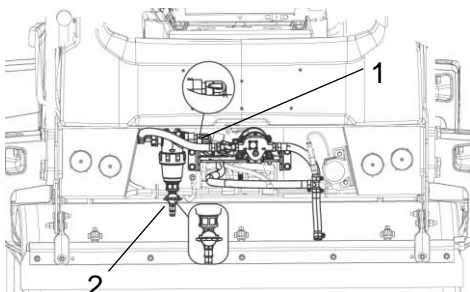

Fig. Sprinkler pump
1. Valve
2. Filter

Sprinkler - Drain / Anti-freeze

Close the valve (1) and open all drains (filter, sprinkler pipes and center drain).

Run the pump for 15 seconds.

Close center and sprinkler drains

Fit a hose and a bottle with antifreeze on the filter (2).

Run the sprinkler pump until the antifreeze has run through all the nozzles.

Stop the sprinkler pump and remove the bottle.

Open all drains and drain the main water tank.

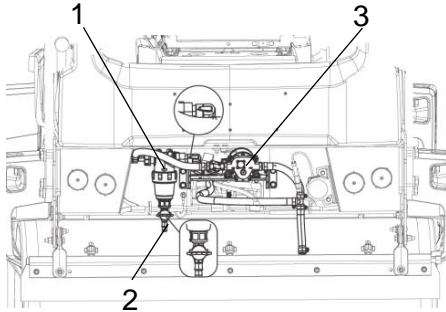

Fig. Pump system
1. Water filter
2. Drain cock
3. Water pump

When cleaning the coarse filter (1), open the cock (2) and loosen the filter housing.

Clean the filter and filter housing. Check that the rubber gasket in the filter housing is intact.

After inspecting and carrying out any necessary cleaning, start the system and check that it works.

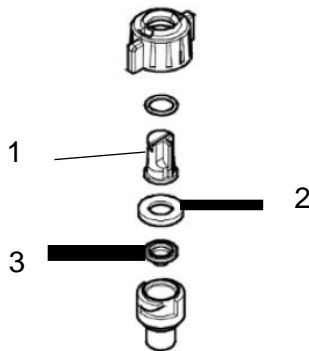

Figure. Nozzle
1. Nozzle
2. Gasket
3. Filter

Sprinkler system/Drum Cleaning of sprinkler nozzle

Dismantle the blocked nozzle by hand.

Blow the nozzle (1) and fine filter (3) clean using compressed air. Alternatively, fit replacement parts and clean the blocked parts later on.

Nozzle	Colour	l/min (at 2.0 bar)	gal/min (at 40 psi)
Standard	yellow	0.63	0.20
Option	blue	0.98	0.30
Option	red	1.31	0.40
Option	brown	1.63	0.50

After inspecting and carrying out any necessary cleaning, start the system and check that it works.



Wear protective goggles when working with compressed air.

Scrapers, fixed Checking - Setting

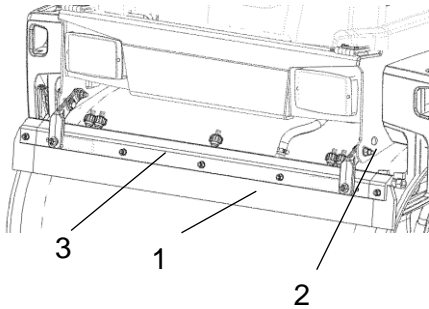

Fig. Drum
1. Scraper blade
2. Adjusting screws
3. Mounting plate

Make sure that the scrapers are undamaged. Adjust the scrapers so that they are 1-2 mm from the drum. For special asphalt compounds, it may be better if the scraper blades (1) lie lightly against the drums.

Asphalt remnants can accumulate on the scraper and affect the contact force. Clean as required.

Loosen the screws (2) to adjust the contact pressure of the scraper blade against the drum.

Lock this setting by tightening the lock nut (2) against the mounting plate (3).

Adjust the contact surface on both scraper attachments.

Remember to tighten all the screws after any adjustment.

Scrapers, spring-action (Optional) Checking - Adjustment

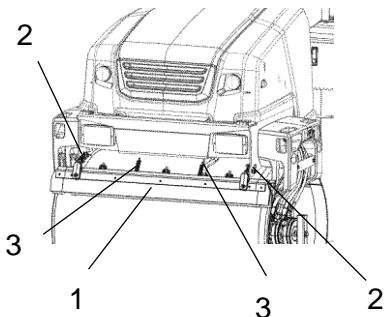

Fig. Spring-action scrapers
1. Scraper blade
2. Adjusting screws
3. Springs



The scrapers must be lifted from the drum during transport.



Brakes - Check

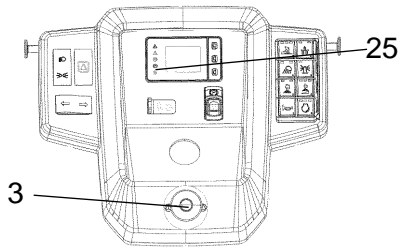

Figure. Instrument panel
3. Emergency stop
25. Parking brake lamp



Check operation of the brakes as follows:

Run the roller very slowly forward. Hold the steering wheel firmly and brace yourself for a sudden stop.

Make sure the parking brake is deactivated and press in the emergency stop (3). The roller will stop abruptly and the engine is switched off.

After testing the brakes, set the forward/reverse lever in neutral.

Pull out the emergency stop (3), activate the parking brake and start the engine.

The roller is now ready for operation.

Refer also to the section in the manual on operation.

Maintenance, first 50h

***Park the roller on a level surface.
The engine must be switched off and the parking brake activated when checking or adjusting the roller, unless otherwise specified.***



Ensure that there is good ventilation (air extraction) if the engine is run indoors. Risk of carbon monoxide poisoning.

**Engine oil and oil filter - Change**

Run the engine until it is warm before draining the oil .

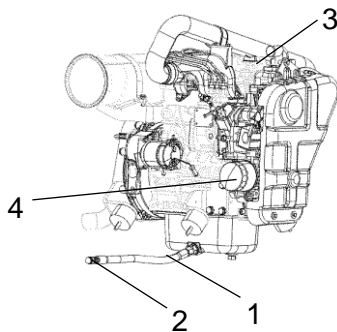

**Fig. Engine compartment right side -
D1703-E3B (Stage IIIA)**

- 1. Drain hose**
- 2. Drain plug**
- 3. Filler cap**
- 4. Oil filter**



Switch off the engine and push in the emergency stop.



***Take great care when draining fluids and oils.
Wear protective gloves and goggles.***

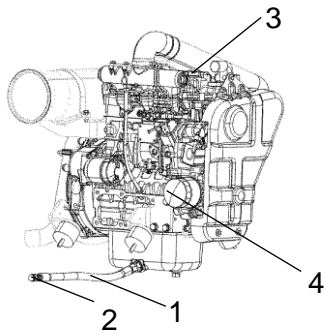

**Fig. Engine compartment, right side -
D1703-E4B (Tier 4f / CS IV)**

- 1. Drainage hose**
- 2. Drain plug**
- 3. Filler cap**
- 4. Oil filter**

Place a receptacle that holds at least 12 liters (8 gal.) under the drain plug (2).

Undo the oil filler cap (3), and undo the drain plug (2) in the end of the drain hose (1). Let all the engine oil flow out.



Deliver the drained oil to special waste handling.



Refer to the engine manual for detailed instructions when changing oil and filters.

Remove the oil filter (4).

Collect any spillage.

Install the new filter.

Fit the drain plug (2) to the end of the hose.

Fill with fresh engine oil. See under the heading lubricants, for the correct oil grade. Fit the filler cap (3) and check that the oil level is correct using the dipstick.

Start the engine and allow it to idle for a few minutes. During this time, check around the oil filter and drain plug for leaks.

Switch off the engine, wait for a minute or so and then check the oil level. Top up with more oil if necessary.

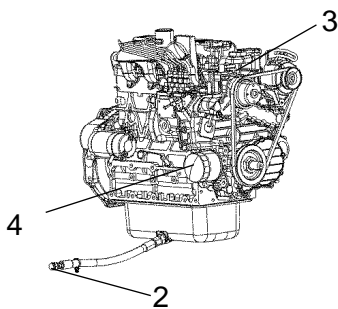

**Fig. Engine compartment right side -
V2403-M-DI-E3B(R96 & CS IV)**

- 2. Drain plug**
- 3. Filler cap**
- 4. Oil filter**



Replacing the hydraulic oil filter

Open the engine hood.

Loosen the red cap (1) and pull up the filter insert (4).

Refit the red cap temporarily to prevent dust and dirt getting into the tank.

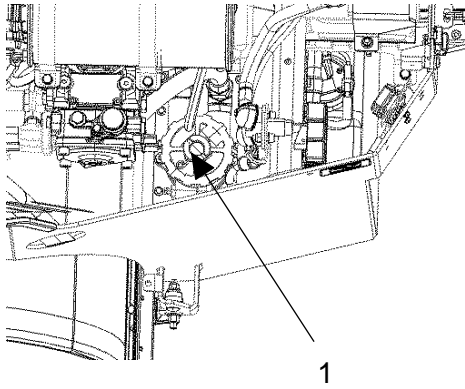

Fig. Engine compartment
1. Filler cap

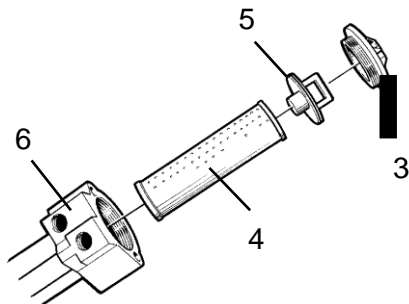

Fig. Hydraulic oil filter
3. Cap
4. Filter insert
5. Handle
6. Filter holder

Release the filter insert (4) from the handle (5).



Remove the filter (4) and hand in to a waste disposal site. This is a disposable filter and cannot be cleaned.

Mount the new insert on the handle, refit the unit into the filter holder (6), and refit the red cover.

Start the engine and allow it to run at full revs for 30 seconds. Check that the filter cap (3) is tight.

Bolted joints
Check

Check that all bolted joints (1) are tightened correctly.

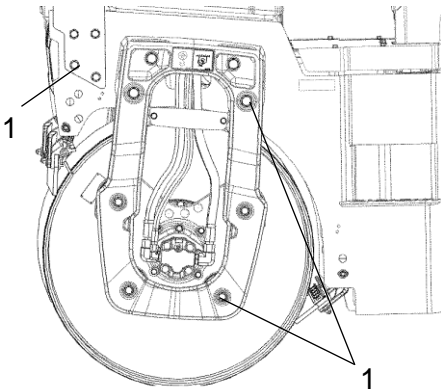

Fig. Drum forks
1. Bolted joints

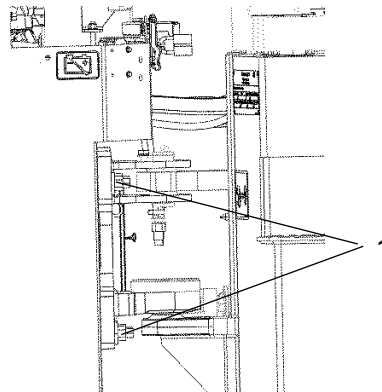

Fig. Articulated joint
1. Bolted joints

Maintenance - 50h

Every 50 hours of operation (Weekly)



***Park the roller on a level surface.
The engine must be switched off and the parking brake activated when checking or adjusting the roller, unless otherwise specified.***



Ensure that there is good ventilation (air extraction) if the engine is run indoors. Risk of carbon monoxide poisoning.

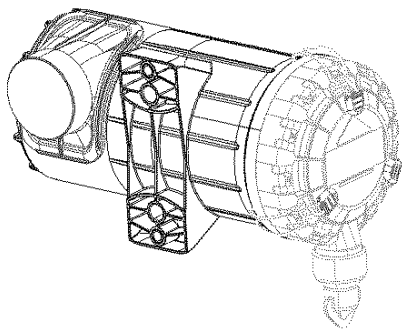

Air cleaner Check main filter



Check the air cleaner's main filter when the indicator shows red. The indicator is mounted on the air cleaner's connecting pipe.

Fig. Air cleaner



Steering cylinder and steering joint - Lubrication

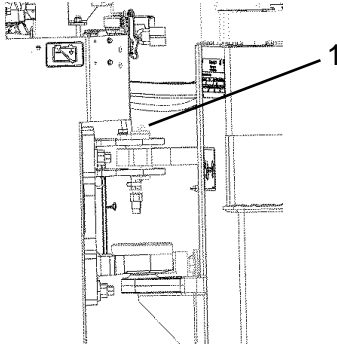

The machine must be in neutral (straight) when lubricated. All five grease nipples (1) can now be accessed.

Wipe the grease nipples (1). Grease each nipple with five strokes of the hand-operated grease gun. Make sure that grease penetrates into the bearing. If grease does not penetrate the bearings, it may be necessary to relieve the articulation joint with a jack while repeating the greasing process.

Fig. Articulation (CC1200/C VI)
1. Lubricant nipples



Do not allow anyone to remain in the vicinity of the steering joint when the engine is running. Danger of crush injury when the steering is operated. Activate the parking brake before lubricating.

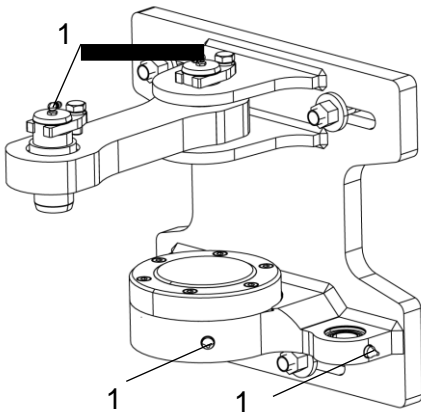

Fig. Articulated joint (CC1300/C VI - CC1400/C VI)
1. Lubricant nipples

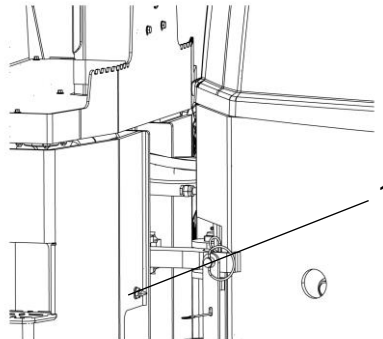

Fig. Rear frame
1. Lubrication nipple

Checking the fuel hoses and hose clamps



Stop the engine before checking or replacing the fuel pipes. Defective fuel pipes can cause a fire.



If the fuel pipes are not connected, plug them at both ends with a clean cloth or paper to prevent dirt from entering. Dirt in the pipes can cause fuel injection pump failure.

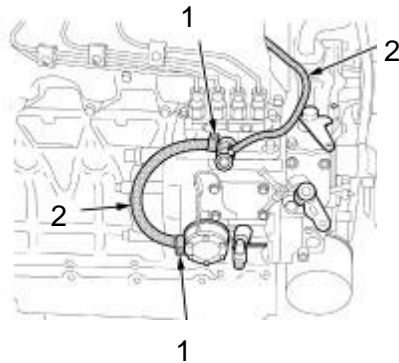

Fig. Engine compartment (D1703 / V2403-M-DI-E3B(R96 & CS IV))

- 1. Hose clamps**
- 2. Fuel pipes**

Check the fuel lines in case:

- Hose clamps are loose. Lubricate the screw in the clamp with oil and tighten the clamp properly.
- Fuel hoses are worn out. Replace them and the hose clamps every other year.

After replacing the pipes and strap, bleed the fuel system.

**Water separator - Draining
(on machines equipped with this)**

If water or contaminants accumulate in the water separator, an indication will be shown on the display.

If this should happen during operation, drain from the draining plug. (1).

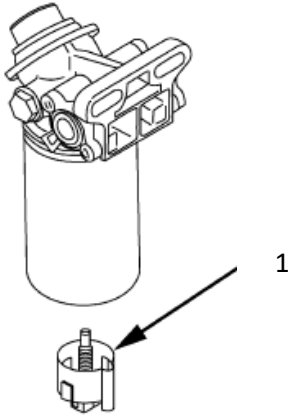

**Fig. Fuel prefilter
1. Drain plug**

Maintenance measures - 250 h

Every 250/750/1250/1750..... hours of operation (every 3 months)



Park the roller on a level surface. The engine must be switched off and the parking brake activated when checking or adjusting the roller, unless otherwise specified.



Ensure that there is good ventilation (air extraction) if the engine is run indoors. Risk of carbon monoxide poisoning.

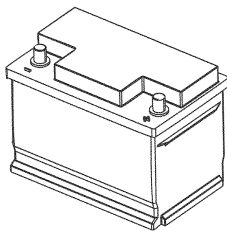

Fig. Battery

Battery - Check condition

The battery is sealed and maintenance-free.



Make sure there is no open flame in the vicinity when checking the electrolyte level. Explosive gas is formed when the alternator charges the battery.



When disconnecting the battery, always disconnect the negative cable first. When connecting the battery, always connect the positive cable first.

The cable shoes should be clean and well-tightened. Corroded cable shoes should be cleaned and greased with acid-free Vaseline.

Wipe the top of the battery.



Engine oil and oil filter - Change

Run the engine until it is warm before draining the oil .

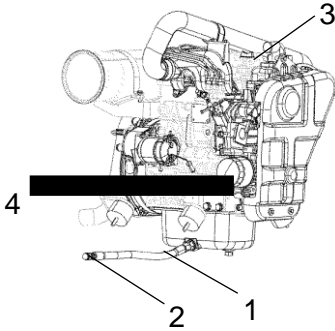

Fig. Engine compartment right side - D1703-E3B (Stage IIIA)

- 1. Drain hose
- 2. Drain plug
- 3. Filler cap
- 4. Oil filter



Switch off the engine and push in the emergency stop.



Take great care when draining fluids and oils. Wear protective gloves and goggles.

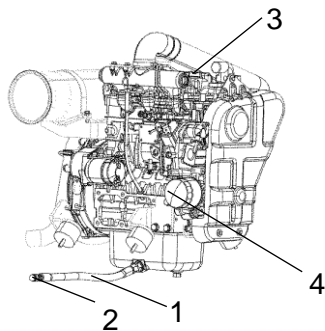

Fig. Engine compartment, right side - D1703-E4B (Tier 4f / CS IV)

- 1. Drainage hose
- 2. Drain plug
- 3. Filler cap
- 4. Oil filter

Place a receptacle that holds at least 12 liters (8 gal.) under the drain plug (2).

Undo the oil filler cap (3), and undo the drain plug (2) in the end of the drain hose (1). Let all the engine oil flow out.



Deliver the drained oil to special waste handling.



Refer to the engine manual for detailed instructions when changing oil and filters.

Remove the oil filter (4).

Collect any spillage.

Install the new filter.

Fit the drain plug (2) to the end of the hose.

Fill with fresh engine oil. See under the heading lubricants, for the correct oil grade. Fit the filler cap (3) and check that the oil level is correct using the dipstick.

Start the engine and allow it to idle for a few minutes. During this time, check around the oil filter and drain plug for leaks.

Switch off the engine, wait for a minute or so and then check the oil level. Top up with more oil if necessary.

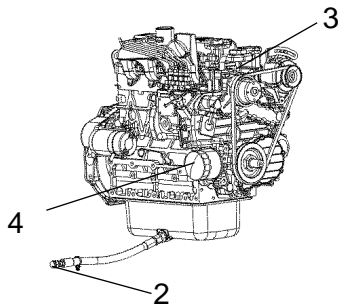
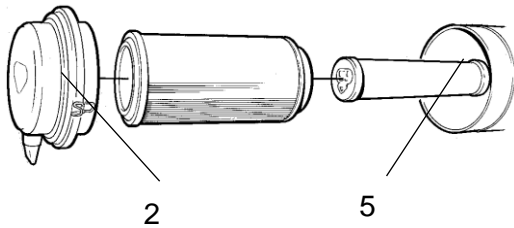

**Fig. Engine compartment right side -
V2403-M-DI-E3B(R96 & CS IV)**

- 2. Drain plug**
- 3. Filler cap**
- 4. Oil filter**



**Air cleaner
- Cleaning**



Wipe the inside of the cover (2) and filter housing (5).

Fig. Air cleaner
2. Cover
5. Filter housing

Wipe clean on both sides of the outlet pipe.

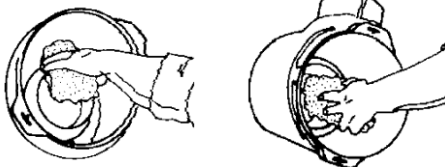

Inner edge of outlet pipe.

Outer edge of outlet pipe.

Wipe also both surfaces for the outlet pipe; see adjacent figure.



Check that the hose clamps between the filter housing and the suction hose are tight and that the hoses are intact. Inspect the entire hose system, all the way to the engine.

Replacing belts/Checking the belt tension

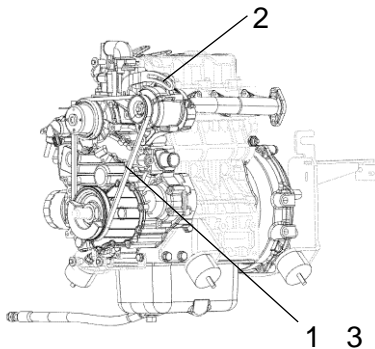

Fig. Diesel engine - D1703 (Tier 4f, CS IV)

- 1. Belt**
- 2. Bolt and nut**
- 3. Deflection between 7 to 9 mm (0.28 to 0.35 in.)**



Exercise care to stop the engine and remove the key before checking the belt tension.



Exercise care to install the standalone safety shield after maintenance or inspection.

Stop the engine and remove the key.

If necessary, remove the belt guard.

Apply a moderate pressure with your thumb on the belt, between the belt pulleys on the alternator and crankshaft, to check the belt tension. The deflection should be between 7 and 9 mm (0.28 to 0.35 in.).

If the belt tension is not sufficient: - Loosen the fastening bolts that hold the alternator in place. - Use a prybar/lever and place it between the alternator and engine block, push the alternator outwards to achieve the required belt tension.

Tighten the bolts holding the alternator with the correct torque.



If the belt is loose or damaged, it may result in insufficient charging. Adjust or replace the belt.

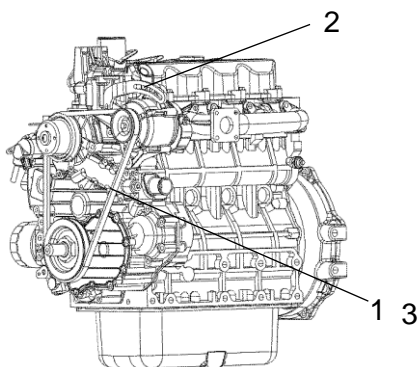
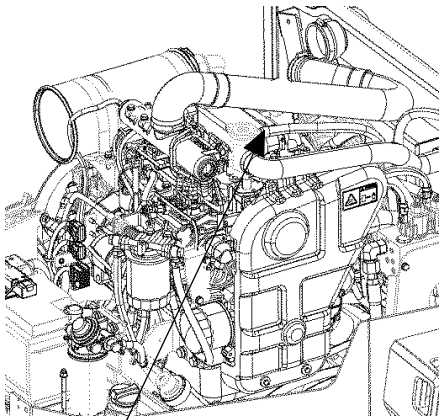

Fig. Diesel engine - V2403-M (R96& CS IV)

- 1. Belt**
- 2. Bolt and nut**
- 3. Deflection between 7 to 9 mm (0.28 to 0.35 in.)**



Check - Coolant system



1

**Fig. Cooling water container
(CC1200/C VI)**
1. Filler cap

Check that all hoses/hose connectors are intact and tight. Fill with coolant as specified in the lubricants specification.



Take great care when opening the radiator cap while the engine is hot. Wear protective gloves and goggles.



Also check the freezing point. Change the coolant every other year.

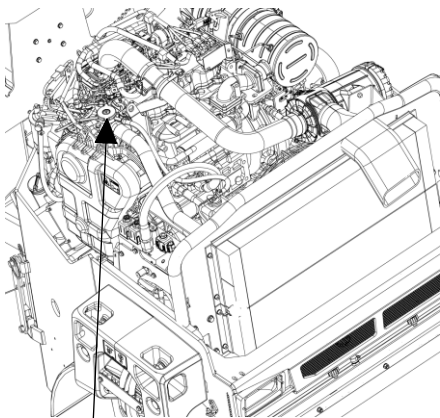

1

**Fig. Cooling water container
(CC1300/C VI - CC1400/C VI)**
1. Filler cap

Check - Air intake hoses

Check that all hoses/hose connections are intact and tight.

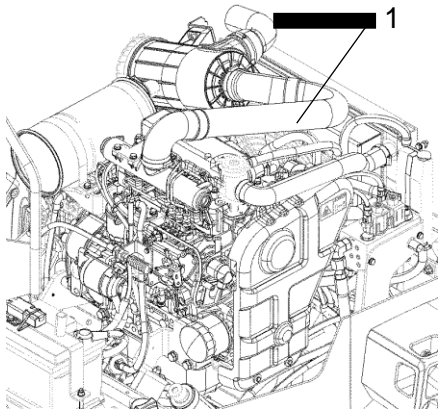

**Fig. Engine compartment -
D1703-M-DI-E4B (Tier 4f, CS IV)**
1. Air intake hoses

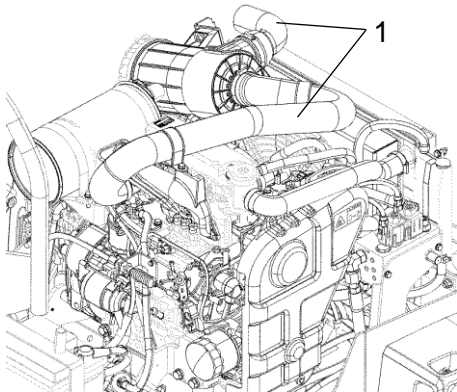

**Fig. Engine compartment -
D1703-M-IDI-E3 (Stage IIIA)**
1. Air intake hoses

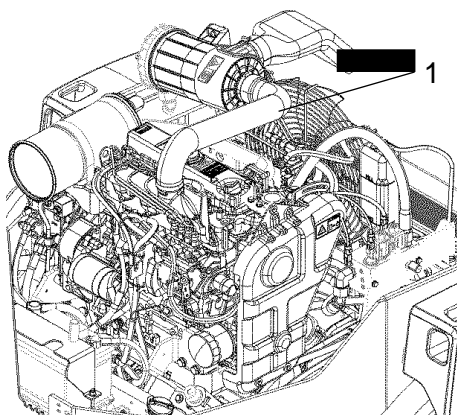

**Fig. Engine compartment - V2403-
M-DI-E3B(R96 & CS IV)**
1. Air intake hoses

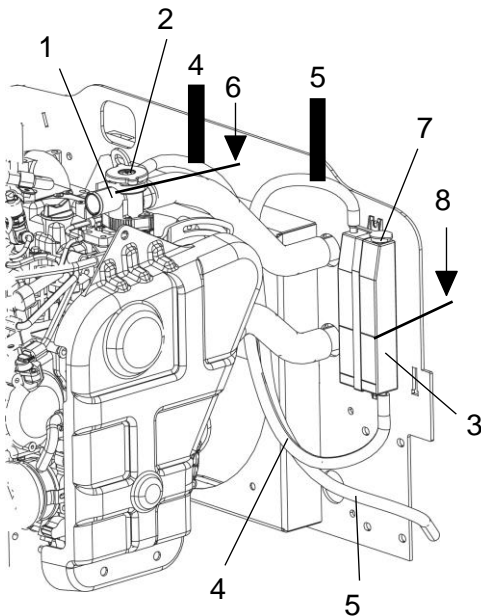

Figure. Cooling water container
1. Filler cap
2. Level marking

Function of the cooling water system (CC1200/C VI)

The thermostat housing (1) cap (2) has two integrated functions:

- To discharge coolant / gas to the return tank (3) via the return hose (4) if the pressure is too high in the system.

The discharged coolant is collected in the return tank (3), while the gas bubbles up through the coolant and is drained out via the hose (5).

- To let in coolant from the return tank (3) and balance the vacuum in the system.

Check - Coolant system

Check that all hoses/hose connectors are intact and tight. Fill with coolant as specified in the lubricants specification.

Filling coolant

Fill the system, via the thermostat housing (1), up to the highest possible level (6).

Remove the filler cap (7) and fill up the return tank (3) to the top marked filling level (8).

When the caps (2, 7) are refitted, start up the engine and allow it to run for about 30 seconds. Then turn it off.

Now repeat the filling procedure.

If the coolant level is at the minimum limit during daily maintenance, fill with coolant up to the top marked filling level (8) in the return tank (3). This should be done when the engine is cold and before it is started.

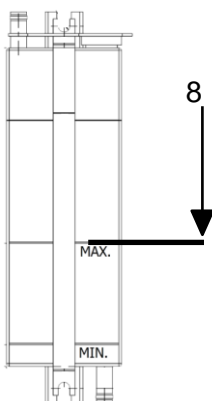

Take great care when opening the radiator cap while the engine is hot. Wear protective gloves and goggles.



Also check the freezing point. Change the coolant every other year.

Fig. Cooling water container
8. Filling level in the return tank



Function of the cooling water system (CC1300/C VI - 1400/C VI)

The thermostat housing (1) cap (2) has two integrated functions:

- To discharge coolant / gas to the return tank (3) via the return hose (4) if the pressure is too high in the system.

The discharged coolant is collected in the return tank (3), while the gas bubbles up through the coolant and is drained out via the hose (5).

- To let in coolant from the return tank (3) and balance the vacuum in the system.

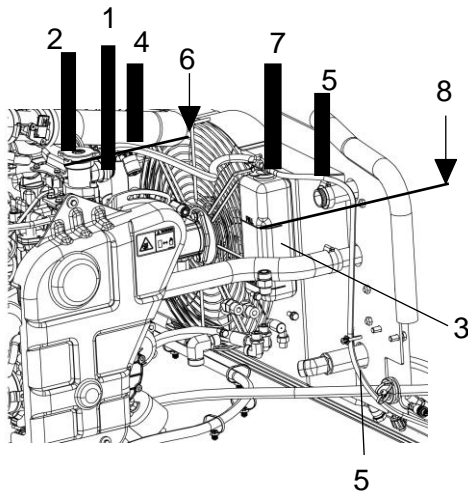

Fig. Cooling water tank
 1. Thermostatic housing
 2. Filler cap
 3. Return tank
 4. Return hose
 5. Drain hose
 6. Fill level in system
 7. Filler cap
 8. Fill level in return tank

Check - Coolant system

Check that all hoses/hose connectors are intact and tight. Fill with coolant as specified in the lubricants specification.

Filling coolant

Fill the system, via the thermostat housing (1), up to the highest possible level (6).

Remove the filler cap (7) and fill up the return tank (3) to the top marked filling level (8).

When the caps (2, 7) are refitted, start up the engine and allow it to run for about 30 seconds. Then turn it off.

Now repeat the filling procedure.

If the coolant level is at the minimum limit during daily maintenance, fill with coolant up to the top marked filling level (8) in the return tank (3). This should be done when the engine is cold and before it is started.

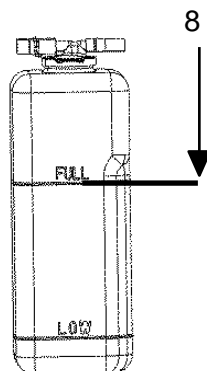

Fig. Cooling water container
 8. Filling level in the return tank



Take great care when opening the radiator cap while the engine is hot. Wear protective gloves and goggles.



Also check the freezing point. Change the coolant every other year.

Maintenance - 500h



Park the roller on a level surface. The engine must be switched off and the parking brake activated when checking or adjusting the roller, unless otherwise specified.



Ensure that there is good ventilation (air extraction) if the engine is run indoors. Risk of carbon monoxide poisoning.

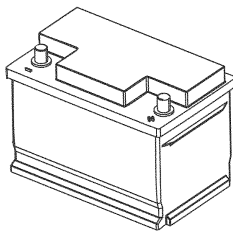

Fig. Battery

Battery - Check condition

The battery is sealed and maintenance-free.



Make sure there is no open flame in the vicinity when checking the electrolyte level. Explosive gas is formed when the alternator charges the battery.



When disconnecting the battery, always disconnect the negative cable first. When connecting the battery, always connect the positive cable first.

The cable shoes should be clean and well-tightened. Corroded cable shoes should be cleaned and greased with acid-free Vaseline.

Wipe the top of the battery.



Engine oil and oil filter - Change

Run the engine until it is warm before draining the oil .

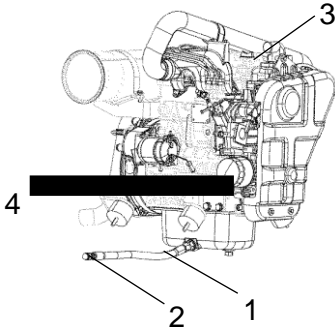

Fig. Engine compartment right side - D1703-E3B (Stage IIIA)

- 1. Drain hose
- 2. Drain plug
- 3. Filler cap
- 4. Oil filter



Switch off the engine and push in the emergency stop.



Take great care when draining fluids and oils. Wear protective gloves and goggles.

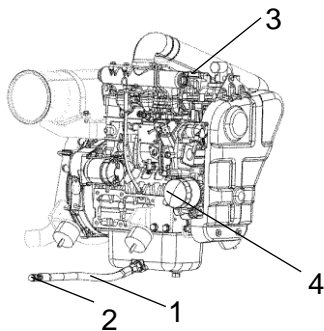

Fig. Engine compartment, right side - D1703-E4B (Tier 4f / CS IV)

- 1. Drainage hose
- 2. Drain plug
- 3. Filler cap
- 4. Oil filter

Place a receptacle that holds at least 12 liters (8 gal.) under the drain plug (2).

Undo the oil filler cap (3), and undo the drain plug (2) in the end of the drain hose (1). Let all the engine oil flow out.



Deliver the drained oil to special waste handling.



Refer to the engine manual for detailed instructions when changing oil and filters.

Remove the oil filter (4).

Collect any spillage.

Install the new filter.

Fit the drain plug (2) to the end of the hose.

Fill with fresh engine oil. See under the heading lubricants, for the correct oil grade. Fit the filler cap (3) and check that the oil level is correct using the dipstick.

Start the engine and allow it to idle for a few minutes. During this time, check around the oil filter and drain plug for leaks.

Switch off the engine, wait for a minute or so and then check the oil level. Top up with more oil if necessary.

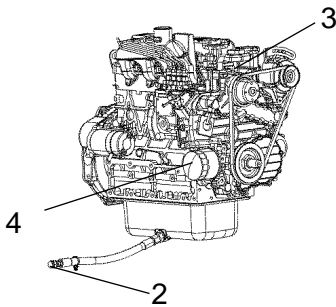

**Fig. Engine compartment right side -
V2403-M-DI-E3B(R96 & CS IV)**

- 2. Drain plug**
- 3. Filler cap**
- 4. Oil filter**



Drum - oil level Inspection - filling

Run the roller slowly until the oil plug (1) is positioned as illustrated.

Make sure that the marking (2) on the drum end faces downward before starting work.

Unscrew the plug and check that the oil level reaches up to the bottom of the hole. Top up with new oil if necessary. Use oil as per the lubricant specification.

Clean the magnetic oil plug (1) from any metallic residue, and refit the plug.

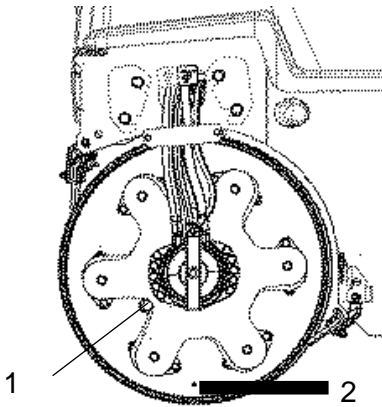

Fig. Drum, vibration side (CC1200/C VI)
1. Oil drain plug
2. Marking on the drum end

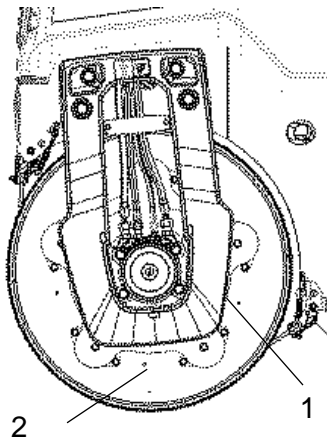

Fig. Drum vibration side (CC1300/C VI - CC1400/C VI)
1. Oil drain plug
2. Marking on the drum end

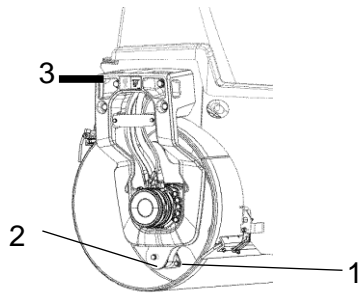

Fig. Drum end
1. Rubber element
2. Fastening screws
3. Bolted joints

Rubber elements and bolted joints Check

Check all rubber elements (1). Replace all elements where more than 25% of the elements on one side of the drum have cracks deeper than 10-15 mm (0.4-0.6 in).

Check using a knife blade or pointed object.

Check also that the attachment screws (2) are tightened.

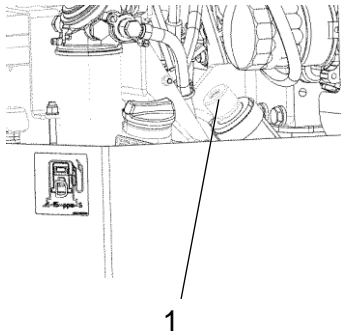

Fig. Engine compartment
1. Tank cap, hydraulic fluid

Hydraulic reservoir cap - Check

Screw off the tank cap (1) and check that it is not clogged. Air must have unobstructed passage through the cap in both directions.

If clogged in either direction, clean with a little diesel oil and blow with compressed air until free passage is assured or replace the cap with a new one.



Wear protective goggles when working with compressed air.



Steering cylinder and steering joint - Lubrication

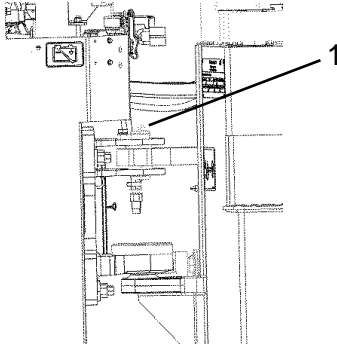

The machine must be in neutral (straight) when lubricated. All five grease nipples (1) can now be accessed.

Wipe the grease nipples (1). Grease each nipple with five strokes of the hand-operated grease gun. Make sure that grease penetrates into the bearing. If grease does not penetrate the bearings, it may be necessary to relieve the articulation joint with a jack while repeating the greasing process.

Fig. Articulation (CC1200/C VI)
1. Lubricant nipples



Do not allow anyone to remain in the vicinity of the steering joint when the engine is running. Danger of crush injury when the steering is operated. Activate the parking brake before lubricating.

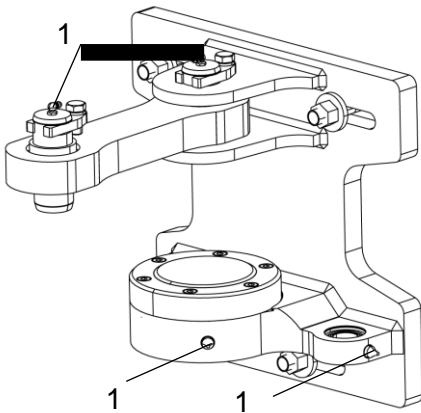

Fig. Articulated joint (CC1300/C VI - CC1400/C VI)
1. Lubricant nipples

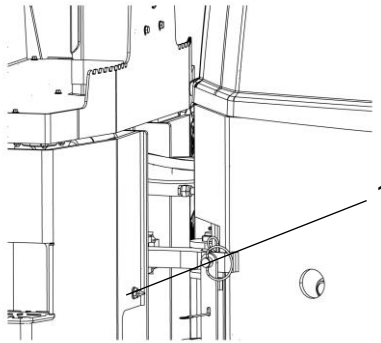
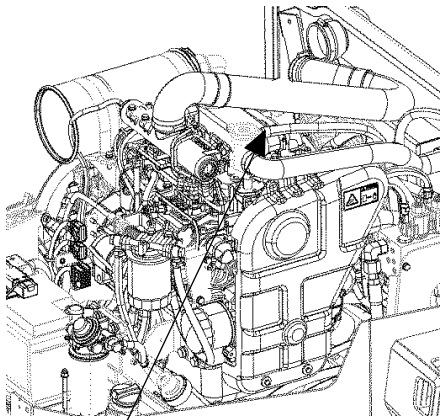

Fig. Rear frame
1. Lubrication nipple



Check - Coolant system



1

**Fig. Cooling water container
(CC1200/C VI)**
1. Filler cap

Check that all hoses/hose connectors are intact and tight. Fill with coolant as specified in the lubricants specification.



Take great care when opening the radiator cap while the engine is hot. Wear protective gloves and goggles.



Also check the freezing point. Change the coolant every other year.

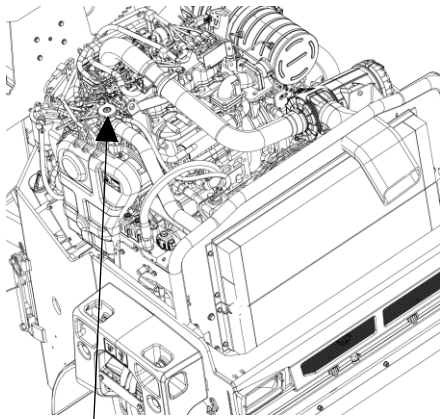

1

**Fig. Cooling water container
(CC1300/C VI - CC1400/C VI)**
1. Filler cap



Air cleaner Check - Replacement of main filter



Replace the air cleaner's main filter when the indicator shows red. The indicator is located on the filter, or in its immediate vicinity.

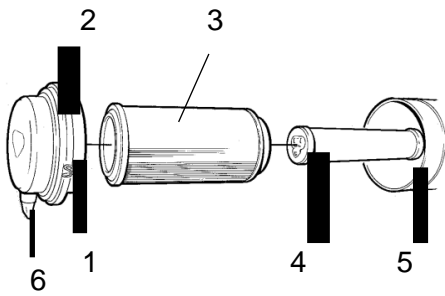

Fig. Air cleaner
1. Clips
2. Cover
3. Main filter
4. Backup filter
5. Filter housing
6. Dust valve

Release the clips (1), pull off the cover (2), and pull out the main filter (3).

Do not remove the backup filter (4).

Clean the air cleaner if necessary, see section Air cleaner - Cleaning.

When replacing the main filter (3), insert a new filter and refit the air cleaner in the reverse order.

Check the condition of the dust valve (6); replace if necessary.

When refitting the cover, make sure that the dust valve is positioned downwards.

Air filter indicator - Resetting

The air filter indicator is located on the filter, or in its immediate vicinity.

The air filter indicator must be reset after replacing the air filter.

Press the "button" (1) on the top of the indicator to reset.

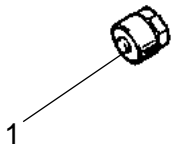

Fig. Indicator
1. Button



Replacing the fuel filter

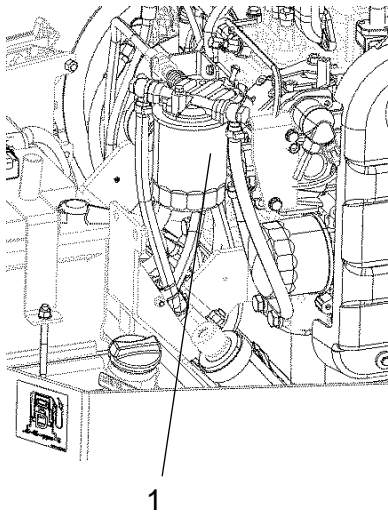

Fig. Engine compartment, right side
1. Fuel filter



Place a container underneath to collect fuel that runs out when the filter is released.

Screw off the fuel filter (1). The filter is of the disposable type and cannot be cleaned. Hand in to a waste disposal site.

Install the new filter.

Start the engine and check that the fuel filter is tight.



Refer to the engine manual for detailed instructions when replacing the fuel filter.



Ensure good ventilation (air extraction) if the diesel engine is run indoors. Risk of carbon monoxide poisoning.



Replacing the pre-filter

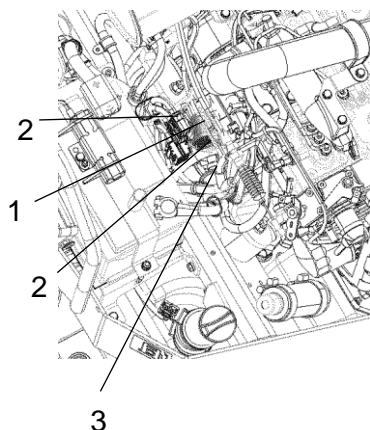

Fig. Engine compartment -
D1703-M-IDI-E3 (Stage IIIA) /
V2403-M-DI-E3B(R96 & CS
IV)

1. Pre-filter
2. Hose clamps
3. Fuel pump

Activate the parking brake.
Switch off the engine and open the engine hood.



Place a container underneath to collect fuel that runs out when the filter is released.

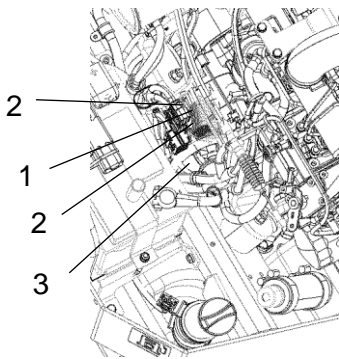

Fig. Engine compartment - D1703-M-DI-E4B (Tier 4f / CS IV)
 1. Pre-filter
 2. Hose clamps
 3. Fuel pump

D1703 / V2403-M-DI-E3B(R96 & CS IV)

The prefilter is located to the left of the fuel pump in the engine compartment.

Loosen the hose clamps (2) using a screwdriver.

Remove the pre-filter (1) and hand in to a waste disposal site. This is a disposable filter and cannot be cleaned.

Fit a new pre-filter and tighten the hose clamps.

Start the engine and check that the pre-filter is tight.



Ensure good ventilation (air extraction) if the diesel engine is run indoors. Risk of carbon monoxide poisoning.



Fuel tank - Cleaning

It is easiest to clean the tank when it is almost empty.



Pump out any bottom sediment using a suitable pump, such as an oil drain pump. Save the oil in a container and dispose of it in an approved manner.

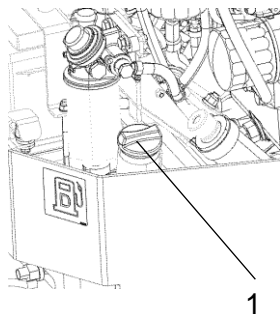

Fig. Fuel tank
 1. Fuel tank



Keep in mind fire risk when handling fuel.



The fuel tank is made of plastic (polyethylene) and is recyclable.

Check - Air intake hoses

Check that all hoses/hose connections are intact and tight.

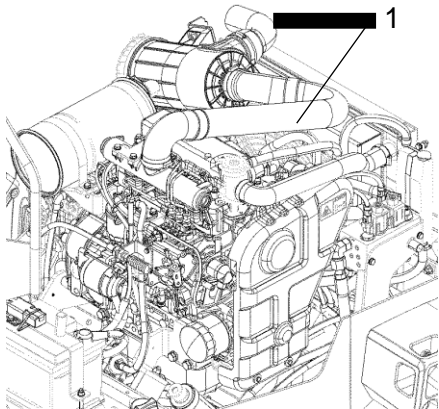

**Fig. Engine compartment -
D1703-M-DI-E4B (Tier 4f, CS IV)**
1. Air intake hoses

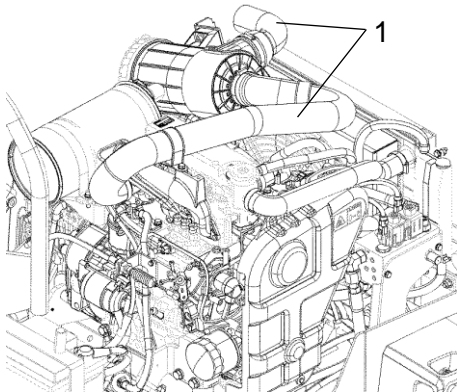

**Fig. Engine compartment -
D1703-M-IDI-E3 (Stage IIIA)**
1. Air intake hoses

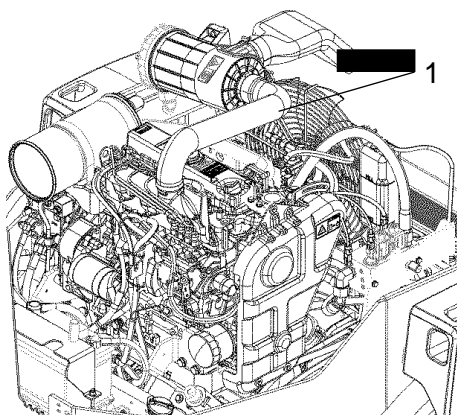
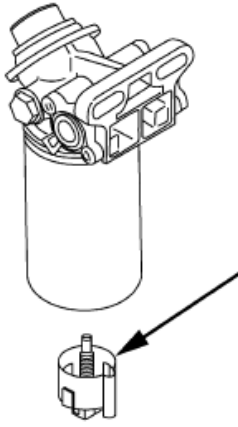

**Fig. Engine compartment - V2403-
M-DI-E3B(R96 & CS IV)**
1. Air intake hoses

**Fuel filter's water separator - Draining
(on machines equipped with this)**

If water or contaminants accumulate in the fuel filter's water separator, an indication will be shown on the display.

If this should happen during operation, drain from the draining plug. (1).



*Fig. Fuel prefilter
1. Drain plug*

Replacing belts/Checking the belt tension



Exercise care to stop the engine and remove the key before checking the belt tension.



Exercise care to install the standalone safety shield after maintenance or inspection.

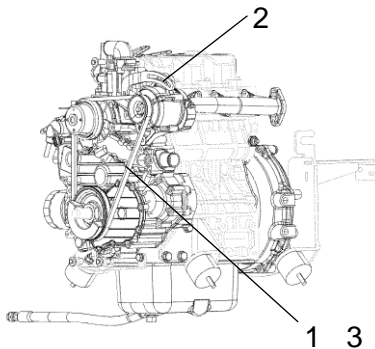

Fig. Diesel engine - D1703 (Tier 4f, CS IV)

- 1. Belt**
- 2. Bolt and nut**
- 3. Deflection between 7 to 9 mm (0.28 to 0.35 in.)**

Stop the engine and remove the key.

If necessary, remove the belt guard.

Apply a moderate pressure with your thumb on the belt, between the belt pulleys on the alternator and crankshaft, to check the belt tension. The deflection should be between 7 and 9 mm (0.28 to 0.35 in.).

If the belt tension is not sufficient: - Loosen the fastening bolts that hold the alternator in place. - Use a prybar/lever and place it between the alternator and engine block, push the alternator outwards to achieve the required belt tension.

Tighten the bolts holding the alternator with the correct torque.



If the belt is loose or damaged, it may result in insufficient charging. Adjust or replace the belt.

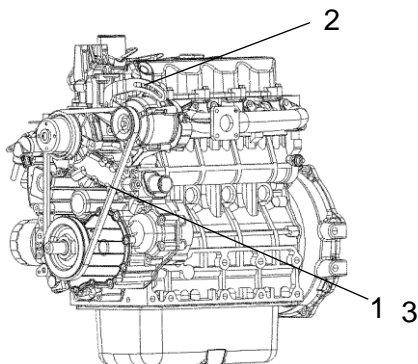

Fig. Diesel engine - V2403-M (R96 & CS IV)

- 1. Belt**
- 2. Bolt and nut**
- 3. Deflection between 7 to 9 mm (0.28 to 0.35 in.)**



Coolers Checking - Cleaning

Make sure that the air flow through the coolers (1) and (2) is unobstructed. Dirty coolers are blown clean with compressed air or washed clean using a high-pressure water cleaner.

Blow air or direct water through the cooler in the opposite direction to that of the cooling air.

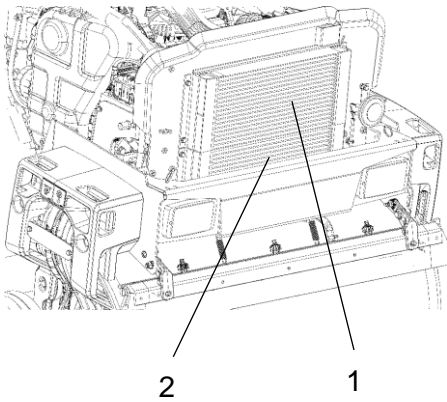

Fig. Engine compartment (CC1200/C VI)

- 1. Water cooler
- 2. Hydraulic fluid cooler



Take care when using a high-pressure water jet. Do not hold the nozzle too near the cooler.



Wear protective goggles when working with compressed air or high-pressure water jets.

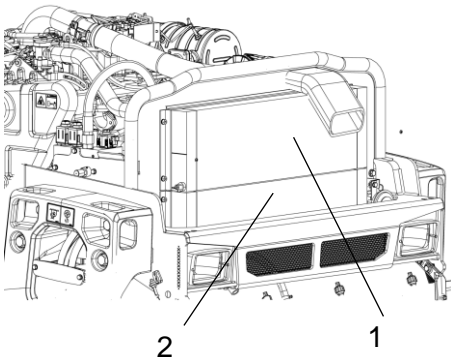

Fig. Engine compartment (CC1300/C VI - CC1400/C VI)

- 1. Radiator
- 2. Hydraulic fluid cooler

Maintenance - 1000h

Performed after 1000 operating hours (each year)



***Park the roller on a level surface.
The engine must be switched off and the parking brake activated when checking or adjusting the roller, unless otherwise specified.***



Ensure that there is good ventilation (air extraction) if the engine is run indoors. Risk of carbon monoxide poisoning.

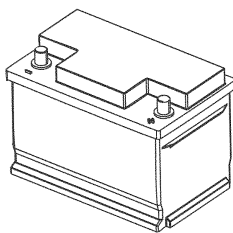

Fig. Battery

**Battery
- Check condition**

The battery is sealed and maintenance-free.



Make sure there is no open flame in the vicinity when checking the electrolyte level. Explosive gas is formed when the alternator charges the battery.



When disconnecting the battery, always disconnect the negative cable first. When connecting the battery, always connect the positive cable first.

The cable shoes should be clean and well-tightened. Corroded cable shoes should be cleaned and greased with acid-free Vaseline.

Wipe the top of the battery.



Engine oil and oil filter - Change

Run the engine until it is warm before draining the oil .

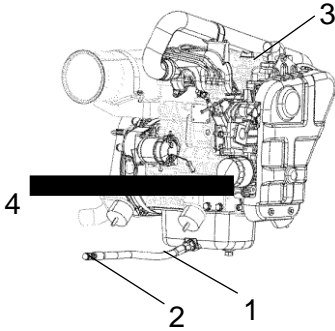

Fig. Engine compartment right side - D1703-E3B (Stage IIIA)

- 1. Drain hose
- 2. Drain plug
- 3. Filler cap
- 4. Oil filter



Switch off the engine and push in the emergency stop.



Take great care when draining fluids and oils. Wear protective gloves and goggles.

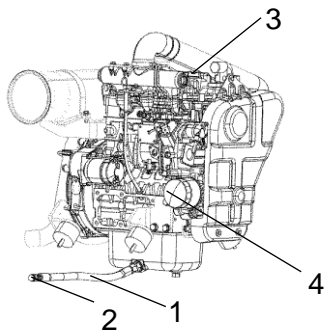

Fig. Engine compartment, right side - D1703-E4B (Tier 4f / CS IV)

- 1. Drainage hose
- 2. Drain plug
- 3. Filler cap
- 4. Oil filter

Place a receptacle that holds at least 12 liters (8 gal.) under the drain plug (2).

Undo the oil filler cap (3), and undo the drain plug (2) in the end of the drain hose (1). Let all the engine oil flow out.



Deliver the drained oil to special waste handling.



Refer to the engine manual for detailed instructions when changing oil and filters.

Remove the oil filter (4).

Collect any spillage.

Install the new filter.

Fit the drain plug (2) to the end of the hose.

Fill with fresh engine oil. See under the heading lubricants, for the correct oil grade. Fit the filler cap (3) and check that the oil level is correct using the dipstick.

Start the engine and allow it to idle for a few minutes. During this time, check around the oil filter and drain plug for leaks.

Switch off the engine, wait for a minute or so and then check the oil level. Top up with more oil if necessary.

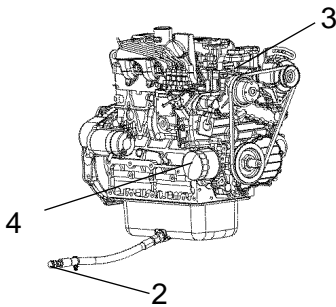

**Fig. Engine compartment right side -
V2403-M-DI-E3B(R96 & CS IV)**

- 2. Drain plug**
- 3. Filler cap**
- 4. Oil filter**



Drum - oil level Inspection - filling

Run the roller slowly until the oil plug (1) is positioned as illustrated.

Make sure that the marking (2) on the drum end faces downward before starting work.

Unscrew the plug and check that the oil level reaches up to the bottom of the hole. Top up with new oil if necessary. Use oil as per the lubricant specification.

Clean the magnetic oil plug (1) from any metallic residue, and refit the plug.

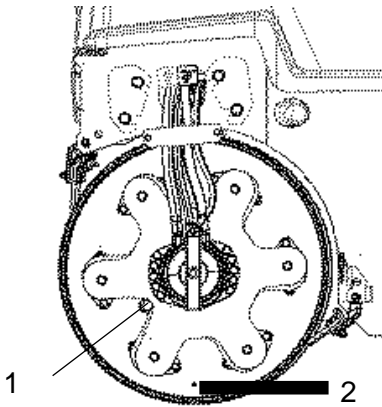

Fig. Drum, vibration side (CC1200/C VI)

- 1. Oil drain plug
- 2. Marking on the drum end

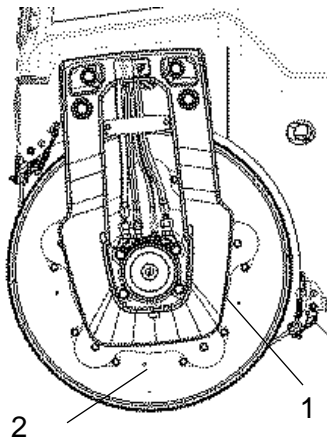

Fig. Drum vibration side (CC1300/C VI - CC1400/C VI)

- 1. Oil drain plug
- 2. Marking on the drum end

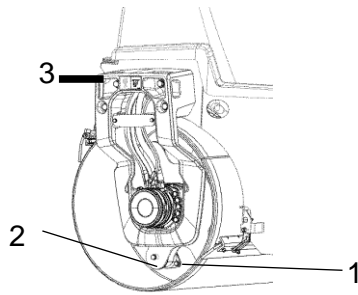

Fig. Drum end
1. Rubber element
2. Fastening screws
3. Bolted joints

Rubber elements and bolted joints Check

Check all rubber elements (1). Replace all elements where more than 25% of the elements on one side of the drum have cracks deeper than 10-15 mm (0.4-0.6 in).

Check using a knife blade or pointed object.

Check also that the attachment screws (2) are tightened.

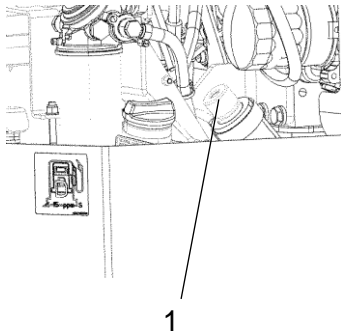

Fig. Engine compartment
1. Tank cap, hydraulic fluid

Hydraulic reservoir cap - Check

Screw off the tank cap (1) and check that it is not clogged. Air must have unobstructed passage through the cap in both directions.

If clogged in either direction, clean with a little diesel oil and blow with compressed air until free passage is assured or replace the cap with a new one.



Wear protective goggles when working with compressed air.



Steering cylinder and steering joint - Lubrication

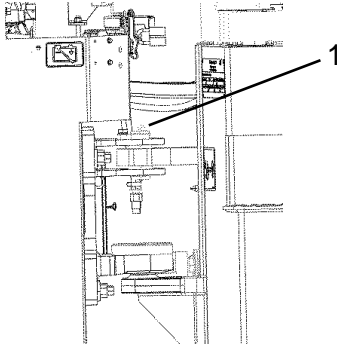

The machine must be in neutral (straight) when lubricated. All five grease nipples (1) can now be accessed.

Wipe the grease nipples (1). Grease each nipple with five strokes of the hand-operated grease gun. Make sure that grease penetrates into the bearing. If grease does not penetrate the bearings, it may be necessary to relieve the articulation joint with a jack while repeating the greasing process.

Fig. Articulation (CC1200/C VI)
1. Lubricant nipples



Do not allow anyone to remain in the vicinity of the steering joint when the engine is running. Danger of crush injury when the steering is operated. Activate the parking brake before lubricating.

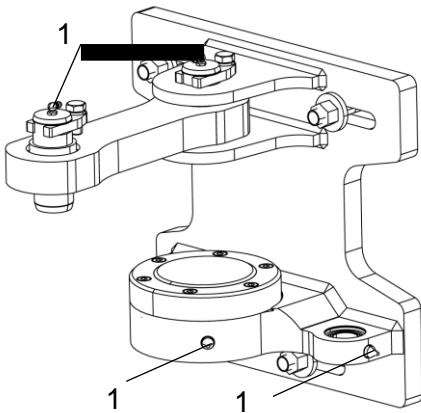

Fig. Articulated joint (CC1300/C VI - CC1400/C VI)
1. Lubricant nipples

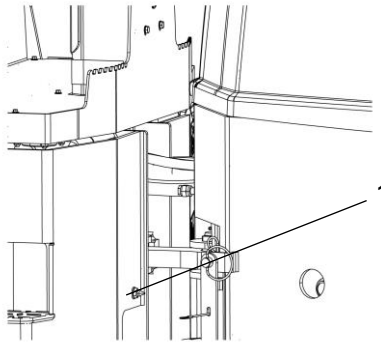
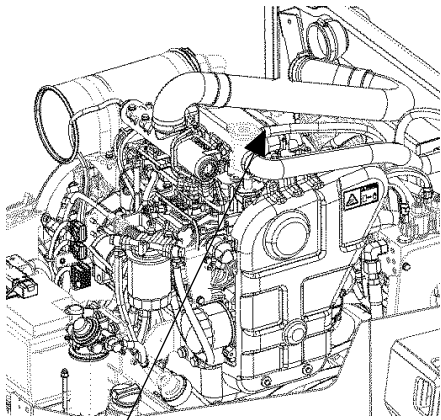

Fig. Rear frame
1. Lubrication nipple



Check - Coolant system



1

**Fig. Cooling water container
(CC1200/C VI)**
1. Filler cap

Check that all hoses/hose connectors are intact and tight. Fill with coolant as specified in the lubricants specification.



Take great care when opening the radiator cap while the engine is hot. Wear protective gloves and goggles.



Also check the freezing point. Change the coolant every other year.

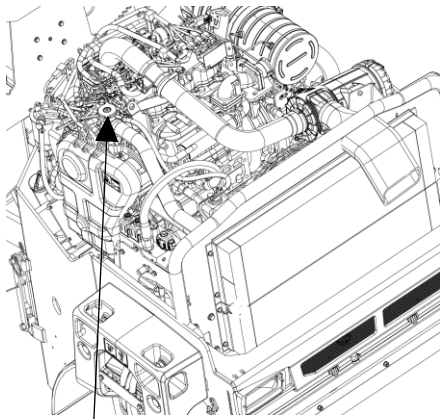

1

**Fig. Cooling water container
(CC1300/C VI - CC1400/C VI)**
1. Filler cap



Air cleaner Check - Replacement of main filter



Replace the air cleaner's main filter when the indicator shows red. The indicator is located on the filter, or in its immediate vicinity.

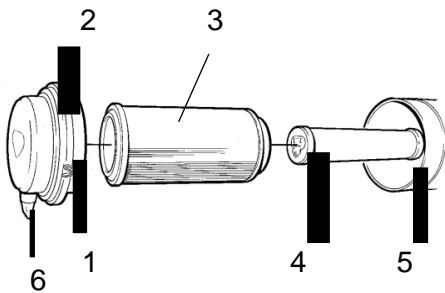

Fig. Air cleaner
 1. Clips
 2. Cover
 3. Main filter
 4. Backup filter
 5. Filter housing
 6. Dust valve

Release the clips (1), pull off the cover (2), and pull out the main filter (3).

Do not remove the backup filter (4).

Clean the air cleaner if necessary, see section Air cleaner - Cleaning.

When replacing the main filter (3), insert a new filter and refit the air cleaner in the reverse order.

Check the condition of the dust valve (6); replace if necessary.

When refitting the cover, make sure that the dust valve is positioned downwards.

Air filter indicator - Resetting

The air filter indicator is located on the filter, or in its immediate vicinity.

The air filter indicator must be reset after replacing the air filter.

Press the "button" (1) on the top of the indicator to reset.

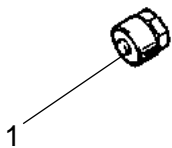

Fig. Indicator
 1. Button



Backup filter - Change

Change the backup filter with a new filter after every third replacement of the main filter.

To change the backup filter (1), pull the old filter out of its holder, insert a new filter and reassemble the air cleaner in the reverse order.

Clean the air cleaner if necessary, see section Air cleaner - Cleaning.

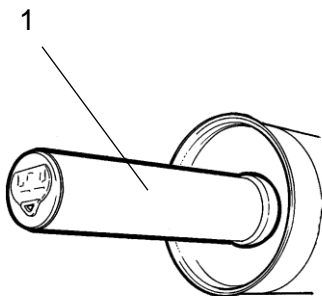

Fig. Air filter
 1. Backup filter



Replacing the hydraulic oil filter

Open the engine hood.

Loosen the red cap (1) and pull up the filter insert (4).

Refit the red cap temporarily to prevent dust and dirt getting into the tank.

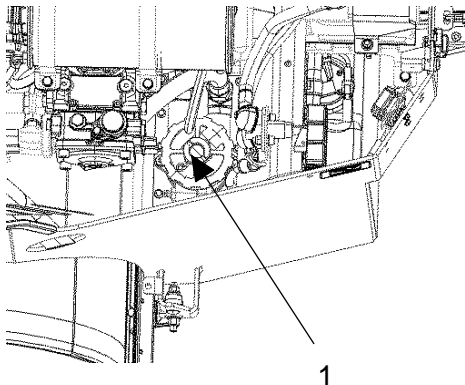

Fig. Engine compartment
1. Filler cap

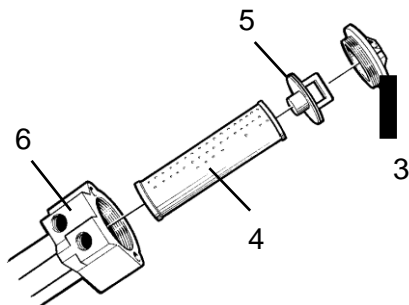

Fig. Hydraulic oil filter
3. Cap
4. Filter insert
5. Handle
6. Filter holder

Release the filter insert (4) from the handle (5).



Remove the filter (4) and hand in to a waste disposal site. This is a disposable filter and cannot be cleaned.

Mount the new insert on the handle, refit the unit into the filter holder (6), and refit the red cover.

Start the engine and allow it to run at full revs for 30 seconds. Check that the filter cap (3) is tight.



Replacing the fuel filter



Place a container underneath to collect fuel that runs out when the filter is released.

Screw off the fuel filter (1). The filter is of the disposable type and cannot be cleaned. Hand in to a waste disposal site.

Install the new filter.

Start the engine and check that the fuel filter is tight.



Refer to the engine manual for detailed instructions when replacing the fuel filter.



Ensure good ventilation (air extraction) if the diesel engine is run indoors. Risk of carbon monoxide poisoning.

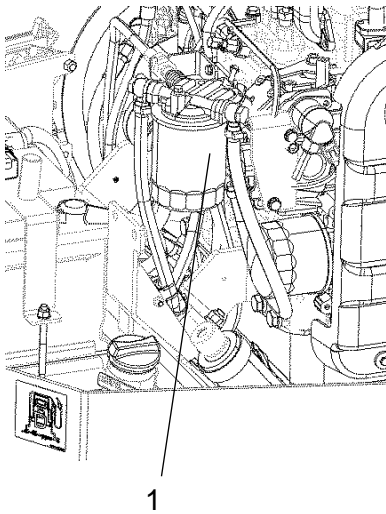

Fig. Engine compartment, right side
1. Fuel filter



Replacing the pre-filter

Activate the parking brake.

Switch off the engine and open the engine hood.



Place a container underneath to collect fuel that runs out when the filter is released.

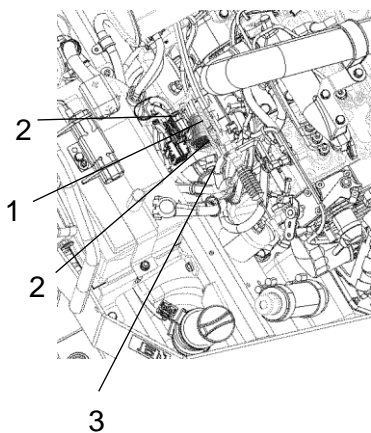
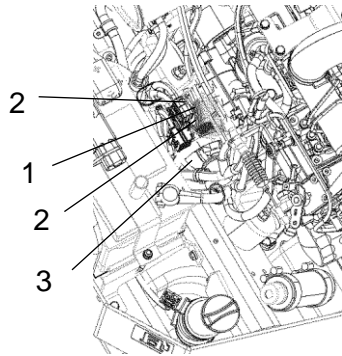

Fig. Engine compartment -
D1703-M-DI-E3 (Stage IIIA) /
V2403-M-DI-E3B(R96 & CS
IV)

1. Pre-filter
2. Hose clamps
3. Fuel pump



**Fig. Engine compartment -
D1703-M-DI-E4B (Tier 4f / CS IV)**
1. Pre-filter
2. Hose clamps
3. Fuel pump

D1703 / V2403-M-DI-E3B(R96 & CS IV)

The prefilter is located to the left of the fuel pump in the engine compartment.

Loosen the hose clamps (2) using a screwdriver.

Remove the pre-filter (1) and hand in to a waste disposal site. This is a disposable filter and cannot be cleaned.

Fit a new pre-filter and tighten the hose clamps.

Start the engine and check that the pre-filter is tight.



Ensure good ventilation (air extraction) if the diesel engine is run indoors. Risk of carbon monoxide poisoning.



Fuel tank - Cleaning

It is easiest to clean the tank when it is almost empty.



Pump out any bottom sediment using a suitable pump, such as an oil drain pump. Save the oil in a container and dispose of it in an approved manner.



Keep in mind fire risk when handling fuel.



The fuel tank is made of plastic (polyethylene) and is recyclable.

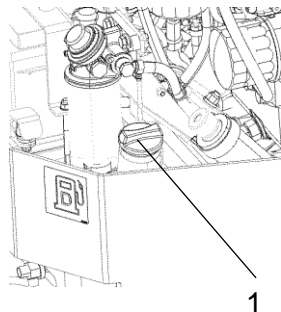

Fig. Fuel tank
1. Fuel tank

Replacing belts/Checking the belt tension

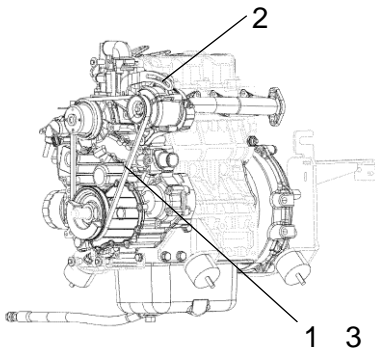

Fig. Diesel engine - D1703 (Tier 4f, CS IV)

- 1. Belt
- 2. Bolt and nut
- 3. Deflection between 7 to 9 mm (0.28 to 0.35 in.)



Exercise care to stop the engine and remove the key before checking the belt tension.



Exercise care to install the standalone safety shield after maintenance or inspection.

Stop the engine and remove the key.

If necessary, remove the belt guard.

Apply a moderate pressure with your thumb on the belt, between the belt pulleys on the alternator and crankshaft, to check the belt tension. The deflection should be between 7 and 9 mm (0.28 to 0.35 in.).

If the belt tension is not sufficient: - Loosen the fastening bolts that hold the alternator in place. - Use a prybar/lever and place it between the alternator and engine block, push the alternator outwards to achieve the required belt tension.

Tighten the bolts holding the alternator with the correct torque.



If the belt is loose or damaged, it may result in insufficient charging. Adjust or replace the belt.

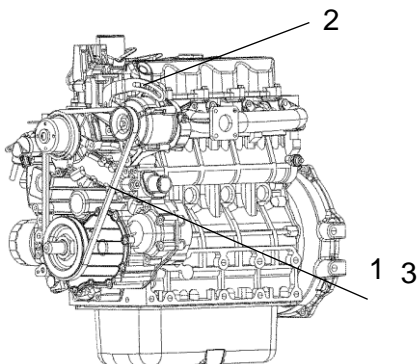

Fig. Diesel engine - V2403-M (R96 & CS IV)

- 1. Belt
- 2. Bolt and nut
- 3. Deflection between 7 to 9 mm (0.28 to 0.35 in.)

Checking - Diesel engine valve clearance

Contact your local Kubota representative for this service



Coolers

Checking - Cleaning

Make sure that the air flow through the coolers (1) and (2) is unobstructed. Dirty coolers are blown clean with compressed air or washed clean using a high-pressure water cleaner.

Blow air or direct water through the cooler in the opposite direction to that of the cooling air.

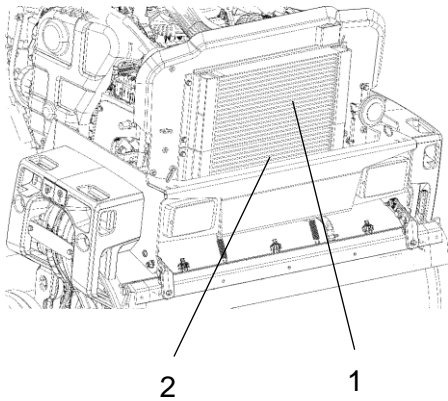

Fig. Engine compartment (CC1200/C VI)

1. Water cooler
2. Hydraulic fluid cooler



Take care when using a high-pressure water jet. Do not hold the nozzle too near the cooler.



Wear protective goggles when working with compressed air or high-pressure water jets.

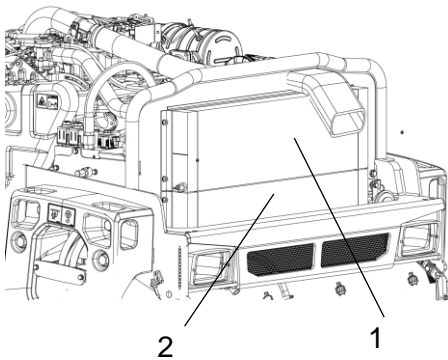
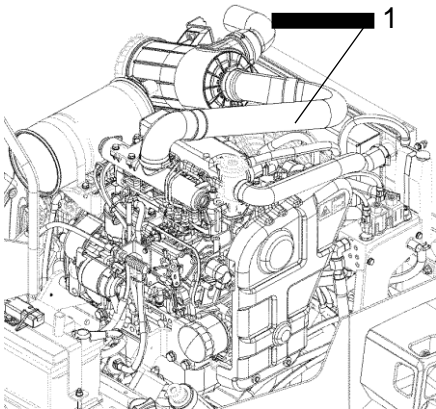

Fig. Engine compartment (CC1300/C VI - CC1400/C VI)

1. Radiator
2. Hydraulic fluid cooler

Check - Air intake hoses

Check that all hoses/hose connections are intact and tight.



**Fig. Engine compartment -
D1703-M-DI-E4B (Tier 4f, CS IV)**
1. Air intake hoses

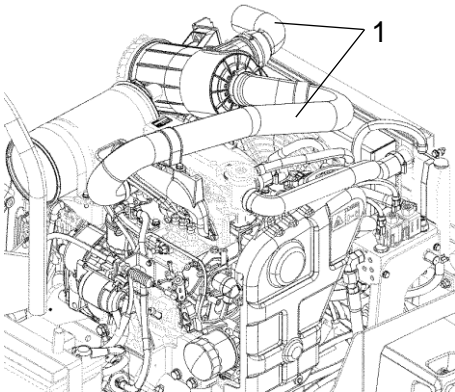

**Fig. Engine compartment -
D1703-M-IDI-E3 (Stage IIIA)**
1. Air intake hoses

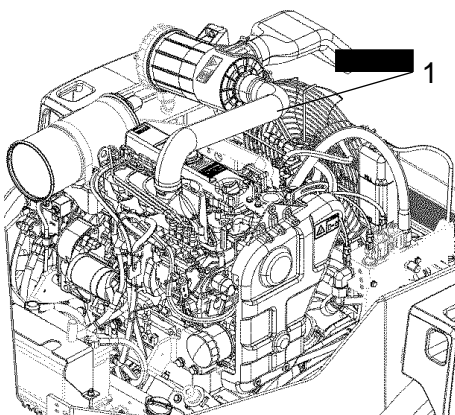

**Fig. Engine compartment - V2403-
M-DI-E3B(R96 & CS IV)**
1. Air intake hoses

Maintenance - 2000h

Performed after 2000 operating hours (every two years)



Park the roller on a level surface. The engine must be switched off and the parking brake activated when checking or adjusting the roller, unless otherwise specified.



Ensure that there is good ventilation (air extraction) if the engine is run indoors. Risk of carbon monoxide poisoning.

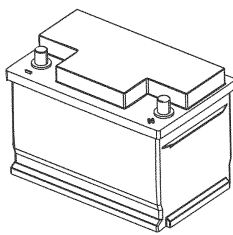

Fig. Battery

Battery - Check condition

The battery is sealed and maintenance-free.



Make sure there is no open flame in the vicinity when checking the electrolyte level. Explosive gas is formed when the alternator charges the battery.



When disconnecting the battery, always disconnect the negative cable first. When connecting the battery, always connect the positive cable first.

The cable shoes should be clean and well-tightened. Corroded cable shoes should be cleaned and greased with acid-free Vaseline.

Wipe the top of the battery.



Engine oil and oil filter - Change

Run the engine until it is warm before draining the oil .

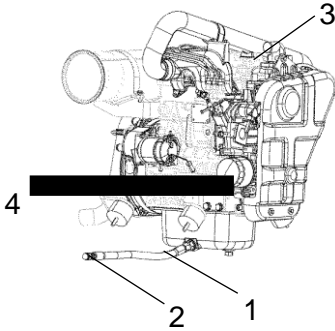

Fig. Engine compartment right side - D1703-E3B (Stage IIIA)

- 1. Drain hose
- 2. Drain plug
- 3. Filler cap
- 4. Oil filter



Switch off the engine and push in the emergency stop.



Take great care when draining fluids and oils. Wear protective gloves and goggles.

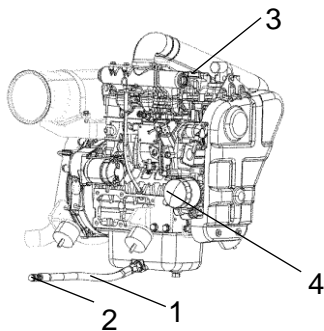

Fig. Engine compartment, right side - D1703-E4B (Tier 4f / CS IV)

- 1. Drainage hose
- 2. Drain plug
- 3. Filler cap
- 4. Oil filter

Place a receptacle that holds at least 12 liters (8 gal.) under the drain plug (2).

Undo the oil filler cap (3), and undo the drain plug (2) in the end of the drain hose (1). Let all the engine oil flow out.



Deliver the drained oil to special waste handling.



Refer to the engine manual for detailed instructions when changing oil and filters.

Remove the oil filter (4).

Collect any spillage.

Install the new filter.

Fit the drain plug (2) to the end of the hose.

Fill with fresh engine oil. See under the heading lubricants, for the correct oil grade. Fit the filler cap (3) and check that the oil level is correct using the dipstick.

Start the engine and allow it to idle for a few minutes. During this time, check around the oil filter and drain plug for leaks.

Switch off the engine, wait for a minute or so and then check the oil level. Top up with more oil if necessary.

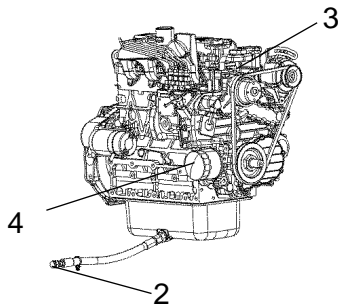

**Fig. Engine compartment right side -
V2403-M-DI-E3B(R96 & CS IV)**

- 2. Drain plug**
- 3. Filler cap**
- 4. Oil filter**

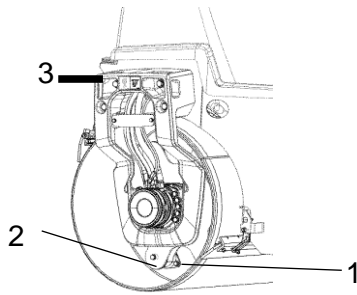

Fig. Drum end
1. Rubber element
2. Fastening screws
3. Bolted joints

Rubber elements and bolted joints Check

Check all rubber elements (1). Replace all elements where more than 25% of the elements on one side of the drum have cracks deeper than 10-15 mm (0.4-0.6 in).

Check using a knife blade or pointed object.

Check also that the attachment screws (2) are tightened.

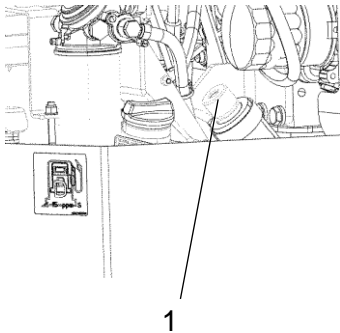

Fig. Engine compartment
1. Tank cap, hydraulic fluid

Hydraulic reservoir cap - Check

Screw off the tank cap (1) and check that it is not clogged. Air must have unobstructed passage through the cap in both directions.

If clogged in either direction, clean with a little diesel oil and blow with compressed air until free passage is assured or replace the cap with a new one.



Wear protective goggles when working with compressed air.



Steering cylinder and steering joint - Lubrication

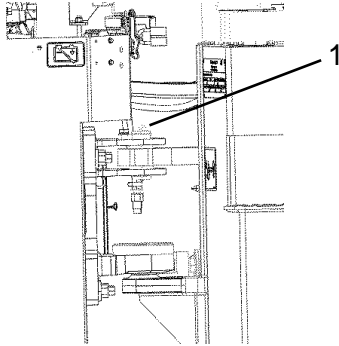

The machine must be in neutral (straight) when lubricated. All five grease nipples (1) can now be accessed.

Wipe the grease nipples (1). Grease each nipple with five strokes of the hand-operated grease gun. Make sure that grease penetrates into the bearing. If grease does not penetrate the bearings, it may be necessary to relieve the articulation joint with a jack while repeating the greasing process.

Fig. Articulation (CC1200/C VI)
1. Lubricant nipples



Do not allow anyone to remain in the vicinity of the steering joint when the engine is running. Danger of crush injury when the steering is operated. Activate the parking brake before lubricating.

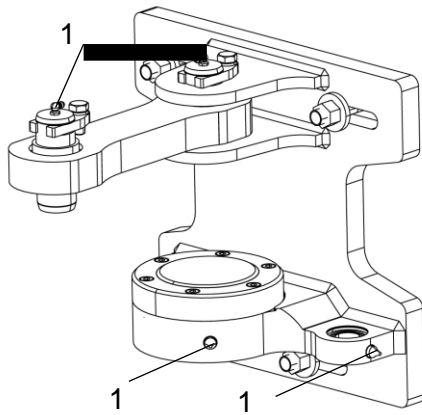

Fig. Articulated joint (CC1300/C VI - CC1400/C VI)
1. Lubricant nipples

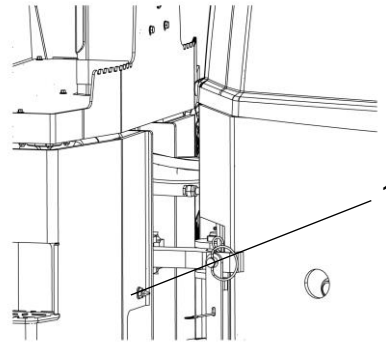
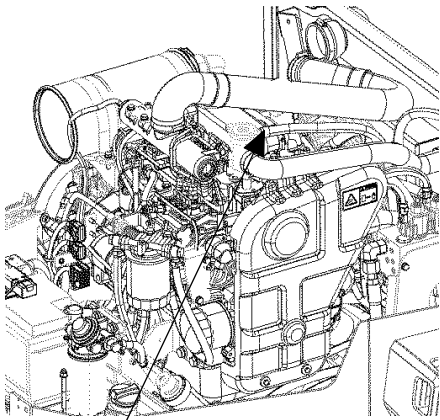

Fig. Rear frame
1. Lubrication nipple



Check - Coolant system



1

**Fig. Cooling water container
(CC1200/C VI)**
1. Filler cap

Check that all hoses/hose connectors are intact and tight. Fill with coolant as specified in the lubricants specification.



Take great care when opening the radiator cap while the engine is hot. Wear protective gloves and goggles.



Also check the freezing point. Change the coolant every other year.

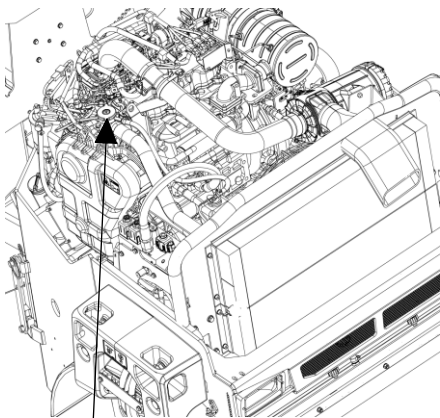

1

**Fig. Cooling water container
(CC1300/C VI - CC1400/C VI)**
1. Filler cap



Air cleaner Check - Replacement of main filter



Replace the air cleaner's main filter when the indicator shows red. The indicator is located on the filter, or in its immediate vicinity.

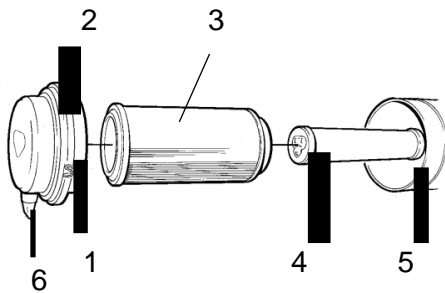

Fig. Air cleaner
 1. Clips
 2. Cover
 3. Main filter
 4. Backup filter
 5. Filter housing
 6. Dust valve

Release the clips (1), pull off the cover (2), and pull out the main filter (3).

Do not remove the backup filter (4).

Clean the air cleaner if necessary, see section Air cleaner - Cleaning.

When replacing the main filter (3), insert a new filter and refit the air cleaner in the reverse order.

Check the condition of the dust valve (6); replace if necessary.

When refitting the cover, make sure that the dust valve is positioned downwards.

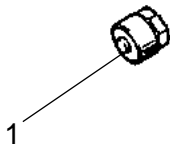

Fig. Indicator
 1. Button

Air filter indicator - Resetting

The air filter indicator is located on the filter, or in its immediate vicinity.

The air filter indicator must be reset after replacing the air filter.

Press the "button" (1) on the top of the indicator to reset.



Backup filter - Change

Change the backup filter with a new filter after every third replacement of the main filter.

To change the backup filter (1), pull the old filter out of its holder, insert a new filter and reassemble the air cleaner in the reverse order.

Clean the air cleaner if necessary, see section Air cleaner - Cleaning.

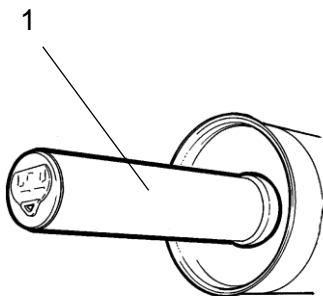

Fig. Air filter
 1. Backup filter



Replacing the hydraulic oil filter

Open the engine hood.

Loosen the red cap (1) and pull up the filter insert (4).

Refit the red cap temporarily to prevent dust and dirt getting into the tank.

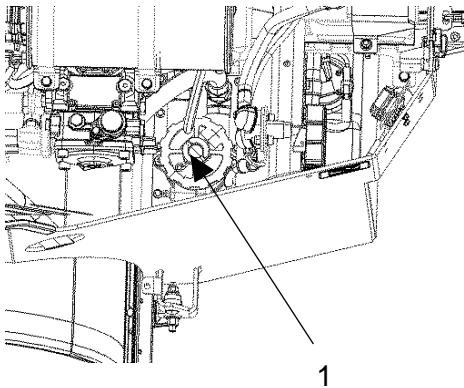

Fig. Engine compartment
1. Filler cap

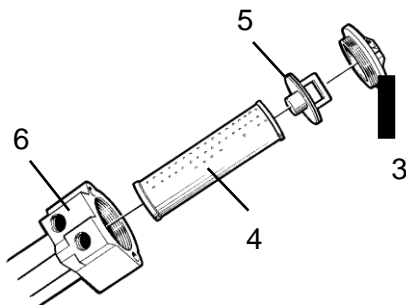

Fig. Hydraulic oil filter
3. Cap
4. Filter insert
5. Handle
6. Filter holder

Release the filter insert (4) from the handle (5).



Remove the filter (4) and hand in to a waste disposal site. This is a disposable filter and cannot be cleaned.

Mount the new insert on the handle, refit the unit into the filter holder (6), and refit the red cover.

Start the engine and allow it to run at full revs for 30 seconds. Check that the filter cap (3) is tight.



Replacing the fuel filter

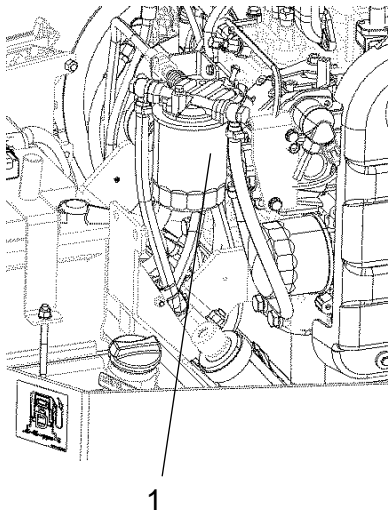

Fig. Engine compartment, right side
1. Fuel filter



Place a container underneath to collect fuel that runs out when the filter is released.

Screw off the fuel filter (1). The filter is of the disposable type and cannot be cleaned. Hand in to a waste disposal site.

Install the new filter.

Start the engine and check that the fuel filter is tight.



Refer to the engine manual for detailed instructions when replacing the fuel filter.



Ensure good ventilation (air extraction) if the diesel engine is run indoors. Risk of carbon monoxide poisoning.



Replacing the pre-filter

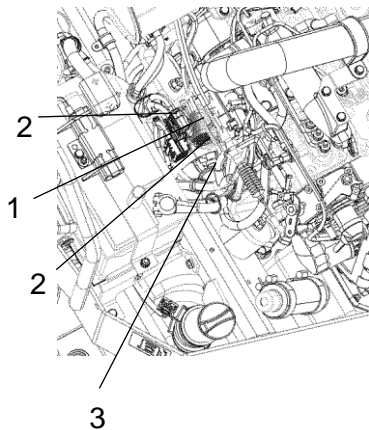

Fig. Engine compartment -
D1703-M-IDI-E3 (Stage IIIA) /
V2403-M-DI-E3B(R96 & CS
IV)

1. Pre-filter
2. Hose clamps
3. Fuel pump

Activate the parking brake.
Switch off the engine and open the engine hood.



Place a container underneath to collect fuel that runs out when the filter is released.

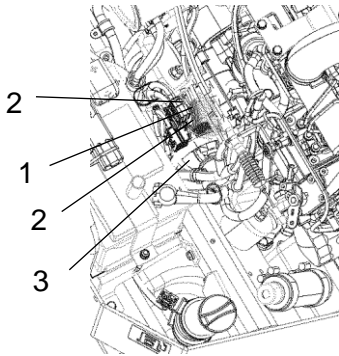

**Fig. Engine compartment -
D1703-M-DI-E4B (Tier 4f / CS IV)**
1. Pre-filter
2. Hose clamps
3. Fuel pump

D1703 / V2403-M-DI-E3B(R96 & CS IV)

The prefilter is located to the left of the fuel pump in the engine compartment.

Loosen the hose clamps (2) using a screwdriver.

Remove the pre-filter (1) and hand in to a waste disposal site. This is a disposable filter and cannot be cleaned.

Fit a new pre-filter and tighten the hose clamps.

Start the engine and check that the pre-filter is tight.



Ensure good ventilation (air extraction) if the diesel engine is run indoors. Risk of carbon monoxide poisoning.



Fuel tank - Cleaning

It is easiest to clean the tank when it is almost empty.



Pump out any bottom sediment using a suitable pump, such as an oil drain pump. Save the oil in a container and dispose of it in an approved manner.



Keep in mind fire risk when handling fuel.



The fuel tank is made of plastic (polyethylene) and is recyclable.

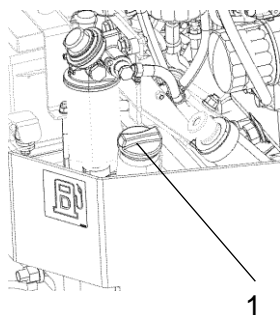

Fig. Fuel tank
1. Fuel tank



Coolers Checking - Cleaning

Make sure that the air flow through the coolers (1) and (2) is unobstructed. Dirty coolers are blown clean with compressed air or washed clean using a high-pressure water cleaner.

Blow air or direct water through the cooler in the opposite direction to that of the cooling air.

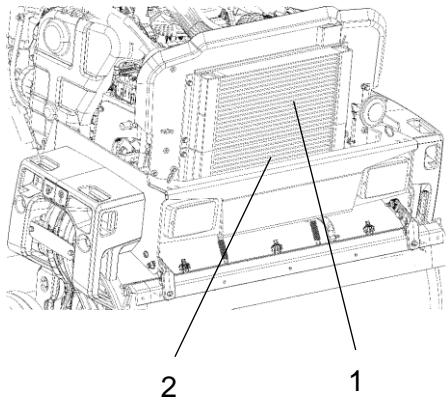

Fig. Engine compartment (CC1200/C VI)

1. Water cooler
2. Hydraulic fluid cooler



Take care when using a high-pressure water jet. Do not hold the nozzle too near the cooler.



Wear protective goggles when working with compressed air or high-pressure water jets.

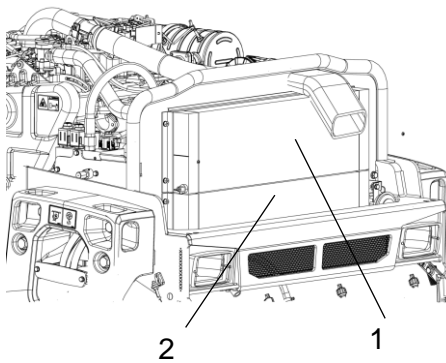

Fig. Engine compartment (CC1300/C VI - CC1400/C VI)

1. Radiator
2. Hydraulic fluid cooler



Water tank - Draining



Remember that there is a risk of freezing during the winter. Empty the tank, pump and lines.

Remove the drain plug (1) and allow all the water to run out. Wipe clean the drain plug and screw back in.

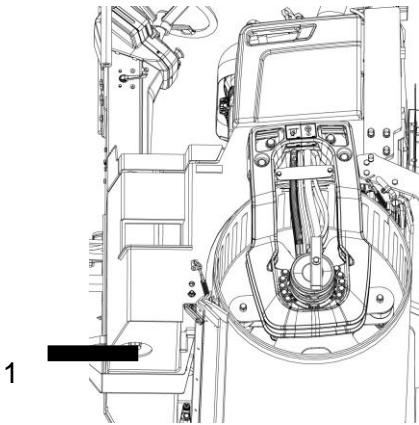

Fig. Water tank
1. Drain plug



Water tank - Cleaning

Clean the tank with water and a suitable detergent for plastic surfaces.

Refit the filter housing or the drain plug (1). Fill with water and check for leaks.



The water tank is made of plastic (polyethylene) and are recyclable.

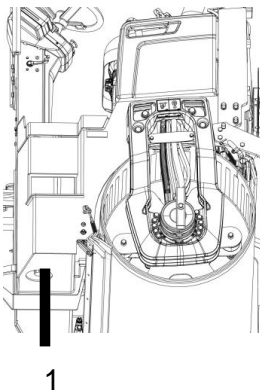

Fig. Water tank
1. Drain plug

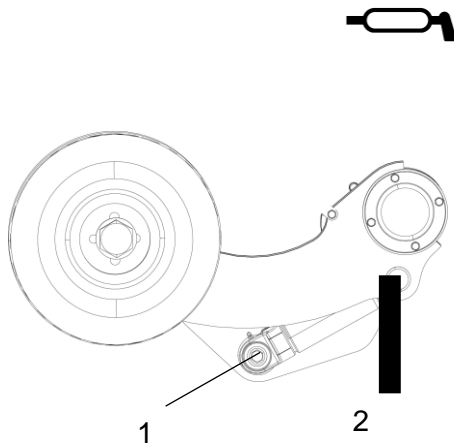

Fig. Two grease points for lubricating the edge cutter

Edge cutter (Optional) - Lubrication



Refer to the operation section for information on how to operate the edge cutter.

Grease the two points as shown in the figure.

Grease should always be used for lubrication, see the lubricant specifications.

Grease all bearing points with five strokes of a hand-operated grease gun.



Hydraulic reservoir - fluid change

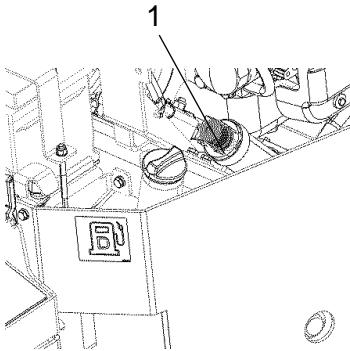

Fig. Hydraulic reservoir
1. Draining

Use an external drainage pump when draining/emptying the hydraulic reservoir.



Risk of burn injuries when draining hot oil. Wear protective gloves and goggles.

Unscrew the tank cap. Place the pump's suction hose in the filler/drain outlet in the hydraulic tank. Place the other hose in a container.



Use a receptacle that holds at least 42 liters (11 gal).

Start the pump so that it sucks out the fluid from the tank.

Check that the hose to the pump reaches the bottom of the hydraulic reservoir to ensure that as much of the fluid as possible is drained.



Collect the oil and deliver to special waste handling.

Fill up with the recommended hydraulic fluid to the correct level. Replace the cap on the tank and wipe clean.

Change the hydraulic fluid filter, see under heading 'Every 1000 hours of operation'.

Start the engine and operate the various hydraulic functions. Check the level in the reservoir and top off as required.



Drum - Oil change



Take great care when draining the fluid. Wear protective gloves and goggles.

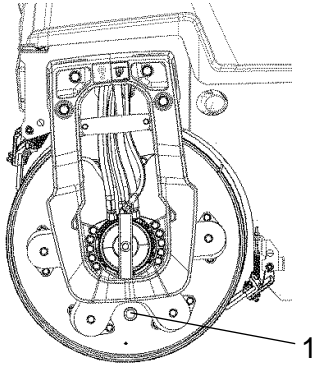

Fig. Drum, vibration side
1. Drain plug

Place the roller on a level surface and drive it slowly until the drain plug (1) is straight down.

- Remove the oil plug (1) and allow all the oil to run out.
- Clean and refit the oil plugs (1).
- Start the machine and run until the oil plug (1) is positioned straight up.
- Remove the oil plug (1) and fill the drum with the right quantity and the type of oil according to the lubricant table.
- Refit the oil plug (1).
- Run the machine until the drum's oil plug comes in the right position to check the level.
- Loosen the plug and check the level.



Switch off the engine and activate the parking brake.



Place a receptacle that will hold at least 15 liters (15.9 quarts) under the plug. Collect the oil and dispose of it properly.

Checking - Diesel engine valve clearance

Contact your local Kubota representative for this service

Replacing belts/Checking the belt tension

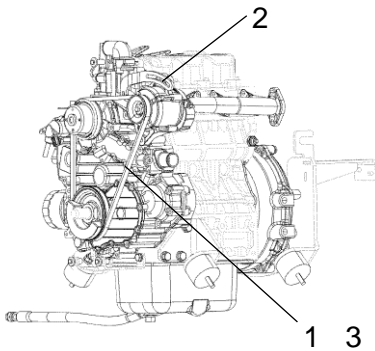

Fig. Diesel engine - D1703 (Tier 4f, CS IV)

- 1. Belt
- 2. Bolt and nut
- 3. Deflection between 7 to 9 mm (0.28 to 0.35 in.)



Exercise care to stop the engine and remove the key before checking the belt tension.



Exercise care to install the standalone safety shield after maintenance or inspection.

Stop the engine and remove the key.

If necessary, remove the belt guard.

Apply a moderate pressure with your thumb on the belt, between the belt pulleys on the alternator and crankshaft, to check the belt tension. The deflection should be between 7 and 9 mm (0.28 to 0.35 in.).

If the belt tension is not sufficient: - Loosen the fastening bolts that hold the alternator in place. - Use a prybar/lever and place it between the alternator and engine block, push the alternator outwards to achieve the required belt tension.

Tighten the bolts holding the alternator with the correct torque.



If the belt is loose or damaged, it may result in insufficient charging. Adjust or replace the belt.

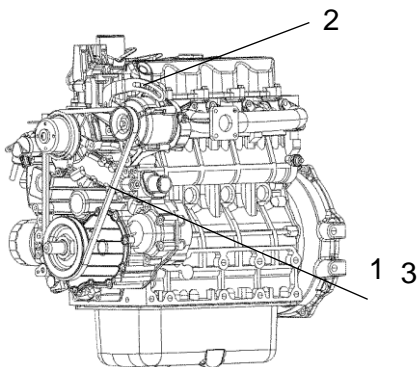

Fig. Diesel engine - V2203-M (Stage IIIA)

- 1. Belt
- 2. Bolt and nut
- 3. Deflection between 7 to 9 mm (0.28 to 0.35 in.)

Steering joint - Check

Check the steering joint for any damage or cracks.

Check and tighten any loose bolts.

Check also for any stiffness and play.

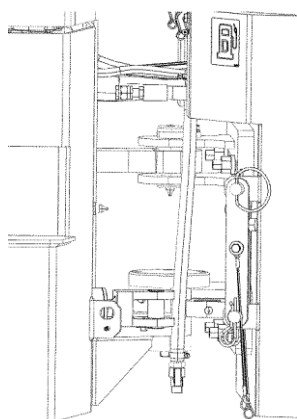

Fig. Steering joint

Maintenance, 3000h

Park the roller on a level surface. The engine must be switched off and the parking brake activated when checking or adjusting the roller, unless otherwise specified.



Ensure that there is good ventilation (air extraction) if the engine is run indoors. Risk of carbon monoxide poisoning.

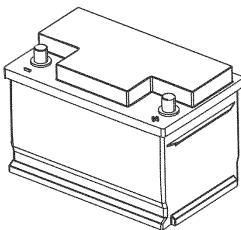

Fig. Battery

Battery
- Check condition

The battery is sealed and maintenance-free.



Make sure there is no open flame in the vicinity when checking the electrolyte level. Explosive gas is formed when the alternator charges the battery.



When disconnecting the battery, always disconnect the negative cable first. When connecting the battery, always connect the positive cable first.

The cable shoes should be clean and well-tightened. Corroded cable shoes should be cleaned and greased with acid-free Vaseline.

Wipe the top of the battery.



Engine oil and oil filter - Change

Run the engine until it is warm before draining the oil .

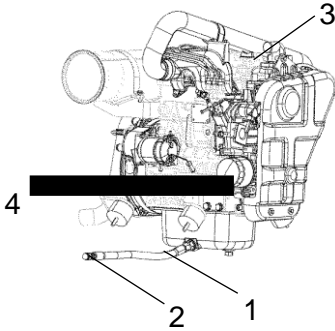

Fig. Engine compartment right side - D1703-E3B (Stage IIIA)

- 1. Drain hose
- 2. Drain plug
- 3. Filler cap
- 4. Oil filter



Switch off the engine and push in the emergency stop.



Take great care when draining fluids and oils. Wear protective gloves and goggles.

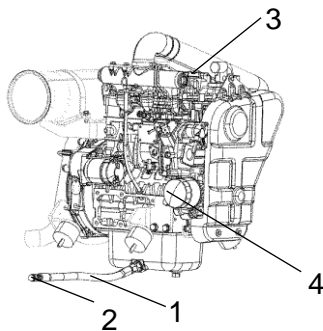

Fig. Engine compartment, right side - D1703-E4B (Tier 4f / CS IV)

- 1. Drainage hose
- 2. Drain plug
- 3. Filler cap
- 4. Oil filter

Place a receptacle that holds at least 12 liters (8 gal.) under the drain plug (2).

Undo the oil filler cap (3), and undo the drain plug (2) in the end of the drain hose (1). Let all the engine oil flow out.



Deliver the drained oil to special waste handling.



Refer to the engine manual for detailed instructions when changing oil and filters.

Remove the oil filter (4).

Collect any spillage.

Install the new filter.

Fit the drain plug (2) to the end of the hose.

Fill with fresh engine oil. See under the heading lubricants, for the correct oil grade. Fit the filler cap (3) and check that the oil level is correct using the dipstick.

Start the engine and allow it to idle for a few minutes. During this time, check around the oil filter and drain plug for leaks.

Switch off the engine, wait for a minute or so and then check the oil level. Top up with more oil if necessary.

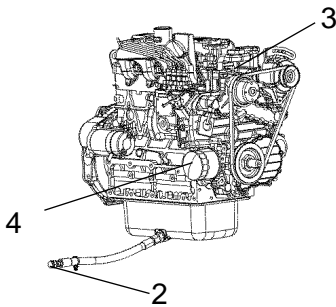

**Fig. Engine compartment right side -
V2403-M-DI-E3B(R96 & CS IV)**

- 2. Drain plug**
- 3. Filler cap**
- 4. Oil filter**



Drum - oil level Inspection - filling

Run the roller slowly until the oil plug (1) is positioned as illustrated.

Make sure that the marking (2) on the drum end faces downward before starting work.

Unscrew the plug and check that the oil level reaches up to the bottom of the hole. Top up with new oil if necessary. Use oil as per the lubricant specification.

Clean the magnetic oil plug (1) from any metallic residue, and refit the plug.

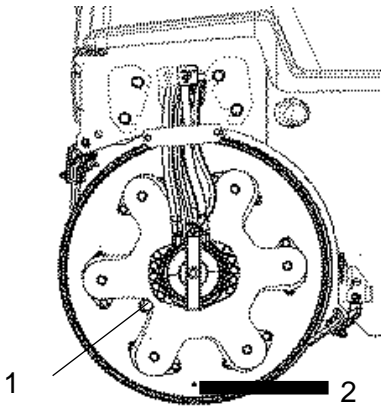

Fig. Drum, vibration side (CC1200/C VI)
1. Oil drain plug
2. Marking on the drum end

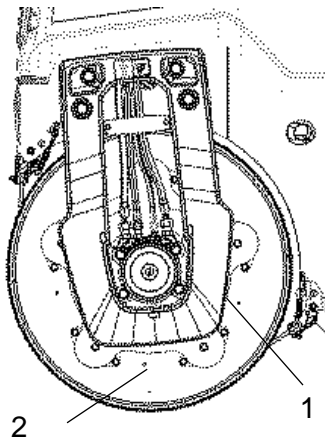

Fig. Drum vibration side (CC1300/C VI - CC1400/C VI)
1. Oil drain plug
2. Marking on the drum end

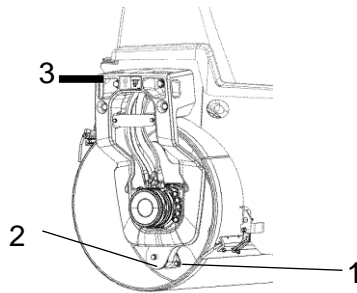

Fig. Drum end
1. Rubber element
2. Fastening screws
3. Bolted joints

Rubber elements and bolted joints Check

Check all rubber elements (1). Replace all elements where more than 25% of the elements on one side of the drum have cracks deeper than 10-15 mm (0.4-0.6 in).

Check using a knife blade or pointed object.

Check also that the attachment screws (2) are tightened.

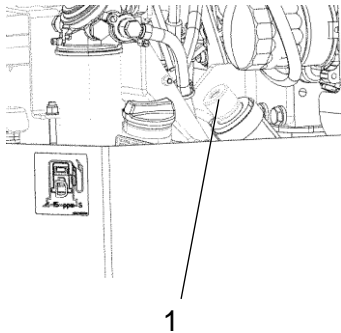

Fig. Engine compartment
1. Tank cap, hydraulic fluid

Hydraulic reservoir cap - Check

Screw off the tank cap (1) and check that it is not clogged. Air must have unobstructed passage through the cap in both directions.

If clogged in either direction, clean with a little diesel oil and blow with compressed air until free passage is assured or replace the cap with a new one.



Wear protective goggles when working with compressed air.



Steering cylinder and steering joint - Lubrication

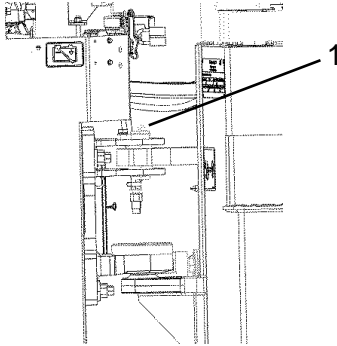

The machine must be in neutral (straight) when lubricated. All five grease nipples (1) can now be accessed.

Wipe the grease nipples (1). Grease each nipple with five strokes of the hand-operated grease gun. Make sure that grease penetrates into the bearing. If grease does not penetrate the bearings, it may be necessary to relieve the articulation joint with a jack while repeating the greasing process.

Fig. Articulation (CC1200/C VI)
1. Lubricant nipples



Do not allow anyone to remain in the vicinity of the steering joint when the engine is running. Danger of crush injury when the steering is operated. Activate the parking brake before lubricating.

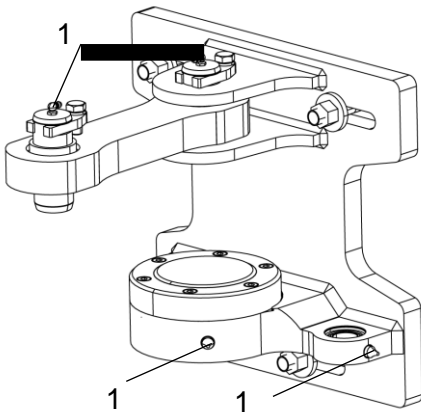

Fig. Articulated joint (CC1300/C VI - CC1400/C VI)
1. Lubricant nipples

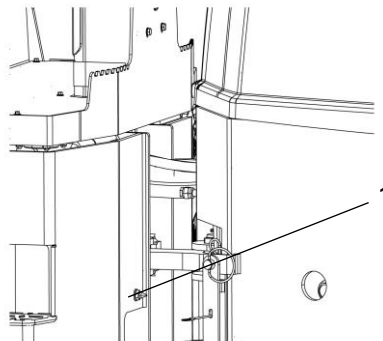
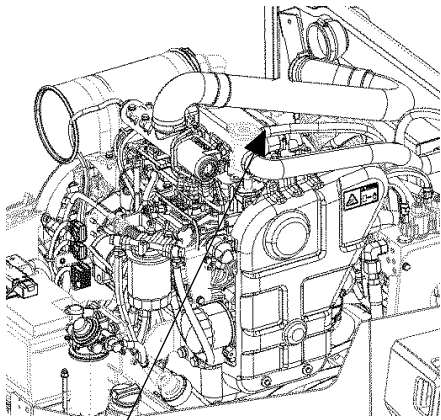

Fig. Rear frame
1. Lubrication nipple



Check - Coolant system



1

**Fig. Cooling water container
(CC1200/C VI)**
1. Filler cap

Check that all hoses/hose connectors are intact and tight. Fill with coolant as specified in the lubricants specification.



Take great care when opening the radiator cap while the engine is hot. Wear protective gloves and goggles.



Also check the freezing point. Change the coolant every other year.

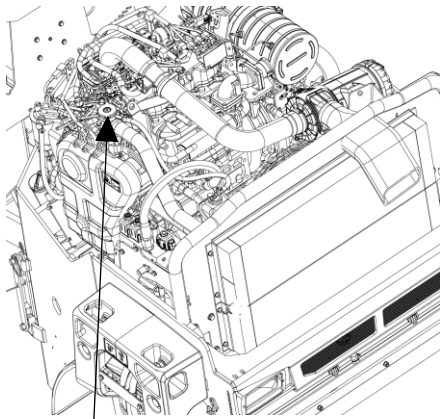

1

**Fig. Cooling water container
(CC1300/C VI - CC1400/C VI)**
1. Filler cap



Air cleaner Check - Replacement of main filter



Replace the air cleaner's main filter when the indicator shows red. The indicator is located on the filter, or in its immediate vicinity.

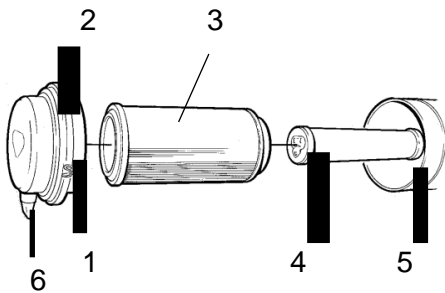

Fig. Air cleaner
 1. Clips
 2. Cover
 3. Main filter
 4. Backup filter
 5. Filter housing
 6. Dust valve

Release the clips (1), pull off the cover (2), and pull out the main filter (3).

Do not remove the backup filter (4).

Clean the air cleaner if necessary, see section Air cleaner - Cleaning.

When replacing the main filter (3), insert a new filter and refit the air cleaner in the reverse order.

Check the condition of the dust valve (6); replace if necessary.

When refitting the cover, make sure that the dust valve is positioned downwards.

Air filter indicator - Resetting

The air filter indicator is located on the filter, or in its immediate vicinity.

The air filter indicator must be reset after replacing the air filter.

Press the "button" (1) on the top of the indicator to reset.

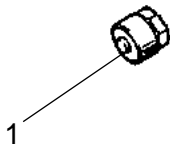

Fig. Indicator
 1. Button



Backup filter - Change

Change the backup filter with a new filter after every third replacement of the main filter.

To change the backup filter (1), pull the old filter out of its holder, insert a new filter and reassemble the air cleaner in the reverse order.

Clean the air cleaner if necessary, see section Air cleaner - Cleaning.

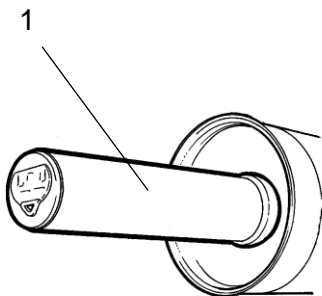

Fig. Air filter
 1. Backup filter



Replacing the hydraulic oil filter

Open the engine hood.

Loosen the red cap (1) and pull up the filter insert (4).

Refit the red cap temporarily to prevent dust and dirt getting into the tank.

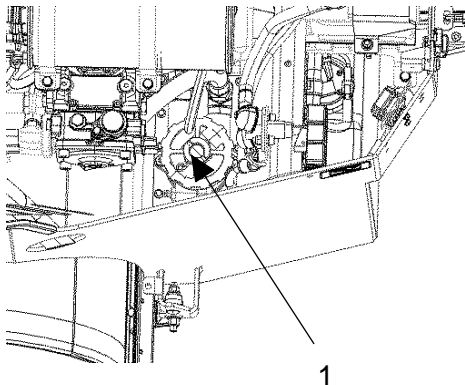

Fig. Engine compartment
1. Filler cap

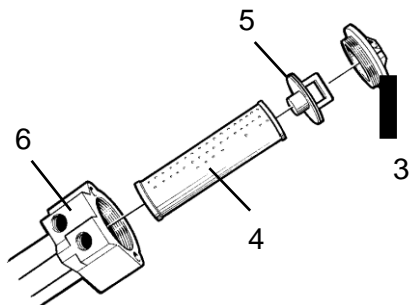

Fig. Hydraulic oil filter
3. Cap
4. Filter insert
5. Handle
6. Filter holder

Release the filter insert (4) from the handle (5).



Remove the filter (4) and hand in to a waste disposal site. This is a disposable filter and cannot be cleaned.

Mount the new insert on the handle, refit the unit into the filter holder (6), and refit the red cover.

Start the engine and allow it to run at full revs for 30 seconds. Check that the filter cap (3) is tight.



Replacing the fuel filter



Place a container underneath to collect fuel that runs out when the filter is released.

Screw off the fuel filter (1). The filter is of the disposable type and cannot be cleaned. Hand in to a waste disposal site.

Install the new filter.

Start the engine and check that the fuel filter is tight.



Refer to the engine manual for detailed instructions when replacing the fuel filter.



Ensure good ventilation (air extraction) if the diesel engine is run indoors. Risk of carbon monoxide poisoning.

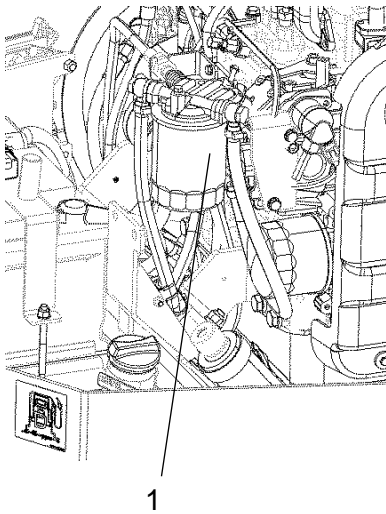

Fig. Engine compartment, right side
1. Fuel filter



Replacing the pre-filter

Activate the parking brake.

Switch off the engine and open the engine hood.



Place a container underneath to collect fuel that runs out when the filter is released.

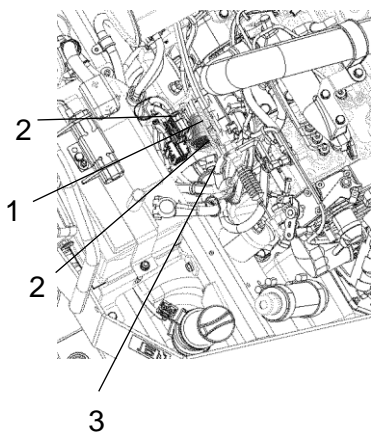
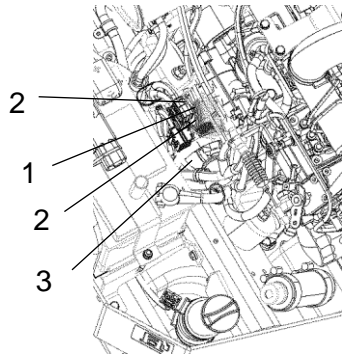

Fig. Engine compartment -
D1703-M-IDI-E3 (Stage IIIA) /
V2403-M-DI-E3B(R96 & CS
IV)

1. Pre-filter
2. Hose clamps
3. Fuel pump



**Fig. Engine compartment -
D1703-M-DI-E4B (Tier 4f / CS IV)**
1. Pre-filter
2. Hose clamps
3. Fuel pump

D1703 / V2403-M-DI-E3B(R96 & CS IV)

The prefilter is located to the left of the fuel pump in the engine compartment.

Loosen the hose clamps (2) using a screwdriver.

Remove the pre-filter (1) and hand in to a waste disposal site. This is a disposable filter and cannot be cleaned.

Fit a new pre-filter and tighten the hose clamps.

Start the engine and check that the pre-filter is tight.



Ensure good ventilation (air extraction) if the diesel engine is run indoors. Risk of carbon monoxide poisoning.



Fuel tank - Cleaning

It is easiest to clean the tank when it is almost empty.



Pump out any bottom sediment using a suitable pump, such as an oil drain pump. Save the oil in a container and dispose of it in an approved manner.



Keep in mind fire risk when handling fuel.



The fuel tank is made of plastic (polyethylene) and is recyclable.

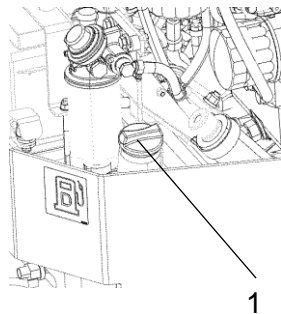
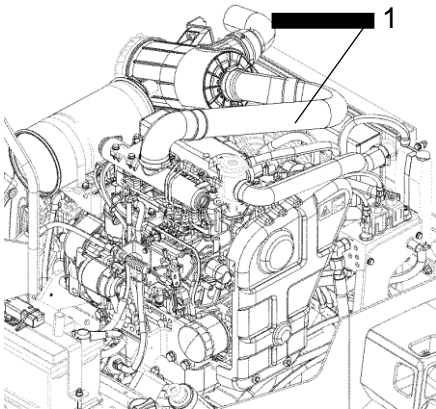

Fig. Fuel tank
1. Fuel tank

Check - Air intake hoses

Check that all hoses/hose connections are intact and tight.



**Fig. Engine compartment -
D1703-M-DI-E4B (Tier 4f, CS IV)**
1. Air intake hoses

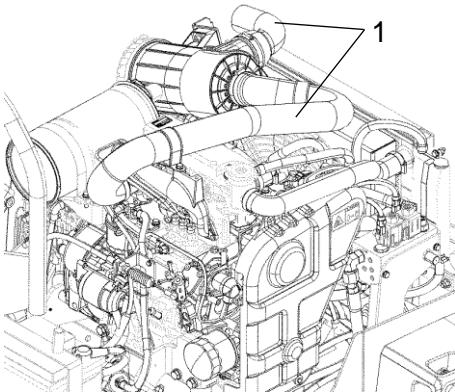

**Fig. Engine compartment -
D1703-M-IDI-E3 (Stage IIIA)**
1. Air intake hoses

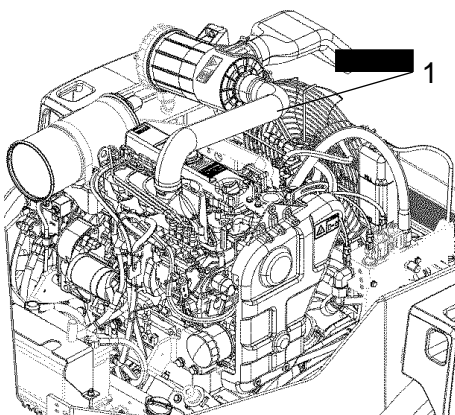

**Fig. Engine compartment - V2403-
M-DI-E3B(R96 & CS IV)**
1. Air intake hoses



Coolers Checking - Cleaning

Make sure that the air flow through the coolers (1) and (2) is unobstructed. Dirty coolers are blown clean with compressed air or washed clean using a high-pressure water cleaner.

Blow air or direct water through the cooler in the opposite direction to that of the cooling air.

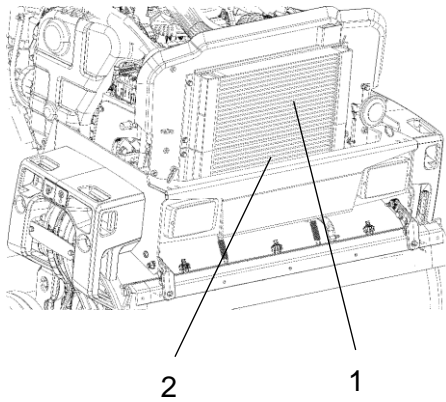

Fig. Engine compartment (CC1200/C VI)

- 1. Water cooler
- 2. Hydraulic fluid cooler



Take care when using a high-pressure water jet. Do not hold the nozzle too near the cooler.



Wear protective goggles when working with compressed air or high-pressure water jets.

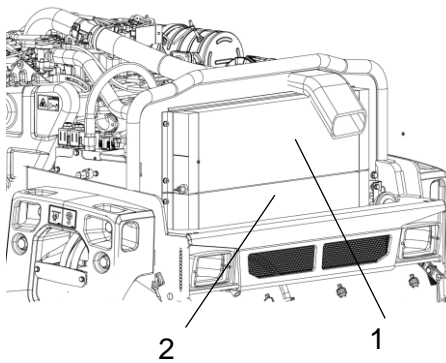

Fig. Engine compartment (CC1300/C VI - CC1400/C VI)

- 1. Radiator
- 2. Hydraulic fluid cooler



Water tank - Draining



Remember that there is a risk of freezing during the winter. Empty the tank, pump and lines.

Remove the drain plug (1) and allow all the water to run out. Wipe clean the drain plug and screw back in.

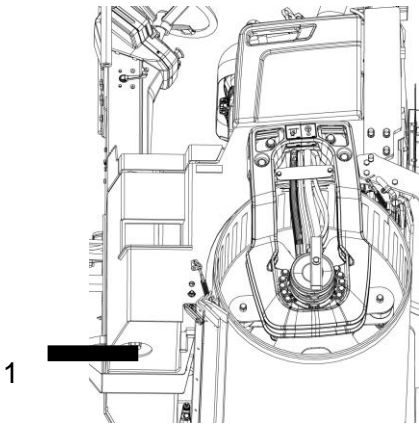

Fig. Water tank
1. Drain plug



Water tank - Cleaning

Clean the tank with water and a suitable detergent for plastic surfaces.

Refit the filter housing or the drain plug (1). Fill with water and check for leaks.



The water tank is made of plastic (polyethylene) and are recyclable.

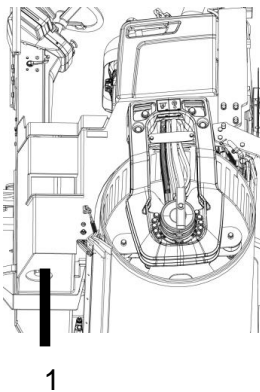

Fig. Water tank
1. Drain plug

Checking - Diesel engine valve clearance

Contact your local Kubota representative for this service



Hydraulic reservoir - fluid change

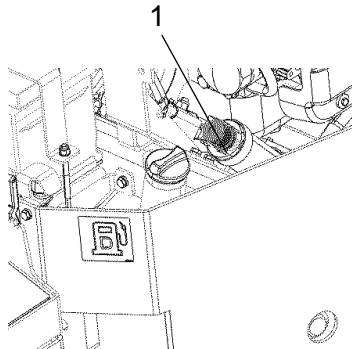

Fig. Hydraulic reservoir
1. Draining

Use an external drainage pump when draining/emptying the hydraulic reservoir.



Risk of burn injuries when draining hot oil. Wear protective gloves and goggles.

Unscrew the tank cap. Place the pump's suction hose in the filler/drain outlet in the hydraulic tank. Place the other hose in a container.



Use a receptacle that holds at least 42 liters (11 gal).

Start the pump so that it sucks out the fluid from the tank.

Check that the hose to the pump reaches the bottom of the hydraulic reservoir to ensure that as much of the fluid as possible is drained.



Collect the oil and deliver to special waste handling.

Fill up with the recommended hydraulic fluid to the correct level. Replace the cap on the tank and wipe clean.

Change the hydraulic fluid filter, see under heading 'Every 1000 hours of operation'.

Start the engine and operate the various hydraulic functions. Check the level in the reservoir and top off as required.

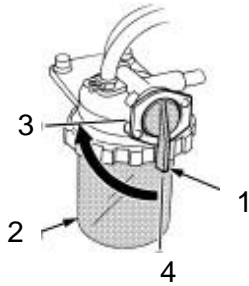

Fig. Fuel filter
1. Filter knob
2. Filter element
3. OFF
4. ON

Draining of water separator

Close the fuel filter knob (1).

Remove the top cap and rinse the inside with diesel fuel.

Remove filter element (2) and rinse the inside with diesel fuel.

After cleaning, install the fuel filter, to keep out of dust and dirt.

Air-bleed the injection pump.



Dust and dirt may cause a injection pump and nozzle failure. Wash the fuel filter cup periodically.

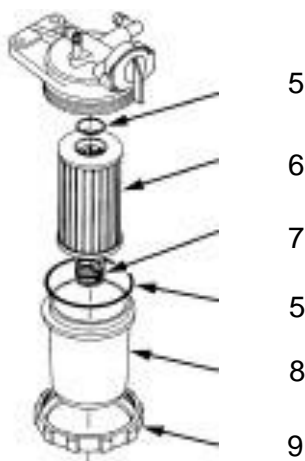

Fig. Fuel filter element
5. O-ring
6. Filter element
7. Spring
8. Filter
9. Screw ring

Replacing belts/Checking the belt tension

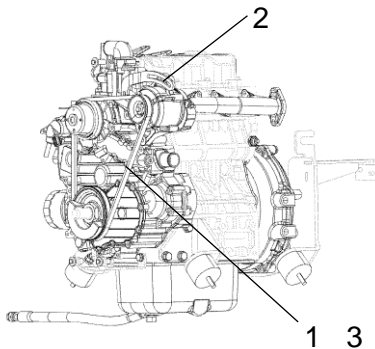

Fig. Diesel engine - D1703 (Tier 4f, CS IV)

- 1. Belt**
- 2. Bolt and nut**
- 3. Deflection between 7 to 9 mm (0.28 to 0.35 in.)**



Exercise care to stop the engine and remove the key before checking the belt tension.



Exercise care to install the standalone safety shield after maintenance or inspection.

Stop the engine and remove the key.

If necessary, remove the belt guard.

Apply a moderate pressure with your thumb on the belt, between the belt pulleys on the alternator and crankshaft, to check the belt tension. The deflection should be between 7 and 9 mm (0.28 to 0.35 in.).

If the belt tension is not sufficient: - Loosen the fastening bolts that hold the alternator in place. - Use a prybar/lever and place it between the alternator and engine block, push the alternator outwards to achieve the required belt tension.

Tighten the bolts holding the alternator with the correct torque.



If the belt is loose or damaged, it may result in insufficient charging. Adjust or replace the belt.

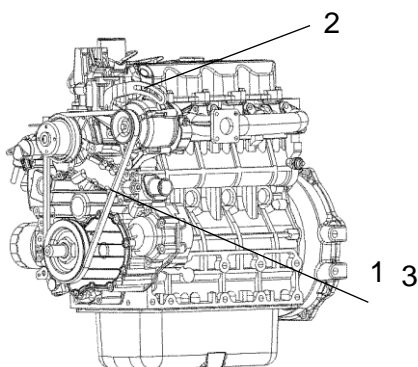

Fig. Diesel engine - V2203-M (Stage IIIA)

- 1. Belt**
- 2. Bolt and nut**
- 3. Deflection between 7 to 9 mm (0.28 to 0.35 in.)**

Checking the injection pump (D1703 and V2403-M-DI-E3B(R96 & CS IV) only)

Contact your local Kubota representative for this service

Steering joint - Check

Check the steering joint for any damage or cracks.

Check and tighten any loose bolts.

Check also for any stiffness and play.

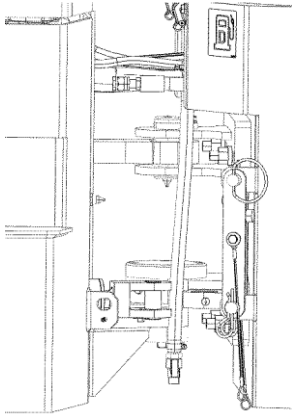

Fig. Steering joint

Maintenance, every 12th month (Annually)



Air cleaner Check - Replacement of main filter



Replace the air cleaner's main filter when the indicator shows red. The indicator is mounted on the air cleaner's connecting pipe.

Air filter indicator - Resetting

The air filter indicator is located on the filter, or in its immediate vicinity.

The air filter indicator must be reset after replacing the air filter.

Press the "button" (1) on the top of the indicator to reset.

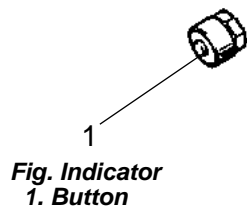

Backup filter - Change

Change the backup filter with a new filter after every third replacement of the main filter.

To change the backup filter (1), pull the old filter out of its holder, insert a new filter and reassemble the air cleaner in the reverse order.

Clean the air cleaner if necessary, see section Air cleaner - Cleaning.

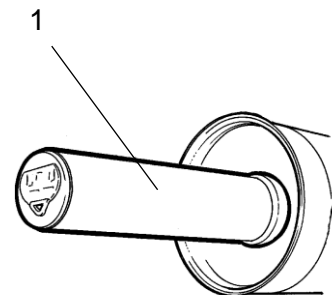

Maintenance, every 24th month (Every other year)



Check - Coolant system

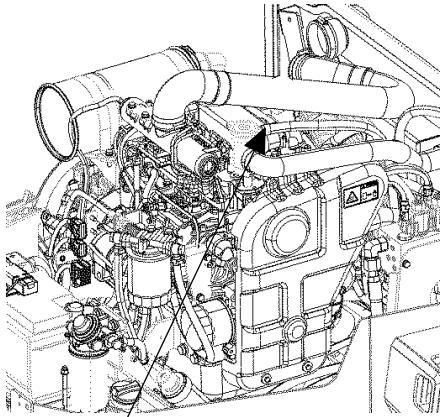

1

Fig. Cooling water container
(CC1200/C VI)
1. Filler cap

Check that all hoses/hose connectors are intact and tight. Fill with coolant as specified in the lubricants specification.



Take great care when opening the radiator cap while the engine is hot. Wear protective gloves and goggles.



Also check the freezing point. Change the coolant every other year.

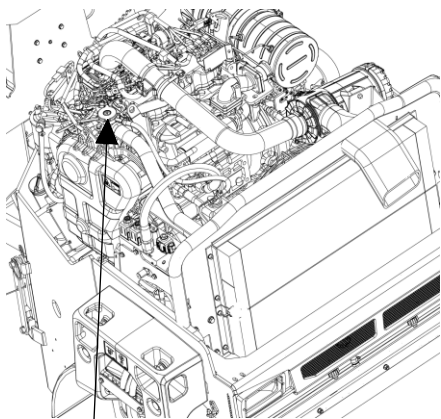

1

Fig. Cooling water container
(CC1300/C VI - CC1400/C VI)
1. Filler cap

Check - Air intake hoses

Check that all hoses/hose connections are intact and tight.

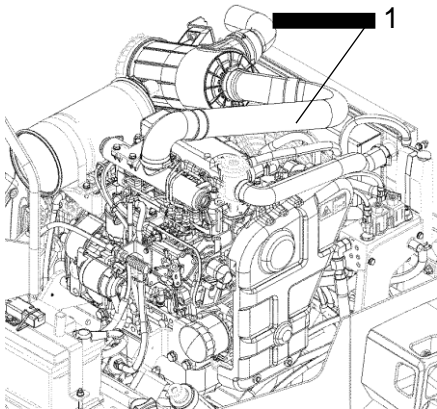

**Fig. Engine compartment -
D1703-M-DI-E4B (Tier 4f, CS IV)**
1. Air intake hoses

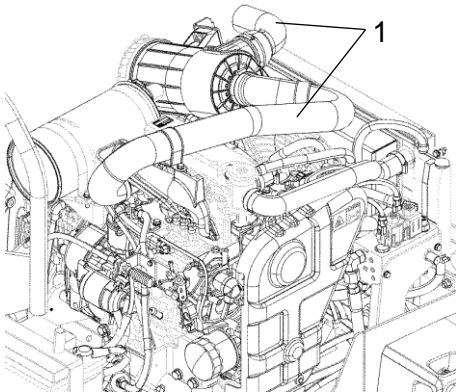

**Fig. Engine compartment -
D1703-M-IDI-E3 (Stage IIIA)**
1. Air intake hoses

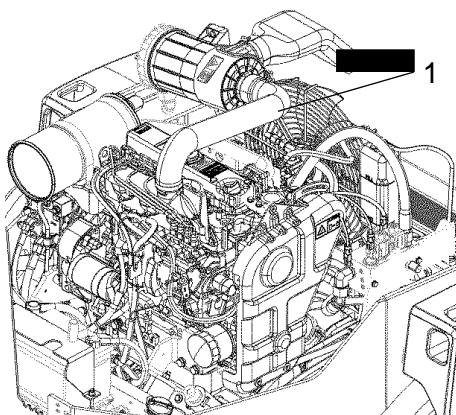

**Fig. Engine compartment - V2403-
M-DI-E3B(R96 & CS IV)**
1. Air intake hoses

