

FANQUIP

Mancooler Fans

Heavy Duty, Light Weight





Mobile Mancooler Fans

The Fanquip Mobile Mancooler Fans have fan diameters ranging from 400 mm to 1000 mm. The drum body is constructed from heavy gauge steel, flared at each end for protection. The frame is tubular steel, light but robust and fitted with pivot bolts and locking nuts on each side to allow the drum to deflect the air beam 360°. Solid rubber wheels on solid axles complete with the units. Swivel castors are also available. All fan impellers are adjustable pitch aerofoils to provide an efficient but quiet air flow.

PERFORMANCE DATA

Performance Data	Model Number	Fan Diameter mm	Motor Speed r/s	Motor Power kW	Free Air Volume l/s	*Noise Level dB(A)
	1-40241/3	400	24	0.18	1500	52
	1-40481/3	400	48	1.50	2500	74
	1-50241/3	500	24	0.55	3000	63
	1-60241/3	600	24	1.10	4400	68
	1-61241/3	600	24	2.20	5800	72
	1-80163	800	16	1.50	7000	66
	1-80241/3	800	24	2.20	8000	74
	1-10123	1000	12	3.00	12000	63
	1-10163	1000	16	5.50	17000	78

*Note: Noise level is indicative only and should only be used to indicate relative values, as actual figures depend on the situation of the fan and the relevant field conditions.

All sizes etc shown are nominal. Subject to change without notice.

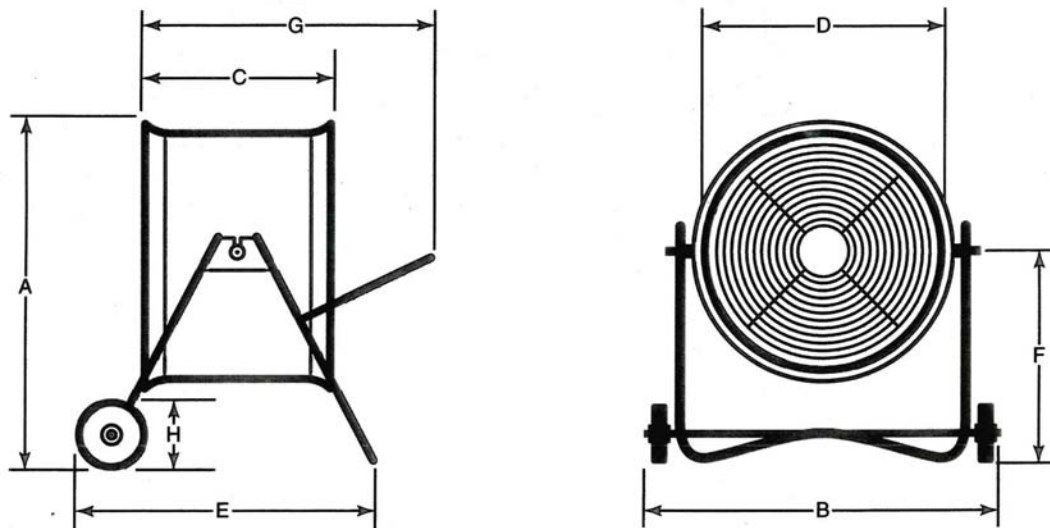

Fan Diameter mm	A mm	B mm	C mm	D mm	E mm	F mm
300	490	500	400	310	400	340
400	540	500	500	410	400	340

Mini Mancooler Fans

The Fanquip Mini Mancooler Fans have a blade diameter of 300 mm and 400 mm. The drum body is constructed in heavy gauge steel, strengthened at each end and protected with robust wire screens. The frame is tubular steel, light but robust and fitted with pivot bolts on each side allowing air beam deflection of 360°. The centrally mounted motor is coupled direct to the blade assembly and the isolating switch is externally fitted.

PERFORMANCE DATA

Performance Data	Model Number	Fan Diameter mm	Motor Speed r/s	Motor Power kW	Free Air Volume l/s	*Noise Level dB(A)
	1-30241/3	300	24	0.18	600	58
	1-30481/3	300	48	1.75	1400	64
	1-41241/3	400	24	0.18	1500	60
	1-41281/3	400	48	1.10	2150	74

*Note: Noise level is indicative only and should only be used to indicate relative values, as actual figures depend on the situation of the fan and the relevant field conditions.

All sizes etc shown are nominal. Subject to change without notice.

DIMENSIONS

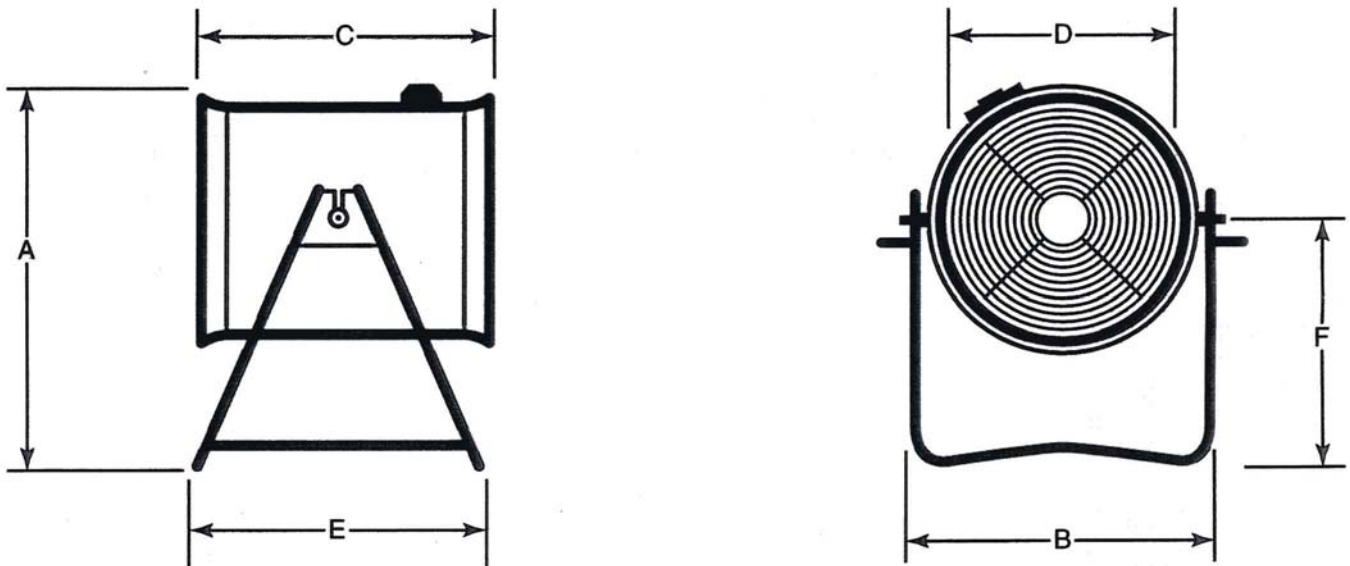

Fan Diameter mm	A mm	B mm	C mm	D mm	E mm	F mm	G mm	H mm
400	650	660	500	410	560	450	800	200 x 50
500	810	880	500	510	700	530	930	200 x 50
600	860	880	600	610	700	535	930	200 x 50
800	1050	1170	600	810	970	640	1050	200 x 50
1000	1370	1330	720	1015	1140	830	1260	300 x 50

Mancooler Fans

General Description

Fanquip offer a range of sturdy, high performance Mobile Mancooler fans. Fanquip Mobile Mancooler fans are ideal for heavy duty applications, extracting hot air, dust, smoke, etc, or providing a flow of fresh air to machinery and personnel. High volumes of air are obtainable making this unit suitable for a variety of industries.

Each fan is fully guarded to the Australian standard for complete safety. The precision designed units are strong, yet easy to manoeuvre. The Fanquip Mini Mancooler range is suitable for situations with limited space, where a steady airflow is required. The larger size Fanquip range offers a wide choice of air movement to cover all needs.

The motors are centrally mounted and coupled directly to the impeller assembly. A heavy duty on/off switch is fitted to the drum. All units are complete with overload protection. Each Fanquip unit is enamel finished in an attractive easy care colour.



Mobile Mancooler

For operation in hazardous locations, EX(d) and EX(e) motor protection is available. For corrosive environments, drum casings can be fabricated in stainless steel or aluminium. The complete fan units can be coated in epoxy resin for added protection.

Technical Advice

Industrial Fan Equipment Pty Ltd (Fanquip) has technical consultants available to give advice on the correct choice of Mancooler Fans for your needs.

Installation and Maintenance

The procedures as outlined in Fanquip installation, operation and maintenance instructions (separate leaflet), should be followed to ensure satisfactory performance and service life.

Warranty

Twelve months guarantee on mechanical and electrical componentry subject to satisfactory maintenance with assessment and rectification, if any, to take place after return by customer to Fanquip's workshop.



Mini Mancooler

 **FANQUIP**

INQUIP
BULK MATERIAL
& DUST HANDLING

22 Beneficial Way Wangara WA 6065 ☎ (08) 6314 1100 📠 (08) 9303 9447
🌐 inquip.com.au ✉ info@inquip.com.au

ABN 15 130 794 151

PRODUCT » DENSITY » FLOW