

**Makita**

128

マキタ

# Portable Cut-Off

355 mm (14") MODEL 2414B

## INSTRUCTION MANUAL

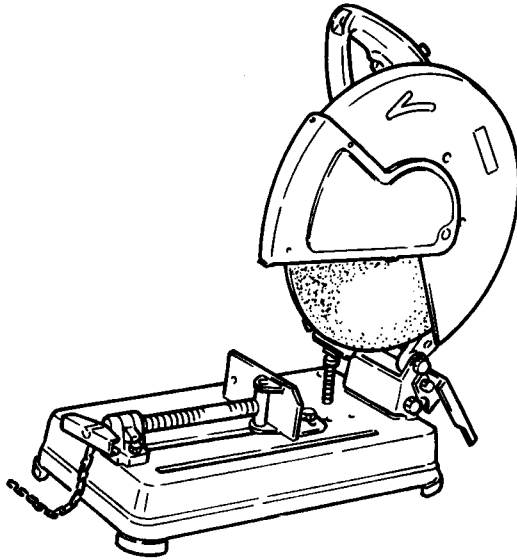

 **DOUBLE INSULATION**

### SPECIFICATIONS

Wheel diameter	Hole diameter	No load speed (RPM)	Dimensions (L x W x H)	Net weight
355 mm (14")	25.4 mm (1")	3,800	500 mm x 280 mm x 600 mm (19-11/16" x 11" x 23-5/8")	16.5 kg (36.3 lbs)

\* Manufacturer reserves the right to change specifications without notice.  
\* Note: Specifications may differ from country to country.

## ADDITIONAL SAFETY RULES

1. Wear hearing protection during extended periods of operation.
  2. Use only wheels having a maximum operating speed at least as high as "No Load RPM" marked on the tool's nameplate. Use only fiberglass-reinforced cut-off wheels.
  3. Check the wheel carefully for cracks or damage before operation. Replace cracked or damaged wheel immediately.
  4. Secure the wheel carefully.
  5. Use only flanges specified for this tool.
  6. Be careful not to damage the spindle, flanges (especially the installing surface) or bolt, or the wheel itself might break.
  7. Keep guards in place and in working order.
  8. Hold the handle firmly.
  9. Keep hands away from rotating parts.
  10. Make sure the wheel is not contacting the workpiece before the switch is turned on.
  11. Before using the tool on an actual workpiece, let it simply run for several minutes first. Watch for flutter or excessive vibration that might be caused by poor installation or a poorly balanced wheel.
  12. Watch out for flying sparks when operating. They can cause injury or ignite combustible materials.
  13. Remove material or debris from the area that might be ignited by sparks. Be sure that others are not in the path of the sparks. Keep a proper, charged fire extinguisher closely available.
  14. Use the cutting edge of the wheel only. Never use side surface.
  15. If the wheel stops during the operation, makes an odd noise or begins to vibrate, switch off the tool immediately.
  16. Always switch off and wait for the wheel to come to a complete stop before removing, securing workpiece, working vise, changing work position, angle or the wheel itself.
  17. Do not touch the workpiece immediately after operation; it is extremely hot and could burn your skin.
  18. Store wheels in a dry location only.
- SAVE THESE INSTRUCTIONS.**

### Removing or installing cut-off wheel

#### CAUTION:

Always be sure that the tool is switched off and unplugged before removing or installing the wheel.

To remove the wheel, loosen the screw and raise the center cover (center cap). Press the shaft lock so that the wheel cannot revolve and use the socket wrench to loosen the hex bolt by turning it counterclockwise. Then remove the hex bolt, outer flange and wheel. (Note: Do not remove the inner flange, ring and O-ring.)

To install the wheel, follow the removal procedures in reverse.

#### CAUTION:

- Be sure to tighten the hex bolt securely. Insufficient tightening of the hex bolt may result in severe injury. Use the socket wrench provided to help assure proper tightening.
- Always use only the proper inner and outer flanges which are provided with this tool.
- Always secure the center cover (center cap) firmly after replacing the wheel.

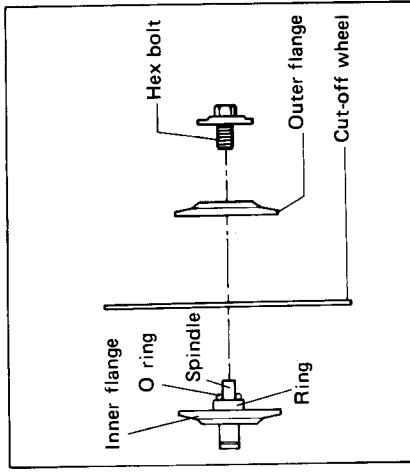
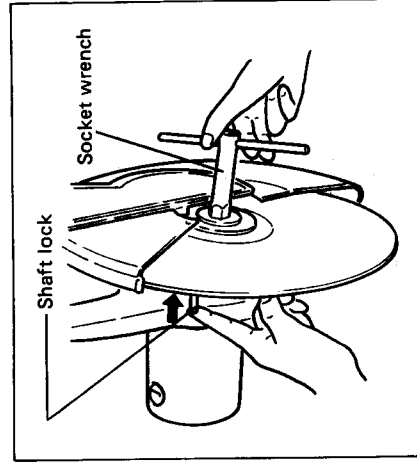

### Spark guard

The spark guard is factory-installed with its lower edge contacting the base. Before operation, loosen the screw and raise the spark guard so that its lower edge will be positioned approx. 45 mm (1-3/4") above the workbench or floor surface. Otherwise sparks may fly around operation area.

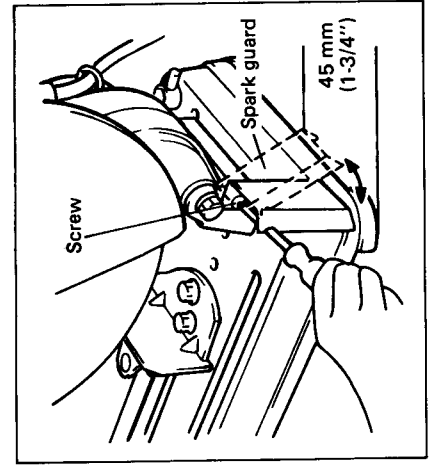

### Stopper plate

The stopper plate prevents the wheel from contacting the workbench or floor surface. When a new wheel is installed, set the stopper plate to the position (A). When the wheel wears down to below 330 mm (13") in diameter, set the stopper plate to the position (B) to allow an increased cutting capacity with the worn down wheel.

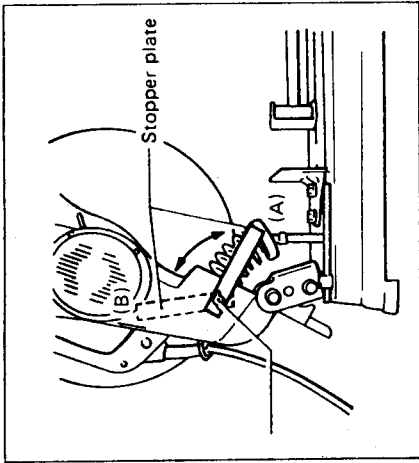

### Interval between vise and guide plate

The original spacing or interval between the vise and the guide plate is 0 – 170 mm (0 – 6-11/16"). If your work requires wider spacing or interval, proceed as follows to change the spacing or interval.

Remove the two hex bolts which secure the guide plate. Move the guide plate as shown in the figure and secure it using the hex bolts. The following interval settings are possible:

35 – 205 mm (1-3/8" – 8-1/16")

70 – 240 mm (2-3/4" – 9-7/16")

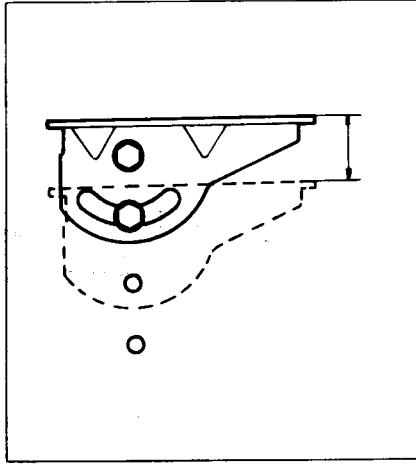
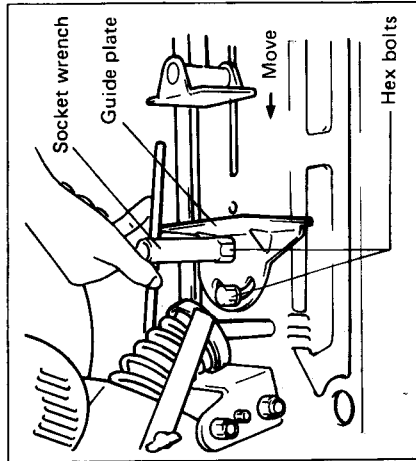

### CAUTION:

Remember that narrow workpieces may not be secured safely when using the two, wider interval settings.

### Setting for desired cutting angle

To change the cutting angle, loosen the two hex bolts which secure the guide plate. Move the guide plate to the desired angle (0° – 45°) and tighten the hex bolts securely.

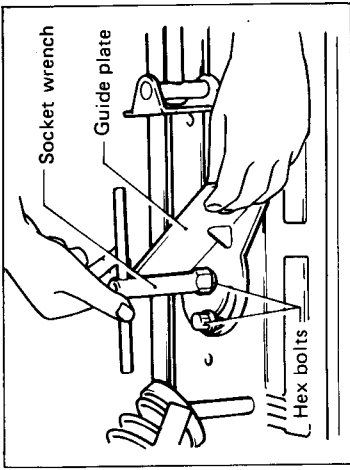

### CAUTION:

Never perform miter cuts when the guide plate is set at the 35 – 205 mm (1-3/8" – 8-1/16") or 70 – 240 mm (2-3/4" – 9-7/16") position.

### Securing workpieces

By turning the vise handle counterclockwise and then flipping the vise nut to the left, the vise is released from the shaft threads and can be moved rapidly in and out. To grip workpieces, push the vise handle until the vise plate contacts the workpiece. Flip the vise nut to the right and then turn the vise handle clockwise to securely retain the workpiece.

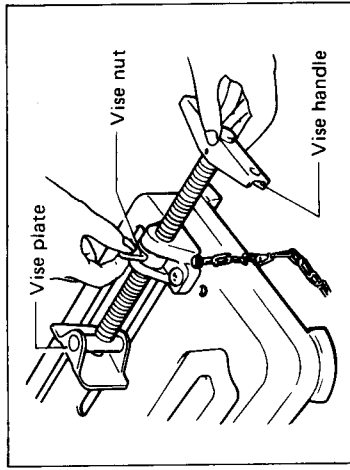

### CAUTION:

Always set the vise nut to the right fully when securing the workpiece. Failure to do so may result in insufficient securing of the workpiece. This could cause the workpiece to be ejected or cause a dangerous breakage of the wheel.

When the cut-off wheel has worn down considerably, use a spacer block of sturdy, non-flammable material behind the workpiece as shown in the figure. You can more efficiently utilize the worn wheel by using the mid point on the periphery of the wheel to cut the workpiece.

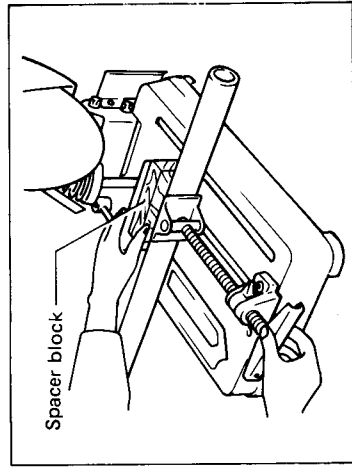

If you use a spacer block which is slightly narrower than the workpiece as shown in the figure, you can also utilize the wheel economically.

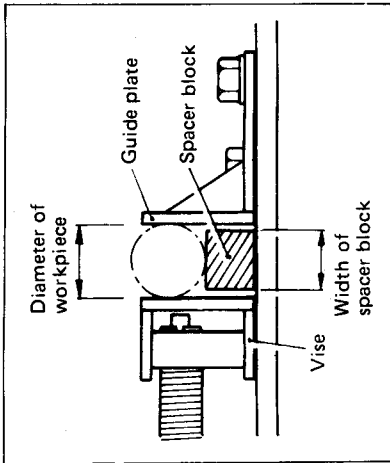

Long workpieces must be supported by blocks of non-flammable material on either side so that it will be level with the base top.

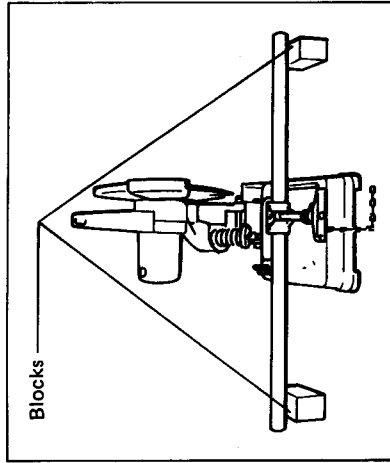

#### Switch action

To start the tool, simply pull the trigger. Release the trigger to stop. For continuous operation, pull the trigger and then push in the lock button. To stop the tool from the locked position, pull the trigger fully, then release it.

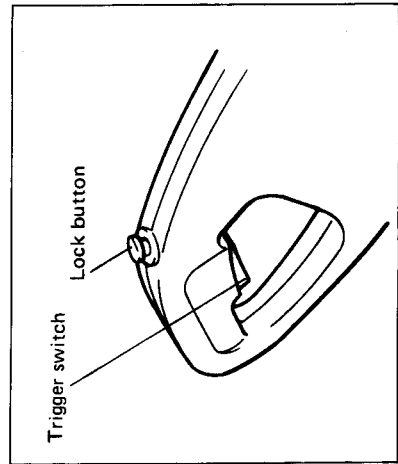

#### CAUTION:

Before plugging in the tool, always check to see that the trigger switch actuates properly and returns to the "OFF" position when released.

#### Operation

Hold the handle firmly. Switch on the tool and wait until the wheel attains full speed before lowering gently into the cut. When the wheel contacts the workpiece, gradually bear down on the handle to perform the cut. When the cut is completed, switch off the tool and **WAIT UNTIL THE WHEEL HAS COME TO A COMPLETE STOP** before returning the handle to the fully elevated position.

#### CAUTION:

Proper handle pressure during cutting and maximum cutting efficiency can be determined by the amount of sparks that is produced while cutting. Your pressure on the handle should be adjusted to produce the maximum amount of sparks. Do not force the cut by applying excessive pressure on the handle. Reduced cutting efficiency, premature wheel wear, as well as, possible damage to the tool, cut-off wheel or workpiece may result.

#### Cutting capacity

Max. cutting capacity varies depending upon the cutting angle and workpiece shape.

Workpiece shape	$\varnothing A$	A	A x B	A
90°	115 mm (4-1/2")	120 mm (4-23/32")	115 mm x 142 mm (4-1/2" x 5-5/8") 102 mm x 197 mm (4" x 7-3/4") 70 mm x 240 mm (2-3/4" x 9-7/16")	139 mm (5-1/2")
45°	115 mm (4-1/2")	106 mm (4-3/16")	115 mm x 102 mm (4-1/2" x 4")	100 mm (3-15/16")

### Tool head slide system

The tool head slides back toward you approx. 17 mm (21/32") when you pull the handle. This system is convenient for the following applications.

1. When cutting thick pipes or bars:  
Move the handle back and forth to slide the tool head. This will help increase cutting efficiency and prevent wheel loading.
2. When cutting channels or angles:  
If a portion of the workpiece near you is left uncut, pull the handle. The tool head slides back and the wheel cuts the remaining uncut portion. If the uncut portion cannot be cut even by using this method, use a spacer block as explained above.

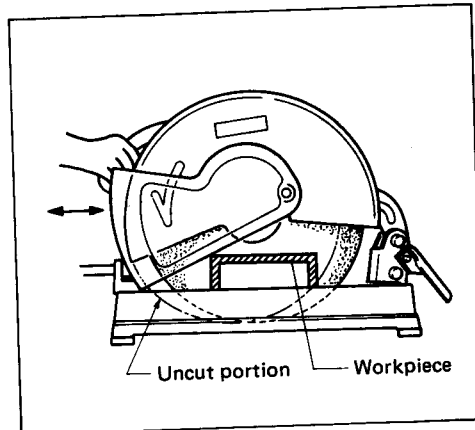
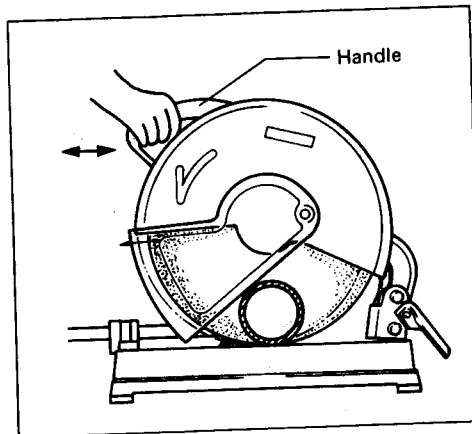

### Carrying the tool

Fold down the tool head to the position where you can attach the chain to the hook on the handle.

