

Hitachi Power Tools

SERVICE MANUAL

LIST No. E482
Oct. 2004

PRODUCT NAME

Hitachi Demolition Hammer

Model H 65SB2

CONTENTS	Page
PRECAUTIONS IN DISASSEMBLY AND REASSEMBLY	1
1. Disassembly	1
2. Reassembly	3
3. Application of Adhesive	5
4. Tightening Torque	5
5. Wiring Diagram	6
6. Insulation Tests	6
7. No-load Current Value	6
STANDARD REPAIR TIME (UNIT) SCHEDULES	7

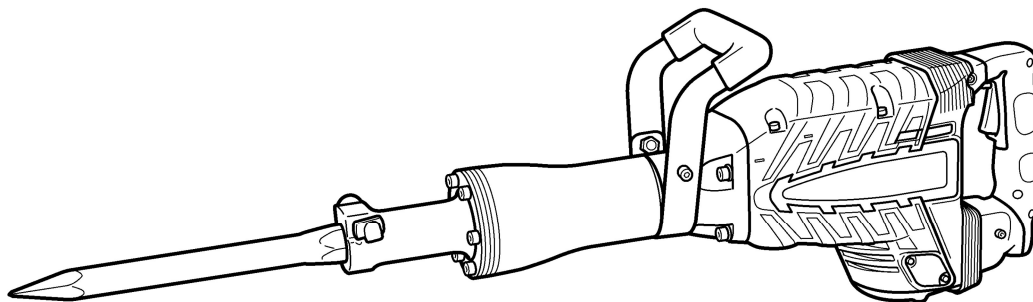

1. PRECAUTIONS IN DISASSEMBLY AND REASSEMBLY

The circled numbers in the descriptions below correspond to the item numbers in the Parts List and exploded assembly diagram.

1-1. Disassembly

NOTE: If it is difficult to loosen and remove the fixing bolts, use an appropriate heating device to heat them to approximately 80° (176°F).

(1) Disassembly of the Armature Ass'y [75]

- A. Loosen the four Seal Lock Hex. Socket Hd. Bolts M4 x 8 [54], remove the Cap Covers [55], Cap Rubbers [56] and Brush Caps [57], and take out the Carbon Brushes (Auto Stop Type) (1 Pair) [58]. At this time, be very careful not to lose the disassembled parts.
- B. Loosen the four Nylock Hex. Socket Hd. Bolts M8 x 35 [26], and remove the Cylinder Case [22]. Next, after loosening the Seal Lock Hex. Socket Hd. Bolt M8 x 16 [34], the Connecting Rod Ass'y [31] and the Crank Washer [33] can be disassembled. Leave the Striker [24] and the Piston [30] as they are.
- C. Remove the four Seal Lock Hex. Socket Hd. Bolts M5 x 16 [63] and three Tapping Screws (W/Flange) D4 x 25 (Black) [96]. Remove Handle (A) [85], Handle (B) [87], four Nylock Bolts (W/Flange) M5 x 12 [105] and Back Cover [82]. Remove the six Seal Lock Hex. Socket Hd. Bolts M6 x 45 [60], Gear Cover [38] and Counter Gear [65]. Insert a flat-blade screwdriver or a similar tool into the air vent of the Inner Cover [42] and raise the Inner Cover [42]. Then the Inner Cover [42], Armature Ass'y [75] and Crank Shaft [47] can be removed as a single unit. At this time, be very careful not to damage the Fan [74].
- D. As illustrated in Fig. 1, support the Inner Cover [42] with an appropriate tubular jig, and push down on the end surface of the armature shaft with a hand press to separate the Armature Ass'y [75] from the Inner Cover [42].

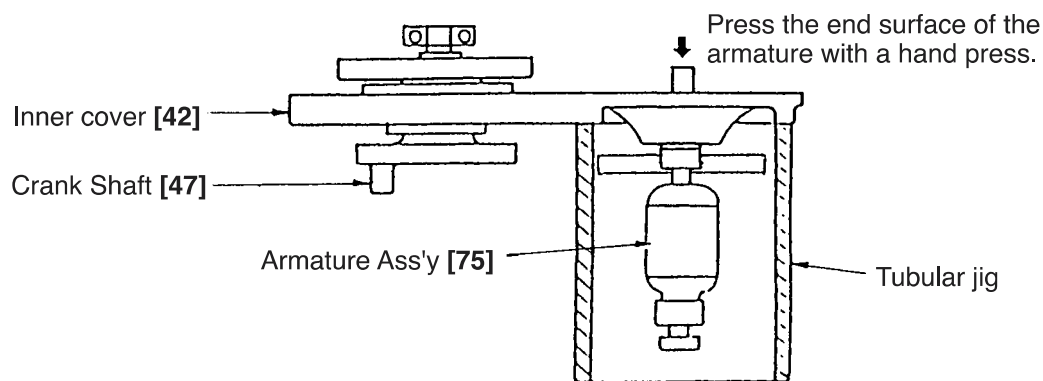

Fig. 1

(2) Disassembly of the Crank Shaft [47] section:

First, remove the four Seal Lock Hex. Socket Hd. Bolts M5 x 16 [46] which fix the Bearing Cover [45]. Then, as illustrated in Fig. 2, support the lower surface of the Inner Cover [42] with an appropriate tubular jig, align an appropriate steel rod with the end surface of the Crank Shaft [47], and press down on the steel rod with a hand press. The Ball Bearing 6205DDCMPS2L [44], Distance Ring (B) [41], Final Gear [40], two Woodruff Keys 4 x 16 [71], and Crank Shaft [47] can then be disassembled from the Inner Cover [42].

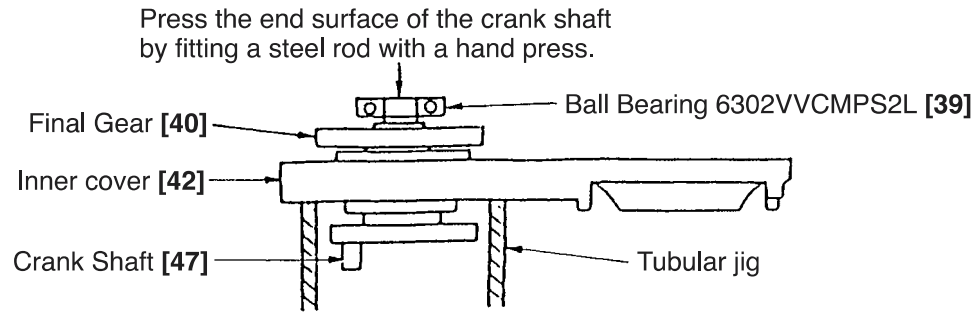

Fig. 2

(3) Disassembly of remaining parts from the Inner Cover [42]:

Loosen the three Seal Lock Hex. Socket Hd. Bolts M5 x 16 [46], and take out Bearing Cover (A) [67] and the Ball Bearing 6203DDCMP52L [68].

(4) Disassembly of the Mouth [17] and related parts:

Remove six Nylock Hex. Socket Hd. Bolts M8 x 40 [1]. Remove the Collar [3], Damper Plate [2], two Front Dampers [4] and Front Cover [8] from the Cylinder Case [22]. Then the Second Hammer [9], Shank Sleeve [16], Damper (A) [14], Mouth [17], Mouth Cover [18], Mouth Washer [19] and Urethane Ring [20] can be removed as a single unit.

(5) Removal of the O-ring (I.D 26.5) [15]:

As the O-ring (I.D 26.5) [15] is installed in the inner portion of the Shank Sleeve [16], it may be difficult to remove. As illustrated in Fig. 3, pry the O-ring upward gently with a small minus screwdriver, being very careful not to damage the surface of the O-ring.

(6) Removal of the Striker [24] and related parts:

Remove the four Nylock Hex. Socket Hd. Bolts M8 x 35 [26], and separate the Cylinder Case [22] from the Housing Ass'y [49]. From the Cylinder Case [22], take out the Striker [24], Piston [30], and Connecting Rod Ass'y [31] in a single body. Holding the Striker [24] firmly in one hand, grasp the Connecting Rod Ass'y [31] in the other hand and pull it forcefully to separate it from the striker. Finally, extract the Piston Pin [29] from the Piston [30], and separate the Piston from the Connecting Rod Ass'y [31].

(7) Disassembly of the Stop Lever [10]:

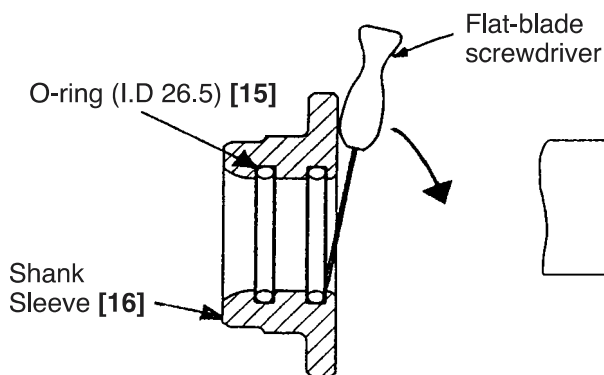

Fig. 3

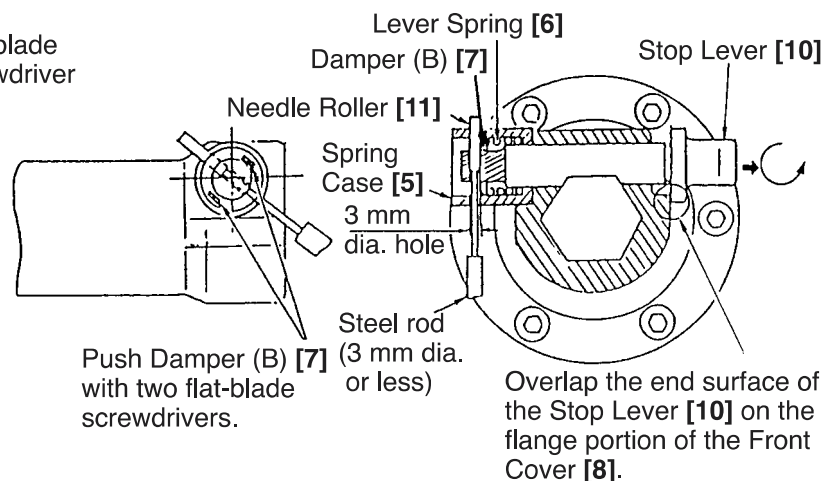

Fig. 4

Disassembly procedures are illustrated in Fig. 4. Pull the Stop Lever [10] outward in the direction indicated by the arrow, and turn it slightly so that its end surface comes to rest on the flange portion of the Front Cover [8]. Next, turn the Spring Case [5] so that the holes of the Spring Case [5] are aligned with the Needle Roller [11]. Then, push in Damper (B) [7] with flat-blade screwdrivers to compress the Lever Spring [6]. Finally, while keeping the lever spring compressed, fit a 3 mm dia. or less steel rod into the hole of the Spring Case [5], and push out the Needle Roller [11]. The Stop Lever [10], Damper (B) [7], and the Lever Spring [6] can then be taken out.

1-2. Reassembly

Reassembly can be accomplished by following the disassembly procedures in reverse. However, special attention should be given to the following items.

(1) Reassembly of the Crank Shaft [47] section:

Press-fit the Ball Bearing 6205DDCMPS2L [44] into the Inner Cover [42], and fasten the Bearing Cover [45] onto the Inner Cover [42] with the four Seal Lock Hex. Socket Hd. Bolts M5 x 16 [46]. Support the inner race of the Ball Bearing 6205DDCMPS2L [44] with an appropriate jig, and press-fit the Crank Shaft [47] into the ball bearing. Next, insert Distance Ring (B) [41] and the two Woodruff Keys 4 x 16 [71] into the Crank Shaft [47], and press-fit the Final Gear [40] and the Ball Bearing 6302VVCMP2L [39] with a hand press.

(2) Reassembly of the Armature Ass'y [75]:

Press fit the Ball Bearing 6203DDCMPS2L [68] into the Inner Cover [42], and fasten Bearing Cover (A) [67] onto the inner cover with the three Seal Lock Hex. Socket Hd. Bolts M5 x 16 [46].

(3) Reassembly of the Striker [24]: (Two possible methods)

A. After the Connecting Rod Ass'y [31] has been assembled into the Housing Ass'y [49], mount the Piston [30] and press it into the Striker [24].

B. Mount the Piston [30] onto the Connecting Rod Ass'y [31], and push down on the Connecting Rod Ass'y [31] to press the Piston [30] into the Striker [24].

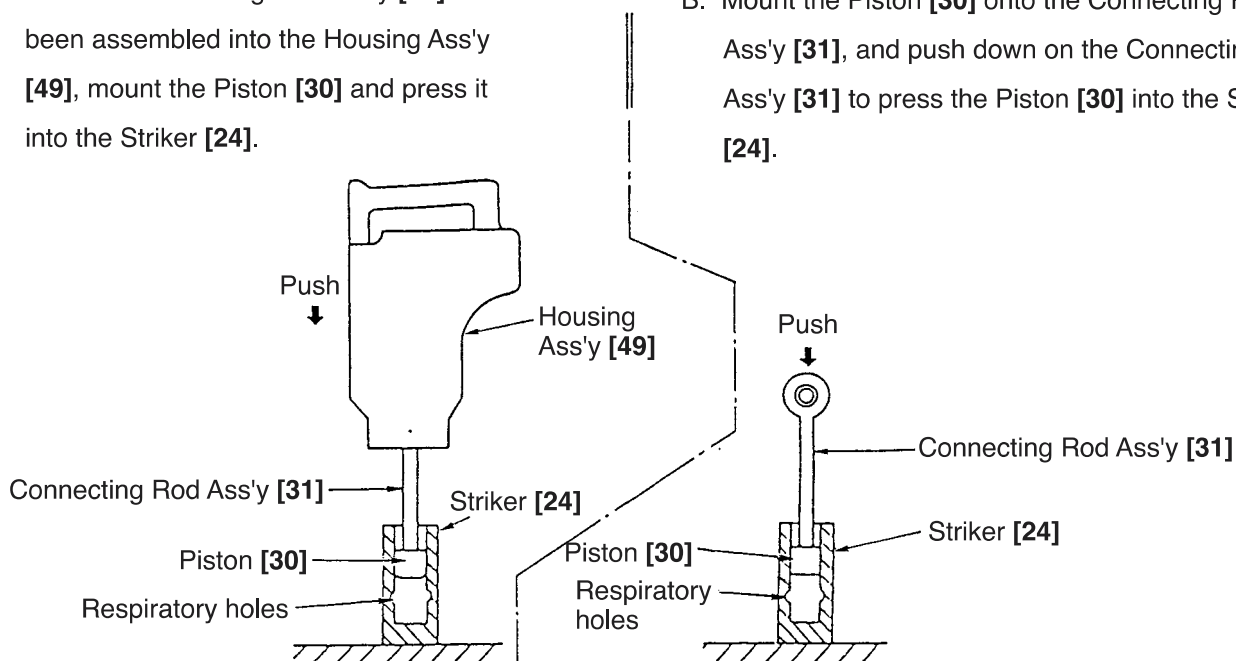

Fig. 5

Either of the two methods described above requires a pressing force of more than 30 kg. When a "hissing" sound is heard, the piston is properly inserted in the striker. (The "hissing" is the sound of the compressed air escaping from the striker when the piston reaches the respiratory chambers within the striker.)

(4) Mounting Oil Seal (A) [28]:

When mounting Oil Seal (A) [28] on the Piston [30], ensure that the lip portion of the oil seal is directed toward the rear surface of the piston, as illustrated in Fig. 6.

Prior to reassembly, thoroughly coat grease (Grease for Impact Drill, Part No. 980927, is recommended) on Oil Seal (A) [28] and O-ring (A) [25], and carefully ensure they are not damaged.

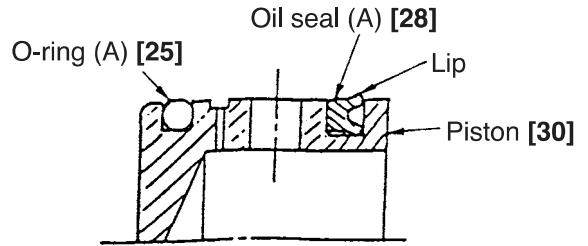

Fig. 6

(5) Safety precautions in wiring work: (See Fig. 7.)

Switch (B) (1P Screw Type) W/Lock [103] is flexibly supported by the Support [104] to protect it from damage due to vibration which could lead to possible electrical shock. Ensure without fail that the Support [104] is properly mounted. Also, ensure that the leadwires are properly covered by Vinyl Tube (A) (I.D.7 x T0.5 x 50) [100], and that the leadwires of the Stator Ass'y [78] and the grounding leadwire are properly supported by the internal Vinyl Tube [79].

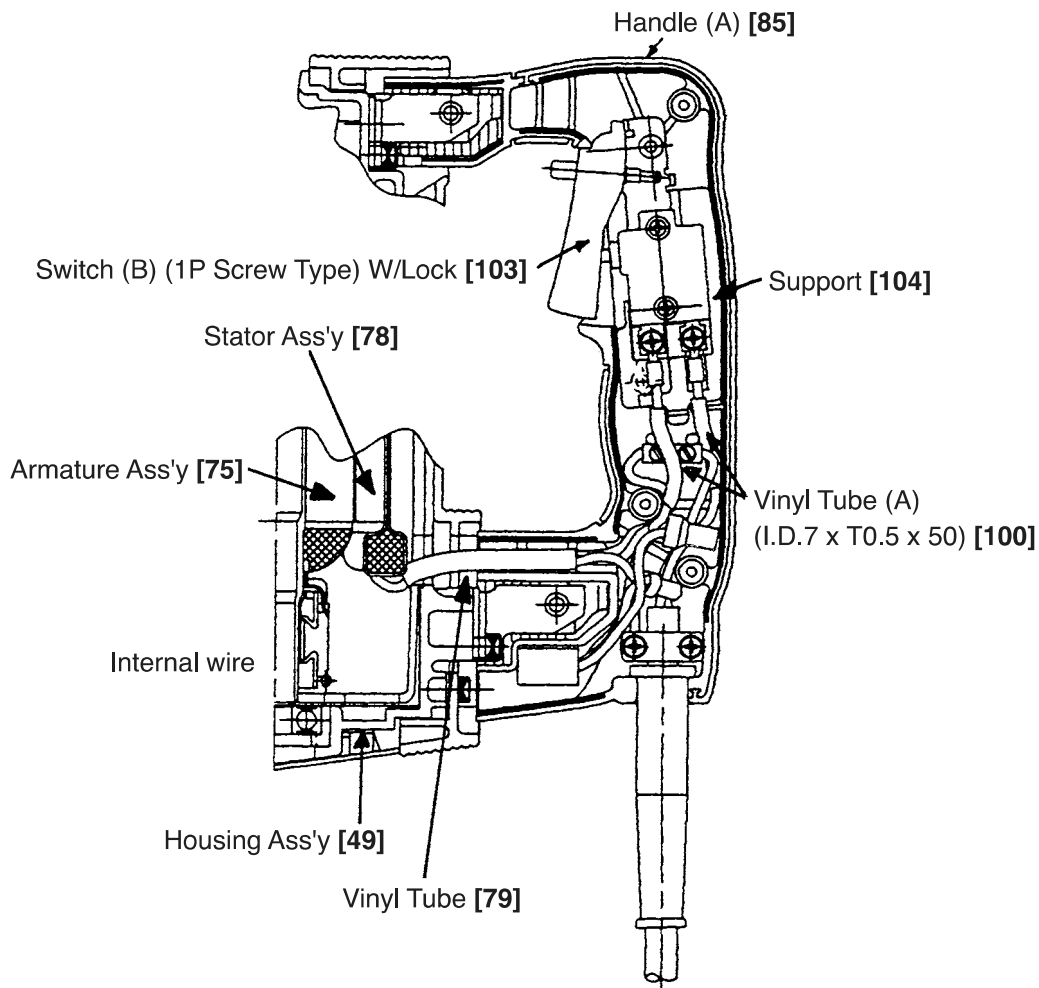

Fig. 7

(6) Reassembly of the Stop Lever [10]:

Prior to reassembly, thoroughly coat the grease (Doubrex 251, Part No. 980757, is recommended) on the sliding portion of the Stop Lever [10]. As illustrated in Fig. 8, place the end surface of the Stop Lever [10] on the flange portion of the Front Cover [8] and compress the Lever Spring [6] by pressing Damper (B) [7] with two slender flat-blade screwdrivers. Then, align the holes of the Stop Lever [10] and the Spring Case [5], and insert the Needle Roller [11].

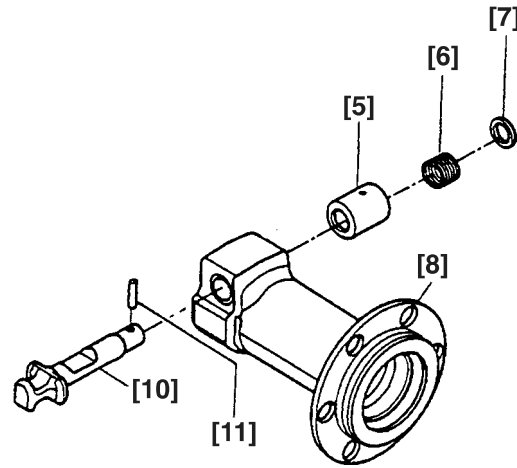

Fig. 8

1-3. Application of Adhesive

(1) Prior to reassembly, all hexagon socket hd. bolts M5 and M6, and machine screws must be coated with Screw Locking Agent TB1401.

(2) The following parts must be replaced with Hitachi Genuine Parts if they are loosened.

- Front cover fixing bolts: M8 x 40 [1]
- Cylinder case fixing bolts: M8 x 35 [26]
- Fixing bolt on the Connecting Rod Ass'y [31] : M8 x 16 [34]

⚠ CAUTION: If fastening bolts come loose from vibration, it could cause serious damage to the machine. Ensure without fail that TB 1401 Screw Locking Agent is applied as directed above prior to reassembly.

Before applying the TB 1401, carefully clean any grease or other foreign matter from the male and female threads with gasoline, thinner or similar cleaning solvents.

1-4. Tightening Torque

Hexagon socket flanged bolts M5	40 ± 5 kg-cm (34.8 ± 4.3 lb-in)
Hexagon socket hd. bolts M4	45 ± 5 kg-cm (39.1 ± 4.3 lb-in)
Hexagon socket hd. bolts M5	$80 \begin{smallmatrix} +20 \\ 0 \end{smallmatrix}$ kg-cm ($69.5 \begin{smallmatrix} +12.4 \\ 0 \end{smallmatrix}$ lb-in)
Hexagon socket hd. bolts M6	$100 \begin{smallmatrix} +20 \\ 0 \end{smallmatrix}$ kg-cm ($86.9 \begin{smallmatrix} +17.4 \\ 0 \end{smallmatrix}$ lb-in)
Hexagon socket hd. bolts M8	$300 \begin{smallmatrix} +20 \\ 0 \end{smallmatrix}$ kg-cm ($260 \begin{smallmatrix} +17.4 \\ 0 \end{smallmatrix}$ lb-in)
Tapping screw D4	$20 \begin{smallmatrix} \pm 5 \\ 0 \end{smallmatrix}$ kg-cm ($17.4 \begin{smallmatrix} +4.3 \\ 0 \end{smallmatrix}$ lb-in)

NOTE: If above bolts are tightened more than the designated values, it may cause breakage.

Without fail, tighten the bolts and screws according to the above specified values.

1-5. Wiring Diagram

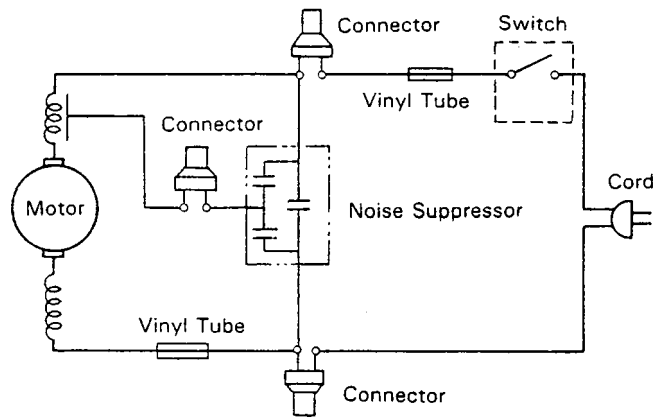

Fig. 9

1-6. Insulation Tests

After disassembly for repair servicing, the insulation resistance should be measured and the dielectric strength test (withstand voltage test) performed.

Insulation resistance: 7 M Ω or greater

Dielectric strength: Normal after applying 4000 V for one minute.

1-7. No-load Current Value

After no-load operation for 30 minutes, the no-load current value should be as follows:

Voltage	110 V	115 V	120 V	127 V	220 V	230 V	240 V
Current (A) Max.	5.9 A	5.7 A	5.4 A	5.2 A	3.0 A	2.8 A	2.7 A

2. STANDARD REPAIR TIME (UNIT) SCHEDULES

MODEL	Variable		10	20	30	40	50	60	70	80	
	Fixed										
H 65SB2		Work Flow									
				Switch (B) Cord Cord Armor							
		Tail Cover									Housing Ass'y Stator Ass'y
		General Assembly		Handle (A) Handle (B) Handle Rubber x 2 Back Cover	Gear Cover Ball Bearing (6302VV) Final Gear Ball Bearing (6201VV) Counter Gear Ball Bearing (6001VV)		Armature Ass'y Ball Bearing (6201DD)				
		Stop Lever			Front Cover Second Hammer O-ring (C) O-ring (B) Damper (A) O-ring x 2 Shank Sleeve Mouth Mouth Cover Urethane Ring		Inner Cover Ball Bearing (6205DD) Crank Shaft Ball Bearing (6203DD)				
						Striker O-ring (1AS-60) O-ring (A) Oil Seal (A) Piston Connecting Rod Ass'y Needle Bearing		Cylinder Case			

ELECTRIC TOOL PARTS LIST

DEMOLITION HAMMER

2004 · 10 · 10

Model H 65SB2

(E1)

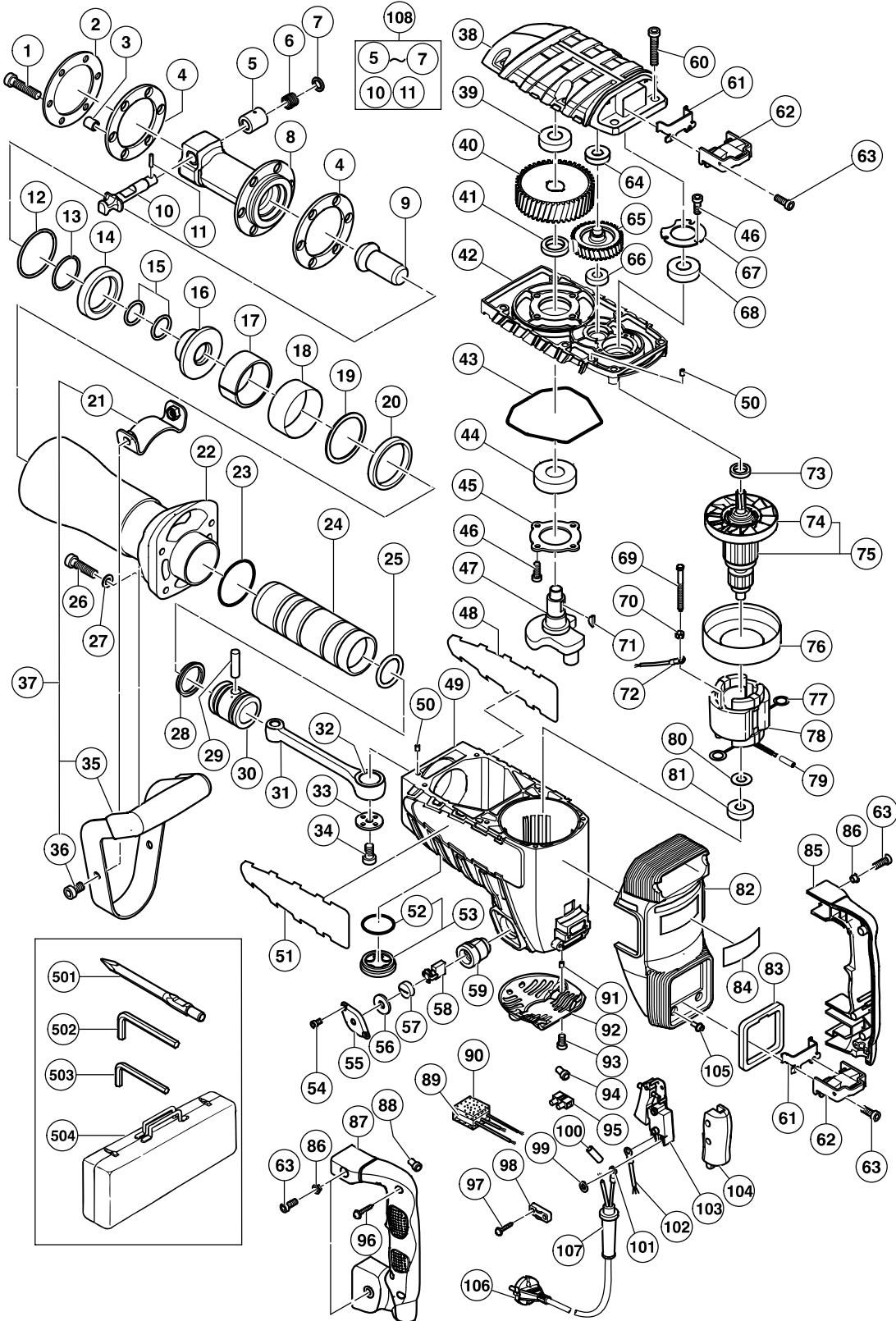

PARTS

H 65SB2

ITEM NO.	CODE NO.	DESCRIPTION	NO. USED	REMARKS
1	323-734	NYLOCK HEX. SOCKET HD. BOLT M8X40	6	
2	323-736	DAMPER PLATE	1	
3	323-737	COLLAR	6	
4	323-735	FRONT DAMPER	2	
5	998-424	SPRING CASE	1	
6	956-975	LEVER SPRING	1	
7	998-425	DAMPER (B)	1	
8	323-733	FRONT COVER	1	
9	323-732	SECOND HAMMER	1	
10	323-748	STOP LEVER	1	
11	998-426	NEEDLE ROLLER	1	
12	998-428	O-RING (C)	1	
13	998-427	O-RING (B)	1	
14	998-433	DAMPER (A)	1	
15	323-731	O-RING (I.D 26.5)	2	
16	323-730	SHANK SLEEVE	1	
17	956-963	MOUTH	1	
18	956-962	MOUTH COVER	1	
19	323-729	MOUTH WASHER	1	
20	956-960	URETHANE RING	1	
21	320-374	HANDLE STAY (W/NUT)	1	
22	323-728	CYLINDER CASE	1	
23	956-996	O-RING (1AS-60)	1	
24	323-724	STRIKER	1	
25	998-414	O-RING (A)	1	
26	306-163	NYLOCK HEX. SOCKET HD. BOLT M8X35	4	
27	949-433	BOLT WASHER M8 (10 PCS.)	4	
28	998-415	OIL SEAL (A)	1	
29	944-928	PISTON PIN	1	
30	998-413	PISTON	1	
31	998-434	CONNECTING ROD ASS'Y	1	INCLUD. 32
32	944-921	NEEDLE BEARING (NTN 8E-NK 18/20 RDO)	1	
33	956-955	CRANK WASHER	1	
34	996-364	SEAL LOCK HEX. SOCKET HD. BOLT M8X16	1	
35	306-166	GRIP	1	
36	320-375	NYLOCK HEX. SOCKET HD. BOLT M8X16	2	
37	306-165	SIDE HANDLE ASS'Y	1	INCLUD. 21, 35, 36
38	323-723	GEAR COVER	1	
39	630-2VV	BALL BEARING 6302VVCMP2L	1	
40	944-916	FINAL GEAR	1	
41	944-915	DISTANCE RING (B)	1	
42	323-722	INNER COVER	1	
43	323-725	SEAL RING	1	
44	620-5DD	BALL BEARING 6205DDCMP2L	1	
45	956-949	BEARING COVER	1	
46	990-079	SEAL LOCK HEX. SOCKET HD. BOLT M5X16	7	
47	998-430	CRANK SHAFT	1	
48		HITACHI LABEL	1	
49	323-721	HOUSING ASS'Y	1	INCLUD. 59, 91
50	944-918	PIN D5X15.8	2	
51		HITACHI LABEL	1	

PARTS

H 65SB2

ITEM NO.	CODE NO.	DESCRIPTION	NO. USED	REMARKS	
52	980-717	O-RING (S-38)	1		
53	990-945	OIL CAP ASS'Y	1	INCLUD. 52	
54	877-838	SEAL LOCK HEX. SOCKET HD. BOLT M4X8	4		
55	323-727	CAP COVER	2		
56	944-960	CAP RUBBER	2		
57	940-540	BRUSH CAP	2		
58	999-086	CARBON BRUSH (AUTO STOP TYPE) (1 PAIR)	2		
59	956-984	BRUSH HOLDER	2		
60	986-940	SEAL LOCK HEX. SOCKET HD. BOLT M6X45	6		
61	980-750	GUIDE PLATE	2		
62	980-727	HANDLE RUBBER	2		
63	990-079	SEAL LOCK HEX. SOCKET HD. BOLT M5X16	8		
64	620-1VV	BALL BEARING 6201VVCMP2L	1		
65	956-948	COUNTER GEAR	1		
66	600-1VV	BALL BEARING 6001VVCMP2L	1		
67	944-911	BEARING COVER (A)	1		
68	620-3DD	BALL BEARING 6203DDCMPS2L	1		
69	960-251	HEX. HD. TAPPING SCREW D5X65	2		
70	956-764	SPECIAL WASHER	2		
71	956-850	WOODRUFF KEY 4X16	2		
*	72	994-190	INTERNAL WIRE	1	FOR NZL, AUS, GBR, SAF, EUROPE, FIN, NOR, SWE, DEN, AUT, SUI
	73	944-907	DISTANCE RING (A)	1	
	74	996-370	FAN	1	
*	75	360-286C	ARMATURE ASS'Y 110V-115V	1	INCLUD. 74
*	75	360-286E	ARMATURE ASS'Y 220V-230V	1	INCLUD. 74
*	75	360-286F	ARMATURE ASS'Y 240V	1	INCLUD. 74
	76	306-098	FAN GUIDE	1	
	77	945-932	BRUSH TERMINAL	2	
*	78	340-259C	STATOR ASS'Y 110V-115V	1	INCLUD. 77
*	78	340-259E	STATOR ASS'Y 220V-230V	1	INCLUD. 77
*	78	340-259F	STATOR ASS'Y 240V	1	INCLUD. 77
*	78	340-259H	STATOR ASS'Y 240V	1	INCLUD. 77 FOR AUS
	79	322-530	VINYL TUBE	1	
	80	944-954	BEARING WASHER	1	
	81	620-1DD	BALL BEARING 6201DDCMPS2L	1	
	82	323-740	BACK COVER	1	
	83	323-741	HANDLE PACKING	1	
	84		NAME PLATE	1	
	85	323-743	HANDLE (A)	1	
	86	991-711	DISTANCE PIECE (B)	4	
	87	323-744	HANDLE (B)	1	
*	88	959-141	CONNECTOR 50092 (10 PCS.)	2	
*	88	959-141	CONNECTOR 50092 (10 PCS.)	1	FOR AUS, GBR, SAF, EUROPE, FIN, NOR, SWE, DEN, AUT, SUI
*	89	994-273	NOISE SUPPRESSOR	1	FOR NZL, AUS, SAF
*	89	317-491	NOISE SUPPRESSOR	1	FOR GBR, EUROPE, FIN, NOR, SWE, DEN, AUT, SUI
*	90	930-153	SUPPORT (B)	1	FOR NOISE SUPPRESSOR
	91	938-477	HEX. SOCKET SET SCREW M5X8	2	
	92	938-733	TAIL COVER	1	

