

# HONDA

Grass/Weed Trimmer

UMK422 • UMK431

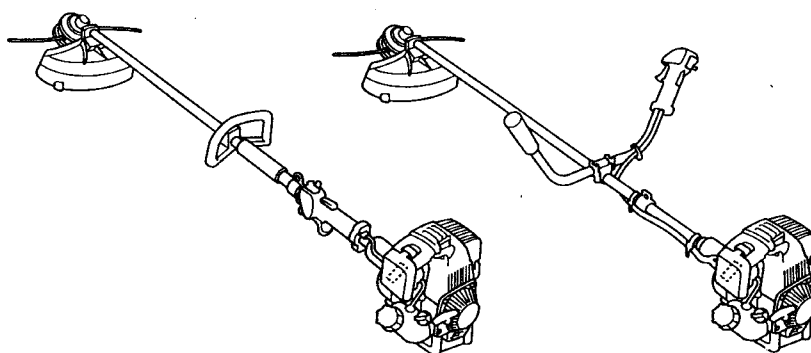

OWNER'S MANUAL  
MANUEL DE L'UTILISATEUR

© HONDA MOTOR CO., LTD. 2000

4. Pull the starter grip lightly until you feel resistance while holding the main pipe, then pull briskly. Return the starter grip gently.

**CAUTION:**

- Do not allow the starter grip to snap back against the engine. Return it gently to prevent damage to the starter.
- Damage may result if the starter grip is pulled while the engine is running.

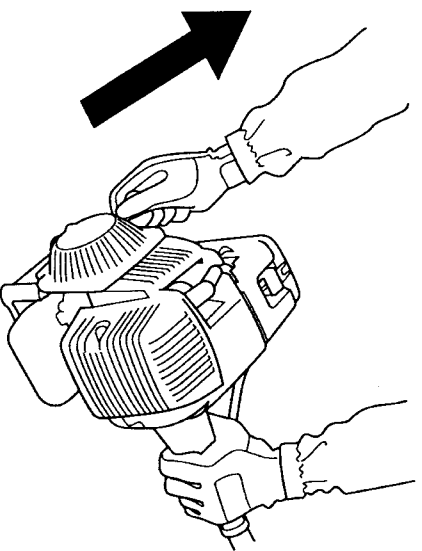

5. If the choke lever has been moved to the CLOSED position to start the engine, gradually move it to the OPEN position as the engine warms up.

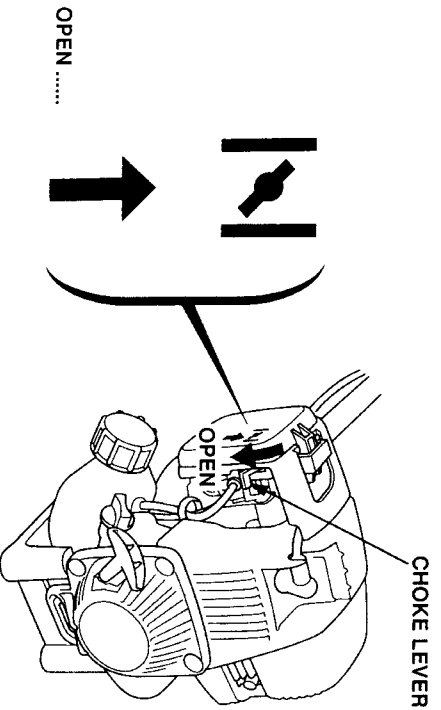

**Idle-up function**

The idle-up function is a function that helps an engine to start by opening the throttle valve in the carburetor moderately when the engine won't start.

1. Hold down the throttle trigger interlock.
2. Pull the throttle trigger.
3. Push the idle-up knob, then release the throttle trigger and throttle trigger interlock in that order.
4. Start the engine.

**NOTE:** This function must not be used while trimming work.

If the engine won't start after performing the idle-up function, consult the Honda servicing dealer.

**Loop handle type:**

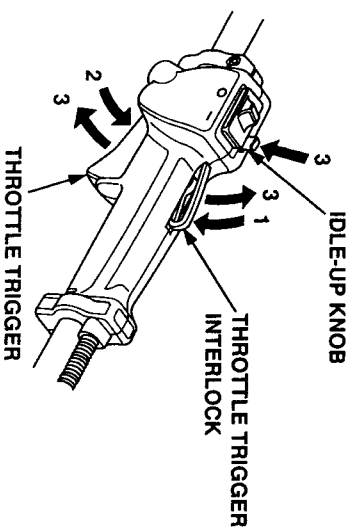

**U-shaped handle type:**

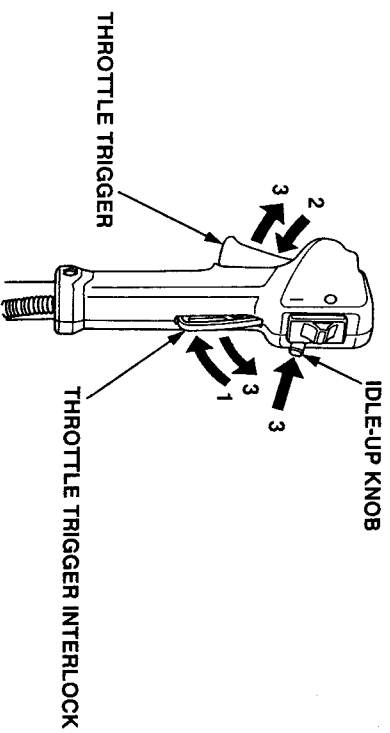

## 6. STARTING THE ENGINE

### ⚠ WARNING

- Exhaust gas contains poisonous carbon monoxide. Never run the engine in an enclosed area. Be sure to provide adequate ventilation.
- Start the engine in a place away from the people, pets, and surrounding buildings. Be sure there are no obstacles in the working area.

**CAUTION:** Do not start the engine with the grass/weed trimmer hanged from the carrying harness or raised in the air off the ground. The trimmer can make unexpected movement causing injury in your legs, etc.

**NOTE:** Place the grass/weed trimmer in an area free from the obstacles, and be sure the cutting attachment is not in contact with the ground and other materials.

1. Turn the engine switch to the ON position.

Loop handle type:

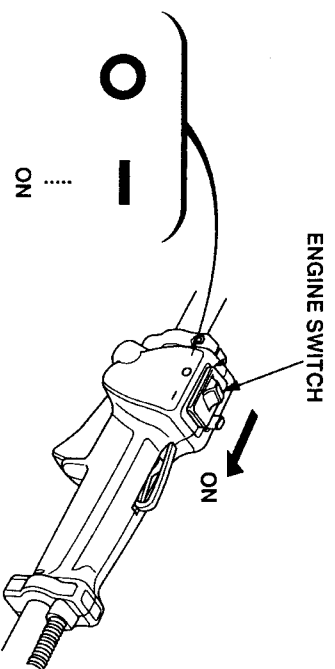

U-shaped handle type:

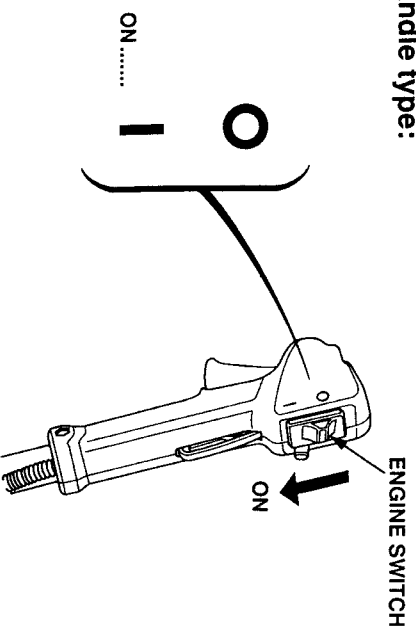

2. To start a cold engine, move the choke lever to the CLOSED position.

To restart warm engine, leave the choke lever in the OPEN position.

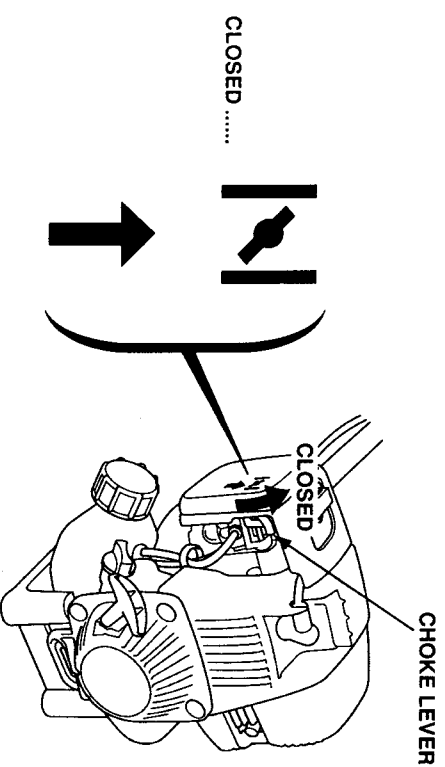

3. Press the priming pump several times until a flow in the fuel return tube (transparent tube) is visually noticed.

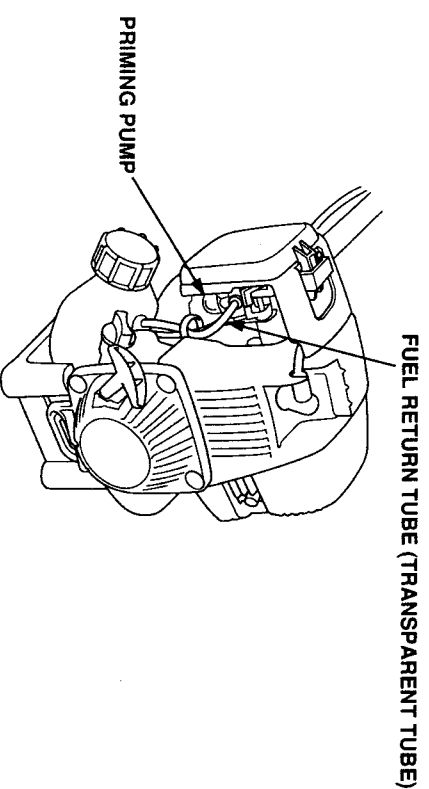

**A WARNING**

**To ensure safe operation**

**Fire and Burn Hazard**

Gasoline is extremely flammable, and gasoline vapor can explode.

Use extreme care when handling gasoline. Keep gasoline out of reach of children.

- Store fuel in containers specifically designed for this purpose.
  - Refuel outdoors only, and do not smoke while refueling or handling fuel.
  - Add fuel before starting the engine. Never remove the cap of the fuel tank or add petrol while the engine is running or when the engine is hot.
  - If gasoline is spilled, do not attempt to start the engine but move the grass/weed trimmer away from the area of spillage and avoid creating any source of ignition until gasoline vapours have dissipated.
  - Tighten all fuel tanks and container caps securely.
  - When you start the engine after refueling, be sure to start the engine at least 3 m (3.2 ft.) away from the refueling spot.
  - Never store the grass/weed trimmer with gasoline in the tank inside a building where fumes may reach an open flame, spark or high temperature source.
  - Allow the engine to cool before storing in any enclosure.
  - To reduce the fire hazard, keep the grass/weed trimmer, especially the engine, muffler, the gasoline storage area as well, free of grass, leaves, or excessive grease.
- Do not leave containers of vegetable matters in or near a building.
- If the fuel tank has to be drained, this should be done outdoors, with a cold engine.

**A WARNING**

**To ensure safe operation**

**Carbon Monoxide Poisoning Hazard**

Exhaust contains poisonous carbon monoxide, a colorless and odorless gas.

Breathing exhaust can cause loss of consciousness and may lead to death.

- If you run the engine in an area that is confined or even partially enclosed, the air you breathe could contain a dangerous amount of exhaust gas. To keep exhaust gas from building up, provide adequate ventilation.
- Replace faulty muffler.
- Do not operate the engine in a confined space where dangerous carbon monoxide fumes can collect.

**WARNING**

**To ensure safe operation**

**Operator Responsibility**

- Injury caused by vibration and cold:  
You may feel the pricking or burning pain in your fingers, and the fingers may lose color and feeling depending on your constitution. It is believed that these symptoms are brought by vibration and/or exposure to cold. The specific trigger point of these symptoms are not identified yet, but observe the following instructions.
  - \* Limit the amount of time you spend operating the grass/weed trimmer in a day.  
A day's work should consist of the work with the grass/weed trimmer and the other work without the hand-held equipment so you can limit the amount of time when your hands are exposed to the machine vibration.
  - \* Keep your body warm, especially your hands, wrists and arms.
  - \* Take your breaks at shorter intervals and arm exercises well to maintain good blood circulation. Do not smoke while working.
  - \* When you feel discomfort, redness and swelling of the fingers followed by whitening and loss of feeling, consult your doctor promptly.
- Injury caused by repeated operation:  
Performing the repeated operation for a prolonged time may cause injury. Observe the following instructions to reduce the causes of the injury.
  - \* Avoid the repeated operation by using your wrist(s) in bent, stretched or twisted position.
  - \* Take your breaks regularly to minimize the effect of the repeated operation. Take your time when performing the repeated operation. Do not rush to operate the grass/weed trimmer.
  - \* When your fingers, hands, wrists and/or arms are throbbing or numbed, consult your doctor.

**WARNING**

**To ensure safe operation**

**Child Safety**

- Keep children indoors and supervised at all times any outdoor power grass/weed trimmer is being used nearby. Young children move quickly and are attracted especially to the grass/weed trimmer and trimming activity.
- Never assume children will remain where you last saw them. Be alert and turn the grass/weed trimmer off if children enter the area.
- Children should never be allowed to operate the grass/weed trimmer, even under adult supervision.

**Thrown Object Hazard**

Objects hit by the wheeling cutting attachment (nylon-line cutting head or cutting blade) can be thrown from the grass/weed trimmer with great force, and may cause serious injury.

- Thoroughly inspect the area where the grass/weed trimmer is to be used and remove all objects (stones, branches, wires, bones, etc...) which may be thrown by the wheeling cutting attachment.

**▲WARNING**

**To ensure safe operation**

**Operator Responsibility**

- Stop the engine and disconnect the spark plug cap in the following cases:
  - Before any operation around the cutting attachment (nylon-line cutting head or cutting blade).
  - Before checking, cleaning or working on the grass/weed trimmer.
  - After striking a foreign object. Inspect the grass/weed trimmer for damage and make repairs before restarting and operating the grass/weed trimmer again.
- If grass/weed trimmer starts to vibrate abnormally. Check immediately the cause of the vibration and perform the necessary repair.
- Stop the engine in the following cases:
  - Whenever you leave the grass/weed trimmer unattended.
  - Before refuelling.
  - When any person or pet is approaching.
  - Shut off the engine immediately when the grass/weed trimmer shows abnormal vibration suddenly. Sudden vibration can suggest the damaged rotating parts or loose fasteners. Examine the cause of the problem, and do not start the engine before repair is made.
  - When wires catch on the wheeling cutting attachment and flap around. Remove the wires after the cutting attachment has stopped turning.
  - Before placing the grass/weed trimmer on the ground, make sure the cutting attachment stops turning as well.
- Note that the cutting attachment is turning by inertia right after returning the throttle trigger and while the engine is idling.
- The grass/weed trimmer is faulty when the engine is idling by returning the throttle but the cutting attachment keeps turning, and idle speed adjustment must be made. Consult your authorized Honda dealer.
- Keep all nuts, bolts and screws tight to be sure the grass/weed trimmer is in safe working condition. Regular maintenance is an essential aid to user's safety and retaining a high level of performance.
- Do not use the grass/weed trimmer with worn or damaged parts. Parts must be replaced, or repaired. Replace worn or damaged parts with HONDA genuine parts. Non equivalent quality parts may damage the machine and be prejudicial to your safety.

**▲WARNING**

**To ensure safe operation**

**Operator Responsibility**

- Adjust the holding position of your grass/weed trimmer. Be sure to adjust the holding position with the engine stopped. Adjust the carrying harness so that the quick-release latch is positioned at your right hip. Hook the grass/weed trimmer to the carrying harness. Adjust the carrying harness length so that the cutting attachment is parallel to the ground and stays above the ground keeping the clearance specified below. Note that it might be hard to hold the grass/weed trimmer in the correct position if you are very tall. Do not operate the grass/weed trimmer if the cutting attachment is close to your feet when you hold the grass/weed trimmer at the correct position.
- Check the balance of the grass/weed trimmer between its front and rear sides for proper control and less fatigue. Hold the grass/weed trimmer at the correct position as described above. Slacken your grip on the handle gradually. Do not release but put your hands lightly on the handle and check that the cutting attachment-to-ground clearance does not change large this time. Balancing adjustment is necessary if the cutting attachment rises above your knees. Do not operate the grass/weed trimmer without the balancing adjustment.

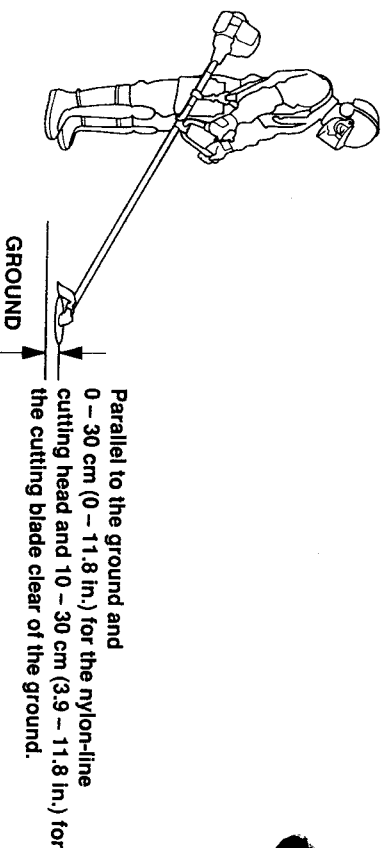

- Hold the grass/weed trimmer firmly with your both hands during operation to keep the trimmer under control at all times.

**To ensure safe operation**

**Operator Responsibility**

- \* **Safety boots**  
Wear the safety boots with the non-slip sole and toe protector to protect your feet from the flying debris.  
Do not operate the equipment when barefoot or wearing open sandals.
- \* Wear the leg protectors as well.
- \* Dust mask

We recommend that you wear the dust mask if you suffer from the allergic rhinitis, e.g. pollinosis, etc. The dust mask is available at a pharmacy and it is helpful for reducing the amount of pollens you breathe.

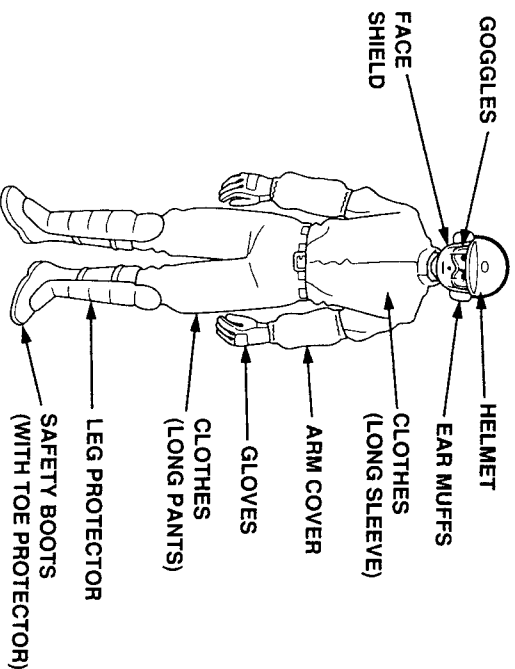

- Before each use, visually inspect the grass/weed trimmer including a cutting attachment for any damage and looseness of fastening part.
- Avoid operating the grass/weed trimmer at night or in a bad weather of poor visibility, because there is much possibility of accident.
- Walk, never run during operation.
- Avoid operating the grass/weed trimmer on a steep slope.  
The steep slope is very slippery, so you can slip down.

**To ensure safe operation**

**Operator Responsibility**

- Do not operate the grass/weed trimmer with the debris shield, labels, and other parts removed.  
Note that the debris shield is provided for protection of the operator from the debris that are thrown from the wheeling cutting attachment (nylon-line cutting head or cutting blade). Never operate the grass/weed trimmer with the debris shield removed or before installing the debris shield in the proper position securely.
- Do not mount an incorrect part and do not tamper with the grass/weed trimmer as it can result in personal injury and/or equipment damage. Use the cutting attachment that is designated for your model and application.
- Do not change the engine governor settings or overspeed the engine.
- Before cranking the engine, be sure to check the cutting attachment cannot come into contact with the ground or any obstruction.
- Start the engine carefully according to instructions and with hands and feet well away from the cutting attachment.
- Start the grass/weed trimmer on a level surface, free of high grass or obstacle.
- Do not raise the cutting attachment above your knee height during operation. You can be hit by the debris thrown by the wheeling cutting attachment in your eyes and face causing injury.
- Never carry the grass/weed trimmer while the cutting attachment is turning. Before you carry the grass/weed trimmer, be sure to stop the engine and confirm the cutting attachment stops its turning. If a cutting or saw blade is used, cover the blade with the protective plastic cover while carrying the trimmer.

**To ensure safe operation****Operator Responsibility**

- Any part from the machine is a potential source of danger if the machine is used in abnormal conditions or if the maintenance is not done correctly.
  - Read the owner's manual carefully. Be familiar with the controls and their proper use of the grass/weed trimmer. Know how to stop the engine rapidly, and how to unhook a harnesssed grass/weed trimmer quickly.
  - Use the grass/weed trimmer for the purpose it is intended for, that is trimming. Any other use could be dangerous or damage the grass/weed trimmer. Do not use the grass/weed trimmer as a pruning hook.
  - Never allow children or people unfamiliar with this owner's manual to use the grass/weed trimmer. Local regulations may restrict the age of the operator.
  - If you lend or resell your grass/weed trimmer to a third person, instruct him or her with how to handle the product and alert him or her to read the Owner's Manual carefully before operation.
  - Never operate the grass/weed trimmer while:
    - people, especially children or pets are nearby.
    - user is fatigued or under medication, or has swallowed substances known to affect judgement or reactions.
  - Keep people and pets at least 15 m (50 ft.) away from the operator during operation. Note that an assistant to the operator should work at least 15 m (50 ft.) away from the operator, too. We recommend to decide the engine stop signal and other signals between the operator and assistant, and use them for safety during operation.
- Keep in mind that the operator or user is responsible for accidents or hazards occurring to other people or their property.

**To ensure safe operation****Operator Responsibility**

- While operating the grass/weed trimmer, always wear following protective clothing and protective devices.
  - Protective clothing
    - Wear adequate clothes with long sleeves and long pants. The clothes must fit your body and button up or zip up the clothes securely. Do not leave the sleeves and bottom of the shirt/jacket loose. Wear the arm covers, too.
    - Do not wear the clothes with the tapes, laces and/or ribbons, loose clothes, necktie, necklace, etc. during operation. They can be caught in the grass/weed trimmer or on the weed causing injury. Bind your hair if it is long, and do not let your hair below your shoulder.
  - Protective devices
    - \* Goggles
      - Wear the goggles or other eye protection to protect your eyes from the debris that is thrown by the wheeling cutting attachment (nylon-line cutting head or cutting blade).
    - \* Helmet
      - Wear the helmet to protect your head from the overhead branches and the falling foreign material.
    - \* Face shield
      - Wear face shield to protect your face from the debris thrown by the wheeling cutting attachment.
    - \* Ear muffs/ear plugs
      - Wear the ear muff, ear plugs or other hearing protection to protect your ears from the noise.
    - \* Gloves
      - Wear the gloves to protect your hands.